

# MicroMouse™ & Water-Filled Mouse Phantoms and MicroCT Rods

Models 090, 091, 092



## ***PROVIDES STANDARD OF REFERENCE FOR MICRO-CT SCANNERS***

Micro-CT systems deliver precise, accurate and high-resolution measurements. The field of view of these systems requires appropriately scaled QA phantoms. The CIRS Model 090 MicroMouse™ and Model 091 Water-Filled Mouse Phantoms provide tools for quantifying calcium and bone density with respect to X-ray attenuation and absorption properties. Hydroxyapatite (HA), the principal constituent of teeth and bones within mammals, is the most appropriate reference for mineral density evaluations. CIRS blends HA in a soft-tissue equivalent, polymer background to provide references which can range in HA loading between 0 mg/cc and 750 mg/cc. Hydroxyapatite grain size and homogeneity of the rods are optimized for use in Micro-CT.

Both the solid MicroMouse Phantom and the Water-Filled Mouse phantom contain 11 rods of varying mineral loading and dimension. They can be used to evaluate Micro-CT scanners as you would standard whole body scanners. The targets are suitable for determining contrast detectability and estimating low-contrast resolution.

In the MicroMouse Phantom the rods are embedded in soft tissue equivalent epoxy material that is of the size and shape of a small rodent.

The Water-Filled Mouse Phantom contains the 11 rods in a water-tight, polycarbonate housing which is very durable and resistant to many chemicals. The Model 091 housing can easily be filled with a variety of liquids to vary the contrast between the rods and the surrounding liquid.

The 11 Micro-CT rods used in Model 090 and 091 are also available to purchase separately as the Model 092, along with other length, diameter, and HA loading options.

### ***Features***

- 25 mg/cc - 750 mg/cc HA targets
- Lung, Muscle and Adipose
- Optimal for Micro-CT
- Solid or Liquid Filled
- Individual rods in varying compositions and diameters

# SPECIFICATIONS

Model 090

<b>OVERALL DIMENSIONS:</b>	20 mm Ø x 60 mm
<b>ROD DIMENSIONS:</b>	
<b>RODS 1- 6</b>	2 mm Ø x 20 mm
<b>RODS 7-10</b>	4 mm Ø x 20 mm
<b>ROD 11</b>	5 mm Ø x 10 mm
<b>MATERIAL:</b>	Tissue-Equivalent Epoxy

<b>COMPONENT:</b>	<b>COMPOSITION:</b>
Body	Muscle
Rod 1	0 mg/cc
Rod 2	50 mg/cc
Rod 3	100 mg/cc
Rod 4	250 mg/cc
Rod 5	500 mg/cc
Rod 6	750 mg/cc
Rod 7	0 mg/cc
Rod 8	50 mg/cc
Rod 9	250 mg/cc
Rod 10	750 mg/cc
Rod 11	Lung (Low density, inhale)

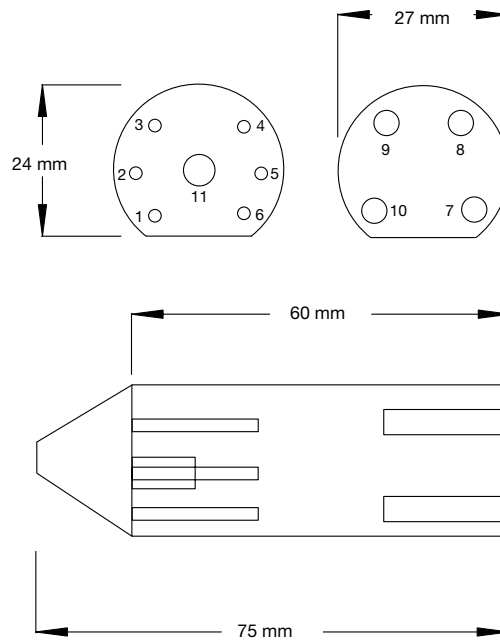

# SPECIFICATIONS

Model 091

<b>OVERALL DIMENSIONS:</b>	30 mm Ø x 82 mm
<b>ROD DIMENSIONS:</b>	
<b>RODS 1-4, 9, 11</b>	4 mm Ø x 30 mm
<b>RODS 5-8</b>	2 mm Ø x 30 mm
<b>ROD 10</b>	5 mm Ø x 30 mm
<b>MATERIAL:</b>	
<b>HOUSING:</b>	Polycarbonate
<b>RODS:</b>	Tissue-Equivalent Epoxy

<b>COMPONENT:</b>	<b>COMPOSITION:</b>
Body	Water
Rod 1 & 5	0 mg/cc
Rod 2 & 6	50 mg/cc
Rod 3 & 7	250 mg/cc
Rod 4 & 8	750 mg/cc
Rod 9	Adipose
Rod 10	Lung
Rod 11	Muscle

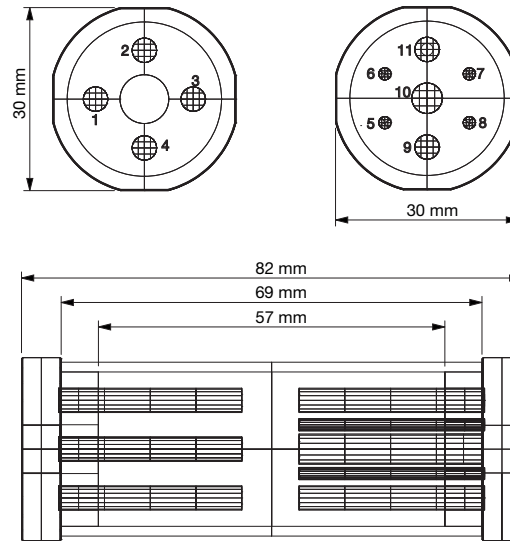

# SPECIFICATIONS

Model 092

## CONFIGURATION OPTIONS

Micro-CT Rods are available for individual purchase. Rod options vary in diameter and HA loading and come in 20 mm and 50 mm lengths. When ordering, please refer to the table of configuration options below, where XX is either 20 for 20 mm length or 50 for 50 mm length. All rods are made of a tissue-equivalent epoxy.

	0 MG/CC	25 MG/CC	50 MG/CC	100 MG/CC	250 MG/CC	500 MG/CC	750 MG/CC
<b>2MM</b>	092-XX-02-000	092-XX-02-025	092-XX-02-050	092-XX-02-100	092-XX-02-250	092-XX-02-500	092-XX-02-750
<b>4MM</b>	092-XX-04-000	092-XX-04-025	092-XX-04-050	092-XX-04-100	092-XX-04-250	092-XX-04-500	092-XX-04-750
<b>5MM</b>	092-XX-05-000	092-XX-05-025	092-XX-05-050	092-XX-05-100	092-XX-05-250	092-XX-05-500	092-XX-05-750
<b>8MM</b>	092-XX-08-000	092-XX-08-025	092-XX-08-050	092-XX-08-100	092-XX-08-250	092-XX-08-500	092-XX-08-750
<b>16MM</b>	092-XX-16-000	092-XX-16-025	092-XX-16-050	092-XX-16-100	092-XX-16-250	092-XX-16-500	092-XX-16-750
<b>32MM</b>	092-XX-32-000	092-XX-32-025	092-XX-32-050	092-XX-32-100	092-XX-32-250	092-XX-32-500	092-XX-32-750

