



HC1A-FGE/HGE



HC1A-FGE/HGE
10/16/25
Item # 13746

One Section Heated Cabinet
Full and Half Glass Doors

W x D x H

27.5" x 33.5" x 79.5"*

*with 4" casters

Item #: _____

Project: _____

Qty: _____

AIA#: _____

HC1A-FGE



HC1A-HGE



Features

- ▶ Interior top-mounted heating element with fan to circulate heat through cabinet; heat shield foamed in next to heating element
- ▶ Additional storage fits 12 sheet pans
- ▶ Maximum interior storage capacity with smallest external footprint
- Glass doors are energy efficient multi-pane, argon-filled with locks
- Stainless steel interior with stainless exterior front, sides, and top
- Energy efficient interior LED light
- Solid state digital controller with temperature alarms and LED display (Fahrenheit or Celsius)
- Cabinet and doors are insulated with 2-3/8" of CFC free, foamed in place polyurethane
- Glass doors have magnetic snap-in gasket
- Self-closing doors with stay open feature
- One piece, full length handle
- Sturdy 8 gauge stainless steel hinge plate with welded hinge pin
- Field reversible doors
- Door locks are standard
- Stainless steel shelf supports
- (3) epoxy coated wire shelves are standard
- A single section cabin can hold between 20-24 tray slides depending on the product
- Standard with 4" casters (two with brakes)
- 10 ft. cord and plug



Dimensions / Capacity

One Section

HC1A-FGE HC1A-HGE

Interior Storage Capacity (CF) (AHAM)	22.70 ft ³	22.62 ft ³
Overall Width x Depth	27.5" x 33.5"	27.5" x 33.5"
Height (including 4" casters)	79.5"	79.5"
Door Opening Width x Height	21.75" x 59.25"	21.75" x 27.75"
Depth with Door Open at 90°	59.25"	59.25"
Adjustable Shelves	3	3
Shelf Dimensions (W x D)	21.25" x 26"	21.25" x 26"
Crated Shipping Weight	340 lbs	340 lbs
Crated Length x Depth x Height	37.5" x 31.5" x 81"	37.5" x 31.5" x 81"

Electrical / Refrigeration

One Section HC1A-FGE/HC1A-HGE

Voltage	115/60/1
HACR Breaker	15.0 Amps
Electrical Connection (NEMA)	5-15P
Voltage Range	104-126
Ambient Temp. Range	45° to 100°F
Control Setpoint Range	140°-180°F
Amperage	10
Energy Consumption (w) @ASTM 2140-11	175.5

Options

- Additional epoxy shelves
- Stainless steel shelves
- 2 Pan slides (HS-3557)
- 8 Pan Slides (HS-3558)
- Foot pedal (Rt. Hinge HS-5379)
- 1 Wire slide (HS-5092)
- 4 Wire slides (HS-5093)
- 6" Adjustable legs



Seven year warranty on labor, parts, and compressor. Valid in United States, Canada, Puerto Rico and U.S. Territories.

If GFCI is required, a GFCI breaker MUST be used in lieu of GFCI receptacle



HC1A-FGE/HGE



HC1A-FGE/HGE
10/16/25
Item # 13746

One Section Heated Cabinet Full and Half Glass Doors

FRONT VIEW

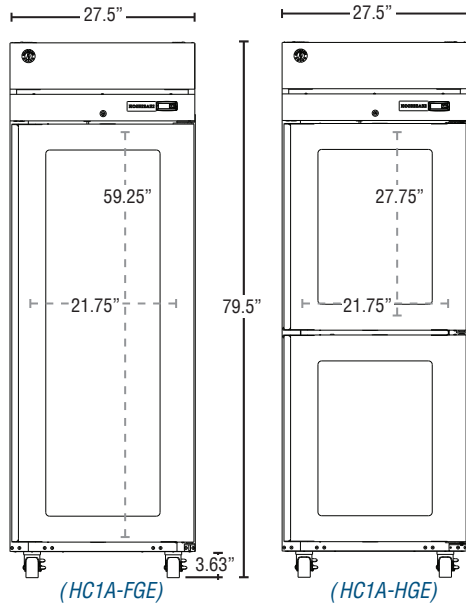

SIDE VIEW

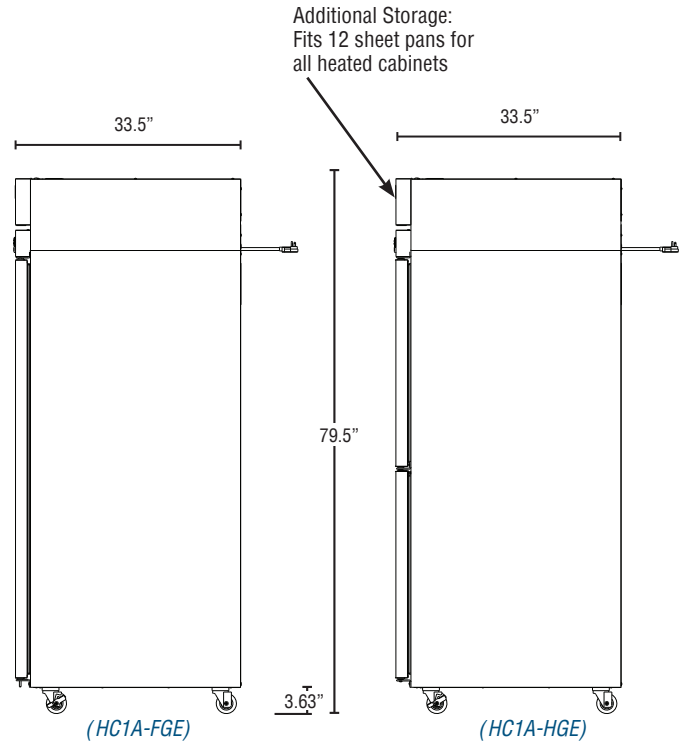

Note: 0" Minimum clearance requirement on side, top and rear.

PLAN VIEW

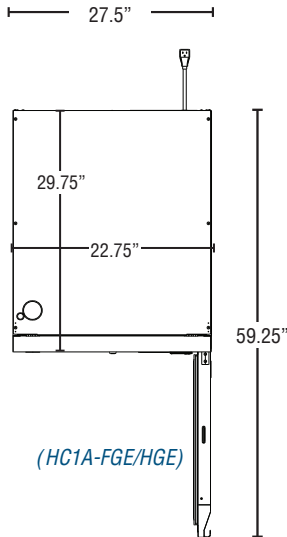

Cabinet Construction

The exterior cabinet front, sides, and top are constructed of high quality stainless steel. The exterior back, and bottom are constructed of coated steel. The cabinet interior is constructed of stainless steel with a unique ducted air flow system. Three (3) heavy duty epoxy coated shelves per section are standard. Mounted on stainless steel pilasters shelves are adjustable in 1" increments. Cabinet walls and doors are insulated with 2-3/8" of environmentally friendly, CFC free, foamed in place polyurethane. 4" polyolefin, casters (two with brakes) are standard.

Door Construction

Glass doors are constructed of a high grade stainless steel exterior and interior and come standard with locks. Door glass is energy efficient multi pane, argon filled. The door hinges are all metal and include an adjustable torsion spring closure that will not wear out like traditional cam-lift hinges. Hinge plates are constructed of heavy duty stainless steel. Doors stay open at 90° and are self-closing at 75°. Snap-in magnetic door gaskets are durable and easily removed for cleaning. Door hinging is field reversible.

Operating System

The heating system consists of a high temperature fan which pulls air from the cabinet space and blows it across a resistive heater. From there, the air passes through a duct, which disperses the air equally across the height and depth of the cabinet through a carefully engineered louver pattern. A built-in ceramic heat shield adjacent to the heating element protects the blown foam insulation from contracting in the locally hot temperatures, maintaining the cabinet's structural integrity. A 6000 K LED lighting system illuminates the interior of the cabinet when selected. Specialty high-temperature rated gaskets are recessed from the interior of the door, protecting them. Solid state digital controls monitor the operation and maintain proper temperature of the cabinet space. The controls provide visual high and low temperature and high and low voltage alarms. The LED display shows the cabinet temperature and is adjustable to Fahrenheit or Celsius. The 1-sections are 115 volts and the 2 sections are 208/230 volts.