



HOSHIZAKI

Instruction Manual

Steelheart Series
Heated Kitchen Equipment

Models
Holding Cabinet A

Issued: 6-30-2025
Revised: 12-18-2025

⚠ WARNING

Only qualified service technicians should install and service the appliance. To obtain the name and phone number of your local Hoshizaki Certified Service Representative, visit www.hoshizakiamerica.com. No installation or service should be undertaken until the technician has thoroughly read this Instruction Manual. Likewise, the owner/manager should not proceed to operate the appliance until the installer has instructed them on its proper operation. Failure to install, operate, and maintain the appliance in accordance with this manual may adversely affect safety, performance, component life, and warranty coverage. Proper installation is the responsibility of the installer. Product failure or property damage due to improper installation is not covered under warranty.

Hoshizaki provides this manual primarily to assist qualified service technicians in the installation, maintenance, and service of the appliance.

Should the reader have any questions or concerns which have not been satisfactorily addressed, please call, send an e-mail message, or write to the Hoshizaki Technical Support Department for assistance.

Phone: 1-800-233-1940; (770) 487-2331

E-mail: tech-support@hoshizaki.com

HOSHIZAKI AMERICA, INC.

618 Highway 74 South
Peachtree City, GA 30269
Attn: Hoshizaki Technical Support Department

NOTE: To expedite assistance, all correspondence/communication **MUST** include the following information:

- Model Number _____
- Serial Number _____
- Complete and detailed explanation of the problem.

IMPORTANT

This manual should be read carefully before the appliance is installed and operated. Read the warnings and guidelines contained in this booklet carefully as they provide essential information for the continued safe use and maintenance of the appliance. Retain this booklet for any further reference that may be necessary.

CONTENTS

Important Safety Information	4
I. Specifications.....	7
A. Electrical Data	7
1. Solid Doors.....	7
2. Glass Doors.....	7
II. Installation Instructions	8
A. Location	8
B. Checks Before Installation.....	9
C. Setup.....	10
D. Food Cart Ramp (Roll-In/Roll-Thru Appliances).....	11
E. Door Reversal	13
1. Full Door Reversal (Solid or Glass)	13
2. Half Door Reversal (Solid or Glass).....	16
F. Electrical Connection	21
G. Final Checklist	22
III. Operating Instructions.....	23
A. Important Notes About Usage	23
B. Startup	25
C. Controls and Adjustments	25
D. Control Module Icons	27
E. Food Storage.....	28
F. Alarm Safeties	29
G. Heating Performance.....	30
IV. Cleaning and Maintenance Instructions.....	31
A. Cleaning	31
B. Maintenance.....	32
V. Preparing the Appliance for Periods of Non-Use	33
VI. Disposal.....	34

Important Safety Information

Throughout this manual, notices appear to bring your attention to situations which could result in death, serious injury, damage to the appliance, or damage to property.

⚠ DANGER	Indicates a hazardous situation that, if not avoided, will result in death or serious injury.
⚠ WARNING	Indicates a hazardous situation that, if not avoided, could result in death or serious injury.
NOTICE	Indicates a situation that, if not avoided, could result in damage to the appliance or property.
IMPORTANT	Indicates important information about the use and care of the appliance.

⚠ DANGER	⚠ DANGER
<ul style="list-style-type: none"> • Follow handling instructions carefully in compliance with U.S. government regulations. • Component parts shall be replaced with like components. • Consult instruction manual/service manual before attempting to install or service this product. All safety precautions must be followed. • Dispose of properly in accordance with federal or local regulations. 	<p><u>Risque De Feu Ou D'Explosion</u></p> <p><u>Le Frigorigène Est Inflammable</u></p> <ul style="list-style-type: none"> • Suivre attentivement les instructions de manipulation conformément à la réglementation gouvernementale. • Les pièces des composants doivent être remplacées par des pièces et accessoires équivalents. • Consulter le manuel du propriétaire/ guide de réparation avant de tenter une réparation. Toutes les mesures de sécurité doivent être respectées. • Éliminer conformément aux règlements fédéraux ou locaux.

⚠ WARNING

The appliance should be destined only to the use for which it has been expressly conceived. Any other use should be considered improper and therefore dangerous. The manufacturer cannot be held responsible for injury or damage resulting from improper, incorrect, and unreasonable use. Failure to install, operate, and maintain the appliance in accordance with this manual will adversely affect safety, performance, component life, and warranty coverage.

To reduce the risk of death, electric shock, serious injury, or fire, follow basic precautions including the following:

- Only qualified service technicians should install and service the appliance.
- Wear appropriate personal protective equipment (PPE) when servicing the appliance.
- The appliance must be installed in accordance with applicable national, state, and local codes and regulations.
- Appliance is heavy. Use care when lifting or positioning. Work in pairs when needed to prevent injury or damage.
- To reduce the risk of electric shock, do not touch the plug with damp hands.
- Unplug the appliance before servicing.
- The appliance requires an independent power supply of proper capacity. See the nameplate for electrical specifications. Failure to use an independent power supply of proper capacity can result in a tripped breaker, blown fuse, damage to existing wiring, or component failure. This could lead to heat generation or fire.

⚠ WARNING, continued

• **115VAC Models: THIS APPLIANCE**

MUST BE GROUNDED: This appliance is equipped with a NEMA 115VAC 5-15 three-prong grounding plug  to reduce the risk of potential shock hazards.

It must be plugged into a properly grounded, independent 3-prong wall outlet. If the outlet is a 2-prong outlet, it is your personal responsibility to have a qualified electrician replace it with a properly grounded, independent 3-prong wall outlet. Do not remove the ground prong from the plug and do not use an adapter plug. Failure to follow these instructions may result in death, electric shock, or fire.

• **208/230VAC Models: THIS APPLIANCE**

MUST BE GROUNDED: This appliance is equipped with a NEMA 208-230 L14-20 four-prong locking, grounding plug  to reduce the risk of potential shock hazards. It must be plugged into a properly grounded, independent 4-prong locking wall outlet. If the outlet is a 3-prong outlet or a 4-prong non-locking outlet, it is your personal responsibility to have a qualified electrician replace it with a properly grounded, independent 4-prong locking wall outlet. Do not remove the ground prong from the plug and do not use an adapter plug. After plugging in, twist the plug clockwise to lock it into place. Failure to follow these instructions may result in death, electric shock, or fire.

- Do not use an extension cord.
- Do not use an appliance with a damaged power cord. The power cord should not be altered, jerked, bundled, weighed down, pinched, or tangled. Such actions could result in electric shock or fire. To unplug the appliance, be sure to pull the plug, not the cord, and do not jerk the cord.

⚠ WARNING, continued

- The GREEN ground wire in the factory-installed power cord is connected to the appliance. If it becomes necessary to remove or replace the power cord, be sure to connect the power cord's ground wire.
- Do not splash, pour, or spray water directly onto or into the appliance. This might cause short circuit, electric shock, corrosion, or failure.
- Do not make any alterations to the appliance. Alterations could result in electric shock, injury, fire, or damage to the appliance.
- The appliance is not intended for use by persons (including children) with reduced physical, sensory, or mental capabilities, or lack of experience and knowledge, unless they have been given supervision or instruction concerning use of the appliance by a person responsible for their safety.
- Children should be properly supervised around the appliance.
- Do not climb, stand, or hang on the appliance or doors or allow children or animals to do so. Do not climb into the appliance or allow children or animals to do so. Death or serious injury could occur or the appliance could be damaged.
- Be careful not to pinch fingers when opening and closing the doors or when handling food pans. Be careful when opening and closing the doors when children are in the area.
- Open and close the doors with care. Opening the doors too quickly or forcefully may cause injury or damage to the appliance or surrounding equipment.
- Do not use combustible spray or place volatile or flammable substances in or near the appliance. They might catch fire.
- Do not place any product on the floor of the cabinet. All product must be placed on properly installed shelves.

⚠ WARNING, continued

- Do not block air inlets or outlets, otherwise heating performance may be reduced.
- Do not tightly pack the cabinet. Allow some space between items to ensure good air flow. Also allow space between items and interior surfaces.
- Food storage and handling must comply with applicable codes and regulations.
- Do not store items near air outlets. Otherwise, items may scorch and crack or break causing a risk of injury or contamination of other food.
- Keep the area around the appliance clean. Dirt, dust, or insects in the appliance could cause harm to individuals or damage to the equipment.
- Do not throw anything onto the shelves or load any single shelf with more than 120 lb. (54.5 kg) of product. They might fall off and cause injury.
- This appliance is designed for holding heated prepared foods at a safe temperature. Use for any other purposes could cause contamination and deterioration of stored items.

NOTICE

- Protect the floor when moving the appliance to prevent damage to the floor.
- Keep ventilation openings clear of obstruction.
- Care should be used when placing items on top of the appliance. Foreign objects or moisture could enter the appliance and result in electric shock or fire.
- To prevent deformation or cracks, do not spray insecticide onto the plastic parts or let them come into contact with oil.
- To avoid damage to the gasket, use only the door handle when opening and closing.

I. Specifications

A. Electrical Data

The nameplate provides electrical and refrigerant data. The nameplate is located on the upper part of the left side panel. For certification marks, see the nameplate.

We reserve the right to make changes in specifications and design without prior notice.

1. Solid Doors

MODEL NUMBER	HC1A-FS(-HS)	HC1A-FS-FS(-HS-HS)
AC SUPPLY VOLTAGE	115/60/1	115/60/1
AMPERES	10.0 AMPS	10.0 AMPS
MAX. HACR BREAKER	15	15
EQUIPPED WITH PLUG	NEMA 5-15	NEMA 5-15

Model Number	HCRN1A-FS	HCRT1A-FS-FS
AC SUPPLY VOLTAGE	115/60/1	115/60/1
AMPERES	11.0 AMPS	11.0 AMPS
MAX. HACR BREAKER	15	15
EQUIPPED WITH PLUG	NEMA 5-15	NEMA 5-15

Model Number	HC2A-FS(-HS)	HC2A-FS-FS(-HS-HS)
AC SUPPLY VOLTAGE	208-230/60/1	208-230/60/1
AMPERES	9.0/10.0 AMPS	9.0/10.0 AMPS
MAX. HACR BREAKER	20	20
EQUIPPED WITH PLUG	NEMA L14-20	NEMA L14-20

Model Number	HCRN2A-FS	HCRT2A-FS-FS
AC SUPPLY VOLTAGE	208-230/60/1	208-230/60/1
AMPERES	10.0/11.0 AMPS	10.0/11.0 AMPS
MAX. HACR BREAKER	20	20
EQUIPPED WITH PLUG	NEMA L14-20	NEMA L14-20

2. Glass Doors

Model Number	HC1A-FGE(-HGE)	HC1A-FGE-FGE(-HGE-HGE)
AC SUPPLY VOLTAGE	115/60/1	115/60/1
AMPERES	10.0 AMPS	10.0 AMPS
MAX. HACR BREAKER	15	15
EQUIPPED WITH PLUG	NEMA 5-15	NEMA 5-15

Model Number	HC2A-FGE(-HGE)	HC2A-FGE-FGE(-HGE-HGE)
AC SUPPLY VOLTAGE	208-230/60/1	208-230/60/1
AMPERES	9.0/10.0 AMPS	9.0/10.0 AMPS
MAX. HACR BREAKER	20	20
EQUIPPED WITH PLUG	NEMA L14-20	NEMA L14-20

II. Installation Instructions

WARNING

- This appliance must be installed in accordance with all applicable national, state, and local regulations.
- Appliance is heavy. Use care when lifting or positioning. Work in pairs when needed to prevent injury or damage.
- Do not tilt the appliance more than 45°.

A. Location

WARNING

- This appliance is not intended for outdoor use.
- Normal operating ambient temperature:
 - Heated Holding Cabinet 45°F to 104°F (7°C to 40°C)Operation of the appliance, for extended periods, outside of this normal temperature range may affect appliance performance.

For best operating results:

- The location should provide a firm and level foundation for the appliance.
- The appliance should not be located in a corrosive environment.
- Minimum Clearance:

Models	Side	Top	Rear
All Heated Holding Cabinets	0" (0 cm)	0" (0 cm)	0" (0 cm)
Pass-Thru's	0" (0 cm)	0" (0 cm)	N/A

B. Checks Before Installation

⚠ WARNING

Refer to the nameplate for electrical specifications. See Fig. 1. The nameplate is located on the front right side of the top panel. For more electrical connection details, see "I.F. Electrical Connection." We reserve the right to make specification and design changes without prior notice.

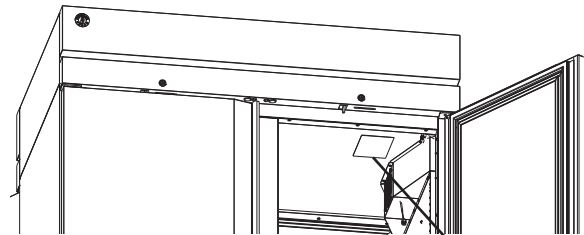

Model Shown: HC2A-FS-FS(-HS-HS)

Nameplate

Fig. 1

- Visually inspect the exterior of the shipping package and immediately report any damage to the carrier. Upon opening the package, any concealed damage should also be immediately reported to the carrier.
- Remove the shipping carton, tape, and packing material. Remove the protective plastic film from the exterior panels on all models. If the appliance is exposed to the sun or to heat, remove the film after the appliance cools.
- Remove all accessory containers before discarding the packing materials. Dispose of all packing materials in a proper and environmentally responsible manner.
- Check for missing or damaged accessories.

C. Setup

1. Caster or Optional 6 in. Leg Installation and Leveling the Appliance

a) Caster or Optional 6 in. Leg Installation

- 1) Move as close to the final location as possible.
- 2) Remove the 2 bolts securing the appliance to the pallet, then remove the appliance from the pallet. Block the appliance securely at a height of 8 in. (20 cm) off the floor. Do not lay the appliance down. **NOTICE! Do not allow the door(s) to bear the weight of the appliance.**

- a) Casters: Attach and tighten the casters to the bottom of the appliance. Locking casters should be attached to the front of the appliance for standard models and on the service (control module) side on pass-thru models. See Fig. 2.

NOTICE! Ensure casters are completely threaded into appliance and tight.

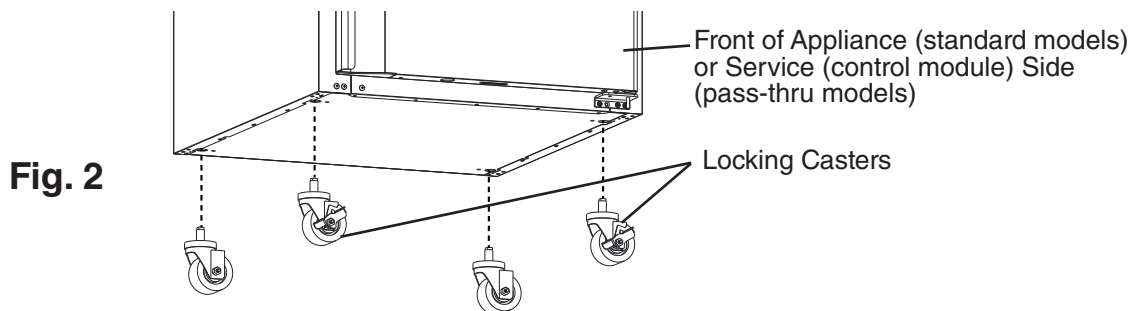

- b) Legs: Optional 6 in. legs available. Attach and tighten the optional adjustable 6 in. legs to the bottom of the appliance.

⚠ WARNING

When using legs, avoid sliding the appliance across the floor after legs are installed.

b) Leveling the Appliance

After installing the casters or optional 6 in. legs, lower the appliance to the floor and check the level of the appliance.

- a) Casters: If the appliance is out of level, follow the instructions and steps found in HS-3590 provided in the accessories bag. Otherwise, continue to the next section. **NOTICE! Make sure the casters are tight and no gap is left between the casters, shim plates, and appliance.**
- b) Legs: If the appliance is out of level, turn the bottom portion of the leg for height adjustment. Otherwise, continue to the next section. **NOTICE! Make sure the legs are tight and no gap is left between the leg and appliance.**

2. Install the Shelves

Shelf support clips are provided in the accessory pack.

- 1) Place the shelf support clips into the pilasters (4 shelf support clips per shelf). Indexing holes are provided on the pilasters in evenly spaced intervals to assist in positioning the support clips at the same height. See Fig. 3.
- 2) Place the shelves in position on the shelf support clips.

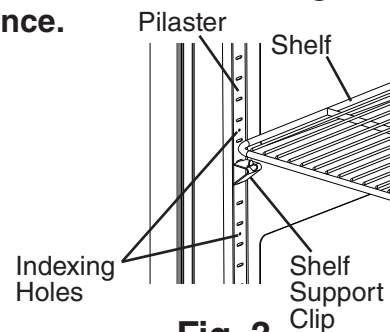

Fig. 3

D. Food Cart Ramp (Roll-In/Roll-Thru Appliances)

Confirm the area where the appliance is to be installed is flat and level.

- 1) Place the appliance in position, then seal the perimeter where the appliance contacts the floor with approved caulk compound in a smooth and easily cleanable manner.

See Fig. 4.

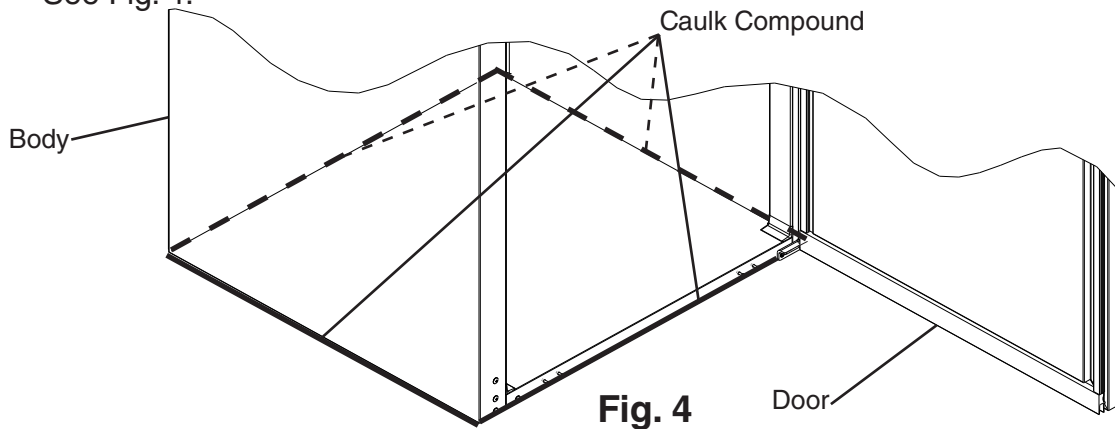

Fig. 4

- 2) Remove the 2 filler screws from the bottom of the appliance. See Fig. 10. Next, loosen the 4 truss head screws at the bottom of the appliance 3 to 4 mm (1/8"), then lay the ramp onto the loosened truss head screws. See Fig. 5.

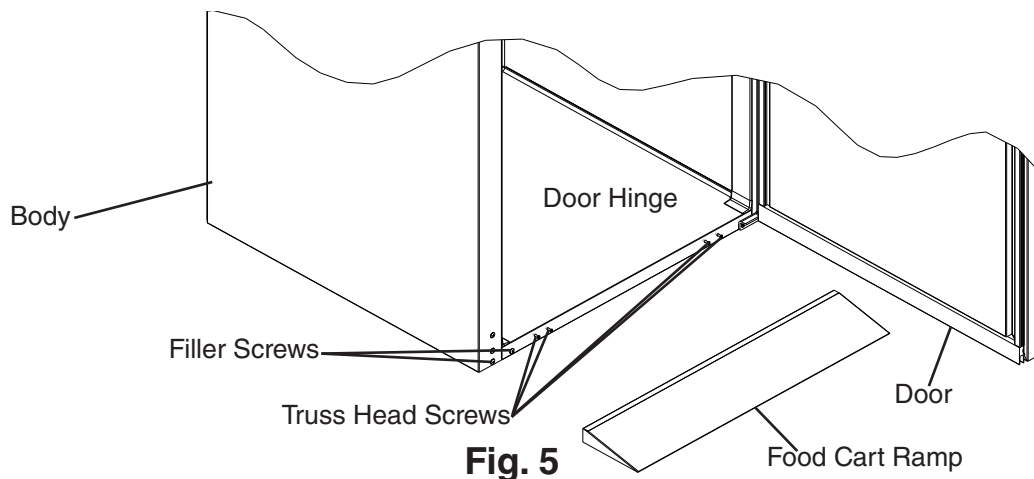

Fig. 5

- 3) Seal around the ramp as shown in Fig. 6 with an approved caulk compound.

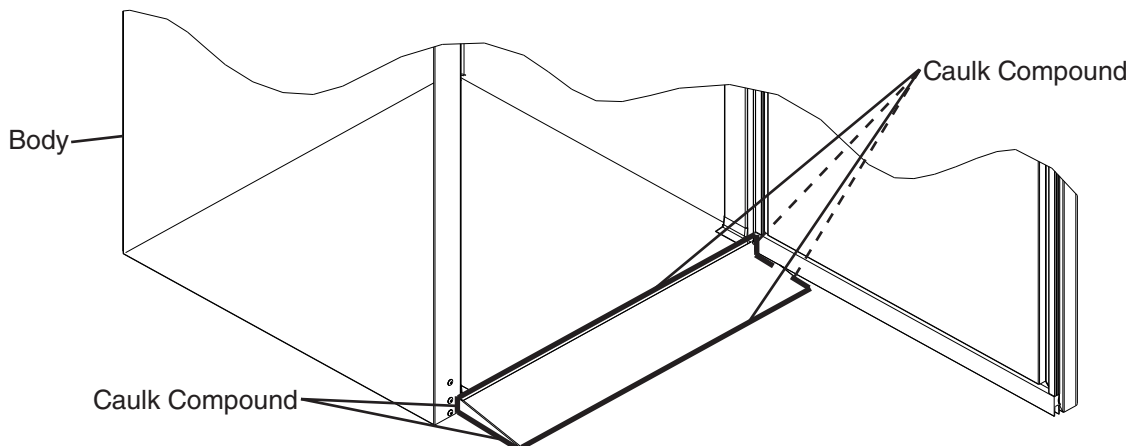

Fig. 6

4) Loosen the door sweep bracket adjustment screws. See Fig. 7.

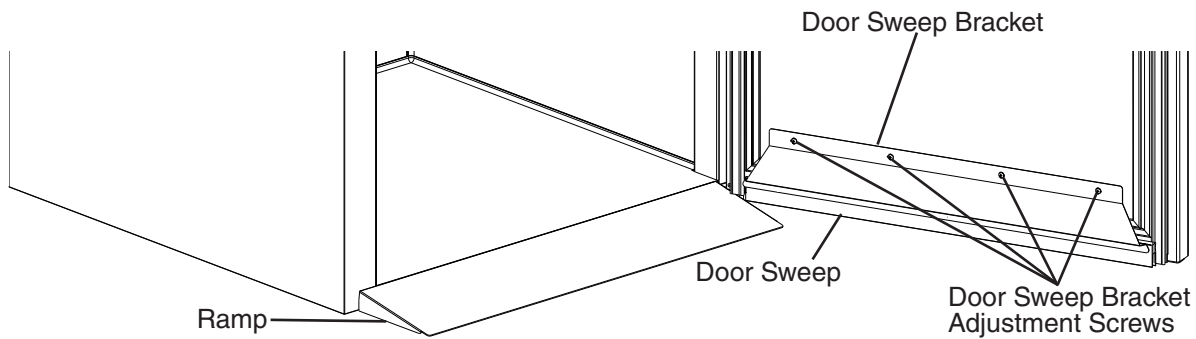

Fig. 7

5) Adjust the door sweep so that the door sweep touches the ramp when the door is closed. See Fig. 8. Once in its correct position, tighten the door sweep bracket adjustment screws.

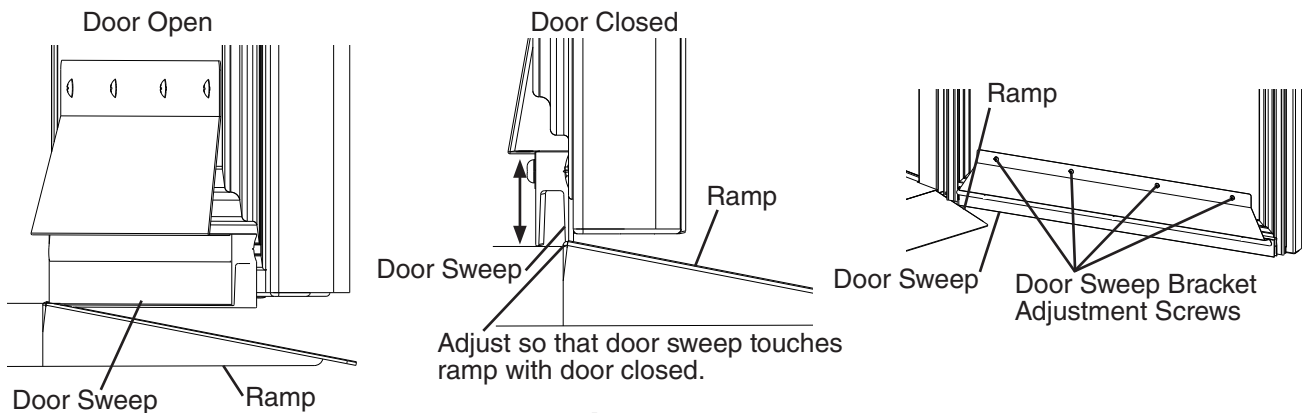

Fig. 8

6) Drill three 1/8" pilot holes in the positions shown in Fig. 9. Use the 3 screws provided in the accessory bag to secure the door sweep to the door sweep bracket and the door. Confirm the area where the appliance is to be installed is flat and level.

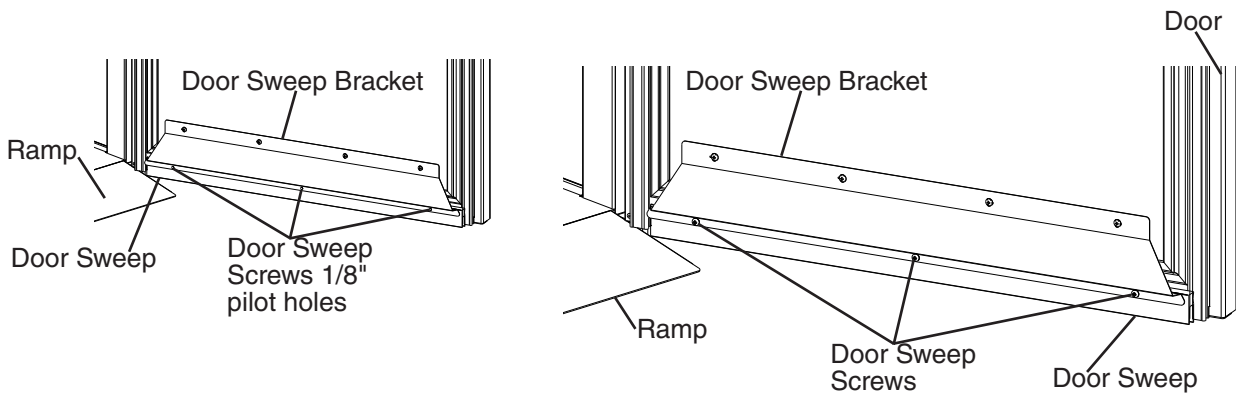

Fig. 9

E. Door Reversal

This appliance is provided with a cabinet design which, after being delivered to the installation location, permits changing of the door swing from left to right or right to left.

⚠ WARNING

- Wear proper PPE (personal protection equipment) when executing these procedures (safety glasses and gloves).
- Keep fingers away from edge of upper hinge bracket. Spring cartridge can cause the upper hinge bracket to move suddenly with extreme force.

1. Full Door Reversal (Solid or Glass)

Note: Hinge brackets and spring cartridge are universal and can be used in both left and right-hinged applications.

Example shows change from right-hinged to left-hinged.

- 1) Lock the casters.
- 2) Raise the front panel, then remove the control panel screws. Next, lift the control panel up and lift off of the control panel collars. Be careful not to pull the wires on the control module and door switch(es), remove the control panel and place in the holding area above the control panel. See Fig. 10.

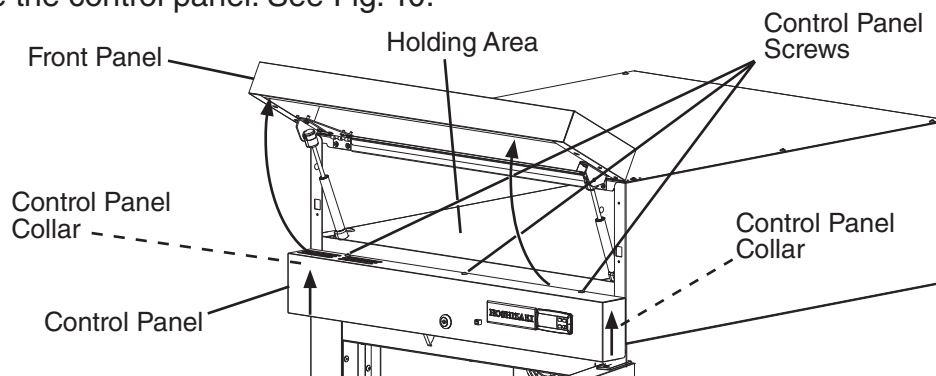

Fig. 10

- 3) While maintaining a hold on the door, remove the upper hinge bracket, then lift the door up off the bottom hinge and set aside. See Fig. 11. Remove the filler screws from the opposite side upper hinge bracket holes and mount them into the holes of the removed upper hinge bracket. **NOTICE! Be sure to reuse the bracket screws for mounting the bracket as the bracket screws are 5×12 and filler screws are 5×10.**

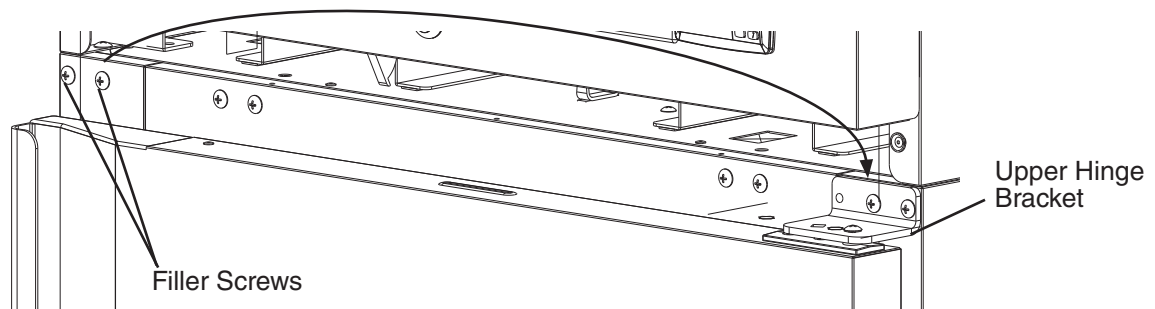
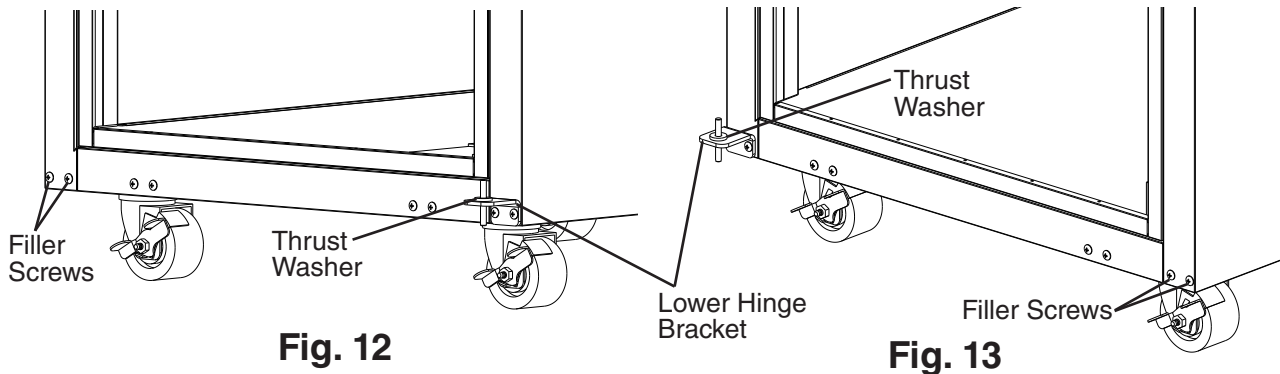
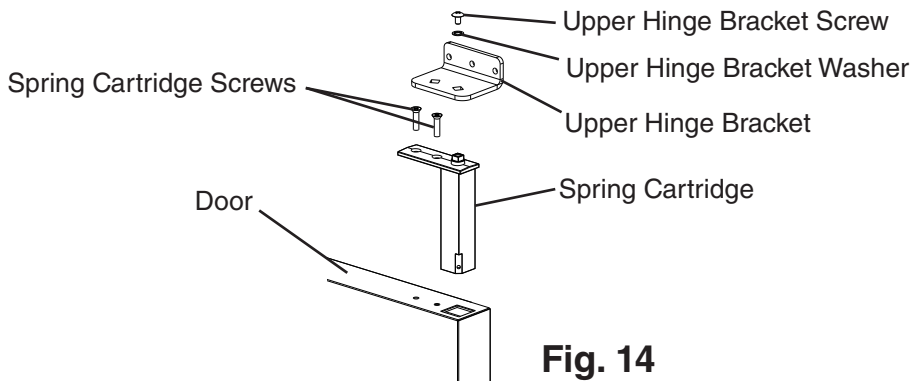

Fig. 11

- 4) Remove the lower hinge bracket and thrust washer. See Fig. 12. Retain thrust washer for opposite side lower hinge bracket installation. Remove the filler screws from the opposite side lower hinge bracket holes and mount them into the holes of the removed lower hinge bracket. **NOTICE! Be sure to reuse the bracket screws for mounting the bracket as the bracket screws are 5x12 and filler screws are 5x10.**
- 5) Secure the lower hinge bracket to the opposite side lower hinge bracket location, then place the thrust washer on the lower hinge bracket. See Fig. 13.



- 6) Remove the screw and washer securing the upper hinge bracket to the spring cartridge. Remove the 2 screws securing the spring cartridge to the door, then remove the spring cartridge from the door. See Fig. 14.



- 7) Rotate the door 180 degrees, to its new orientation. Remove the nylon bearing and filler screws. See Fig. 15. **NOTICE! Care should be taken not to damage the door.** Mount the nylon bearing and filler screws into the holes left by the spring cartridge in the lower section of the door. See Fig. 16.

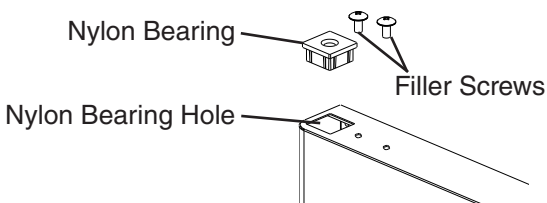

Fig. 15

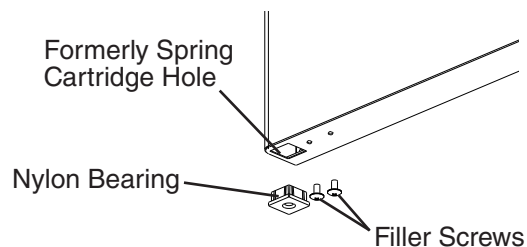
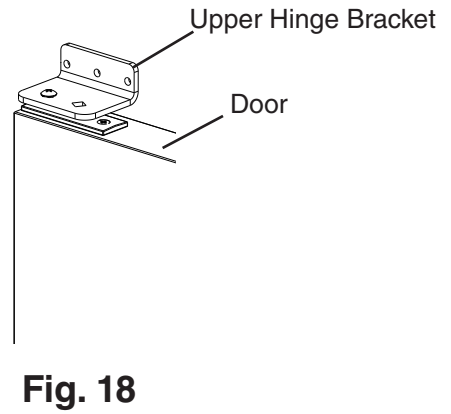
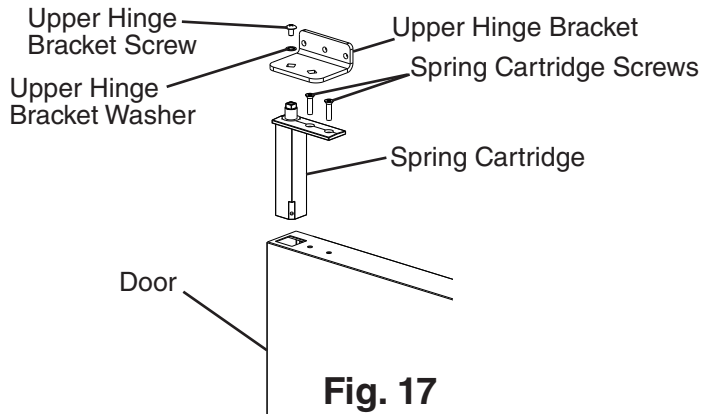

Fig. 16

8) Clear foam from the spring cartridge hole to allow for spring cartridge installation. Install the spring cartridge and secure it to the door using the spring cartridge screws removed in step 6. See Fig. 17. Next, align the upper hinge bracket to the door in the orientation that allows for closed door installation. See Fig. 18. Secure the upper hinge bracket to the door using the screw and washer removed in step 6.



9) Make sure the thrust washer is in place, then mount the door onto the lower hinge bracket (nylon bearing over lower hinge bracket pin). See Fig. 19.

10) Secure the upper hinge bracket to the appliance. See Fig. 20.

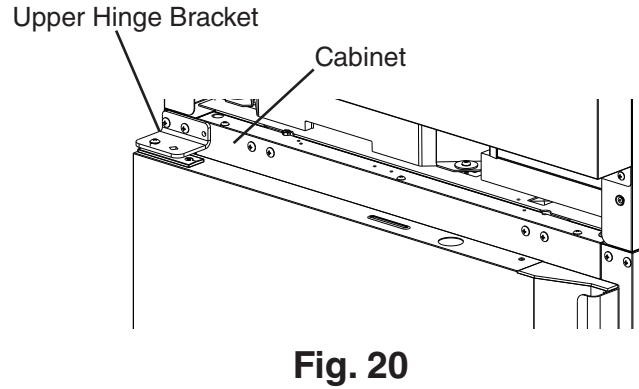
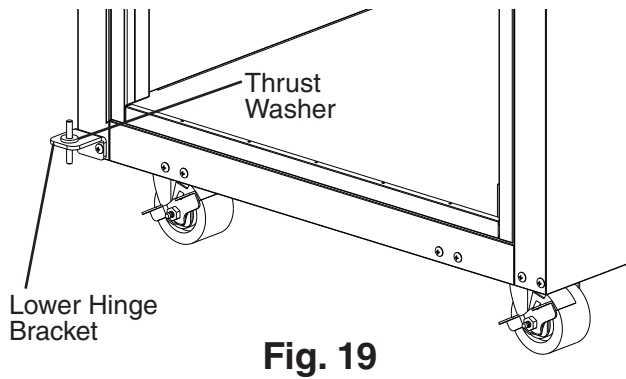

11) Verify the door swing. Move the control panel hole plugs to the other side, then replace and secure the control panel and front panel in their correct positions. Verify the door switch and lock function.

2. Half Door Reversal (Solid or Glass)

Note: Hinge brackets and spring cartridge are universal and can be used in both left and right-hinged applications.

Example shows change from right-hinged to left-hinged.

- 1) Lock the casters.
- 2) Raise the front panel, then remove the control panel screws. Next, lift the control panel up and lift off of the control panel collars. Be careful not to pull the wires on the control module and door switch(es), remove the control panel and place in the holding area above the control panel. See Fig. 21.

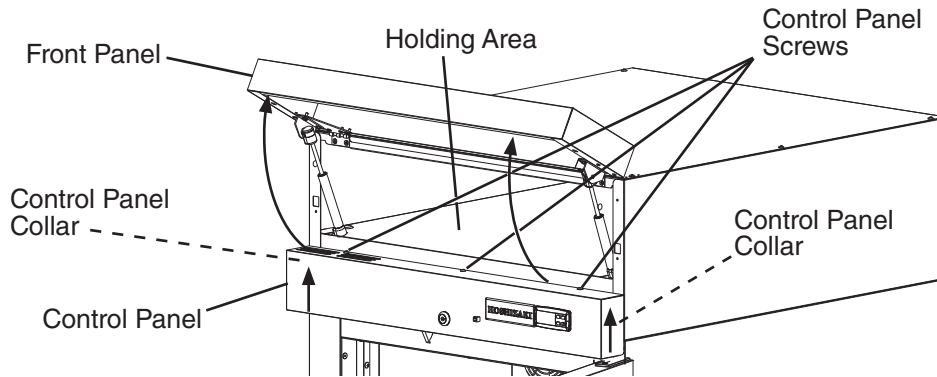

Fig. 21

- 3) While maintaining a hold on the upper door, remove the upper hinge bracket then lift the door off the center hinge bracket. See Fig. 22. Retain the upper center hinge bracket thrust washer for opposite side hinge bracket installation.

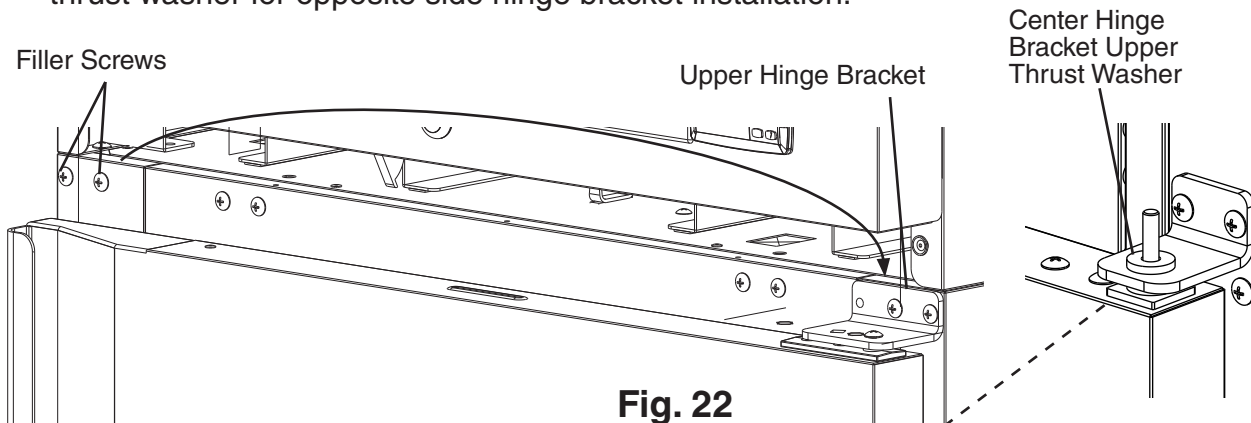

Fig. 22

- 4) Rotate the upper hinge bracket 180 degrees counter clockwise. See Fig. 23. Next, remove the spring cartridge screw and washer, then remove the upper hinge bracket and thrust washers (2). Set the door aside. Retain the upper hinge bracket thrust washers for opposite side hinge bracket installation.

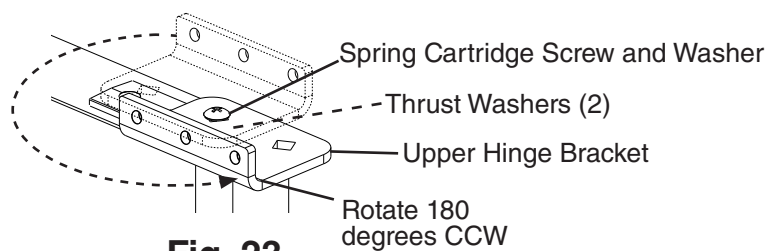

Fig. 23

- 5) Remove the filler screws from the opposite side upper hinge bracket holes and mount them into the holes of the removed upper hinge bracket. **NOTICE! Be sure to reuse the hinge bracket screws for mounting the hinge bracket as the hinge bracket screws are 5×12 and filler screws are 5×10.**
- 6) While maintaining a hold on the lower door, remove the lower hinge bracket from the cabinet, then lower the door off the center hinge bracket and set aside. See Fig. 24. Retain the center hinge thrust washers for opposite side installation.
- 7) Remove the center hinge bracket from the cabinet. Remove the filler screws from the opposite side lower and center hinge bracket holes and mount them into the holes of the removed lower and center hinge brackets. **NOTICE! Be sure to reuse the hinge bracket screws for mounting the hinge brackets as the hinge bracket screws are 5×12 and filler screws are 5×10.**

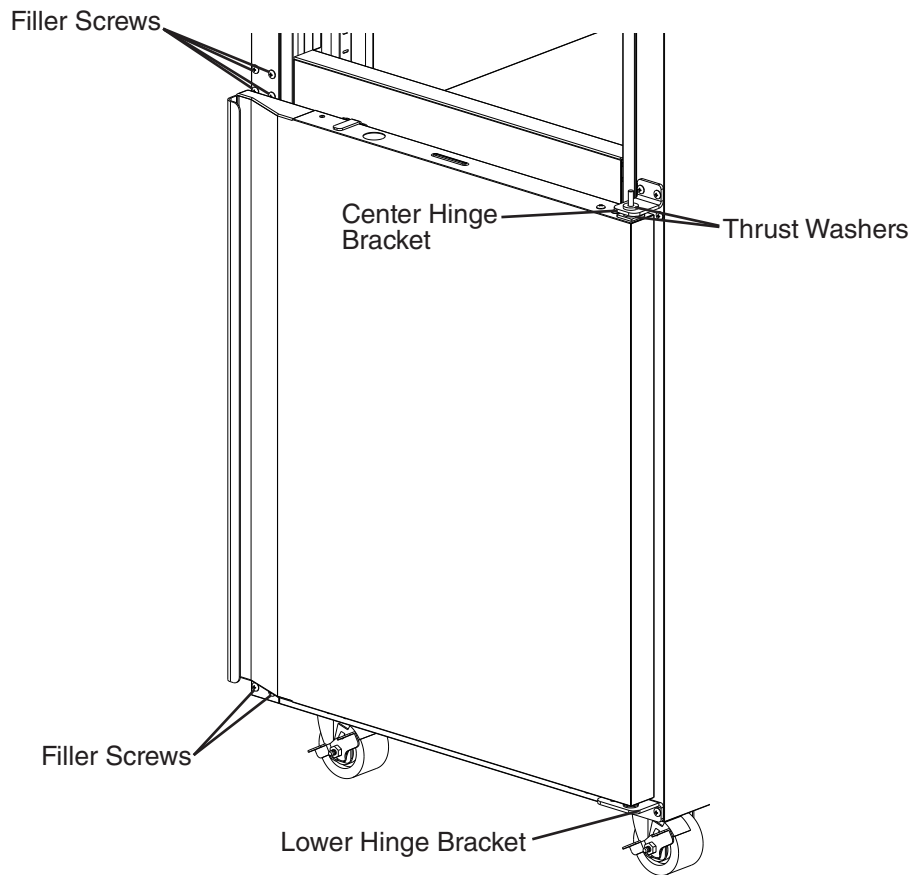

Fig. 24

- 8) Remove the door latch from the lower door. See Fig. 25.

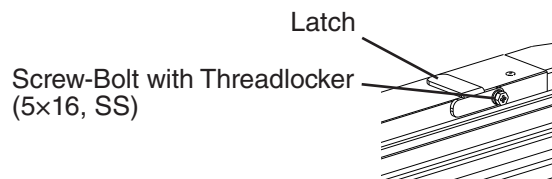

Fig. 25

- 9) Remove the lower hinge bracket spring cartridge screw, washer, and thrust washers from the door. Set the door aside. Next, secure the lower hinge bracket to the opposite side. Make sure the lower thrust washers are in place. See Fig. 26.

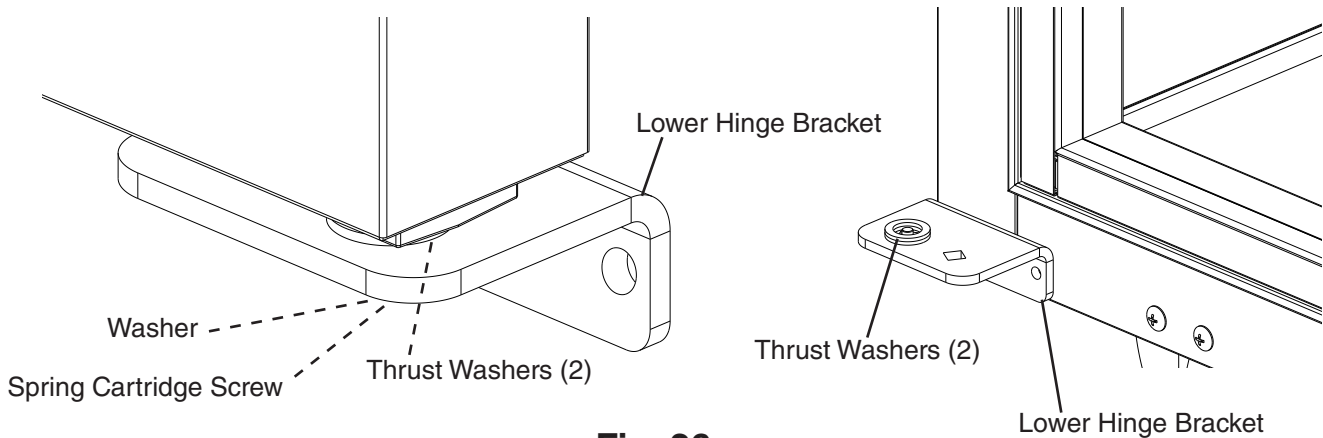

Fig. 26

- 10) Rotate the former upper door 180 degrees to its new lower door orientation.
NOTICE! Care should be taken not to damage the door.
- 11) Attach the lower door latch to the newly rotated lower door (former rotated upper door). See Fig. 27.

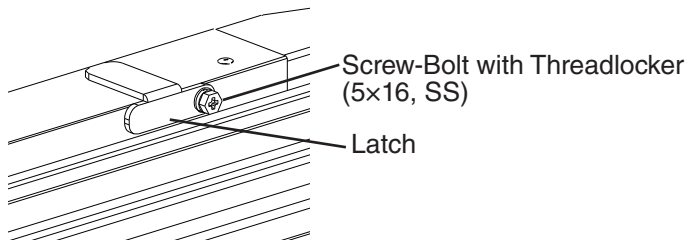

Fig. 27

- 12) Make sure the lower hinge bracket thrust washers (2) are in place, then with the lower door (former rotated upper door) in the maximum open position, place the door onto the lower hinge bracket. See Fig. 28. The spring cartridge shaft should slide into the lower hinge bracket and be flush with the bottom of the lower hinge bracket.

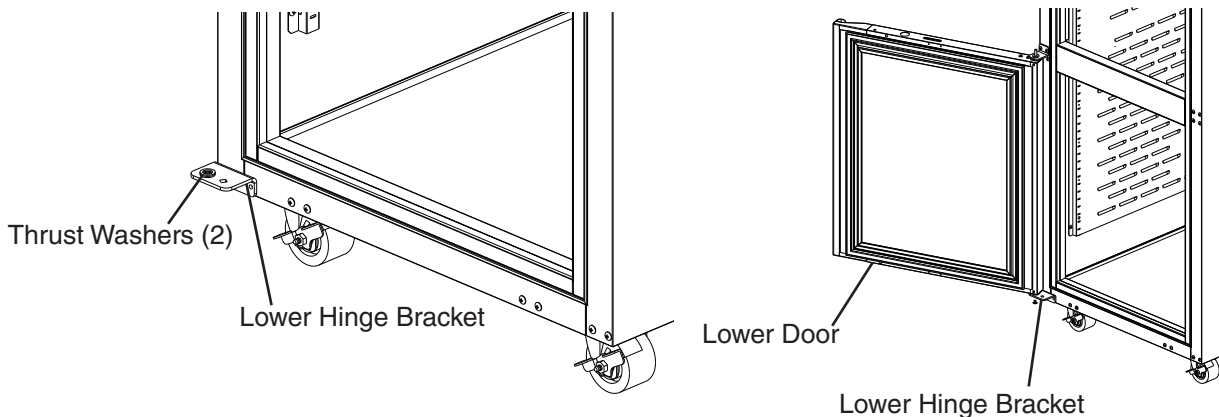

Fig. 28

- 13) Place the center hinge bracket lower pin with thrust washer into the nylon bearing on top of the door. Secure the center hinge bracket to the cabinet. See Fig. 29.

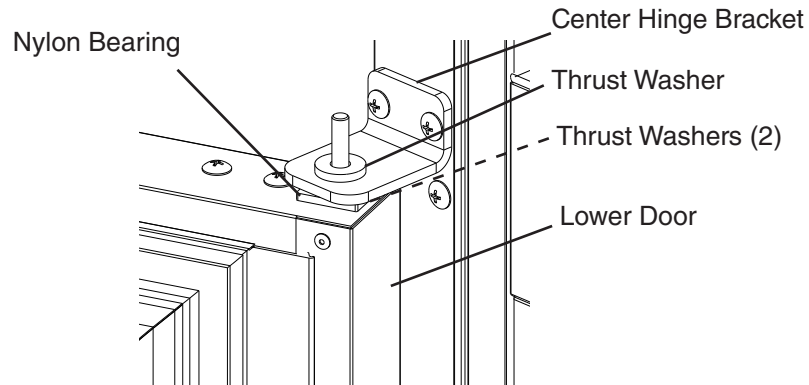

Fig. 29

- 14) Secure the door to the lower hinge bracket using the spring cartridge screw and washer.
Note: Be sure thrust washers (2) are in place between lower hinge bracket and door.
See Fig 30.
- 15) Verify the door swing.

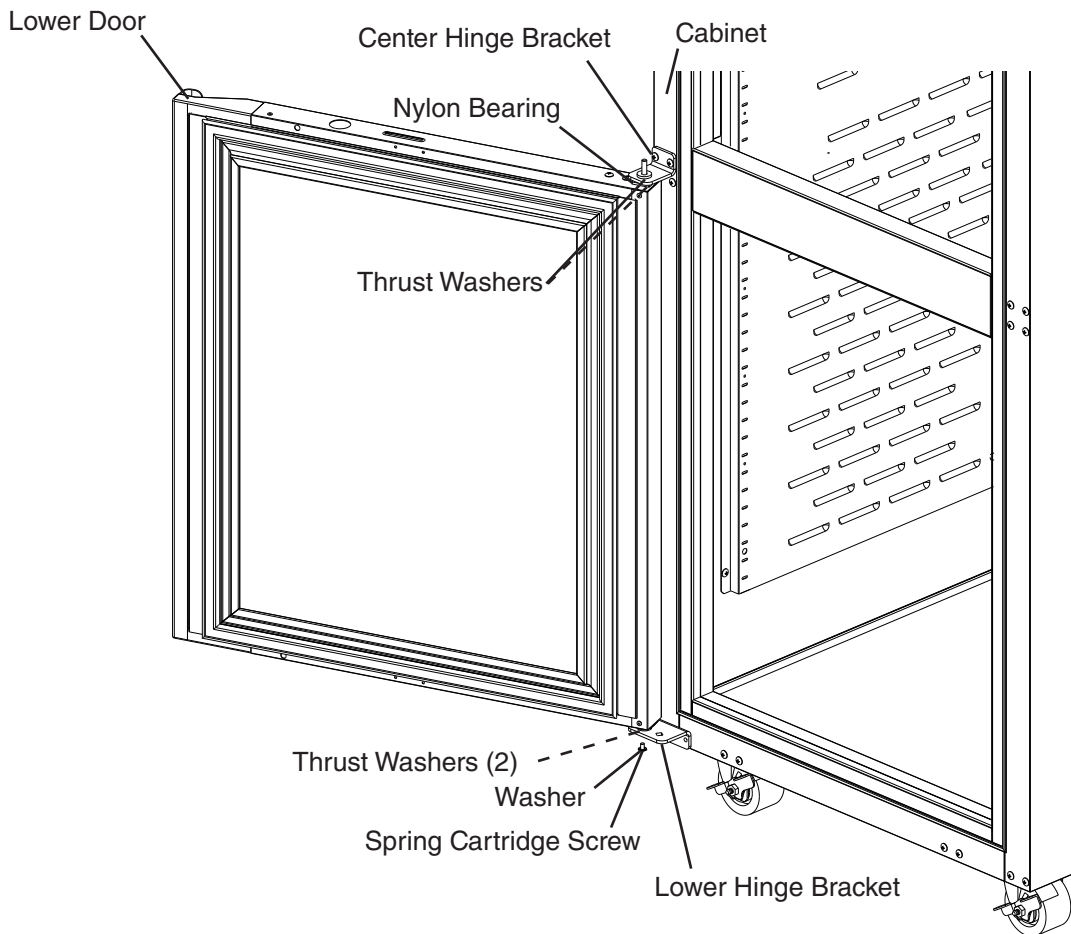

Fig. 30

- 16) Make sure the center hinge bracket upper thrust washer is in place on top of the center hinge bracket upper pin.
- 17) Align the upper hinge bracket to the upper door in the orientation that allows for closed door installation. Make sure the thrust washers are in place between the upper hinge bracket and upper door, then secure the upper hinge bracket to the door using the spring cartridge screw and washer removed earlier in step 9. The spring cartridge shaft should slide into the upper hinge bracket and be flush with the top of the doors upper hinge bracket.
- 18) With the door in the closed position, place the upper doors nylon bearing onto the center hinge bracket upper pin, then secure the upper hinge bracket to the cabinet with the upper door in the closed position. See Fig. 31.
- 19) Verify the door swing. Move the control panel hole plugs to the other side, then replace and secure the control panel in its correct position, then lower the front panel in its correct position. Verify the door switch and lock function and adjust as necessary.

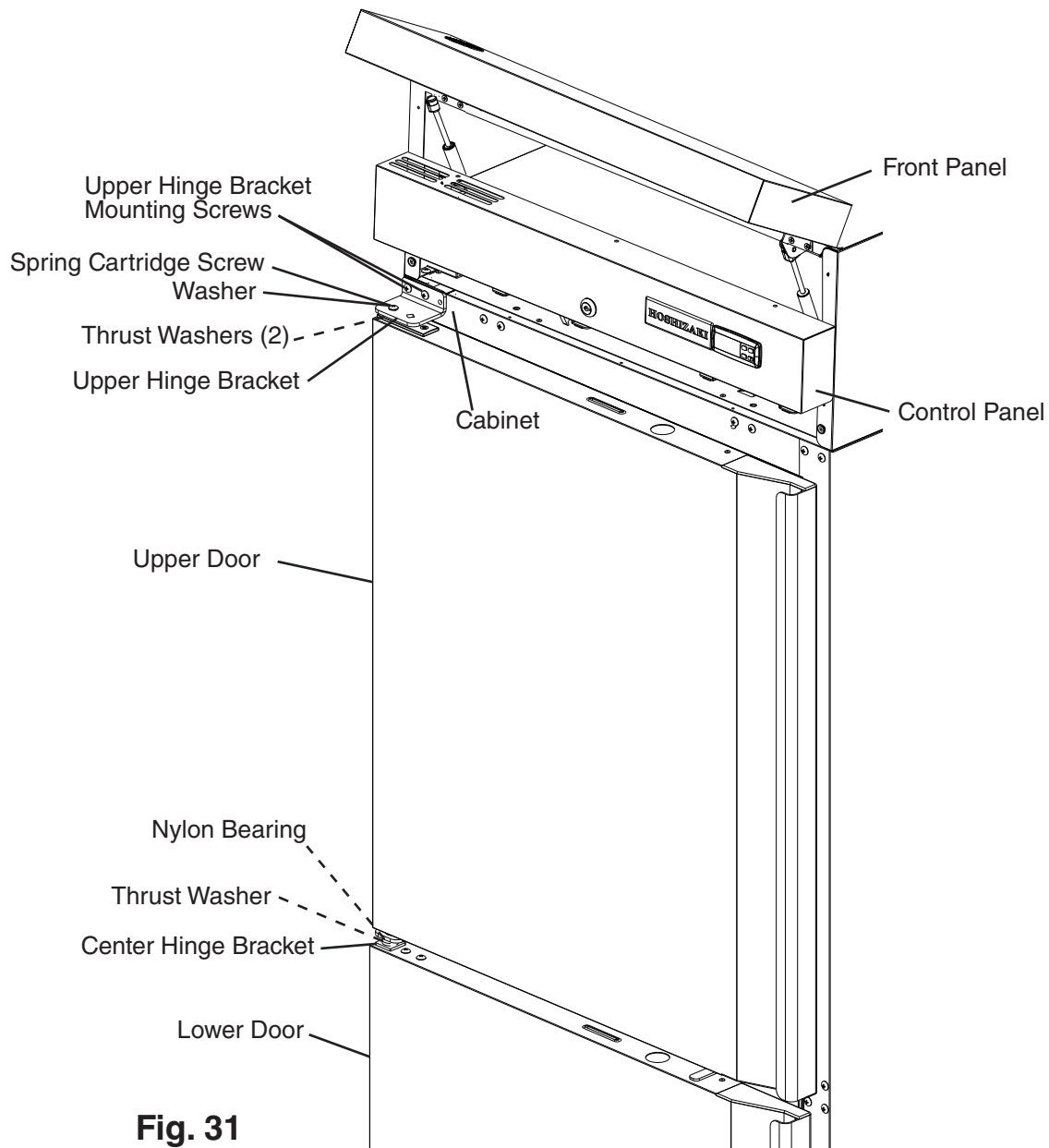



Fig. 31

F. Electrical Connection

WARNING

- Electrical connection must meet national, state, and local electrical code requirements. Failure to meet these code requirements could result in death, electric shock, serious injury, fire, or severe damage to equipment.
 - This appliance requires an independent power supply of proper capacity. See the nameplate for electrical specifications. Failure to use an independent power supply of proper capacity can result in a tripped breaker, blown fuse, damage to existing wiring, or component failure. This could lead to heat generation or fire.
 - **115VAC Models: THIS APPLIANCE MUST BE GROUNDED:** This appliance is equipped with a NEMA 115VAC 5-15 three-prong grounding plug  to reduce the risk of potential shock hazards. It must be plugged into a properly grounded, independent 3-prong wall outlet. If the outlet is a 2-prong outlet, it is your personal responsibility to have a qualified electrician replace it with a properly grounded, independent 3-prong wall outlet. Do not remove the ground prong from the plug and do not use an adapter plug. Failure to follow these instructions may result in death, electric shock, or fire.
 - **208/230VAC Models: THIS APPLIANCE MUST BE GROUNDED:** This appliance is equipped with a NEMA 208-230 L14-20 four-prong locking, grounding plug  to reduce the risk of potential shock hazards. It must be plugged into a properly grounded, independent 4-prong locking wall outlet. If the outlet is a 3-prong outlet or a 4-prong non-locking outlet, it is your personal responsibility to have a qualified electrician replace it with a properly grounded, independent 4-prong locking wall outlet. Do not remove the ground prong from the plug and do not use an adapter plug. After plugging in, twist the plug clockwise to lock it into place. Failure to follow these instructions may result in death, electric shock, or fire.
 - To reduce the risk of electric shock, do not touch the plug with damp hands.
 - Press and hold the standby button to turn "OFF" before unplugging the appliance to reduce the risk of electric shock.
 - Do not use an extension cord.
 - Do not use an appliance with a damaged power cord. The power cord should not be altered, jerked, bundled, weighed down, pinched, or tangled. Such actions could result in electric shock or fire. To unplug the appliance, be sure to pull the plug, not the cord, and do not jerk the cord.
 - The GREEN ground wire in the factory-installed power cord is connected to the appliance. If it becomes necessary to remove or replace the power cord, be sure to connect the power cord's ground wire.
- Usually an electrical permit and services of a licensed electrician are required.
 - The maximum allowable voltage variation is ± 10 percent of the nameplate rating.

G. Final Checklist

- 1) Is the appliance level?
- 2) Are the legs or casters properly tightened to the appliance?
- 3) If using casters, have the front casters been locked?
- 4) Is the appliance in a site where the ambient temperature is as specified below all year around?
 - Heated Holding Cabinet 45°F to 104°F (7°C to 40°C)
- 5) Has the shipping carton, tape, and packing material been removed from the appliance?
Has the protective plastic film been removed from the exterior panels on all models and from the interior door panels on solid door models?
- 6) Has the appliance and accessories been checked for shipping damage?
- 7) Has the power supply voltage been checked or tested against the nameplate rating?
Is the power supply a properly grounded, independent wall outlet? Does the electrical connection meet all national, state, and local code and regulation requirements?
- 8) Have the shelves been properly installed?
- 9) Has the humidity vent been properly set?
- 10) Has the end user been given the instruction manual, instructed on how to operate the appliance, and given the importance of the recommended periodic maintenance?
- 11) Has the end user been given the name and telephone number of an authorized service agent?
- 12) Has the warranty card been filled out and forwarded to the factory for warranty registration?

III. Operating Instructions

A. Important Notes About Usage

⚠ WARNING

- Some surfaces are hot, care should be taken to avoid burns.
- Only qualified service technicians should install and service the appliance.
- Wear appropriate personal protective equipment (PPE) when handling hot pans or product and when servicing the appliance.
- Failure to install, operate, and maintain the appliance in accordance with this manual may adversely affect safety, performance, component life, and warranty coverage.
- To reduce the risk of electric shock, do not touch the plug with damp hands.
- Do not splash, pour, or spray water directly onto or into the appliance. This might cause short circuit, electric shock, corrosion, or failure.
- The appliance is not intended for use by persons (including children) with reduced physical, sensory, or mental capabilities, or lack of experience and knowledge, unless they have been given supervision or instruction concerning use of the appliance by a person responsible for their safety.
- Care should be used when placing items on top of the appliance. Foreign objects or moisture could enter the appliance and result in electric shock or fire.

⚠ WARNING, continued

- Children should be properly supervised around the appliance.
- Do not climb, stand, or hang on the appliance or doors or allow children or animals to do so. Do not climb into the appliance or allow children or animals to do so. Death or serious injury could occur or the appliance could be damaged.
- Be careful not to pinch fingers when opening and closing the doors. Be careful when opening and closing the doors when children are in the area.
- Open and close the doors with care. Opening the doors too quickly or forcefully may cause injury or damage to the appliance or surrounding equipment.
- Keep the area around the appliance clean. Dirt, dust, or insects in the appliance could cause harm to individuals or damage to the equipment.
- Do not throw anything onto the shelves or load any single shelf with more than 120 lb. (54.5 kg) of product. They might fall off and cause injury.
- Do not block air inlets or outlets, otherwise heating performance may be reduced.
- Do not tightly pack the cabinet. Allow some space between items to ensure good air flow. Also allow space between items and interior surfaces.
- Food storage and handling must comply with applicable codes and regulations.
- Do not place any product on the floor of the cabinet. All product must be placed on properly installed shelves.

⚠ WARNING, continued

- This appliance is designed for keeping food items warm until served.
- Do not use this cabinet to heat COLD foods. Holding food at temperatures of less than 140°F (60°C) may be dangerous. Temperatures under 140°F (60°C) promote the growth of harmful bacteria and toxins in some foods.
- The temperature danger zone is considered 40°F to 140°F (4.4°C to 60°C) and rapid bacteria growth zone is considered 70°F to 120°F (21°C to 49°C).
- Prevent potentially hazardous foods from spending more than four (4) hours combined total time in these zones.
- Employ sanitary methods. Use for any other purposes could cause deterioration of stored items and contamination of items.

NOTICE

- Protect the floor when moving the appliance to prevent damage to the floor.
- Keep ventilation openings, in the appliance enclosure or in the built-in structure, clear of obstruction. Blockage of airflow could negatively affect performance and damage the appliance.
- To prevent deformation or cracks, do not spray insecticide onto the plastic parts or let them come into contact with oil.
- To avoid damage to the gasket, use only the door handle when opening and closing.
- Do not leave the doors open.

B. Startup

WARNING

- All parts are factory-adjusted. Improper adjustments may adversely affect safety, performance, component life, and warranty coverage.
- To reduce the risk of electric shock, do not touch the plug with damp hands.

- 1) Plug the appliance into the electrical outlet. At startup, there is a slight delay before the heater(s) start. **WARNING! To reduce the risk of electric shock, do not touch the plug with damp hands.**
- 2) If the cabinet temperature is not displayed on the control module, press and hold the "U" button (on/off button) for 2 seconds. See Fig. 32.
- 3) Allow the appliance to heat up prior to loading it with food products.

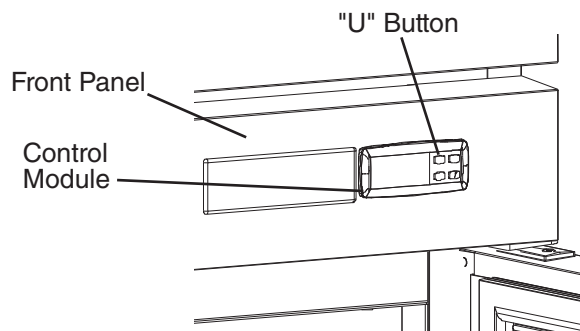

Fig. 32

C. Controls and Adjustments

1. Temperature Display

The cabinet temperature is displayed on the control module. See Fig. 33.

The display is in °F. To convert from °F to °C, see "II.C.3. Changing the Temperature Display Scale (°F or °C)."

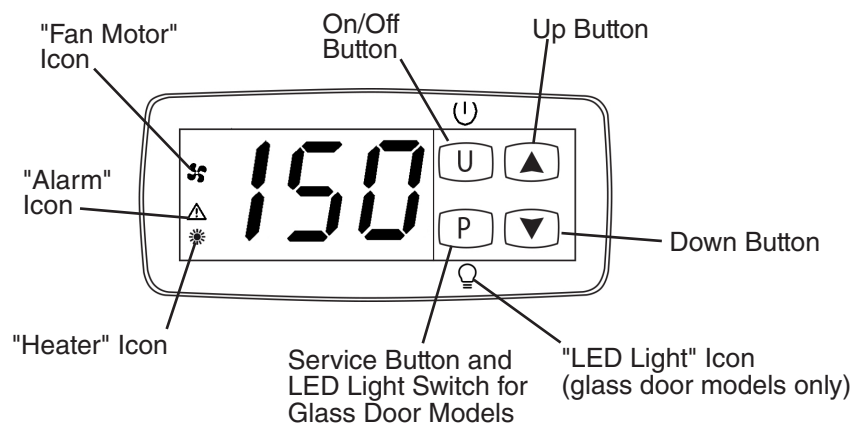

Fig. 33

2. Adjusting the Temperature Setpoint

The temperature setpoint is the value for the cabinet temperature. The temperature differential for the heater(s) to turn on or off is $\pm 1.5^{\circ}\text{F}$ ($\pm 0.8^{\circ}\text{C}$) of the temperature setpoint. For example, the temperature setpoint of 150°F (65.5°C), the heater(s) come on at 148.5°F (64.7°C) and the heater(s) go off at 151.5°F (66.3°C). If necessary, adjust the temperature setpoint as follows:

- 1) To change the temperature setpoint, press and release the "P" button or the up or down button. The current temperature setpoint appears. Press the up or down button until the desired value is displayed. After a few seconds, the display returns to the current cabinet temperature and the temperature setpoint is saved.
 - Heated Holding Cabinet temperature setpoint is adjustable between 80°F and 180°F (26.6°C and 82.2°C). **The factory default is 150°F (65°C).**

3. Changing the Temperature Display Scale ($^{\circ}\text{F}$ or $^{\circ}\text{C}$)

There are 4 temperature display settings from which to choose.

The factory temperature display default is F0 for $^{\circ}\text{F}$ whole number.

For a whole number temperature display scale value, select F0 or C0.

For a temperature display scale value to one decimal point, select F1 or C1.

Display Setting	Temperature Display Example
F0 - Factory Default	150°F
C0	65°C
F1	150.0°F
C1	65.0°C





To change the temperature display setting, follow the steps below.

- 1) Press the "U" and "P" buttons together for 5 seconds. r.uP is displayed.
- 2) Press the "P" button. The current display setting (F0, F1, C0, or C1) and r.uP start flashing.
- 3) Press the up or down button until the desired temperature display setting appears.
- 4) Press the "P" button to save the selection. r.uP is displayed. To return to normal display mode, press and hold the "U" button for 5 sec. Display returns to normal display mode. If no other button is pressed after pressing the "P" button, 25 sec. later, display returns to normal display mode.

Note: If no selection is saved within 30 seconds, the display returns to normal mode and the temperature display setting remains unchanged.

D. Control Module Icons

Control module icons inform you of energized components and if the appliance is in alarm. Note: Icons flash when components are called for during a timed lockout or the door is open. Once the timer terminates or the door is closed, the icons go solid and components energizes. See Fig. 34.

Control Module Icons	
Icon	Meaning
	Heater(s) Heater(s) energized. Heater(s) de-energize when door is open.
	Fan Motor Fan motor energized. Fan motor de-energizes when door is open.
	Alarm Appliance is in alarm. See "III.F. Alarm Safeties" for details.
	LED Light (glass door models) Glass door cabinet LED light. The cabinet LED light is controlled by the "P" service button.

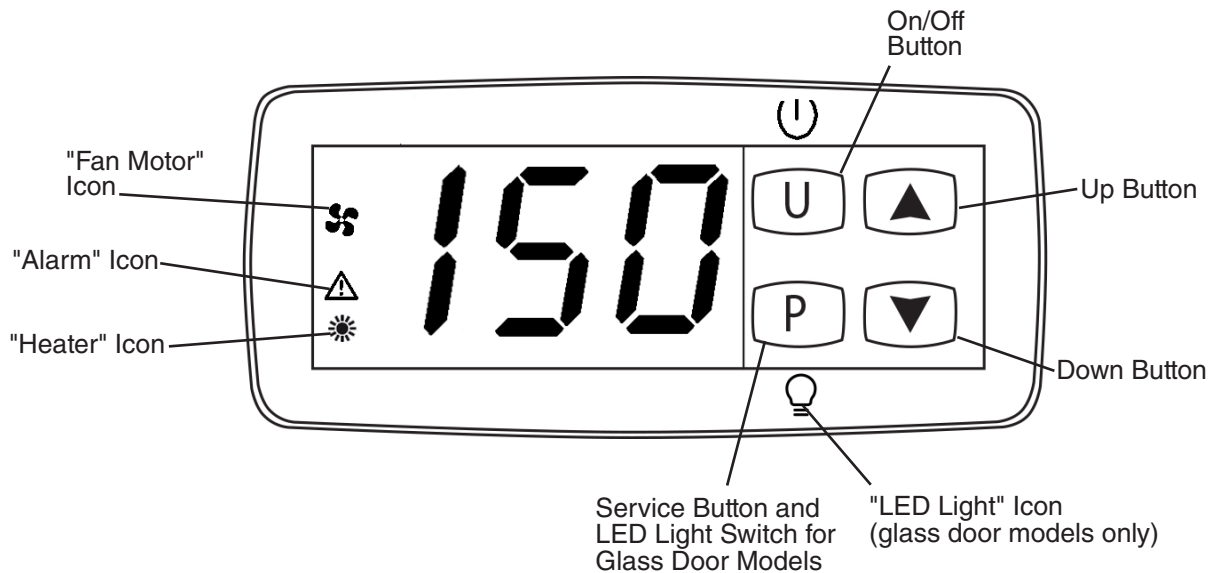

Fig. 34

E. Food Storage

WARNING

- This appliance is designed for storage of pre-cooked food. Employ sanitary methods.
- Holding food at temperatures of less than 140°F (60°C) may be dangerous. Temperatures under 140°F (60°C) promote the growth of harmful bacteria and toxins in some foods.
- Do not block the cabinet air inlet or outlet, otherwise heating performance may be reduced.
- Do not tightly pack the cabinet. Allow some space between items to ensure good air flow. Also allow space between items and interior surfaces.
- Do not place any product on the floor of the cabinet. All product must be placed on properly installed shelves.
- Do not put cool or uncooked foods in the cabinet. Cook them first, or they will lower the cabinet temperature and could deteriorate other foods in the cabinet or overload the appliance.
- All foods should be wrapped in heat resistant wrap or stored in sealed containers. Otherwise foods may dry up, pass their smells onto other foods, result in poor appliance performance, or increase the likelihood of cross-contamination.
- Do not store items near the air outlet. They might dry out and crack or break causing a risk of injury or contamination of other food.

F. Alarm Safeties

Alarm signals are designed to protect the appliance and food product. These alarms give information or warnings in the event the appliance is operating out of acceptable parameters. Should one of the alarms occur, follow the instructions in the table below to address the alarm. The alarm code and alarm icon flash with audible alarm.

Alarm Signals		
Alarm Code	Problem	Corrective Action/Reset Details
oP	Door Switch Alarm: Door has remained open for more than 2 minutes.	If obvious corrections such as closing doors does not correct the alarm, call a qualified service technician.
	Door Is Open or The Door Switch has failed.	Beeps continuously after 2 min. To silence the alarm, press and release any button.
(-)E1	Cabinet Thermistor Malfunction Alarm	Call a qualified service technician. Beeps continuously. To silence the alarm, press and release the up button.
	Cabinet thermistor has failed.	Appliance cycles 1 min. on, 10 min. off. -E1 - Cabinet thermistor out of place or open. E1 - Cabinet thermistor shorted.
Hi	High Temperature Alarm	If obvious corrections do not bring temperature back in range, call a qualified service technician.
	Cabinet temperature has remained above 225°F (107.2°C) for more than 2 minutes.	Beeps continuously. To silence the alarm and clear "Hi" from the display, press and release any button. The alarm icon stays on. Automatically resets when temperature returns to normal.
Lo	Low Temperature Alarm	If obvious corrections do not bring the temperature back in range, call a qualified service technician.
	Cabinet temperature has remained below 80°F (26.6°C) for more than 2 minutes.	Beeps continuously. To silence the alarm and clear "Lo" from the display, press and release any button. The alarm icon stays on. Automatically resets when temperature returns to normal.
UHi	High Voltage Alarm (140VAC±5% or more)	Call a qualified service technician.
ULo	Low Voltage Alarm (100VAC±5% or less)	Beeps until voltage is in range. The heater(s) de-energize if voltage protection operates. The voltage safeties automatically reset when voltage is corrected.

G. Heating Performance

Be sure the appliance is properly installed and located for optimum heating performance. If heating performance is not at its optimum level, check the following items:

- Activity of the Doors: Door(s) opened too often or doors left open.
- Cabinet too tightly packed or cabinet air inlet/outlet blocked. Allow some space between items to ensure good air flow.
- Cold or uncooked foods inside. Remove the foods. Replace them back in the appliance after they have been warmed or cooked.
- Ambient temperature out of range.
- Temperature setpoint too low. Adjust to a higher temperature setpoint.
- When lower humidity is desired. Open the humidity vent located in the top panel inside the cabinet.

IV. Cleaning and Maintenance Instructions

A. Cleaning

⚠ WARNING

- Before cleaning the appliance, press and hold the "U" button to turn "OFF" the appliance, unplug the appliance to prevent electric shock by unexpected entrance of water into the appliance or injury by moving parts. To reduce the risk of electric shock, do not touch the plug with damp hands.
- Before cleaning the appliance, remove all foods, trays, and containers.
- Allow the appliance to cool before attempting to touch and clean potentially hot surfaces.
- Do not splash water directly onto the appliance. This might cause a short circuit, electric shock, corrosion, or failure.
- Carefully follow instructions provided with cleaning and sanitizing products.

NOTICE

- To prevent damage to the plastic surfaces, do not use the following: hot water, thinner, benzene, alcohol, petroleum, soap powder, polishing powder, alkaline cleaner, acid, scouring pad and especially those strong cleaners for use on a ventilating fan or a cooking range.
- To prevent corrosion and damage to stainless steel surfaces, use only products formulated for use on stainless steel appliances. Do not use steel wool, abrasive products, or products containing sodium hypochlorite (chlorine bleach).
- Use a clean cloth for cleaning.

1. Exterior

Wipe the exterior occasionally with a clean, soft cloth. Use a damp cloth containing a neutral cleaner to wipe off oil or dirt buildup. Clean any rust colored spots using a non-abrasive cleanser.

2. Cabinet Interior

Spills should be wiped up promptly to avoid unpleasant odors. The cabinet interior should be cleaned periodically with a mild soap or detergent and warm water. **NOTICE! Do not use hot water to clean the cabinet interior.**

3. Door Gaskets

Door gaskets should be cleaned regularly with mild soap and warm water to remove dirt and grease.

4. Shelves

Remove and clean regularly.

B. Maintenance

The appliance must be maintained in accordance with the instruction manual. Consult with your local Hoshizaki Certified Service Representative about maintenance service. Failure to maintain the appliance in accordance with this manual may adversely affect safety, performance, component life, and warranty coverage.

WARNING

- Only qualified service technicians should service the appliance.
- Press and hold the "U" button to turn "OFF" the appliance, unplug the appliance before performing maintenance or troubleshooting to prevent electric shock or injury by moving parts. To reduce the risk of electric shock, do not touch the plug with damp hands.
- Before performing maintenance or troubleshooting, remove all foods, trays, and containers.

1. Power Supply Connection

If the plug or power cord is damaged, contact your local Hoshizaki service representative or local Hoshizaki distributor immediately and ask for repairs.

All other maintenance or service on this appliance should be performed in accordance with the Hoshizaki Service Manual by a qualified service technician.

V. Preparing the Appliance for Periods of Non-Use

When shutting down the appliance for periods of non-use, follow the instructions below.

⚠ WARNING

- Prevent the doors from closing to reduce the risk of children getting trapped.
- To reduce the risk of electric shock, do not touch the plug with damp hands.

NOTICE

Clean the appliance. See "IV.A. Cleaning" for details.

- 1) Before shutting down the appliance, remove all foods, trays, and containers.
- 2) Press and hold the "U" button on the control module until a dot appears in the display, then unplug the appliance from the electrical outlet. See Fig. 35.

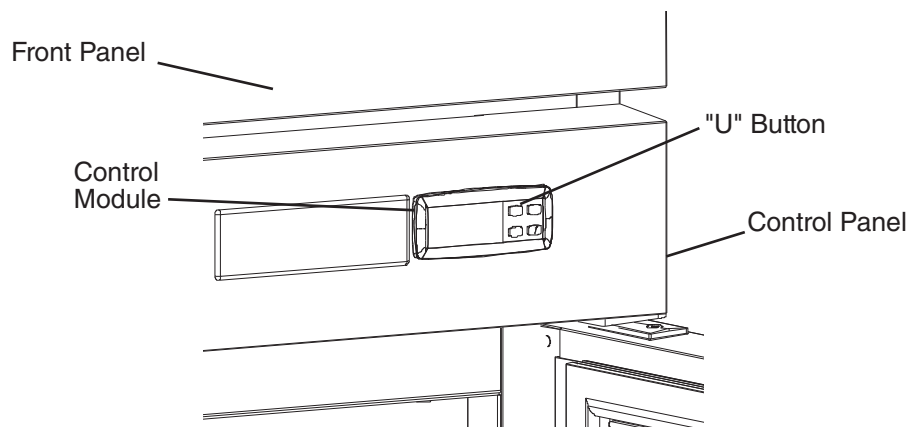

Fig. 35

VI. Disposal

DANGER

Risk of Fire or Explosion Flammable Refrigerant Used

- Follow handling instructions carefully in compliance with U.S. government regulations.
- Dispose of properly in accordance with federal or local regulations.

Risque De Feu Ou D'Explosion Le Frigorigène Est Inflammable

- Suivre attentivement les instructions de manipulation conformément à la réglementation gouvernementale.
- Éliminer conformément aux règlements fédéraux ou locaux.

WARNING

Remove the door to reduce the risk of children getting trapped. Leave the shelves in place so that children may not easily climb inside.

The appliance must be disposed of in accordance with applicable national, state, and local codes and regulations.

