

# Premium Upper and Lower Body Exerciser

INSTRUCTION MANUAL

REF 10-0709

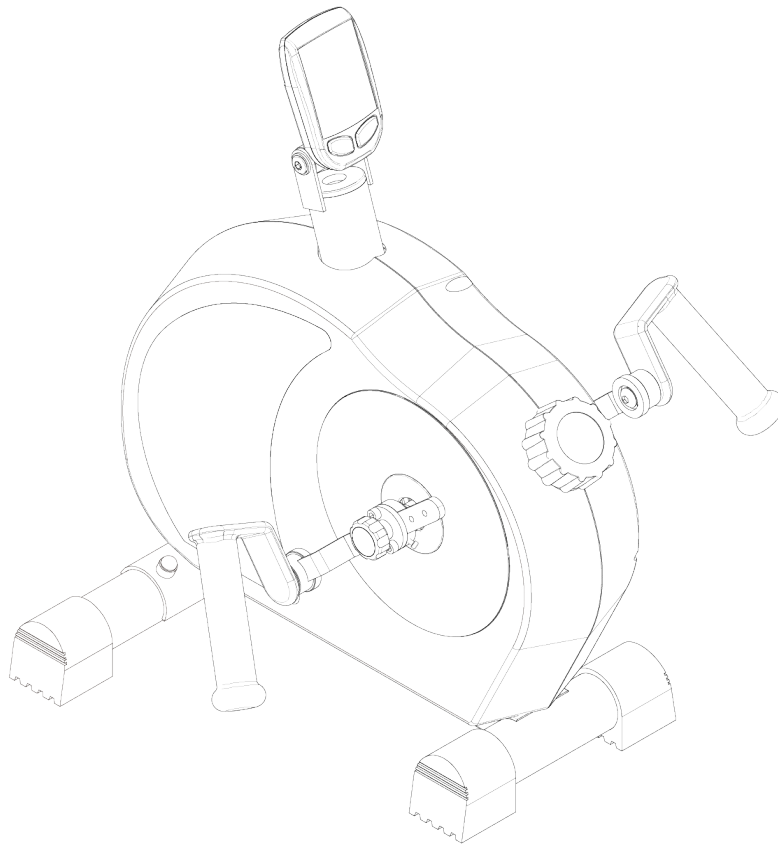

**GANDo<sup>®</sup>**

# **SAFETY PRECAUTIONS**

## **Before You Begin**

This exercise equipment was designed and built for optimum safety. However, certain precautions apply whenever you operate a piece of exercise equipment. Be sure to read the entire manual before you assemble and operate this machine. Also, please note the following safety precautions:

1. Read the following instructions carefully before using this machine.
2. Consult your physician before beginning this or any other exercise program.
3. Always wear proper exercise apparel when using this machine.
4. If you feel faint, dizzy, or pain while operating this machine, stop exercising immediately!
5. Keep children and pets away from this machine while in use.
6. Only one person can use this machine at a time.
7. Make sure your machine is correctly assembled before using.
8. Do not operate this machine if it is damaged.
9. Do not insert any objects into the machine's openings.
10. Keep clothes, jewelry, and loose items away from moving parts.



### **WARNING**

**BEFORE BEGINNING ANY EXERCISE PROGRAM, CONSULT YOUR PHYSICIAN. THIS IS ESPECIALLY IMPORTANT FOR INDIVIDUALS OVER THE AGES OF 35 OR PERSONS WITH PRE-EXISTING HEALTH PROBLEMS. READ ALL INSTRUCTIONS BEFORE USING THIS EQUIPMENT. WE ASSUME NO RESPONSIBILITY FOR PERSONAL INJURY OR PROPERTY DAMAGE SUSTAINED BY OR THROUGH THE USE OF THIS OF PRODUCT.**



### **WARNING**

**Read all instructions carefully before operating this machine.**

**Retain this Owner's Manual for future reference.**

### **Thank you for your purchase of the Premium UBE Trainer**

At CanDo®, our goal is to provide high-quality and affordable products for Health, Wellness, Fitness & Active Aging. The Premium UBE Trainer can be used as an Upper Body Trainer or a Bike and will give you a versatile cardio workout while strengthening your muscles. Whatever your fitness level may be, the Premium UBE Trainer will work for you. We wish you continued success in your journey towards optimum health and fitness!

## **Assembly Overview:**

When you receive your new Premium UBE Trainer, some assembly is required. Assembly consists of attaching the support tubes, pedals/handles, and display. The following instructions explain the assembly. There are also detailed instructions on the display.

## **Please Note:**

All of the parts and screws needed for assembly are already in place on the unit.

# EXPLODED DRAWING

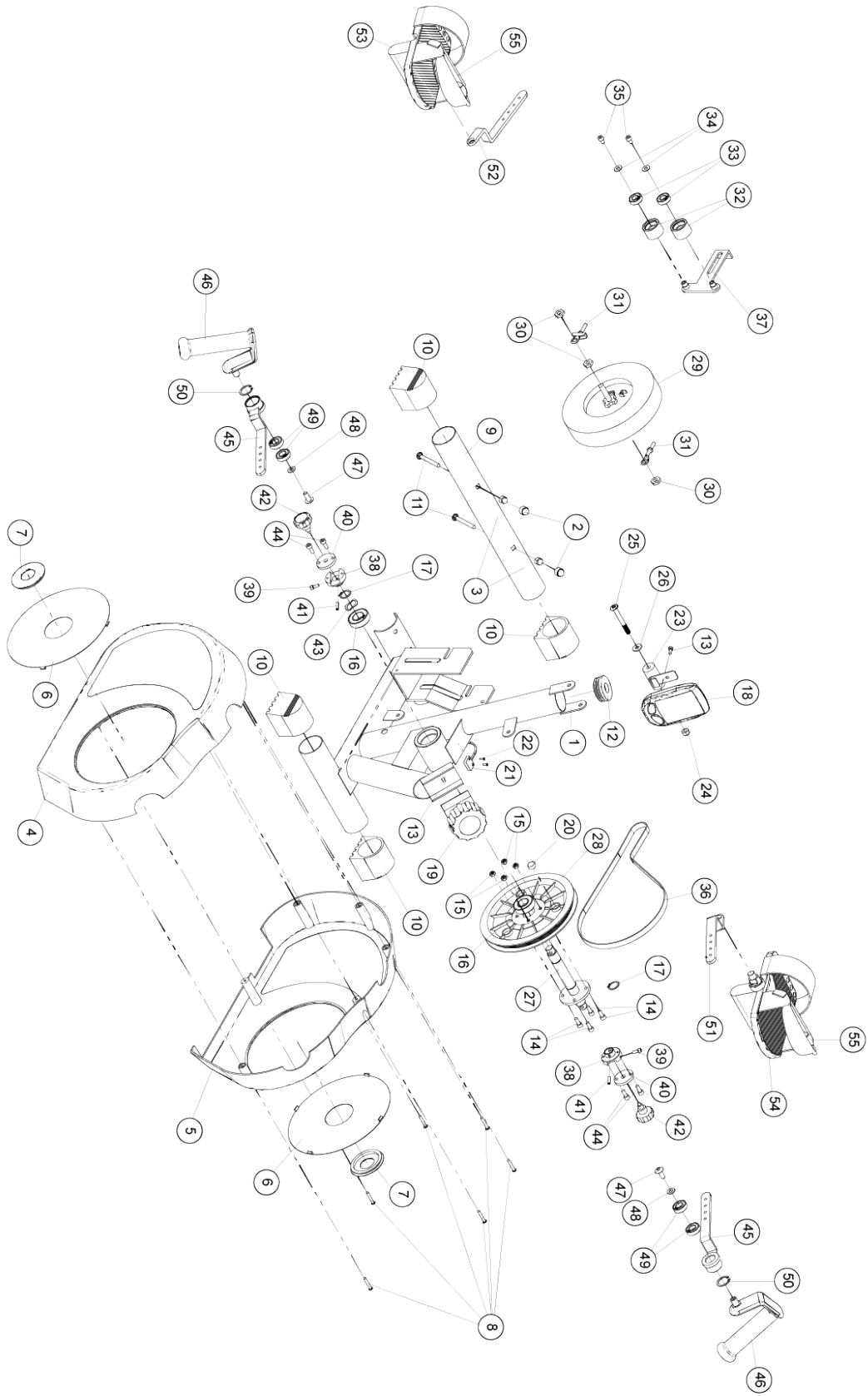

## PARTS LIST

No.	Qty	Description	NO.	Qty	Description
1	1	Frame	29	1	Magnetically flywheel
2	2	Nut trim -PU, black (with M8 nut)	30	3	Nut-3/8-26x5t
3	2	Screw cap - M8	31	2	Screw-flywheel
4	1	Plastic Cover - left cover - Black	32	2	Idler
5	1	Plastic Cover - Right cover - Black	33	2	Bearing
6	2	Mid-circle cover - Blue	34	2	Plate
7	2	Crank hole cover - soft PVC 60% black	35	3	Screw round head hexagon -M6 x P1.0 x 10L
8	6	Self-tapping screw	36	1	Belt-340-6J
9	1	Front ground pipe	37	1	Idler bracket
10	4	Pipe covers	38	2	Crank holder
11	2	Carriage screws M8x65L	39	2	Screw round head hex (white iron) - M5 x 12L
12	1	Round tube cover	40	2	Crank cover
13	2	Screw round head -M5 x 12L	41	2	Spring 5 x 20L
14	4	Screw round head M6 x 15L	42	2	Adjustable Knob M10 x 9L
15	4	Nut-M6	43	1	Wave washer
16	2	Bidirectional bearing	44	4	Screw -M6x15L stainless steel
17	2	C-plate	45	2	Hand grip plate
18	1	Console	46	2	Handle set
19	1	Magnetic controller	47	2	Screw round flat (umbrella head) inside hexagon-M8x12L
20	1	Magnetic	48	2	Washers d8.2 x D16× 1.6t
21	1	Reed induction line- 650L plus reed sensor	49	4	Bearing
22	2	Tapping Screws	50	2	R buckle-R28
23	1	Console adjustable holder	51	1	Crank - foot pedal (left) chrome
24	1	Nut-M8	52	1	Crank-foot pedal (right) chrome
25	1	Screw round flat (umbrella head) -M8x70L	53	1	Foot pedal left
26	1	Washer	54	1	Foot pedal right
27	1	Drive shaft	55	2	Foot straps
28	1	Belt Wheel			

## **NOTE**

All of the parts and screws needed for assembly are already in place on the unit.

## **TOOL SET:**

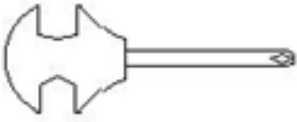

Screwdriver 1 pc



4mm Allen Key 1 pc

## **ASSEMBLY**

### ***Step 1 – installing the front tube***

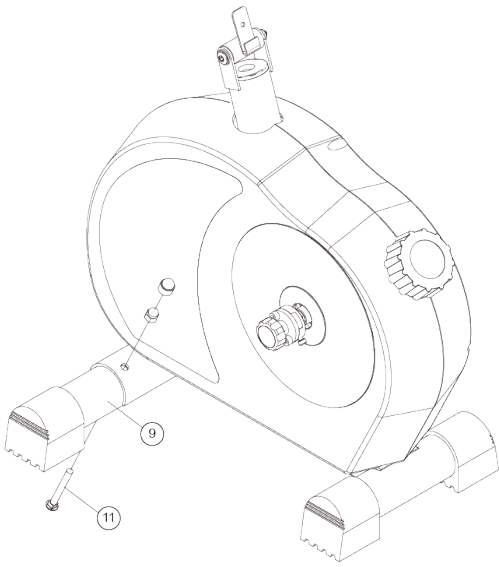

1. Use carriage screws (NO.11) and place the front tube set (NO.9) to be assembled with frame (NO.1).

### ***Step 2 – installation of console***

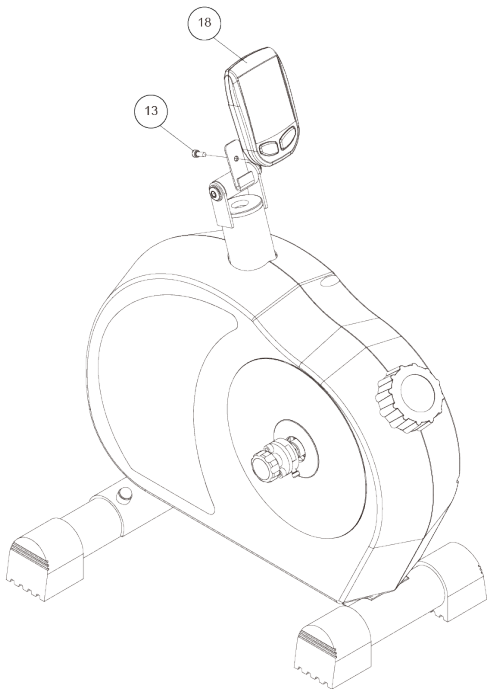

1. Insert two AAA batteries into the back of the display meter. Connect the console (No.18) to the console holder using the (No.13) screw.

# **ASSEMBLY**

## ***Step 3 – installation of adjustable hand crank set***

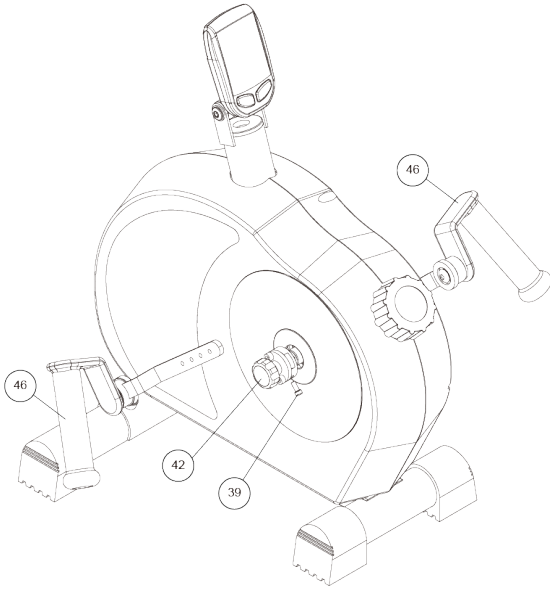

1. Install handles (NO.46) on the left and right sides (L and R as indicated).
2. Pull the (NO.42) knob outwards and tighten with the (NO.39) screw.
3. Confirm that the (NO.42) adjustable knob is properly installed and tightened.

## ***Step 4 – Change to pedal set***

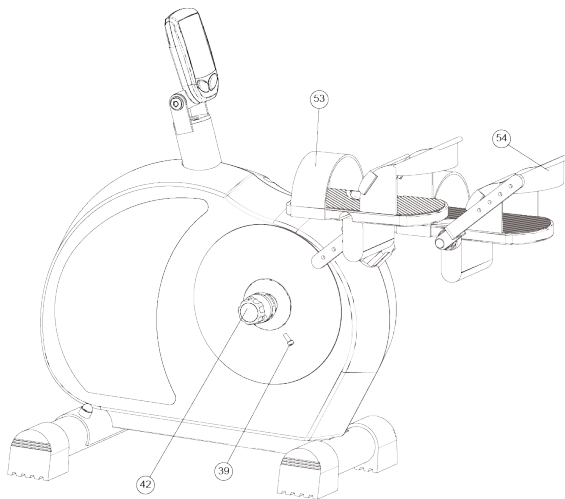

1. Install the left pedal (NO.53) and the right pedal (NO.54) on the proper sides as indicated.
2. Pull the (NO.42) knob outwards and tighten with the (NO.39) screw.
3. Confirm that the (NO.42) adjustable knob is properly installed and tightened.

# COMPUTER INSTRUCTIONS

## 1. MAIN DISPLAY



## 2. CONSOLE SPECIFICATION

CADENCE BAR GRAPHIC: 0 - 199 rpm per bar

RPM : 0 - 199 RPM

SPEED : 0 - 99 KM/H

PULSE : 30 - 240 BPM

Time : Count down setting range 1 - 99 Minutes

Count up range 00:01 - 99:59

### IMPORTANT SAFETY INSTRUCTIONS WARNING

**BEFORE BEGINNING THIS OR ANY OTHER EXERCISE PROGRAM, CONSULT A PHYSICIAN. THE PHYSICIAN CAN HELP YOU BETTER DETERMINE WHAT ACTIVITIES OR PROGRAMS ARE MOST SUITED FOR YOU. IF AT ANY TIME DURING THE WORKOUT YOU FEEL FAINT, OR EXPERIENCE CHEST PAINS OR SEVERE SHORTNESS OF BREATH, STOP EXERCISING IMMEDIATELY AND CONSULT A PHYSICIAN.**

The computer console uses AAA type batteries. Please install the supplied AAA batteries in the computer console before using.

## Battery Installation:

1. Remove the battery cover from the back of the computer.
2. Insert 2 AAA batteries into the battery compartment and reinstall the battery cover.
3. When battery working voltage is low, the 'Low Battery' indicator will show up on the console display.

## DISPLAY WINDOW

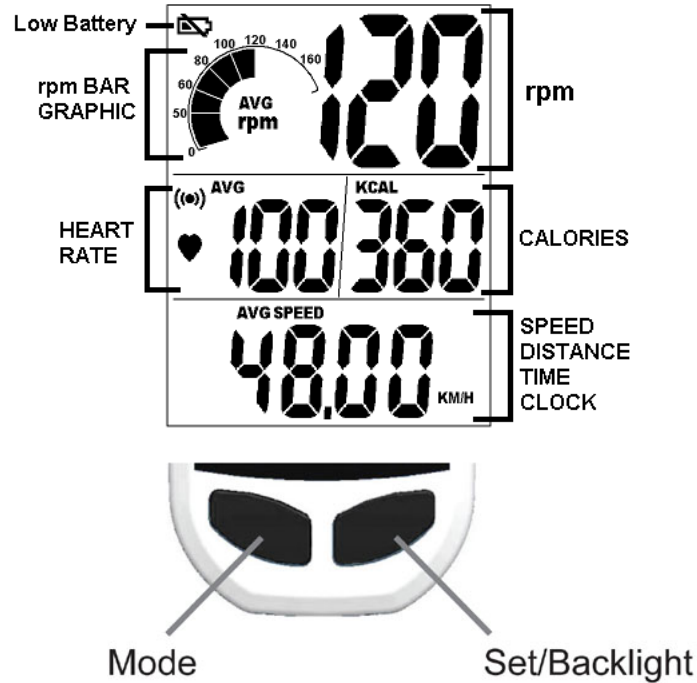

## TIME

“Time” is the length of time (min. / sec.)

The time will count up or count down during user pedaling. When pedaling has stopped, the timer will pause after 3 seconds.

## CADENCE & SPEED

“Cadence” is the measurement of how fast the cranks are rotating in RPM’s. The approximate speed of the bike is also displayed (MPH/KPH) in this section.

In addition to the MPH/KPH, a bar graph will be shown that allows the rider to keep track of the approximate cadence that has been achieved.

Average cadence or speed will automatically display after the rider stops pedaling for 3 seconds.

## DISTANCE

“Distance” is the measurement of the approximate distance achieved on the bike. This distance is based on the user riding a bike with tires that are the same size as the bike’s flywheel.

## KCAL

“Kcal” is the approximation of calories burned during your workout. The calories are calculated by measuring the rider’s instantaneous heart rate, age, and weight.

## HEART RATE (apply to HR featured models only)

This is the approximation of heart rate detected from the chest belt during the workout. Average heart

rate will be automatically shown after 3 seconds if the console cannot detect the current heart rate.

## QUICK Start

In Power Saving Mode, press any Key to bring the CONSOLE to 'QUICK START' active state.

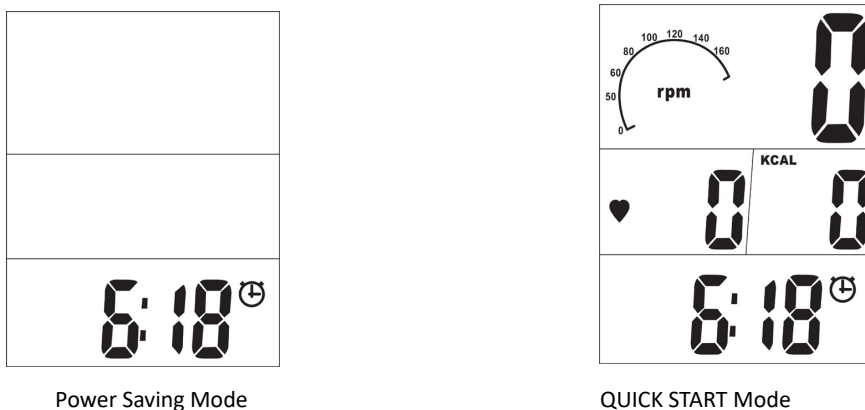

## MODE SELECT

Press 'MODE' key to select the *SPEED, DIST, TIME or CLOCK* display.

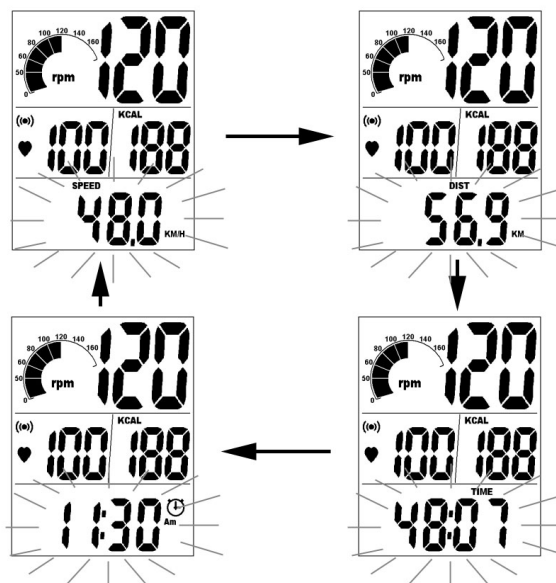

## ALARM Setting

Under the TIME MODE, press 'SET' key to select the Alarm display. The heart rate symbol will also flash to visually indicate that your heart rate is either above or below the selected target zone.

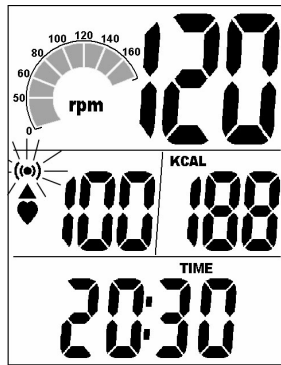

### Resetting all measured values

To clear all the measured values, press and hold 'SET' key under the TIME Mode for 3 seconds. All the measured values for AVG SPEED, AVG PULSE, TIME, DIST, KCAL will reset to zero.

### TIMER Setting

The TIMER displays the user's exercise time. If the user does not set the COUNT DOWN TIME, the TIME will count up from 00:00 to 99:59.

If the prior user set the COUNT DOWN TIME, the TIME will count down to **zero** with the flashing display, and the alarm will sound for 3 seconds. The TIME will change automatically from counting down to counting up from 00:01. The user can go into the TIMER setting from SPEED or DISTANCE Mode by pressing and holding the 'SET' key for 3 seconds.

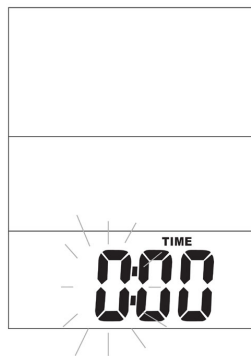

### CLOCK Setting

Under the CLOCK MODE, press and hold the 'SET' key, and the 12H or 24H will flash. Press the 'SET' key to switch from 12H to 24H. Press the 'MODE' key to flash the CLOCK HOUR, then Press 'SET' key to adjust the clock hour (0 – 24). Press the 'MODE' key again to flash the CLOCK MINUTE, then Press 'SET' key to adjust the clock minute (0 – 59).



### HEART RATE TARGET ZONES

Under SPEED or DISTANCE MODE, hold the "SET' key for 3 seconds to go into the setting. Press 'MODE' key to go to the heart rate target zones window.

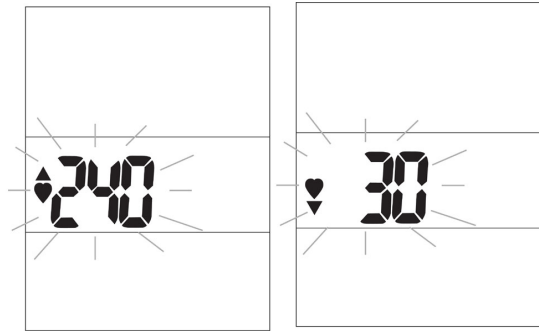

Press the 'SET' key to increase maximum heart rate limit. After setting the maximum heart rate, press the MODE key to adjust the minimum heart rate limit.

## PERSONAL DATA SETTING

Accurate personal data will make the calories burned more accurate. Under SPEED or DISTANCE MODE, hold the 'SET' key for 3 seconds to go into the setting, then continually press the 'MODE' key to get to the personal data windows.

1. Press the 'SET' key to select the gender. (Male or Female)
2. Press the 'MODE' key to go to the weight unit setting. Press the 'SET' key to select the weight (Lb or KG).  
**Note:** this change of metric units to imperial units will also affect the corresponding display unit (MPH/KPH and ML/KM).
3. Press the 'MODE' key to go to the weight setting. Press the 'SET' key to increase the weight by 0.5 Lb or 0.5 KG.

## TROUBLESHOOTING

### No Display on console

1. Press any key to bring the console to 'Quick Start' mode.
2. Ensure that the batteries are installed properly in the console and transmitter. If they are, install fresh batteries.

### No heart rate signal displayed

1. Ensure that your chest strap is worn correctly, and that there is moisture under the electrodes of the chest strap.
2. Relocate the bike away from any equipment that could potentially interrupt the radio frequency signal, such as a DVD player or television.

### RPM or heart rate does not change

1. Press the 'MODE key' repeatedly to toggle between SPEED (SPD), DISTANCE (DIST), TIME (TIME) and CLOCK (CLK) values.
2. Press and hold the 'SET key' repeatedly to clear past measured values, or go into setting and exit.

## **Cadence number jumps high or low**

1. Separate bikes that may be paired to the same console code and are cross-talking, or simply run transmitter pair stage again on the bike.
2. Relocate the bike to a different part of the room, away from any RF interference areas.

## **CAUTION**

**EXTERNAL INTERFERENCE MAY BE CAUSED BY OTHER ELECTRONIC DEVICES SUCH AS: NEARBY TELEVISIONS, STEREO EQUIPMENT, SPEAKERS, ELECTRICAL WIRE CABLING, ETC. IF YOU EXPERIENCE DISTURBANCES IN THE CONSOLE DISPLAY, TRY MOVING YOUR BIKE(S) AWAY FROM POTENTIAL RF INTERFERENCE AREAS.**

## **PLEASE NOTE:**

1. The console is designed as a sealed unit and is not meant to be opened other than for the sole purpose of installing batteries. Opening the unit will void the warranty.
2. To clean the console, lightly spray the monitor with an authorized cleaning / disinfectant solution and wipe dry with a soft towel. Use of any caustic cleaning solutions will void the warranty.
3. The console is NOT waterproof; only water resistant. Any excessive exposure to water will void the warranty.



Fabrication Enterprises Inc.

CanDo is a trademark of Goldberg. © 2021 FEI, all rights reserved.



rev1121