

# ACR51W



34" x 23.5" x 21.88" (H x W x D)

Built-In healthcare all-refrigerator with self-closing door, front lock, digital controls, and external temperature readout

### Highlights:

Designed and constructed for reliable cold storage in healthcare facilities

Self-closing door protects interior products from ambient temperatures

External temperature readout of the current and high/low temperatures

### Product Features:

EQTemp Medical Refrigerator	All-refrigerator designed to operate between 2 and 8°C for a variety of storage application in medical offices and other healthcare facilities
Temperature Range: 2° to 8°C	Preset to 5°C as recommended for many storage applications
External temperature readout	Includes continuous display of the current interior and high/low temperature, and can be switched from Celsius to Fahrenheit at the touch of a button
Built-In capable	Front-breathing design lets you make the best use of space by installing your appliance under the counter
High/low temperature alarm	Audible alarm sounds if the interior temperature rises or falls out of set range
Buffered temperature probe	Thermometer probe is encased in a glass bead-filled bottle and stored in a fixed box on the center shelf. This is the ideal way to produce temperature readings closest to stored contents, as recommended by the CDC, VFC and VFA's guidelines
Access port	3/8" probe hole with cover is pre-installed in unit's side to allow easy installation of user-provided monitoring equipment
Factory installed lock	Keyed lock for a secure interior (2 keys included)
Automatic defrost	Reduced user maintenance with automatic defrost

## ACR51W Specifications:

Overview	
Nominal Height	34.0" (86 cm)
Height of Cabinet	34.0" (86 cm)
Nominal Width	24.0" (61 cm)
Width	23.5" (60 cm)
Width with Door Open	23.75" (60 cm)
Nominal Depth	22.0" (56 cm)
Depth	21.88" (56 cm)
Depth with door at 90°	43.63" (111 cm)
Capacity	3.88 cu.ft. (110 L)
Defrost Type	Automatic
Door	White
Cabinet	White
US Electrical Safety	ETL
Canadian Electrical Safety	ETL-C
Amps	2.0
Voltage/Frequency	115 V AC/60 Hz
Weight	81.6 lbs. (37 kg)
Parts & Labor Warranty	1 Year
Compressor Warranty	5 Years
UPC	761101082943
Refrigerator Features	
Door Swing	RHD
Reversible	Factory Reversible
Shelf Type	Wire
Shelf Qty	3
Adjustable Shelves	Yes
Thermostat Type	Digital
Fan Type	Interior
Refrigerant Type	R600a
Refrigerant Amount	1.23oz.
High Side PSI	1.45
Low Side PSI	0.8
Level Legs Qty	2
Interior Light	Yes
Temperature Range	2° to 8°C
Sound Level	40.9 dB
Dimensions	

Interior Height	25.88" (66 cm)
Interior Width	18.75" (48 cm)
Interior Depth	16.5" (42 cm)
Compressor Step Height	4.0" (10 cm)
Compressor Step Width	18.75" (48 cm)
Compressor Step Depth	11.5" (29 cm)

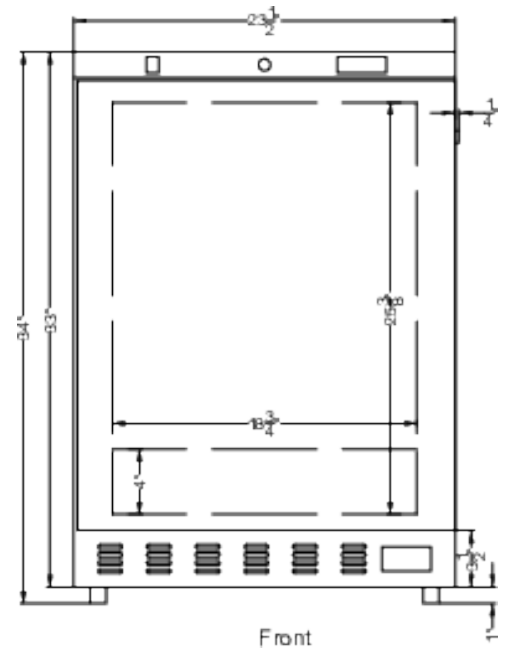
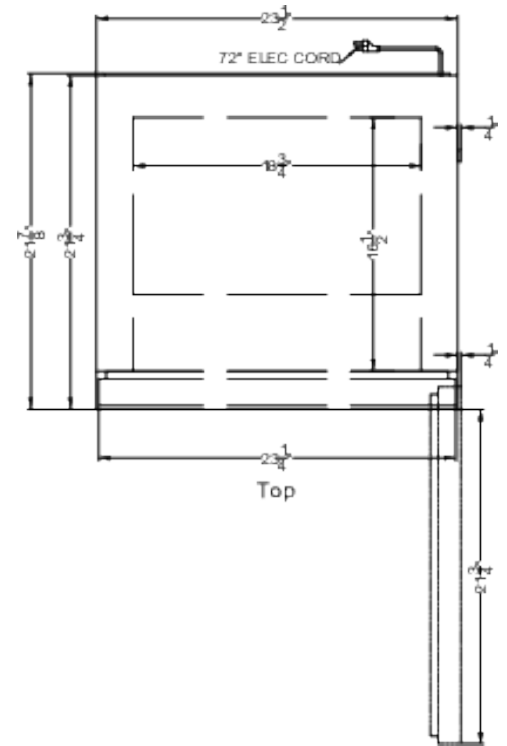

# ACR51WLHD



34" x 23.5" x 21.88" (H x W x D)

Undercounter healthcare all-refrigerator with self-closing door, front lock, digital controls, and external temperature readout

## Highlights:

Designed and constructed for reliable cold storage in healthcare facilities

Self-closing door protects interior products from ambient temperatures

External temperature readout of the current and high/low temperatures

## Product Features:

EQTemp Medical Refrigerator	All-refrigerator designed to operate between 2 and 8°C for a variety of storage application in medical offices and other healthcare facilities
Temperature Range: 2° to 8°C	Preset to 5°C as recommended for many storage applications
External temperature readout	Includes continuous display of the current interior and high/low temperature, and can be switched from Celsius to Fahrenheit at the touch of a button
Built-In capable	Front-breathing design lets you make the best use of space by installing your appliance under the counter
High/low temperature alarm	Audible alarm sounds if the interior temperature rises or falls out of set range
Buffered temperature probe	Thermometer probe is encased in a glass bead-filled bottle and stored in a fixed box on the center shelf. This is the ideal way to produce temperature readings closest to stored contents, as recommended by the CDC, VFC and VFA's guidelines
Access port	3/8" probe hole with cover is pre-installed in unit's side to allow easy installation of user-provided monitoring equipment
Factory installed lock	Keyed lock for a secure interior (2 keys included)
Automatic defrost	Reduced user maintenance with automatic defrost

## ACR51WLHD Specifications:

Overview	
Nominal Height	34.0" (86 cm)
Height of Cabinet	34.0" (86 cm)
Nominal Width	24.0" (61 cm)
Width	23.5" (60 cm)
Width with Door Open	23.75" (60 cm)
Nominal Depth	22.0" (56 cm)
Depth	21.88" (56 cm)
Depth with door at 90°	43.63" (111 cm)
Capacity	3.88 cu.ft. (110 L)
Defrost Type	Automatic
Door	White
Cabinet	White
US Electrical Safety	ETL
Canadian Electrical Safety	ETL-C
Amps	2.0
Voltage/Frequency	115 V AC/60 Hz
Weight	81.6 lbs. (37 kg)
Parts & Labor Warranty	1 Year
Compressor Warranty	5 Years
UPC	761101107554
Refrigerator Features	
Door Swing	LHD
Reversible	Factory Reversible
Shelf Type	Wire
Shelf Qty	3
Adjustable Shelves	Yes
Thermostat Type	Digital
Fan Type	Interior
Refrigerant Type	R600a
Refrigerant Amount	1.23oz.
High Side PSI	1.45
Low Side PSI	0.8
Level Legs Qty	2
Interior Light	Yes
Temperature Range	2° to 8°C
Sound Level	40.9 dB
Dimensions	

Interior Height	25.88" (66 cm)
Interior Width	18.75" (48 cm)
Interior Depth	16.5" (42 cm)
Compressor Step Height	4.0" (10 cm)
Compressor Step Width	18.75" (48 cm)
Compressor Step Depth	11.5" (29 cm)

