

ACR1012GNSF456



53.13" x 23.33" x 28.38" (H x W x D)

Upright healthcare all-refrigerator certified to NSF/ANSI 456 with self-closing glass door, front lock, digital controls, and NIST-calibrated temperature readout

Highlights:

Specially designed to meet current CDC/VFC/VFA vaccine refrigeration guidelines for convenient storage in pharmacies, medical offices, and other healthcare facilities

Certified to NSF/ANSI 456 Vaccine Storage Standard

Designed and constructed for reliable cold storage in healthcare facilities

Product Features:

EQTemp Medical Refrigerator	All-refrigerator designed to operate between 2 and 8°C for a variety of storage application in medical offices and other healthcare facilities
Certified to NSF/ANSI 456 Vaccine Storage Standard	Tested to comply with the latest standards
Certificate of calibration included	The temperature monitoring device (TMD) is calibrated to NIST standards in our ISO/IEC 17025:2017 certified calibration laboratory and ships with a 2-year certificate of calibration for your records
Large capacity	Complete 9.88 cu.ft. capacity inside conveniently slim footprint
Temperature Range: 2° to 8°C	Preset to 5°C as recommended for many storage applications
Buffered temperature probe	Thermometer probe is encased in a glass bead-filled bottle and stored in a fixed box on the center shelf. This is the ideal way to produce temperature readings closest to stored contents, as recommended by the CDC, VFC and VFA's guidelines
High/low temperature alarm	Audible alarm sounds if the interior temperature rises or falls out of set range
External temperature readout	Includes continuous display of the current interior and high/low temperature, and can be switched from Celsius to Fahrenheit at the touch of a button

ACR1012GNSF456 Specifications:

Overview	
Nominal Height	54.0" (137 cm)
Height of Cabinet	53.13" (135 cm)
Nominal Width	24.0" (61 cm)
Width	23.33" (59 cm)
Width with Door Open	23.88" (61 cm)
Nominal Depth	29.0" (74 cm)
Depth	28.38" (72 cm)
Depth with door at 90°	50.25" (128 cm)
Capacity	9.88 cu.ft. (280 L)
Defrost Type	Automatic
Door	Glass
Cabinet	White
US Electrical Safety	ETL
Canadian Electrical Safety	ETL-C
Sanitation	ETL-S to NSF 456
Amps	2.0
Voltage/Frequency	115 V AC/60 Hz
Weight	143.3 lbs. (65 kg)
Parts & Labor Warranty	1 Year
Compressor Warranty	5 Years
UPC	761101083162
Refrigerator Features	
Door Swing	RHD
Reversible	Factory Reversible
Shelf Type	Wire
Shelf Qty	4
Adjustable Shelves	Yes
Thermostat Type	Digital
Fan Type	Interior
Refrigerant Type	R600a
Refrigerant Amount	55.0oz.
High Side PSI	0.85
Low Side PSI	1.45
Level Legs Qty	2
Interior Light	Yes
Temperature Range	2° to 8°C
Sound Level	37.2 dB

Dimensions	
Interior Height	44.63" (113 cm)
Interior Width	20.0" (51 cm)
Interior Depth	21.5" (55 cm)
Compressor Step Height	9.0" (23 cm)
Compressor Step Width	20.0" (51 cm)
Compressor Step Depth	8.0" (20 cm)

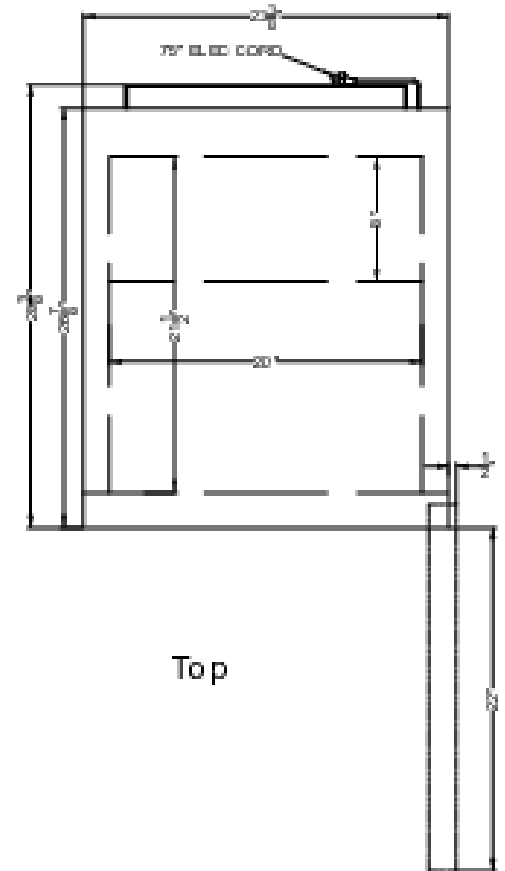

Top

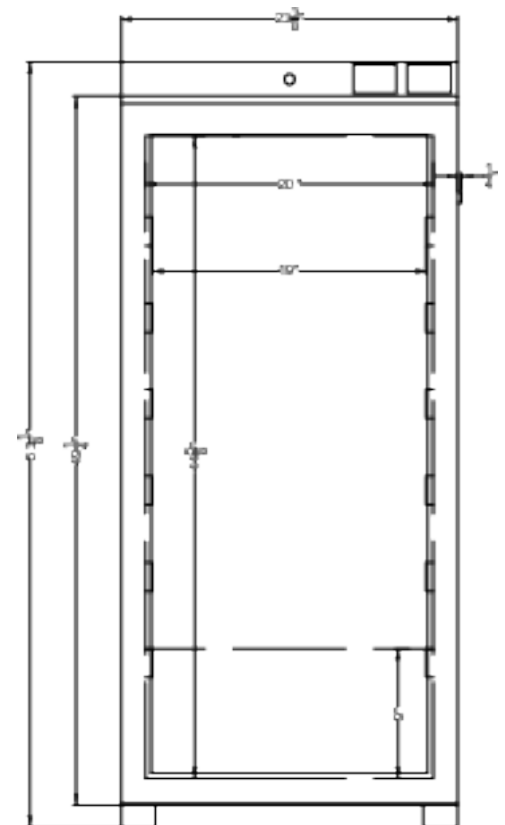

Front

ACR1012GNSF456LHD



53.13" x 23.33" x 28.38" (H x W x D)

Upright healthcare all-refrigerator certified to NSF/ANSI 456 with self-closing glass door, front lock, digital controls, and NIST-calibrated temperature readout

Highlights:

Specially designed to meet current CDC/VFC/VFA vaccine refrigeration guidelines for convenient storage in pharmacies, medical offices, and other healthcare facilities

Certified to NSF/ANSI 456 Vaccine Storage Standard

Designed and constructed for reliable cold storage in healthcare facilities

Product Features:

EQTemp Medical Refrigerator	All-refrigerator designed to operate between 2 and 8°C for a variety of storage application in medical offices and other healthcare facilities
Certified to NSF/ANSI 456 Vaccine Storage Standard	Tested to comply with the latest standards
Certificate of calibration included	The temperature monitoring device (TMD) is calibrated to NIST standards in our ISO/IEC 17025:2017 certified calibration laboratory and ships with a 2-year certificate of calibration for your records
Temperature Range: 2° to 8°C	Preset to 5°C as recommended for many storage applications
Large capacity	Complete 9.88 cu.ft. capacity inside conveniently slim footprint
External temperature readout	Includes continuous display of the current interior and high/low temperature, and can be switched from Celsius to Fahrenheit at the touch of a button
High/low temperature alarm	Audible alarm sounds if the interior temperature rises or falls out of set range
Buffered temperature probe	Thermometer probe is encased in a glass bead-filled bottle and stored in a fixed box on the center shelf. This is the ideal way to produce temperature readings closest to stored contents, as recommended by the CDC, VFC and VFA's guidelines

ACR1012GNSF456LHD Specifications:

Overview	
Nominal Height	54.0" (137 cm)
Height of Cabinet	53.13" (135 cm)
Nominal Width	24.0" (61 cm)
Width	23.33" (59 cm)
Width with Door Open	23.88" (61 cm)
Nominal Depth	29.0" (74 cm)
Depth	28.38" (72 cm)
Depth with door at 90°	50.25" (128 cm)
Capacity	9.88 cu.ft. (280 L)
Defrost Type	Automatic
Door	Glass
Cabinet	White
US Electrical Safety	ETL
Canadian Electrical Safety	ETL-C
Sanitation	ETL-S to NSF 456
Amps	2.0
Voltage/Frequency	115 V AC/60 Hz
Weight	143.3 lbs. (65 kg)
Parts & Labor Warranty	1 Year
Compressor Warranty	5 Years
UPC	761101107776
Refrigerator Features	
Door Swing	LHD
Reversible	Factory Reversible
Shelf Type	Wire
Shelf Qty	4
Adjustable Shelves	Yes
Thermostat Type	Digital
Fan Type	Interior
Refrigerant Type	R600a
Refrigerant Amount	55.0oz.
High Side PSI	0.85
Low Side PSI	1.45
Level Legs Qty	2
Interior Light	Yes
Temperature Range	2° to 8°C
Sound Level	37.2 dB

Dimensions	
Interior Height	44.63" (113 cm)
Interior Width	20.0" (51 cm)
Interior Depth	21.5" (55 cm)
Compressor Step Height	9.0" (23 cm)
Compressor Step Width	20.0" (51 cm)
Compressor Step Depth	8.0" (20 cm)

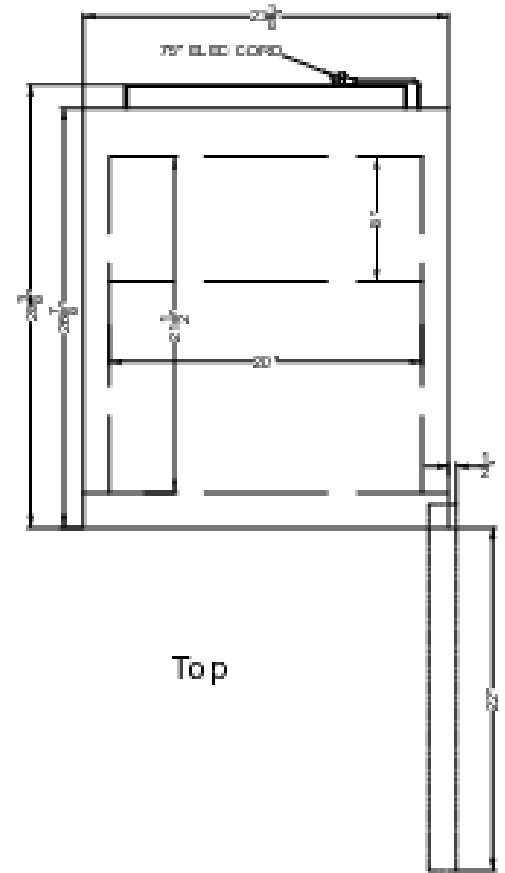

Top

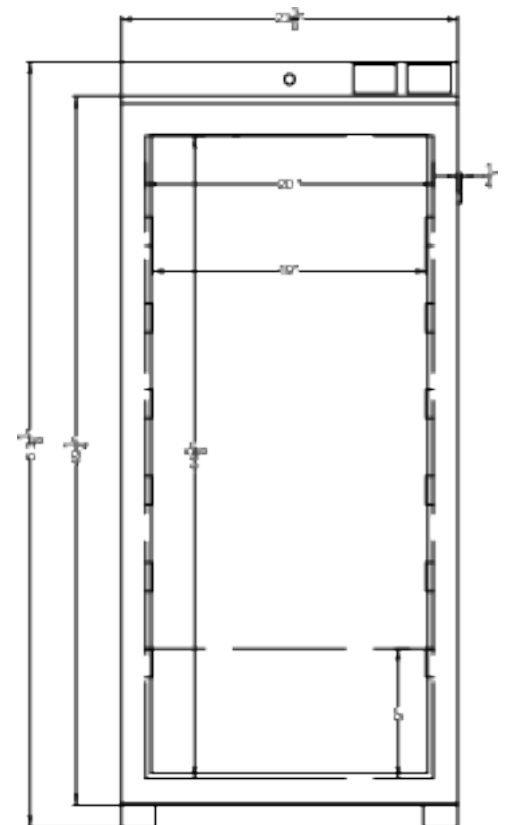

Front