

ACR1012G



53.13" x 23.38" x 28.38" (H x W x D)

Upright healthcare all-refrigerator with self-closing glass door, front lock, digital controls, and external temperature readout

Highlights:

Designed and constructed for reliable cold storage in healthcare facilities

Factory installed lock provides security you can count on

Self-closing door protects interior products from ambient temperatures

Product Features:

EQTemp Medical Refrigerator	All-refrigerator designed to operate between 2 and 8°C for a variety of storage application in medical offices and other healthcare facilities
Temperature Range: 2° to 8°C	Preset to 5°C as recommended for many storage applications
Large capacity	Complete 9.88 cu.ft. capacity inside conveniently slim footprint
External temperature readout	Includes continuous display of the current interior and high/low temperature, and can be switched from Celsius to Fahrenheit at the touch of a button
High/low temperature alarm	Audible alarm sounds if the interior temperature rises or falls out of set range
Buffered temperature probe	Thermometer probe is encased in a glass bead-filled bottle and stored in a fixed box on the center shelf. This is the ideal way to produce temperature readings closest to stored contents, as recommended by the CDC, VFC and VFA's guidelines
Access port	3/8" probe hole with cover is pre-installed in unit's side to allow easy installation of user-provided monitoring equipment
Commercial design	Meets UL-471 commercial standards
Factory installed lock	Keyed lock for a secure interior (2 keys included)

ACR1012G Specifications:

Overview	
Nominal Height	54.0" (137 cm)
Height of Cabinet	53.13" (135 cm)
Nominal Width	24.0" (61 cm)
Width	23.38" (59 cm)
Width with Door Open	23.88" (61 cm)
Nominal Depth	29.0" (74 cm)
Depth	28.38" (72 cm)
Depth with door at 90°	50.25" (128 cm)
Capacity	9.88 cu.ft. (280 L)
Defrost Type	Automatic
Door	Glass
Cabinet	White
US Electrical Safety	ETL
Canadian Electrical Safety	ETL-C
Amps	2.0
Voltage/Frequency	115 V AC/60 Hz
Weight	143.3 lbs. (65 kg)
Parts & Labor Warranty	1 Year
Compressor Warranty	5 Years
UPC	761101083025
Refrigerator Features	
Door Swing	RHD
Reversible	Factory Reversible
Shelf Type	Wire
Shelf Qty	4
Adjustable Shelves	Yes
Thermostat Type	Digital
Fan Type	Interior
Refrigerant Type	R600a
Refrigerant Amount	55.0oz.
High Side PSI	0.85
Low Side PSI	1.45
Level Legs Qty	2
Interior Light	Yes
Temperature Range	2° to 8°C
Sound Level	37.2 dB
Dimensions	

Interior Height	44.63" (113 cm)
Interior Width	20.0" (51 cm)
Interior Depth	21.5" (55 cm)
Compressor Step Height	9.0" (23 cm)
Compressor Step Width	20.0" (51 cm)
Compressor Step Depth	8.0" (20 cm)

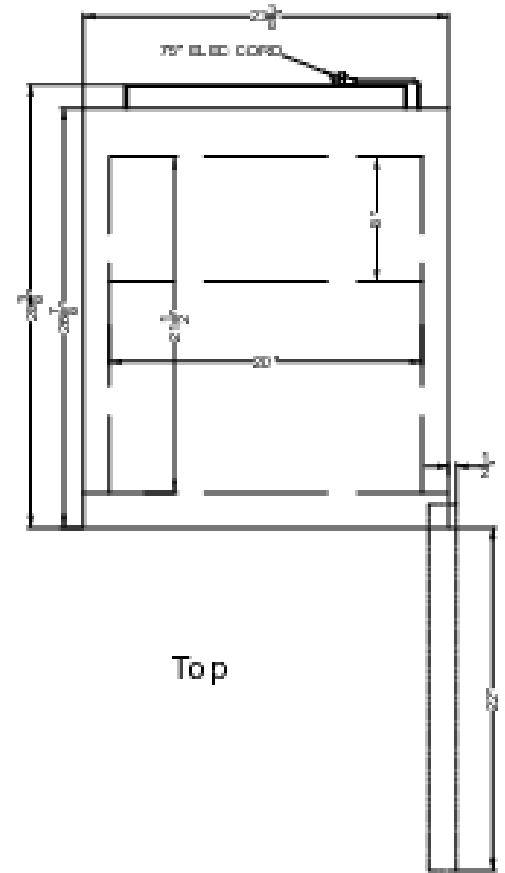

Top

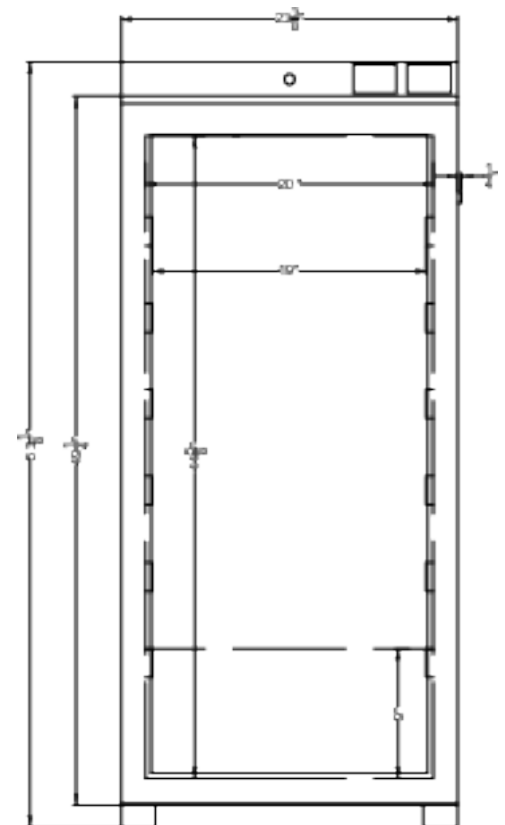

Front

ACR1012GLHD



53.13" x 23.38" x 28.33" (H x W x D)

Upright healthcare all-refrigerator with self-closing glass door, front lock, digital controls, and external temperature readout

Highlights:

External temperature readout of the current and high/low temperatures

User-friendly front control panel keeps the thermostat and alarm in reach without having to open the door

Self-closing door protects interior products from ambient temperatures

Product Features:

EQTemp Medical Refrigerator	All-refrigerator designed to operate between 2 and 8°C for a variety of storage application in medical offices and other healthcare facilities
Temperature Range: 2° to 8°C	Preset to 5°C as recommended for many storage applications
External temperature readout	Includes continuous display of the current interior and high/low temperature, and can be switched from Celsius to Fahrenheit at the touch of a button
Large capacity	Complete 9.88 cu.ft. capacity inside conveniently slim footprint
High/low temperature alarm	Audible alarm sounds if the interior temperature rises or falls out of set range
Buffered temperature probe	Thermometer probe is encased in a glass bead-filled bottle and stored in a fixed box on the center shelf. This is the ideal way to produce temperature readings closest to stored contents, as recommended by the CDC, VFC and VFA's guidelines
Access port	3/8" probe hole with cover is pre-installed in unit's side to allow easy installation of user-provided monitoring equipment
Factory installed lock	Keyed lock for a secure interior (2 keys included)
Automatic defrost	Reduced user maintenance with automatic defrost

ACR1012GLHD Specifications:

Overview	
Nominal Height	54.0" (137 cm)
Height of Cabinet	53.13" (135 cm)
Nominal Width	24.0" (61 cm)
Width	23.38" (59 cm)
Width with Door Open	23.88" (61 cm)
Nominal Depth	29.0" (74 cm)
Depth	28.33" (72 cm)
Depth with door at 90°	50.25" (128 cm)
Capacity	9.88 cu.ft. (280 L)
Defrost Type	Automatic
Door	Glass
Cabinet	White
US Electrical Safety	ETL
Canadian Electrical Safety	ETL-C
Amps	2.0
Voltage/Frequency	115 V AC/60 Hz
Weight	143.3 lbs. (65 kg)
Parts & Labor Warranty	1 Year
Compressor Warranty	5 Years
UPC	761101107639
Refrigerator Features	
Door Swing	LHD
Reversible	Factory Reversible
Shelf Type	Wire
Shelf Qty	4
Adjustable Shelves	Yes
Thermostat Type	Digital
Fan Type	Interior
Refrigerant Type	R600a
Refrigerant Amount	55.0oz.
High Side PSI	0.85
Low Side PSI	1.45
Level Legs Qty	2
Interior Light	Yes
Temperature Range	2° to 8°C
Sound Level	37.2 dB
Dimensions	

Interior Height	44.63" (113 cm)
Interior Width	20.0" (51 cm)
Interior Depth	21.5" (55 cm)
Compressor Step Height	9.0" (23 cm)
Compressor Step Width	20.0" (51 cm)
Compressor Step Depth	8.0" (20 cm)

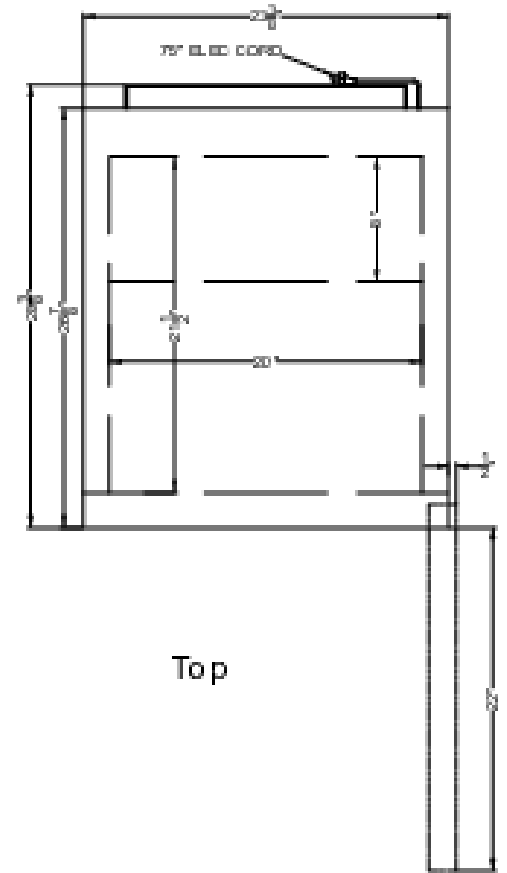

Top

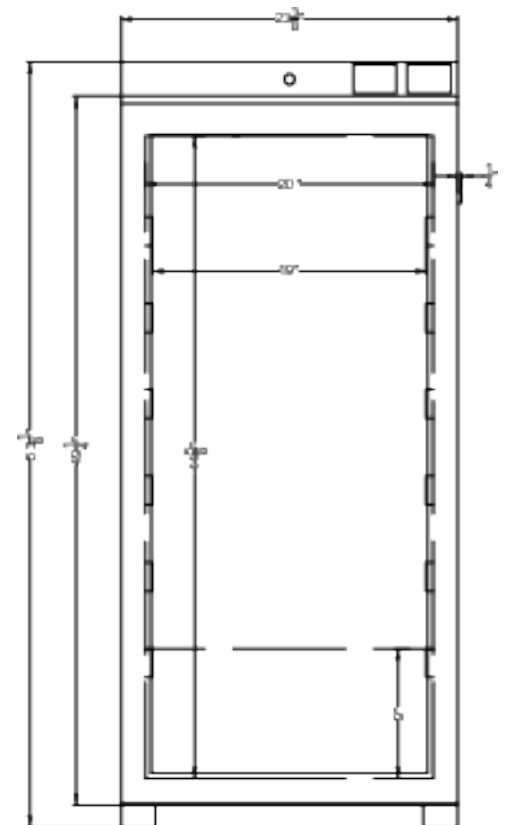

Front