

SO-LOW



ENVIRONMENTAL
EQUIPMENT COMPANY



DH REFRIGERATOR INSTRUCTIONS

USER MANUAL

WARNING: READ BEFORE CONTINUING

To reduce the risk of fire, electric shock or injury to persons using this freezer, read all instructions and follow basic safety precautions before using the unit, including the following:



Do not modify the plug provided with the unit. If it will not fit the outlet, have a proper outlet installed by a qualified electrician.



Do not position equipment so it is difficult to disconnect from the power supply.



While under warranty, do not attempt to repair or replace any part of the freezer for servicing without first contacting the Service Department.



BEFORE CALLING THE MANUFACTURER'S TECHNICAL SUPPORT DEPARTMENT
Please have the model number of the unit, box identification number, and serial number ready as well as the problem description. The model, serial number and box id number can be found on the serial tag, which is located on the interior left upper wall, or back of the unit.

SAVE THESE INSTRUCTIONS

For customer service:

Email: sales@so-low.com

For parts replacement:

Email: parts@so-low.com

For technical support:

Email: service@so-low.com

SHELF INSTALLATION

1. Determine the proper location for the shelf clips. The reference numbers on the pilaster can serve as a guide to ensure all clips are properly located.
2. Insert the top tab of the shelf clip into the desired hole of the pilaster. The retaining tab **MUST** be facing up as shown.
3. Rotate the clip downwards and insert the bottom tab into the matching hole in the pilaster. The clip may need to be squeezed slightly during installation.
4. Install all remaining clips.
5. Install shelves onto clips with the product retention bar facing up. Be careful not to dislodge clips during installation.
6. Place shelves so that the retaining tab on the clip captures the shelf as shown.
7. Confirm that the shelf is resting on **ALL** 4 clips and that the clips are securely attached to the pilasters.
8. Improper shelf clip installation could cause the shelf and / or the product on it to fall, resulting in damage to the unit and possible bodily injury.
9. Do **NOT** overload the shelves. The unit is designed to use all shelves that are supplied in an equally spaced manner.

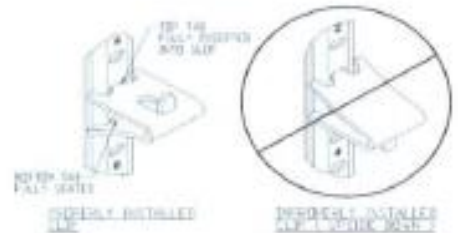
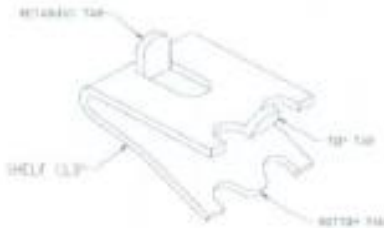

PROPERLY INSTALLED CLIPS

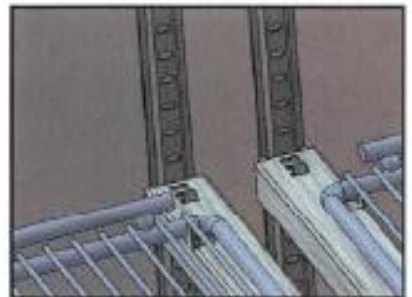
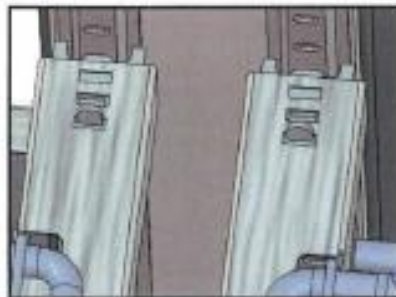

CONTENTS

◆ CLEARANCE & PLACEMENT INSTRUCTIONS.....	1
● PRE-INSTALLATION INFORMATION.....	1
◆ STARTING THE UNIT.....	2
● MOISTURE DURING THE SUMMER SEASON.....	2
◆ GENERAL SPECIFICATIONS.....	3
● OPERATIONAL TEMPERATURE RANGE.....	3
● ELECTRICAL SPECIFICATIONS.....	3
● REFRIGERATION SPECIFICATIONS.....	4
◆ PREVENTATIVE MAINTENANCE.....	5
● CLEANING AND DEFROST PROCEDURE.....	5
● CLEANING THE CONDENSER.....	6
◆ TEMPERATURE CONTROL	7
● CONTROL PROGRAMMING.....	8
● HOW TO CALIBRATE THE CONTROL.....	9
◆ DOOR REVERSAL AND GASKET REPLACEMENT	10
● MONITOR PROBE FOR FIELD INSTALLATION.....	10
● DOOR HINGE ASSEMBLY ILLUSTRATION.....	11
◆ HOW TO ADJUST THE DOOR SPRING (SGD UNITS).....	12
◆ CONTROL SETTINGS	13
● BASIC CONTROL SETTINGS.....	13
● ADVANCED SETTINGS.....	13
◆ FOR THE TRAINED SERVICE TECHNICIAN ONLY.....	14
● THE HIDDEN MENU.....	14
● FOR THE SERVICE TECHNICIAN R290.....	15
◆ WIRE DIAGRAM REFRIGERATOR.....	16
● REFRIGERATOR REVISION 3-1-2016	17
● REFRIGERATOR REVISION 2-1-2013 TO 2-29-2016.....	18
◆ WIRE DIAGRAM FREEZER.....	19
● FREEZER REVISION 3-1-2016	20
● FREEZER REVISION 2-1-2013 TO 2-29-2016.....	21

CLEARANCE AND PLACEMENT INSTRUCTIONS

PRE-INSTALLATION INFORMATION

RANGE OF ENVIRONMENTAL CONDITIONS FOR WHICH THIS EQUIPMENT IS DESIGNED

- Climatic Class 4 (30°C, HR%=55%)
- Ambient temperature operating range: 10°C~40°C
- Humidity: 40% maximum, non-condensing.
- Electrical Supply: 110~127V/60Hz
- Altitude: 300 Meters MSL (Mean Sea Level)
- Usage: This product is intended for use indoors only

PLEASE READ ALL REQUIREMENTS BEFORE USING THIS EQUIPMENT

- 1) **Ambient Temperature** - Unlike a household refrigerator, this equipment is designed for scientific / medical application. Many components are heavy duty and extra sized, to meet the ultimate temperature performance. Therefore, the sounds generated from its operation may not be accepted by everyone in the room. Please take the operations sound factor into consideration and locate this refrigerator accordingly. Please ensure the ambient temperature is climate controlled between 65°F to 80°F to achieve the ultimate temperature performance.
- 2) **Placement** - Find a suitable location to install this refrigerator (or freezer). Must have at least;
 - 6 inches of clearance at the top.
 - 3 inches of clearance at the rear.
 - 0 inches of clearance on all remaining sides.
 - **** PASS-THRU Units require 12" of clearance at the top of the unit ****
- 3) **Floor Load** - The floor on which the unit is located must be even and level, free from vibrations, and strong enough to support the combined weights of the unit and maximum product load.
- 4) **Ventilation** - Grille area at front must be free and clear of any object or wall.
- 5) **Power Outlet** - Dedicated power outlet is located within the length of the unit's power cord. This is a cord-connected unit and must be connected to its own dedicated power supply. Check the data plate on the unit to confirm the voltage and per the data plate use the correct fuses or HACR circuit breakers.
- 6) **Power Cord** - This 115-volt model is equipped with a cord and 5-15P plug. Unit pre-wired at factory and include 8' long cord and plug set. If the power cord becomes damaged, it must be replaced with the identical cord. This Unit Must Be Grounded.



CAUTION

DO NOT CONNECT TO GFI / GFCI OUTLETS. CONNECTION TO THAT TYPE OF OUTLET CAN RESULT IN PRODUCT LOSS DUE TO UNSAFE CABINET TEMPERATURE WHEN GFI DEVICE TRIPS FROM MOISTURE.

DO NOT USE EXTENSION CORDS AND DO NOT DISABLE OR BY-PASS GROUND PRONG ON ELECTRICAL PLUG

STARTING INSTRUCTIONS

1. Move the unit to an indoor location and plug the unit into an appropriate outlet with an adequate power supply. Consult your maintenance department for additional information on the proper electrical configuration for this unit.
2. Once plugged in, the compressor(s) will start to operate and pull down to the setpoint on the temperature control. (Factory setpoint is 4°C Refrigerator, -25°C Freezer)
3. Allow the unit to reach the setpoint temperature.
Depending on the size of the unit, this may take up to 1-2 hours.
4. Product can now be loaded into the unit for storage.

RELEASE OF LIABILITY

IF THIS EQUIPMENT IS BEING USED TO STORE IRREPLACEABLE AND / OR HIGH VALUE PRODUCTS, YOU (THE USER) MUST TAKE PROPER PRECAUTIONS TO ENSURE THAT PRODUCT IS NOT LOST.

SO-LOW WILL NOT BE ACCOUNTABLE FOR, CONSENT TO HAVE OBLIGATION TO, OR INHERIT RESPONSIBILITY OF PRODUCTS STORED INSIDE THE FREEZER / REFRIGERATOR REGARDLESS OF WARRANTY STATUS. THIS PERTAINS TO ANY DIRECT OR INDIRECT LOSSES (PHYSICAL OR ECONOMIC). PLEASE CONSULT THE WARRANTY OF THIS PRODUCT FOR ADDITIONAL CLARIFICATION.

Before this Refrigerator / Freezer can be placed into operation, complete all of the applicable tasks listed below. You may need to consult your own departments for additional assistance with these tasks.

- 1) Connect your company remote alarm contacts system, or auto dialer, to the refrigerator's alarm system. If your model does not have an alarm system, you can install your 3rd party alarm into our refrigerator 1/2" access porthole.
- 2) Develop an emergency backup plan, and designate a separate back-up refrigerator, freezer, or similar appropriate device to store your product, if this equipment has an unforeseen issue.

MOISTURE DURING THE SUMMER SEASON

Due to the increase in ambient humidity in most locations during the summer season; the amount of moisture, condensation, or high humidity related issues may increase during this period.

Please note that in most cases, seasonal humidity related issues will resolve on their own when the ambient humidity levels around the unit reach under 40%.

Also, please note that the refrigeration system does not generate moisture; but instead condenses the moisture that is already in the chamber from the humidity in the air.

To prevent excess seasonal humidity related issues, please see the following;

- 1) Keeping the unit in an air conditioned, low humidity space.
- 2) Check that the door gasket is sealing properly and limit the frequency of door openings.
- 3) Make sure there is a water trap (u-shaped loop) in the drain tube near the end. (This clear tube is in the back of the unit and loops down to the drain pan behind the compressor) This will "trap" a small amount of water in the loop and prevent air from entering the chamber through the tube.

GENERAL SPECIFICATIONS

OPERATIONAL TEMPERATURE RANGE

REFRIGERATOR : 2°C TO 8°C / 36°F to 46°F

FREEZER : -18°C to -20°C, -25°C / 0°F to -13°F

ELECTRICAL SPECIFICATIONS

VOLTAGE	AMPERAGE	PLUG
<p>115 VOLTS 60 HERTZ 1 PHASE</p> <p>(SUPPLY VOLTAGE SHOULD NOT VARY MORE THAN 5% FROM SERIAL PLATE RATINGS.)</p>	<p>15 AMP DEDICATED LINE</p>	 <p>NEMA 5-15 UNIT IS PRE-WIRED AT FACTORY INCLUDES 8' CORD INCLUDES PLUG SET</p>

APPLIES TO MODELS

DH4-8GD DH4-12GD DH4-15GD DH4-23GD DH4-23SD DH4-27GD DH4-27SD DH4-30GD DH4-30SGD DH4-38SGD DH4-45SGD DH4-49GD DH4-49SD DH4-66SGD DH4-74GD DH4-74SD	DH4-23GDSS DH4-23SDSS DH4-27GDSS DH4-27SDSS DH4-49GDSS DH4-49SDSS DH4-72GDSS DH4-72SDSS	DH4-25PT DH4-50PT DH4-80PT
---	--	----------------------------------



ELECTRICAL PLUG

- PLUG THE UNIT INTO THE PROPER OUTLET WITH AN ADEQUATE POWER SUPPLY.
- THIS UNIT REQUIRES A DEDICATED ELECTRICAL LINE.
- UNIT PRE-WIRED AT FACTORY AND INCLUDE 8' LONG CORD AND PLUG SET.

GENERAL SPECIFICATIONS

REFRIGERATION SPECIFICATIONS

MODEL	ENERGY STAR RATED	KWH/DAY	AMPS / HP / BTU/HR	REFRIGERANT
DH4-8GD	☆	2.12	1.15 A / 1/8 HP	R600A – 1.59OZ.
DH4-12GD	☆	2.39	4.1 A / 1/6 HP	R290 – 1.94 OZ.
DH4-15GD	☆	1.82	7.0 A / 1/3 HP	R290 – 2.29 OZ.
DH4-23GD DH4-23SD DH4-23GDSS DH4-23SDSS	☆	2.04	3.0 A / 1/4 HP / 1480 BTU/HR	R290 – 2.12 OZ.
DH4-27GD DH4-27SD DH4-27GDSS DH4-27SDSS	☆	2.05	3.0 A / 1/4 HP / 1480 BTU/HR	R290 – 2.12 OZ.
DH4-38SGD			5.4 A / 1/3 HP / 2392 BTU/HR	R290 – 3.0 OZ.
DH4-45SGD	☆	3.38	5.4 A / 1/3 HP / 2392 BTU/HR	R290 – 3.0 OZ.
DH4-49GD DH4-49SD DH4-49GDSS DH4-49SDSS	☆	3.21	5.4 A / 1/3 HP / 2392 BTU/HR	R290 – 3.0 OZ.
DH4-66SGD	☆	4.42	6.2 A / 1/2 HP / 2808 BTU/HR	R290 – 3.2 OZ.
DH4-72GD DH4-72SD DH4-72GDSS DH4-72SDSS	☆	3.92	6.2 A / 1/2 HP / 2808 BTU/HR	R290 – 3.2 OZ.
DH4-25PT			6.5 A / 1/3 HP / 2800 BTU/HR	R290 – 5.3 OZ.
DH4-50PT			8.5 A / 3/4 HP / 4950 BTU/HR	R290 – 5.3 OZ.
DH4-80PT			10.8 A / 1/3HP (2) /8400 BTU/HR	R290 – 5.3 OZ.

*SPECIFICATIONS SUBJECT TO CHANGE WITHOUT NOTICE

MAINTENANCE PROCEDURES

BEFORE PERFORMING MAINTENANCE

To reduce the risk of fire, electric shock or injury to persons using this unit, read all instructions and follow basic safety precautions.



CAUTION

DISCONNECT THIS UNIT FROM THE POWER SUPPLY
BEFORE PERFORMING MAINTENANCE ON THE UNIT.

CLEANING PROCEDURE

- Wipe down the exterior of the unit with a soft cloth and spray type polish.
- If excessive ice builds up in the evaporator, the unit can be defrosted (see below).

DEFROST PROCEDURE

1. Remove any product in the unit and store it in a back-up unit or elsewhere.
2. Unplug the unit and open the front door.
3. The evaporator drain pan will catch the water that drips from the evaporator and funnel it to the drain pan. (The drain pan may overflow depending on the amount of ice buildup.)
4. Air out the unit for 8-12 hours, allowing the unit to reach room temperature.
5. Take a rag and wipe up all the excess water in the unit.
6. After the defrost plug your unit back in.
7. Once the desired temperature is reached, add product back into the unit.

CLEANING THE CONDENSER

CLEANING AIR CONDENSER

Large amounts of dust build-up on the air-cooled condenser can cause excess stress for the refrigeration system. This excess stress may increase the chance of a refrigeration issue and reduce the life expectancy of the refrigeration system.



ATTENTION

IT IS RECOMMENDED TO CLEAN THE CONDENSER AT LEAST ONCE EVERY 120 DAYS TO PREVENT DUST BUILDUP.

1. Using a Philips Head screwdriver, remove the screw(s) for grill located on front of unit. Once the screws are removed, the front grill can be removed allowing easy access to the air-cooled condenser.

Note: It is recommended to keep the screw(s) in a safe location, so they can be used to re-attach the grill once cleaning is completed.

2. Use a vacuum cleaner to pull up any dust built up on the condenser fins. The most efficient method of doing this is using a furniture cleaning attachment (if available).

Note: Cans of compressed air can also be used to blow away dust, however this is not the most recommended way to clean the condenser as the dust may float through the air and eventually return to clog up the condenser.

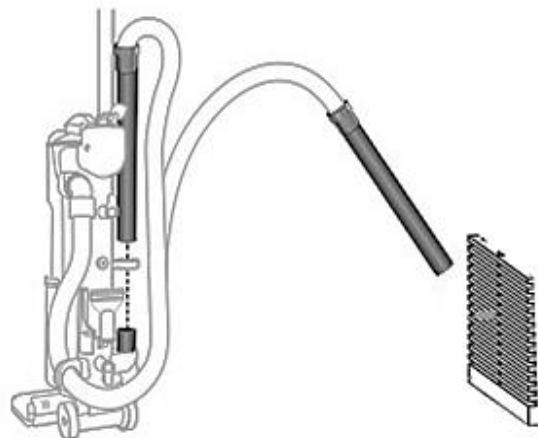

3. Once clean, re-align the front grill and attach it using a screwdriver.

TEMPERATURE CONTROL



EACH LED FUNCTION IS DESCRIBED IN THE FOLLOWING TABLE

LED	MODE	FUNCTION
	ON	Compressor enabled
	Flashing	Anti-short cycle delay enabled
	ON	Defrost enabled
	Flashing	Drip time in progress
	ON	Fans enabled
	Flashing	Fans delay after defrost in progress.
	ON	An alarm is occurring
	ON	Continuous cycle is running
	ON	Energy saving enabled
°C/°F	ON	Measurement unit
°C/°F	Flashing	Programming phase

ALARM SIGNALS / OTHER MESSAGES

MESSAGE	CAUSE
P1	Glycol probe failure
P2	Air probe failure
P4	Evaporator probe failure
HA	Maximum temperature alarm
LA	Minimum temperature alarm
dA	Door open
Pon	Keyboard unlocked
PoF	Keyboard locked



CONTROL PROGRAMMING

CONTROL ADJUSTMENTS



HOW TO CHANGE UNITS FROM °C to °F

1. Press and hold the  key to change units from °C to °F.

HOW TO SEE THE MINIMUM (MIN) TEMPERATURE

1. Press and release the (DOWN)  key.
2. The “Lo” message will be displayed followed by the minimum temperature recorded.
3. By pressing the (DOWN)  key again or by waiting 5s the normal display will be restored.

HOW TO SEE THE MAXIMUM (MAX) TEMPERATURE

1. Press and release the (UP)  key.
2. The “Hi” message will be displayed followed by the maximum temperature recorded.
3. By pressing the (UP)  key again or by waiting 5s the normal display will be restored.

HOW TO RESET THE MAX AND MIN TEMPERATURE RECORDED



1. Hold press the **SET** key for more than 3 seconds, while the max. or min temperature is displayed.
2. To confirm the operation, the “rSt” message starts blinking and the normal temperature will be displayed.

MAIN FUNCTIONS

HOW TO VIEW THE SETPOINT

1. Push and immediately release the **SET** key: the display will show the Set point value.
2. Push and immediately release the **SET** key or wait for 5 seconds to display the probe value again.

HOW TO CHANGE THE SETPOINT





1. Push the SET key for more than 2 seconds to change the Set point value.
2. The value of the set point will be displayed and the “°C” or “°F” LED starts blinking.
3. To change the Set value push the (UP)  or (DOWN)  arrows within 10s.
4. To memorize the new set point value push the **SET** key again or wait 10s.

HOW TO START A MANUAL DEFROST

1. Push the (DEFROST)  key for more than 2 seconds and a manual defrost will start.

HOW TO CHANGE A PARAMETER VALUE

To change the parameter's value, operate as follows:



1. Enter the Programming mode by pressing the Set + (DOWN)  keys for 3s (the “C” or “F” LED starts blinking).
2. Select the required parameter. Press the **SET** key to display its value
3. Use (UP)  or (DOWN)  arrows to change its value.
4. Press **SET** to store the new value. Once **SET** is pressed the display will move to the next parameter.
5. To exit, press **SET** + (UP) , or wait 15 seconds without pressing a key.

NOTE: The set value is stored even when the procedure is automatically exited by time-out.

LOCKING / UNLOCKING KEYBOARD

1. To lock the keyboard, hold down both the (UP)  or (DOWN)  arrows for more than 3 seconds.
2. The “POF” message will be displayed, and the keyboard will be locked.

NOTE: At this point it will be possible only to see the set point or the MAX or MIN temperature stored.

3. If a key is pressed more than 3s the “POF” message will be displayed.
4. To unlock the keyboard, hold down both the (UP)  or (DOWN)  until the “Pon” is displayed.

CONTROL CALIBRATION PROCEDURE

DIXELL SENSOR CALIBRATION FOR SCIENTIFIC AND LAB REFRIGERATORS AND FREEZERS

All units are calibrated at the factory during the testing process. However, the equipment should be re-calibrated in the field once the unit has been in place and running. Calibration is a simple and quick process which does not require any refrigeration experience. Any in-house personnel with basic knowledge of the electronic controller is able to perform the re-calibration. Please follow the below procedure for assistance in completing the calibration process.

- To accomplish calibration, you will need a calibrated thermometer of your own.
- Place an additional thermometer as close as possible to the glycol bottle in the cabinet.
- Let the unit run for about 15-20 minutes with the door closed.

1. While waiting for 15-20 minutes, verify the set point of the cabinet by pressing the **SET** key once. When you do this, the controller will display the running temperature that has been selected.

If you decide to change the setpoint temperature, hold the **SET** key down until the °C symbol begins flashing. Once flashing, let go of the **SET** key and use the (**UP**) ▲ or (**DOWN**) ▼ arrows to modify the setpoint to your desired temperature.

2. Press the **SET** key once to save your change and the entire display will flash confirming your change. Nothing more is required, and the display will return to showing internal temperature condition summarily. If the set point is changed, however, the unit will have to run for a period of time to stabilize.

3. To begin calibration procedure:

- Check the set point by pressing **SET** key.
- Confirm the temperature showing on the thermometer you placed near the glycol bottle inside the cabinet is within an acceptable range* of the temperature showing on the control.

*Note; your company will be responsible for defining what is an “acceptable range”.

***** IF THERE IS NO DIFFERENCE IN TEMPERATURE, DO NOT PROCEED FURTHER *****

4. If there is a significant difference between your thermometer and the control, follow the below instructions below to re-calibrate your equipment to the correct temperature:

- Press and hold both the (**DOWN**) ▼ arrow and **SET** keys until **LOD** appears.
- Release the keys.
- Press and hold both the (**DOWN**) ▼ arrow and **SET** keys until **PR2** appears and starts flashing.
- Release the (**DOWN**) ▼ arrow and **SET** keys. **HY** will appear on the display.
- Press and release the (**UP**) ▲ arrow three times; or until you get to setting **Ot**.
- Press the **SET** key to access the **Ot** setting (temperature control sensor calibration).
Input the difference between your thermometer and the set point temperature into this screen.
Press and release the (**UP**) ▲ or (**DOWN**) ▼ arrows to adjust the value to the desired value.
 - If the unit is too warm inside, put a positive number in **Ot**.
 - If the unit is too cold inside, put a negative number in **Ot**
- Press and release the **SET** key to save your changes.
The entire display will flash confirming your change.

The calibration procedure is now complete.

This correction will make the unit run at the desired set point.

DOOR REVERSAL AND GASKET REPLACEMENT

DOOR REVERSAL INSTRUCTIONS

To reverse-hinge the door on your equipment, please follow the following procedure.



WARNING

Before performing any adjustments or modifications, ensure that the door is secured, wrapped, or protected in some way to prevent damage during this process. This is particularly necessary for glass doors. You may wish to have additional personnel assist you with this process.

1. Remove the hinge cover.
2. Remove the door from the unit, including the hinge mounting brackets.
3. On the side you would like the hinges to be located, remove all white hole plugs from the side of the door opening on the unit (**Do not throw these white hole covers away**).
4. On the bottom of the door remove the white hole plugs.
5. Use the removed hole plugs from step 3, and insert them into the screw holes where the hinges were originally located on the unit.
6. Install the hinge bracket upright on the unit.
Note: The thick portion of the hinge bracket should be on the bottom as you mount them.
7. The door portion of the hinges need to be removed and rotated 180 degree and remounted.
8. In the holes where the first handle was previously mounted, install the hole plugs which were removed from the bottom of the door in step 4.
9. Slide the door back into position and gently lower into the white pivot cam, and then re-attach the removed hinge cover.

DOOR GASKET REPLACEMENT

1. Remove existing gasket from mounting track.
2. Verify mounting track is free of any remaining gasket material.
3. Align new gasket with mounting track and press firmly in place.
4. Open and close door, checking for proper gasket seal without pinching against refrigerator.

MONITOR PROBE FOR FIELD INSTALLATION

Each refrigerator or freezer is equipped with a 1/2" probe access port hole for your independent probe installation. The port hole is generally located in the back of your refrigerator or freezer. Simply remove the black cap, run your probe through, and seal the hole with black cap, or electrical putty to prevent air from getting into chamber.

DO NOT RUN YOUR PROBE THROUGH THE DOOR GASKET

Doing so, may cause serious condensation or frozen evaporator issue.

The port hole is specifically designed to allow you to install the monitor probe.

This refrigerator or freezer is factory set to run at its ultimate temperature performance. There should be no need to adjust the temp settings. If you feel the temp settings must be adjusted, please refer to temperature adjustment section in the manual for details.

DOOR HINGE ASSEMBLY ILLUSTRATION

HINGE TO DOOR, AND DOOR TO CABINET ASSEMBLY INSTRUCTIONS

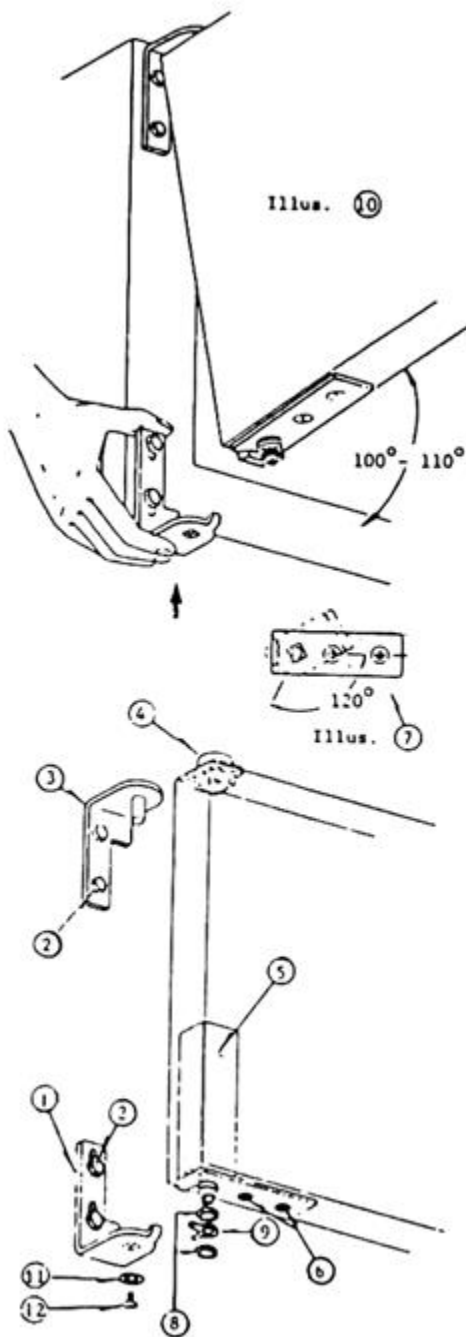

- A. Place lower bracket (1) in position on cabinet, and loosely fasten with 1/4" hex head bolts (2). **Brackets must be allowed to move up with hand pressure.**
- B. Place upper bracket (3) in position on cabinet, and tightly fasten with 1/4" hex head bolts (2).
- C. Push nylon pivot bushing (4) into the square opening at the door top.
- D. Insert cartridge assembly (5) into square opening on bottom of door, and secure with #10 countersunk screws, (6).
- E. Using the square opening of an extra bottom bracket, or a wrench, rotate the square head of the cartridge shaft approximately **120°** in closing direction of the door. Hinge is now pre-loaded and ready to be secure to door bracket (**See Illus. 7.**)
- F. Place nylon washer (8), stop spring (9) and second washer (8) over cartridge shaft. Tape to door and secure during mounting of the door. Spring (9), should have tabs facing the front of the door.
- G. Hold door in a **100°** position from the cabinet face, as shown in **Illus. 10**. Proceed to place the upper corner over the protruding bracket pin. Insert square shaft of cartridge into square opening of the bottom bracket.
- H. Proceed to insert bottom retaining screw (11). Fasten securely... Door can now be closed and will function properly.

HOW TO ADJUST THE DOOR SPRING (SGD UNITS)

DOOR SPRING ADJUSTMENT (SGD UNITS)

ADJUSTING SPRING TENSION

The amount of tension used on the self-closing slider doors can be decreased or increased by relocating the spring retaining grommet and self-drilling screw.

1. Hold door in open position to expose spring, grommet, and screw in the header. Open only as far as required to keep the amount of tension to a minimum.
2. Look into Header and note the 3 square cut outs.

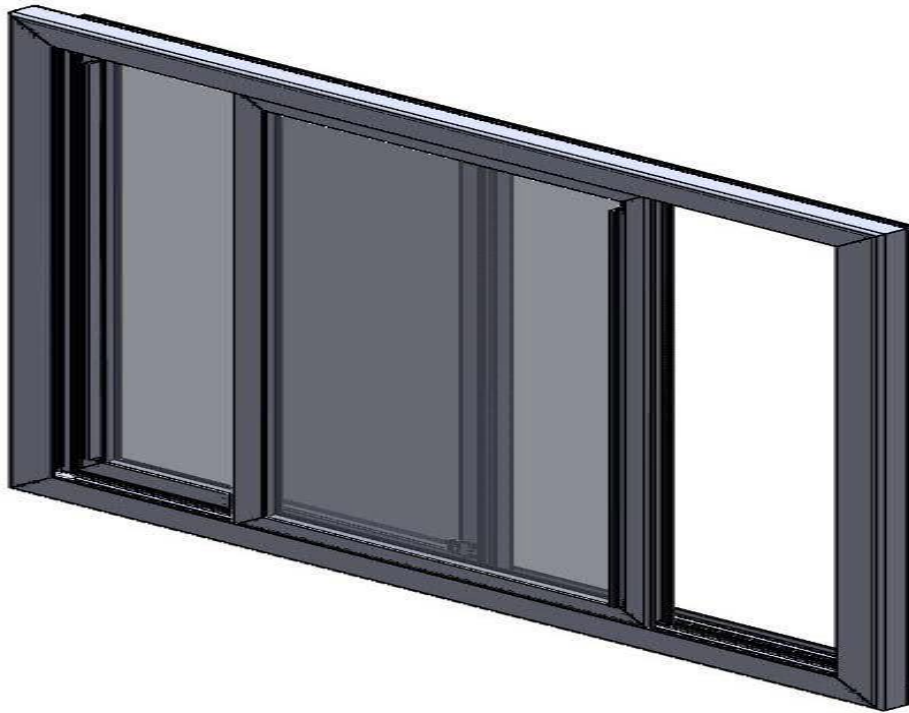

1. Inner location is for minimum tension.
2. Mid location is for mid-range tension.
3. Outside location is for maximum tension.

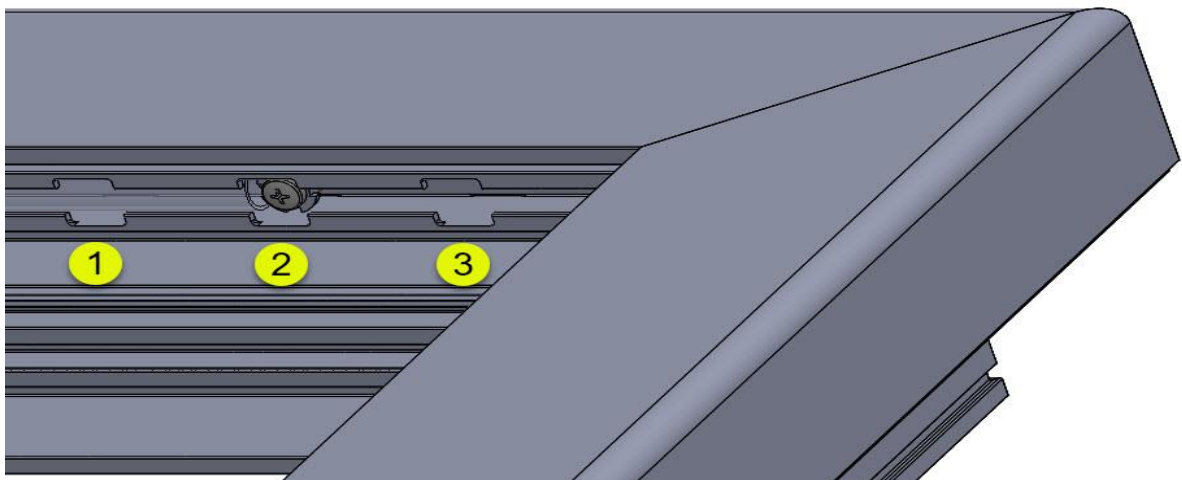

CONTROL SETTINGS

BASIC CONTROL SETTINGS

DESCRIPTION	DEFAULT SETTINGS REFRIGERATOR	DEFAULT SETTINGS FREEZER
FACTORY TEMPERATURE SETPOINT	4°C (38°F)	-25°C (-13°F)
TEMPERATURE ALARM DELAY (SETTING ALD)	5 Min	5 Min
ALARM – DOOR OPEN ALARM DELAY (SETTING did)	5 Min	5 Min
ALARM – HIGH TEMPERATURE (SETTING ALU)	10°C (50°F)	-10°C (14°F)
ALARM – LOW TEMPERATURE (SETTING ALL)	1°C (34°F)	-30°C (-22°F)

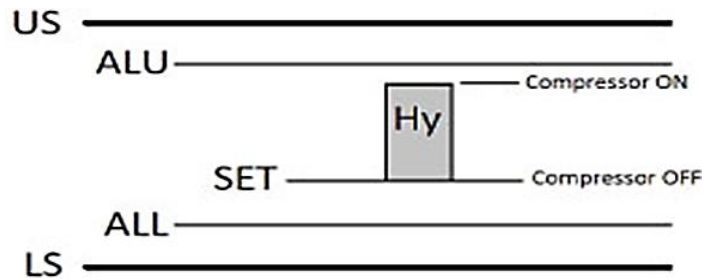

AIR AND GLYCOL TEMPERATURE DISPLAY

The controller has the capability to display either the air or glycol temperature readout. For the normal operations, the Glycol simulated temperature (**P1**) is displayed to provide users the product temperature. For the actual operation, the air temperature (**P2**) is used to control the compressor's cycle.

ADVANCED SETTINGS

ATTN: THIS SECTION IS FOR SERVICE TECHNICIANS OR EXPERIENCED USERS ONLY.

Modification of values or intervals between defrost and or Hysteresis settings can result in malfunction, or inaccurate temperature readouts, and could void your warranty. Proceed at your own risk.

DESCRIPTION	DEFAULT SETTINGS REFRIGERTOR	DEFAULT SETTINGS FREEZER
INTERVALS BETWEEN DEFROST	NONE	6 HOURS
DISPLAY CALIBRATION - (SETTING Ot)	0.0	0.0
HYSTERESIS – (DIFFERENTIAL)	2.0°C (4.0°F)	2.0°C (4.0°F)
MAXIMUM RANGE LIMIT- (SETTING US)	10°C (50°F)	0°C (0°F)
MINIMUM RANGE LIMIT – (SETTING LS)	1°C (34°F)	-25°C (-13°F)

FOR THE TRAINED SERVICE TECHNICIAN



- During the normal operation, the refrigerator's (or freezer's) compressor will cycle on and off, to maintain the cold temperature in the storage chamber.
- During operation of this controller, the point where the compressor is cut off is called "**SET POINT**". The point where the compressor is turned on is calculated by adding the value of "**SET POINT**" and "**Hy**" (temp differential). For example, if you wish to maintain the operation temperature between 2°C and 8°C, you will program **SET** = 4°C, and **Hy** = 2°C. The unit would then run between 4°C and -6°C.
- **ALU** is the high temp alarm point, and **ALL** is the low temp alarm point. Both alarm settings will alert users when the refrigerator's (or freezer's) temp is out of range, via visual & audible alarm, and remote alarm contact.
- **US** is the upper setting limit, and **LS** is the lower setting limit. Both limit settings will prevent users accidentally adjust **SET**, **ALU**, or **ALL** outside the range.

HIDDEN MENU / ADVANCED OPERATIONS





THE HIDDEN MENU INCLUDES ALL THE PARAMETERS OF THE INSTRUMENT
DO NOT CHANGE PARAMETERS IN THE HIDDEN MENU UNLESS INSTRUCTED TO DO SO BY THE SERVICE DEPARTMENT

HOW TO ENTER THE HIDDEN MENU

1. Enter the Programming mode by pressing the **SET + (DOWN)**  arrow keys for 3 seconds.
 - ❖ The °C or °F LED will then start blinking.
2. Released the keys, then push again the **SET + (DOWN)**  arrow keys for more than 7 seconds.
 - ❖ The **Pr2** label will be displayed immediately followed from the **HY** parameter.

NOW YOU ARE IN THE HIDDEN MENU.

3. Select the required parameter.
4. Press and release the **SET** key to display its value.
5. Press and release the **(UP)**  or **(DOWN)**  arrow keys to change its value.
6. Press and release the **SET** key to store the new value and move to the following parameter.

TO EXIT, press **SET + (UP)** , or wait 15 seconds without pressing a key.

NOTE: The set value is stored even when the procedure is automatically exited by time-out.

MOVING HIDDEN PARAMETERS TO USER LEVEL

Each parameter present in the **HIDDEN** menu can be transferred to the **USER** menu ("THE FIRST LEVEL")

- Follow steps 1 and 2 in the paragraph above, to enter the hidden menu.
- Select the required parameter.
- Press and release **SET + (DOWN)**  on the desired parameter.

NOTE: In then **HIDDEN** menu, the decimal point is displayed when a parameter is enabled to show in the **USER** menu.

** FOR SERVICE TECHNICIANS ONLY **



FLAMMABLE REFRIGERANT GAS

RISK OF FIRE OR EXPLOSION. FLAMMABLE REFRIGERANT USED.
ALL SAFETY PRECAUTIONS MUST BE FOLLOWED.
DO NOT PUNCTURE REFRIGERANT TUBING.

REFRIGERATION SERVICE SHOULD ONLY BE ATTEMPTED BY A TRAINED
TRADE PROFESSIONAL CERTIFIED TO WORK ON R290 SYSTEMS.

CRITICAL SERVICE ITEMS ARE LISTED BELOW

THIS LIST IS ONLY A REMINDER AND CHECKLIST FOR THE SERVICE TECH **THIS LIST DOES NOT QUALIFY ANYONE TO SERVICE THE UNIT**

Keep these in mind for **R290 service**:

- ✓ Wire nuts are NOT to be used when changing an electrical part.
- ✓ The switches in this product are sealed. **Only exact replacements may be used.**
- ✓ The process tubes are to be used for service access only.
- ✓ Cut out (with tubing cutter) refrigeration components that are to be replaced. **Do NOT un-braze.**
- ✓ If R290 is to be vented into the air during service, the venting MUST be in an area free from flame or spark. **It must be near an opened window or door.**
- ✓ A sign noting service of a system containing propane must be attached to the unit during refrigeration service.
- ✓ A combustible gas leak detector must be used to inform anyone in the area when propane is present in the air.

Other Information:

Evacuation: It is critical that a refrigeration system be leak free and internally dry. A thorough evacuation with a good vacuum pump with a micron gauge attached is the only way to ensure that the system is dry and ready for a charge of refrigerant.

Charging: The system is critically charged, and the proper type and amount MUST be weighed in.

Overcharge symptoms: Unit will cool properly but the suction line temperature will be unusually cold. Compressor run time will be longer than normal.

Undercharge symptoms: long run time, poor cooling and a hot compressor dome are the main symptoms of an undercharge.

WIRE DIAGRAM - REFRIGERATOR

Refrigerator - Wiring

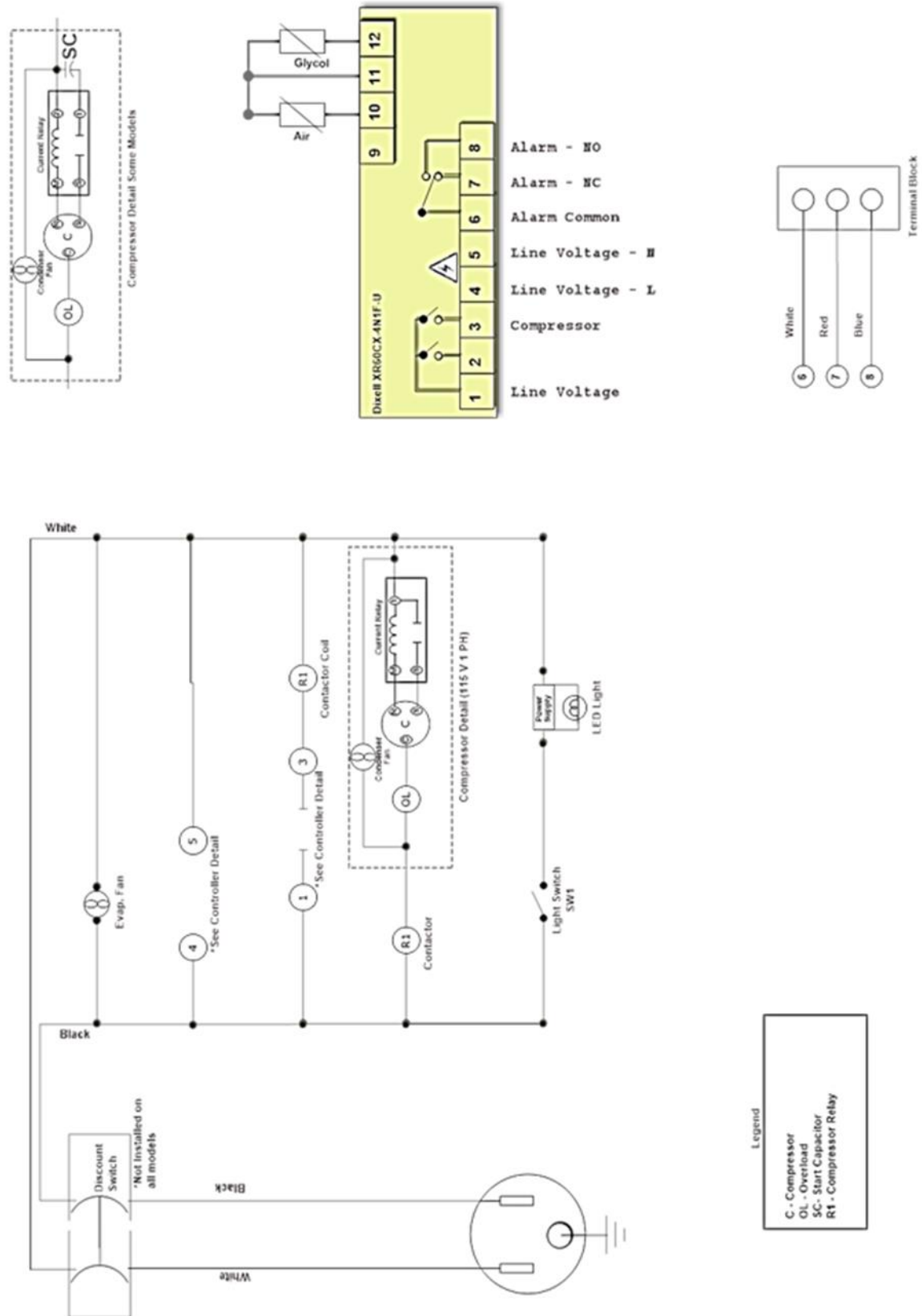

- Legend
- C - Compressor
 - OL - Overload
 - SC - Start Capacitor
 - R1 - Compressor Relay

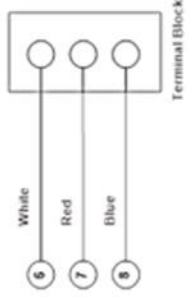
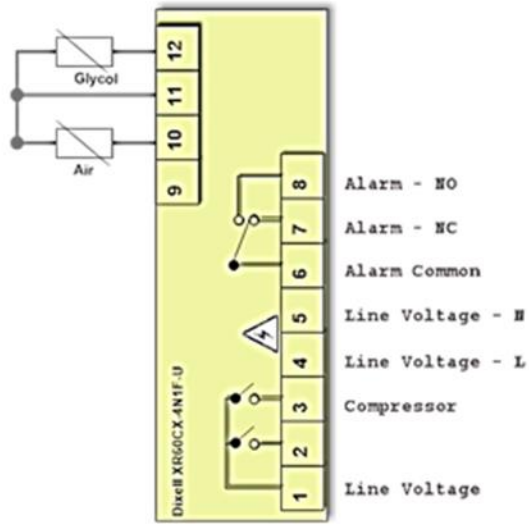
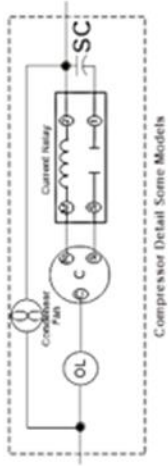

WIRE DIAGRAM - REFRIGERATOR

REFRIGERATOR REVISION 3-1-2016

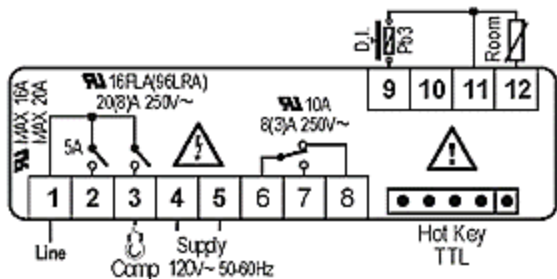

LINE 1 - BLACK (LINE VOLTAGE)

LINE 2-

LINE 3- RED- COMPRESSOR

LINE 4- WHITE- COMMON

LINE 5- BLACK POWER (LINE VOLTAGE)

LINE 6- WHITE ALARM RELAY

LINE 7- RED ALARM RELAY

LINE 8- BLUE ALARM RELAY

LINE 9- DOOR SWITCH - BLUE

LINE 10- AIR TEMPERATURE PROBE (P2)

LINE 11- ONE LEG FROM GLYCOL, AIR PROBE, DOOR SWITCH (BLUE) TIED TOGETHER

LINE 12- GLYCOL BOTTLE PROBE (P1)

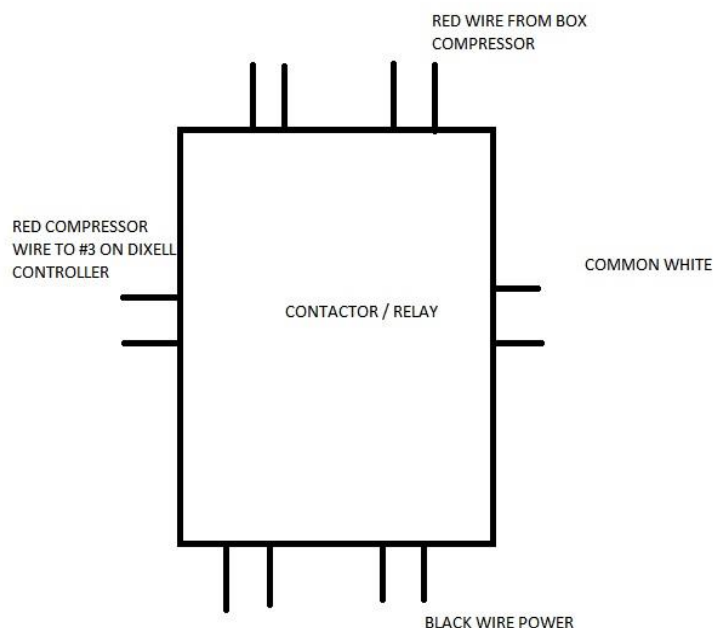

WIRE DIAGRAM - REFRIGERATOR

REFRIGERATOR

2-1-2013-2/29/2016 REV

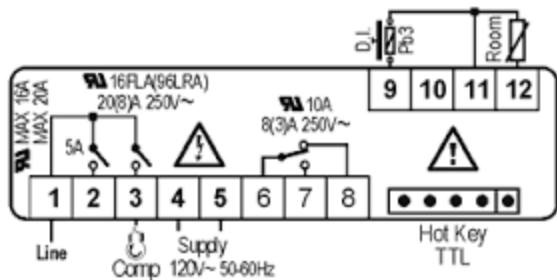

LINE 1 - BLACK (LINE VOLTAGE)

LINE 2- NOT USED

LINE 3- RED- COMPRESSOR

LINE 4- WHITE- COMMON

LINE 5- BLACK POWER (LINE VOLTAGE)

LINE 6- WHITE ALARM RELAY

LINE 7- RED ALARM RELAY

LINE 8- BLUE ALARM RELAY

LINE 9-

LINE 10- GLYCOL BOTTLE PROBE

LINE 11- LINE 10 & LINE 12, TIED TOGETHER

LINE 12- AIR TEMPERATURE PROBE

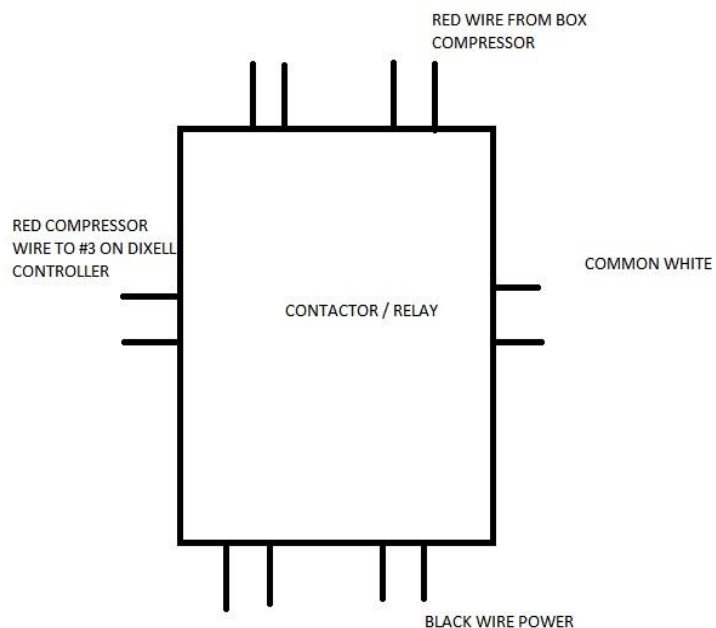

WIRE DIAGRAM- FREEZER

Freezer - Wiring

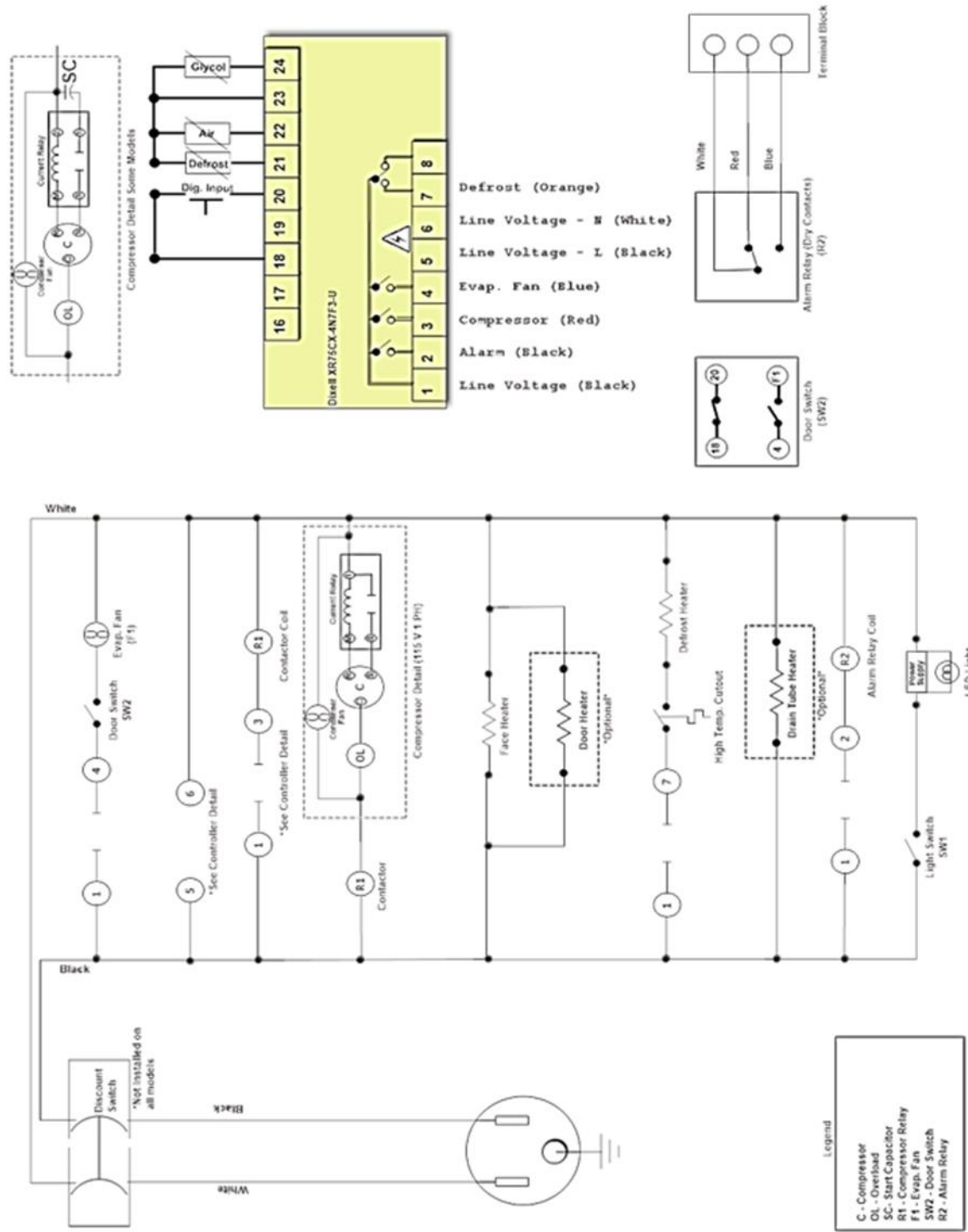

FREEZERS

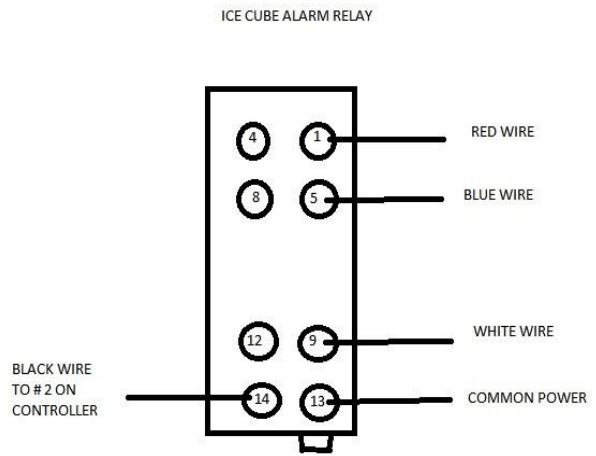
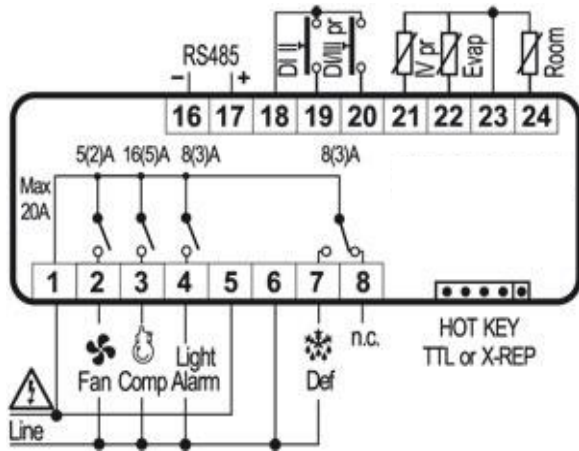

- LINE 1- BLACK (LINE VOLTAGE)
- LINE 2-ALARM OUTPUT TO RELAY- BLACK
- LINE 3- COMPRESSOR- RED/ BROWN
- LINE 4- FAN- BLUE
- LINE 5- LINE VOLTAGE- BLACK
- LINE 6- COMMON- WHITE
- LINE 7- DEFROST- ORANGE
- LINE 18- DOOR SWITCH- BLUE
- LINE 20- DOOR SWITCH- BLUE
- LINE 21- BLACK EVAP PROBE- BLACK (P4)
- LINE 22- AIR PROBE - BLACK (P2)
- LINE 23- COMMON LEG FOR ALL 3 PROBES
- LINE 24- GLYCOL PROBE- BLACK (P1)

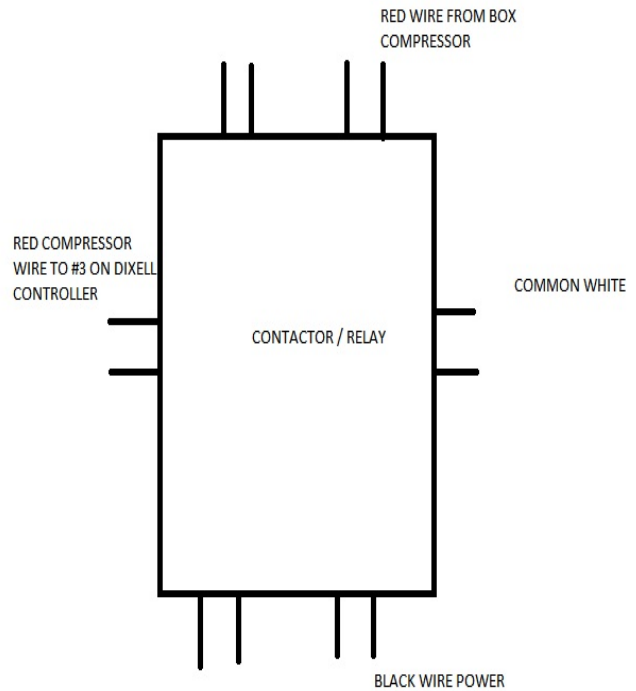

FREEZER CONTINUED

REVISION 2-1-2013 - 2-29-2016

FREEZERS

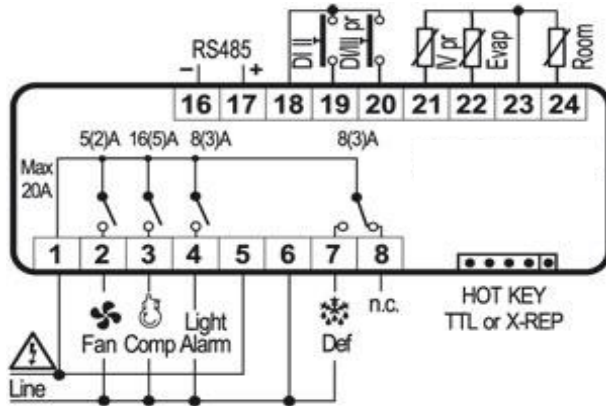

- LINE 1- BLACK (LINE VOLTAGE)
- LINE 2-ALARM OUTPUT TO RELAY- BLACK
- LINE 3- COMPRESSOR- RED/ BROWN
- LINE 4- FAN- BLUE
- LINE 5- LINE VOLTAGE- BLACK
- LINE 6- COMMON- WHITE
- LINE 7- DEFROST- ORANGE
- LINE 18- DOOR SWITCH- BLUE
- LINE 20- DOOR SWITCH- BLUE
- LINE 21- GLYCOL PROBE- BLACK
- LINE 22- EVAP PROBE- BLACK
- LINE 23- COMMON LEG FOR ALL 3 PROBES
- LINE 24- AIR PROBE - BLACK

ICE CUBE ALARM RELAY

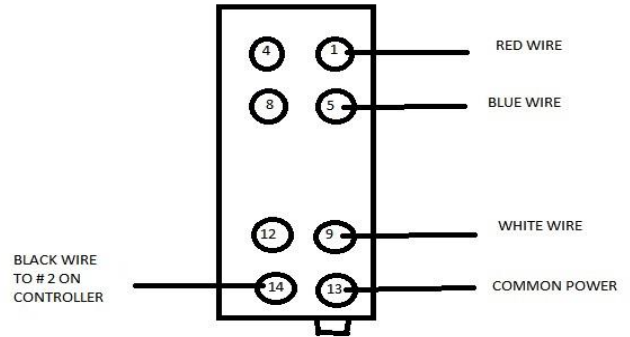

RED WIRE FROM BOX
COMPRESSOR

