



Electrocardiograph & Diagnostic Spirometer

Cardio Q50

Operation Manual



Ver. 1.02

2024. 4. 18



REVISION HISTORY

Revision No.	Date	Contents	Page
1.00	2023.03.30	First Written	All
1.01	2023.12.14	New logo change, Reflects FDA's requirements	All
1.02	2024.04.18	<ul style="list-style-type: none">– Update European Sales email and web address– Change logo– Update customer service information– Typo correction– Add missing information	All

CAUTION

Federal law restricts this device to sale by or on the order of a physician

NOTE

The product does not have shelf life. Its expected use life is 6.5 years. After 6.5 years, though the product still works normally, it is recommended to have it checked by Bionet.

※ In the event of a malfunction or failure, contact Service Dept. Of Bionet Co., Ltd. along with the model name, serial number, date of purchase and explanation of failure.

Paid Services

A fee will be charged for all services except for breakdowns, so be sure to read this operation manual below before putting in a request.

<ul style="list-style-type: none"> - Usage description and simple inspection without disassembly - In case of reinstallation due to poor installation by a distributor 	<p style="text-align: center;">Free the 1st time Charged starting the 2nd time</p>
<ul style="list-style-type: none"> - Inadequate installation or loosening due to physical product movement, relocation, etc. - When re-installing after the first installation requested by the customer at the time of purchase - When reinstallation is required due to inexperienced installation by the customer - When a service is requested due to the input of foreign substances or improper cleaning 	<p style="text-align: center;">Charged starting the 1st time</p>

1. Equipment cleaning, adjustment, and usage description are not product breakdowns.

(Unfeasible repairs are subject to separate standards.)

2. Breakdowns caused by consumer negligence

Breakdowns and damage due to careless handling by the customer or incorrect repair are caused by:

- Using incompatible electric capacity.
- Mishaps such as dropping the product.
- Using the third party replacements or options not specified by our company.
- Non-Bionet technicians or agency technicians in the process of repair.

3. Other cases

- Breakdowns by natural disasters (fire, salt damage, flood damage, earthquake, etc.)
- When a consumable part has reached the end of its life (accessories)

Warnings, Cautions, and Notes

- The following terms are used throughout this manual to emphasize important and critical information. You must read these statements to help ensure safety and to prevent product damage.
- The manufacturer or the product distributor is not liable for any loss or damage to the product caused by incorrect use or negligence in product maintenance.

WARNING

WARNING Failure to follow this message may cause severe injuries, casualty or physical damage to patients.

CAUTION



CAUTION Failure to follow this message may cause in non-life-threatening injury or damage to the equipment.

NOTE

NOTE indicates some important information and tips, which are not dangerous, about installation, operations and maintenance.

General Precautions on Environment

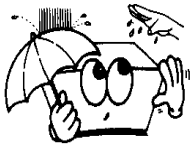
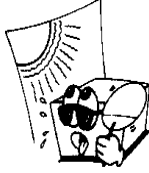
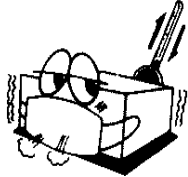
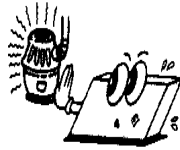
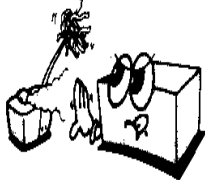
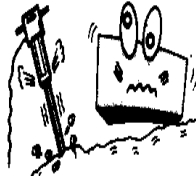
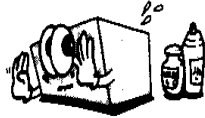
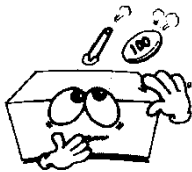
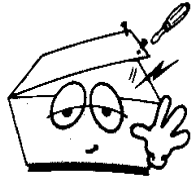
DO NOT store or operate the equipment in the places listed below.

	<p>A place exposed to moisture (DO NOT touch the equipment with wet hands.)</p>		<p>A place under direct sunlight</p>
	<p>A place in areas with highly fluctuating temperatures.</p>		<p>A place in the vicinity of Electric heater</p>
	<p>A place with excessive humidity rise or poor ventilation</p>		<p>A place with sources that cause excessive shock or vibration</p>
	<p>A place exposed to chemicals or at risk of gas leakage</p>		<p>Avoid the invasion of small objects/ particles such as dust, and especially avoid metallic material.</p>
	<p>DO NOT disjoint or disassemble the equipment. (Bionet is not liable for broken products caused by attempted disassembly.)</p>		<p>DO NOT connect power until the product is completely installed. It may cause damage to the product.</p>

Safety Instructions for Electricity

Please note the following precautions before using the product.

- Is the power supply cord proper? (100 - 240V AC)
- Is every cord connected properly to the product?
- Is the product fully grounded? (Otherwise, noise may occur.)
- There is a risk of electric shock if the Rest stand of the equipment is damaged or not be fixed to the equipment body. Do not use the product and immediately ask the manufacturer or seller for repairs.

Classification

- This equipment is classified in accordance with IEC 60601-1 as follows.
- Class I protection against electric shock and Type CF defibrillation-proof
- Compatibility Requirements standard:- Parts
- Degree of protection against harmful ingress of water: Ordinary
- DO NOT use this product near flammable anesthetic or solvents.
- Continuous operation
- IEC/EN 60601-1-2 (Electromagnetic Compatibility Requirements) standard:

Type	Description
Class A	The equipment or system is suitable for use in all establishments. It requires a higher amount of power than the public low-voltage power supplied to typical residential buildings. Mains power should be typical commercial or hospital environment.

NOTE

Diagnosis provided by Cardio Q50 / Cardio Q70 must be confirmed by a qualified medical professional.

NOTE

The EMISSIONS characteristics of this equipment make it suitable for use in industrial areas and hospitals (CISPR 11 class A). If it is used in a residential environment (for which CISPR 11 class B is normally required) this equipment might not offer adequate protection to radio-frequency communication services. The user might need to take mitigation measures, such as relocating or re-orienting the equipment.

CAUTION	
	<p>Warning: MR-unsafe!</p> <p>DO NOT expose the device to a magnetic resonance (MR) environment.</p> <ul style="list-style-type: none">• The device may present a risk of projectile injury due to the presence of ferromagnetic materials that can be attracted by the MR magnet core.• Thermal injury and burns may occur due to the metal components of the device that can heat during MR scanning.• The device may generate artifacts in the MR image. <p>The device may not function properly due to the strong magnetic and radiofrequency fields generated by the MR scanner.</p>

Safety Messages

The following messages are applied throughout the product. Certain statements may also appear elsewhere in the manual.

WARNING:

ACCIDENTAL SPILLS — If the equipment is penetrated with liquid, take it out of service and have it checked by a service technician before using it again.

DO NOT allow liquids to enter the equipment to prevent electric shock or equipment malfunction.

WARNING:

BATTERY OPERATION - If the integrity of the electrical grounding is doubtful, use battery to operate the equipment.

WARNING:

CABLES — To avoid possible strangulation, route all cables away from the patient's throat.

WARNING:

CONNECTION TO MAINS — This is class I equipment.

Connect the mains power plug to an appropriate power supply.

WARNING:

DEFIBRILLATOR PRECAUTIONS - Avoid physical contact with the patient during defibrillation, as it may cause serious injury or death.

Patient signal inputs labeled with the CF symbols with paddles are protected against damage resulting from defibrillation voltages.

The defibrillator paddles in relation to the electrodes should be placed properly to assure successful defibrillation.

Use only recommended cables and leads to ensure adequate defibrillation protection.

WARNING:

ELECTRODES - Polarized electrodes (stainless steel or silver constructed) may cause the electrodes to retain a residual charge after defibrillation. Residual charge blocks ECG signal acquisition.

Use non-polarized electrodes (silver or silver chloride construction) for ECG monitoring with each defibrillation.

WARNING:

MAGNETIC AND ELECTRICAL INTERFERENCE - Magnetic and electric fields may interfere with the proper operation of the equipment.

Therefore, make sure that all external devices operated in the vicinity of the equipment comply with the relevant EMC requirements.

X-ray equipment or MRI devices are possible sources of interference as they may emit higher levels of electromagnetic radiation.

WARNING:

Use of this equipment adjacent to or stacked with other devices should be avoided because it could result in improper operation. If such use is unavoidable, this equipment and other devices should be observed to verify that they are operating normally.

WARNING:

EXPLOSION HAZARD - Do not use this equipment in the presence of anesthetics vapors or liquids.

WARNING:

INTERPRETATION HAZARD — Computerized interpretation is only significant when used in conjunction with clinical findings.

All computer-generated diagnostics are subject to be verified by a qualified physician.

WARNING:

OPERATOR — Medical technical equipment such as this system must be used only by qualified and trained personnel.

WARNING:

SHOCK HAZARD - Improper use of this equipment may cause electric shock.

Strictly observe the following guidelines.

Failure to do so may endanger the lives of the patient, user, and bystanders.

To disconnect the equipment from the power line, first remove the power plug from the wall outlet before disconnecting the cables from the equipment; Otherwise, there is a risk that metal parts inadvertently inserted into the power cord socket will come into contact with line voltage.

Additional devices connected to medical electrical equipment shall comply with the respective IEC or ISO standards (e.g., IEC 60950 for data processing equipment).

Additionally, all configurations must comply with the requirements for medical electrical system. (See IEC 60601-1-2 or Clause 16 of IEC 60601-1)

Anyone who connects additional devices to medical electrical equipment is in the position of configuring medical system, and is responsible for complying with the requirements of medical electrical system.

Keep in mind that local legislation takes precedence over the above-mentioned requirements.

If in doubt, consult your local distributor or the technical service department.

WARNING:

SITE REQUIREMENTS - Improper placement of equipment and/or accessories may result in a hazard to the patient, operator, or bystanders.

DO NOT route cables in a way that they may present a stumbling hazard.

To ensure safety, all connectors on patient cables and lead-wires are designed to prevent inadvertent disconnection, should someone pull on them.

For equipment installed above the patient, take appropriate measures to prevent them from dropping on the patient.

WARNING:

TREADMILLS — Avoid rapid changes in treadmill speed and/or grade during a stress test.

WARNING:

Use of accessories, transducers and cables other than those specified or provided by the manufacturer of this equipment may increase electromagnetic emission or reduce electromagnetic susceptibility, causing it to malfunction.

WARNING:

Portable RF communications equipment - including antenna cables and peripherals such as external antennas - should be used no closer than 30cm (12 inches) to any part of the [ME EQUIPMENT or ME SYSTEM], including the cables specified by the manufacturer.

WARNING:

The equipment is not designed for use with high-frequency (HF) surgical equipment such as electrocautery and diathermy equipment and does not provide any protection against patient risk. In addition, other electronic devices such as RFID emitter can negatively affect signal quality.

CAUTION:

PROPER LEAD-WIRE CONNECTION — Improper connection will cause inaccuracies in the ECG. Trace each individual lead-wire from the acquisition module label to the color-coded connector, then to the appropriate electrode to ensure that it is matched to the correct label location.

CAUTION:

ACCESSORIES (SUPPLIES) - The parts and accessories used must comply with the requirements of the relevant IEC 60601 series safety standards and essential performance standards, and/or the system configuration must meet the requirements of the IEC 60601-1-2 medical electrical system standards.

CAUTION:

ACCESSORIES (EQUIPMENT) - The use of accessory equipment that does not comply with the equivalent safety requirements of this equipment may lead to a reduced level of safety

of the resulting system.

Considerations related to the choice of equipment shall include:

- Use of the accessory in the patient vicinity, and Evidence that the safety certification of the accessory has been performed in accordance with the appropriate IEC 60601–1 and/or IEC IEC 60601-1-2 harmonized national standard.

CAUTION:

BATTERY POWER — If a device equipped with an optional battery pack will not be used or connected to the power line for a period of over six months, remove the battery.

CAUTION:

BEFORE INSTALLATION — Compatibility is critical to safe and effective use of this equipment. Please contact your local sales or service representative prior to installation to verify equipment compatibility.

CAUTION:

DISPOSABLES — Disposable devices are intended for single use only.

They should not be reused as performance may degrade or contamination could occur.

CAUTION:

DISPOSAL — At the end of its service life, the product described in this manual, as well as its accessories, must be disposed of in compliance with local, state, or federal guidelines regulating the disposal of such products. If you have questions concerning the disposal of the product, please contact Bionet or its distributor.

CAUTION:

EQUIPMENT DAMAGE — Equipment intended for emergency application must not be exposed to low temperatures during storage and transport to avoid moisture condensation at the application site. Wait until all moisture has vaporized before using the equipment.

CAUTION:

ELECTRIC SHOCK — To reduce the risk of electric shock, do not remove cover or back of the equipment. Refer servicing to qualified personnel.

CAUTION:

OPERATOR — Medical technical equipment such as this electrocardiograph system must only be used by persons who have received adequate training in the use of such equipment and who are capable of applying it properly.

CAUTION:

POWER REQUIREMENTS — Before connecting the equipment to the power line, check that the voltage and frequency ratings of the power line are the same as those indicated on the label of the equipment. If this is not the case, do not connect the system to the power line until you adjust the equipment to match the power source.

In the USA, if the installation of this equipment will use 240V instead of 120V, the source must be center tapped, 240V single-phase circuit.

This equipment is suitable for connection to public mains as defined in CISPR 11.

Equipment connected to the ECG system and to the patient's environment must be powered from a medically isolated power source or must be a medically isolated equipment. Equipment powered from a non-isolated source can result in chassis leakage currents exceeding safe levels. Chassis leakage current generated by the accessories or equipment connected to a non-isolated outlet may be added to the chassis leakage current of the ECG system.

CAUTION:











SERVICEABLE PARTS — This equipment contains no user serviceable parts.





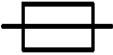





Refer servicing to qualified service personnel.





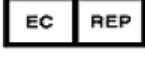

CAUTION:

SUPERVISED USE — This equipment is intended for use under the direct supervision of a licensed health care practitioner.

Safety Symbols

Symbols	Description
	Attention: Consult accompanying documents.
	Consult Instructions for Use: This symbol advises the reader to consult the operating instructions for information needed for the proper use of the equipment.
	Safety Sign: It indicates that you should read the user manual. Read the user manual before starting work or operating the equipment.
	General Prohibition Sign
	Defibrillation Proof-Type CF APPLIED PART
	Type B APPLIED PART
	AC Power
	Fuse
	Conductor provides a connection between equipment and the potential equalization bus bar of the electrical installation
	ECG Patient Cable Connector
	USB Connector

Symbols	Contents	
	Spirometry Connector	
	Local Area Network (LAN) connector	
	Power On / Off	
	Battery Operation Indicator	
	AC Power Connection Indicator	
	Manufacturer	
	Authorized Distributor in the European Community	
	Waste of electrical and electronic equipment must not be disposed as unsorted municipal waste and must be collected separately. Please contact an authorized representative of the manufacturer for information concerning the decommissioning of your equipment.	
	MR Unsafe: DO NOT use this equipment in all MR environment.	
	Non-sterile	 DO NOT use if the package is damaged.

	Single Use Only DO NOT reuse the mouthpiece: it is a single time use only.		Recycling; Dispose of properly in accordance with all state, provincial and national regulations.
	This way up; For the duration of shipping/delivery, the carton should face upright.		Fragile; Handle with care.
	Use no hooks; Absolutely no hand hooks should be attached to pull the parcel.		Keep away from rain.

Specifications or functions described in this user manual are subject to change without notice for product improvement.

Chapter 1. General Rules

1) Product Overview



Cardio Q50 is a 12-channel ECG (Electrocardiogram) recording equipment that measures and records the patient's ECG. It not only provides parameters necessary for diagnosis, patient's ECG record and automatic diagnosis, but also increases chart management efficiency by providing ECG records and printing reports when patient or user information is entered. At the same time, it can transmit the saved data to a PC for file management. Its user-oriented design enables ECG examination with a single push of a button. It saves, transfers and prints the data that has been acquired by automatic diagnosis.

It provides the user with the necessary parameters, which are necessary for patient diagnosis, along with the spirometry record. After spirometry tests, you can print out a report on A4/letter paper together with the spirometer record to efficiently manage the patient's or user's chart. The stored data is forwarded to a PC that is in charge of managing digital files. In addition, the battery pack, which can be stored inside as an optional component, ensures high portability and makes it possible to inspect or use the equipment in an emergency.

1-1) Intended Use(Indications for use)

The Cardio Q50 ECG Analysis System is intended to acquire, analyze, display and record ECG information from adult and pediatric populations.

* Bionet Algorithm - 3 years or older / Glasgow Algorithm - 0 years or older

The system provides 12-lead ECG and interpretive analysis.

The 12-Lead ECG interpretation algorithm provides analytical information about the patient's heart condition, which must be confirmed by a qualified medical professional along with other relevant clinical information.

Sending and receiving ECG data to and from the Hospital Information System is optional. The Cardio Q50 is intended to be used by personnel trained in hospitals or medical professional facilities under the direct supervision of a licensed healthcare practitioner.

In addition, the Cardio Q50 is intended for prescription use only to perform spirometry diagnostic tests in adults and pediatric patients aged 5 and older in general practice, specialist and hospital settings. The device is intended to be used what measures patient respiratory parameters including FVC, FEV1/FEV6, SVC, MVV.

1-2) Indications

The ECG has proven to be among the most useful diagnostic tests in clinical medicine. It is now routine in the evaluation of patients with implanted defibrillators and pacemakers, as well as to detect myocardial injury, ischemia and the presence of prior infarction as well. In addition to its usefulness in ischemic coronary disease, the ECG is of particular use in the diagnosis of disorders of the cardiac rhythm and the evaluation of syncope.

This device is for prescription use only as a spirometer that measures respiratory parameters in patients including FVC, FEV1/FEV6

1-3) Contraindications

No absolute contraindications to performing an electrocardiogram, other than patient refusal, exist. Some patients may have allergies, or more commonly, sensitivities to the adhesive used to affix the leads; in these cases, hypoallergenic alternatives are available from various manufacturers.

Contraindications to spirometry are presented in the "2019 American Thoracic Society (ATS) Standardization of Spirometry" and are listed below. Cardio Q50 / Cardio Q70 applies the list of contraindications below item 1~5.

1. myocardial demand or changes in blood pressure

- Acute myocardial infarction within 1 wk
- Systemic hypotension or severe hypertension
- Significant atrial/ventricular arrhythmia
- Noncompensated heart failure
- Uncontrolled pulmonary hypertension
- Acute cor pulmonale
- Clinically unstable pulmonary embolism
- History of syncope related to forced expiration/cough

2. increases in intracranial/intraocular pressure

-
- Cerebral aneurysm
 - Brain surgery within 4 wk
 - Recent concussion with continuing symptoms
 - Eye surgery within 1 wk
3. increases in sinus and middle ear pressures
- Sinus surgery or middle ear surgery or infection within 1 wk
4. increases in intrathoracic and intraabdominal pressure
- Presence of pneumothorax
 - Thoracic surgery within 4 wk
 - Abdominal surgery within 4 wk
 - Late-term pregnancy
5. Infection control issues
- Active or suspected transmissible respiratory or systemic infection, including tuberculosis

Physical conditions predisposing to transmission of infections, such as hemoptysis, significant secretions, or oral lesions or oral bleeding

1-4) Side Effects

The ECG is a safe test that does not cause health complications. There are no medical conditions associated with increased risk or adverse side effects of ECG.

1-5) Warnings, Cautions and Adverse Reactions

- a. Modifications to this equipment are not allowed. Any unauthorized changes to the Cardio Q50 / Cardio Q70 device may compromise product safety and/or data and as such Cardio Q50 / Cardio Q70 cannot be held responsible and the equipment will no longer be supported.
- b. The Cardio Q50 / Cardio Q70 is not designed as sterile equipment. Always follow the safety instructions given by the manufacturer of cleaning and disinfectant chemicals.
- c. Cardio Q50 / Cardio Q70 intended that Disposable Mouthpiece be used for every subject to prevent cross contamination. Disposable mouthpieces provide a significant degree of protection for the subject, equipment, and user from cross-contamination during spirometry. A mouthpiece is for single use only.
- d. Spirometry is a valuable tool that provides health care providers with important information to consider along with other physical findings, symptoms, and medical history to obtain a

diagnosis.

- e. Do not allow the subjects to block the mouthpiece with their tongue or teeth during the test. A 'spitting' action or cough will give false readings.
- f. Do not expose the Cardio Q50 / Cardio Q70 to liquids.
- g. Do not use Cardio Q50 / Cardio Q70 in the presence of flammable liquids or gases, dust, sand or other chemicals.
- h. All spirometry standards recommend checking the accuracy of the lung function measuring devices with a 3-L syringe daily to validate that the equipment is measuring accurately. The Cardio Q50 / Cardio Q70 should not be outside the accuracy limits. Accuracy should be checked after cleaning or disassembling the spirometer for any reason, after adjusting calibration or if the flow head or device has been dropped.
- i. Service and repairs should only be carried out by the manufacturer or a service agent approved by Cardio Q50 / Cardio Q70.
- j. Do not perform maintenance while the equipment is in use by a subject.
- k. Using accessories or cables that are not specified or provided by the manufacturer of Cardio Q50 / Cardio Q70 may increase electromagnetic emission or reduce electromagnetic susceptibility, causing them to malfunction.
- l. Non-medical equipment must be kept outside the subject environment i.e. any area in which intentional or unintentional contact between the subject and parts of the system, or some other persons touching part of the system, can occur.
- m. Portable RF communications equipment (including peripherals such as antenna cables and external antennas) should be more than 30cm (12 inches) away from any part of the Cardio Q50 / Cardio Q70, including cables specified by the manufacturer. Otherwise, degradation of the performance of this equipment could result.
- n. Use of this equipment adjacent to or stacked with other devices should be avoided because it could result in improper operation. If such use is necessary, this equipment and the other equipment should be observed to verify that they are operating normally.
- o. The mouthpiece is in contact with the subject during spirometry sessions with the Cardio Q50 / Cardio Q60 / Cardio Q70. There are no adverse effects from contact with other parts of the device, including the mouthpiece.
- p. Only use the Cardio Q50 / Cardio Q70 with the power supply provided. Attempted use with other power sources may cause irreparable damage and invalidate the warranty.

2) Recording ECGs during Defibrillation

This equipment is protected against the effects of cardiac defibrillator discharge to ensure

recovery, as required by test standards. The patient signal input of the acquisition module is defibrillation-proof, therefore, it is not necessary to remove the ECG electrodes prior to defibrillation.

When using stainless steel or silver electrodes a defibrillator discharge current may cause the electrodes to retain a residual charge causing a polarization or DC offset voltage.

This electrode polarization will block the acquisition of the ECG signal. To avoid this condition, use non-polarized electrodes, which will not form a DC offset voltage when subjected to a DC current, such as silver/silver-chloride types if there is a situation where there is a likelihood that a defibrillation procedure will be necessary.

If using polarized electrodes, disconnect the lead-wires from the patient before the shock is delivered. Electrode defibrillation recovery is the ability of the electrode to allow the ECG trace to return to normal after defibrillation. It is recommended to use non-polarized disposable electrodes with a Defibrillation Recovery class as specified in AAMI EC12 4.2.2.4. AAMI EC12 requires that the polarization potential of an electrode pair does not exceed 100mV, 5 seconds after a defibrillation discharge.

3) Product Characteristics

- This equipment configures the 12-channel ECG waveforms in various configurations, such as 3 channels + 3 rhythm, 3 channels + 1 rhythm, 6 channels + 1 rhythm, and 12 channels, and prints them on A4 or Letter size paper.
- The rhythm of 1 channel acquired for a certain period of time (1 minute, 3 minutes, 5 minutes, 10 minutes, 20 minutes, or 30 minutes) is printed on A4 or Letter size paper.
- The 12 channel rhythms are continuously printed simultaneously in real time.
- The heart rate, PR interval, RR interval, QRS interval, QT interval, QTc interval, P-R-T axis, and SV1/RV1/R+S size required for diagnosis are automatically calculated and provided on the report along with the ECG.
- Automatic ECG diagnostic results for pediatrics and adults are provided.
- A Disclosure function is provided to save and show ECG data up to 30 minutes. The Disclosure function helps diagnose an arrhythmia.
- Once an ECG is saved, you can change its filter settings, gain, print speed, channel configuration and rhythm settings, and print it out, which is helpful for diagnosis.
- The Z-Folder Printer facilitates paper management.
- You can enter the patient or user information and print it out, which makes chart management efficient.
- Battery can be internally equipped as an optional component, facilitating convenient carry and use.
- You can store up to 500 patient data, and transfer the stored data to another PC over the

network, or save them in a USB memory.

- Various protocols are supported to enable connection with the hospital computer network (EMR, PACS, etc.), and File and Worklist DB functions have been enhanced.
- You can monitor the lung function progress or the result value in real-time basis on the LCD, and the best result is automatically chosen after 3 or 8 tests.
- You can transfer the lung function test result data to a PC for long-term storage, and print it out using a general PC printer.
- All values displayed are expressed as BTPS values.

4) Product Configuration

The Cardio Q50 system consists of the following components. Open the packaging box and check that all components below are included and make sure that the main body or components are not damaged.



Basic configuration and Accessories



① Body (1ea.)

- Cardio Q50 Dimension 286 (W) x 350 (D) x 140 (H) mm
- Cardio Q70 Dimension 286 (W) x 350 (D) x 144 (H) mm

② Patient Cable (1ea.)

No.	Photo	Description
1		Length: 3,350 mm Weight: 0.386 kg Color: Brown Type: Option Code Number: 152600-019011 (EU) 152600-012811 (US)
2		Length: 3,550 mm Weight: 0.425 kg Color: White Type: Standard Code Number: 152600-044400 (EU) 152600-044500 (US)
3		Length: 3,800 mm Weight: 0.437 kg Color: White Type: Option Code Number: 152600-044600 (EU) 152600-044700 (US)

- ③ Disposable electrodes (1 SET)
- ④ ECG clips (1 SET)
- ⑤ ECG Recording Paper (1ea.)
- ⑥ Power Cable (1ea.) - Length 2,500mm (Max)

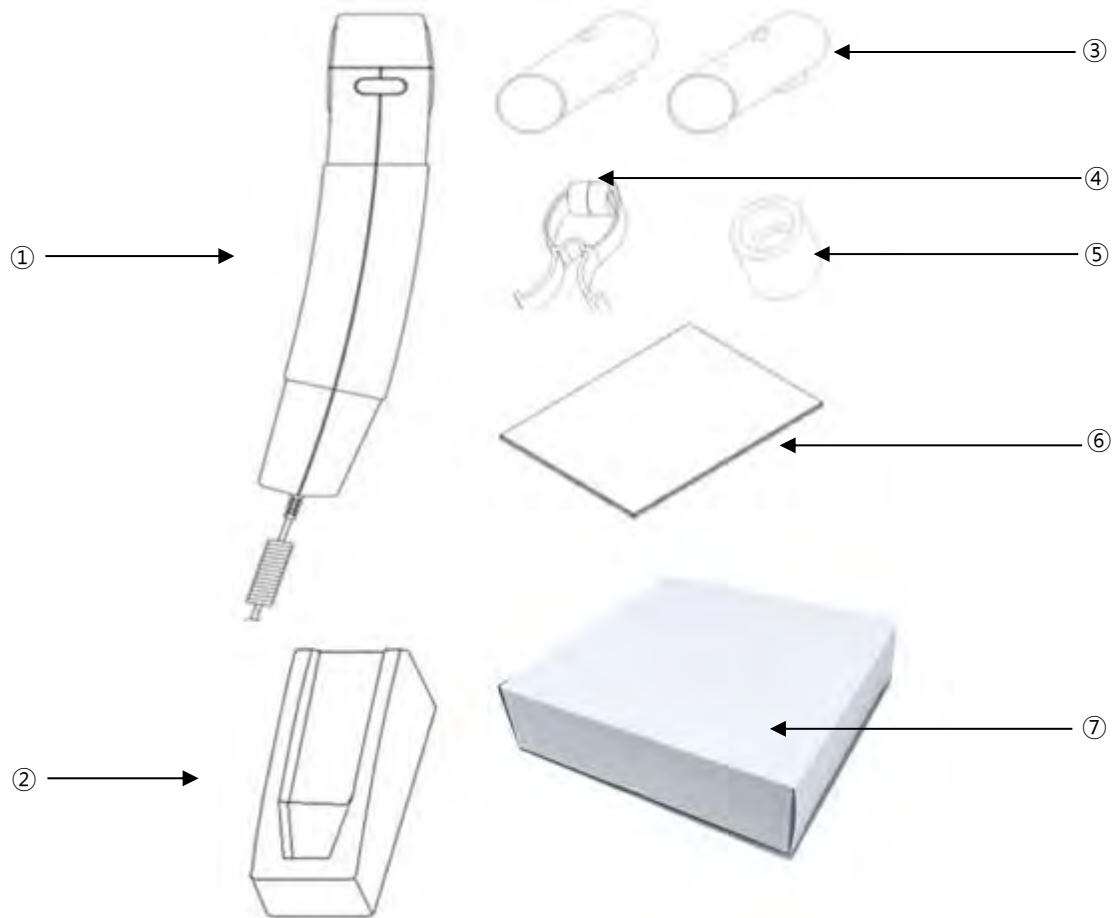
■ Spirometer (accessory)

- ① Spiro Handle (1ea.) - Length: 880mm (Normal), 3,480 mm (Max)
- ② Handle supporter (1ea.)
- ③ Disposable Mouthpiece (2ea.)
- ④ Nose Clip (1ea.)
- ⑤ Mouthpiece Adapter (1ea.)
- ⑥ Diagnostic Guide (1ea.)
- ⑦ Disposable Mouthpiece 1 box (100ea.)

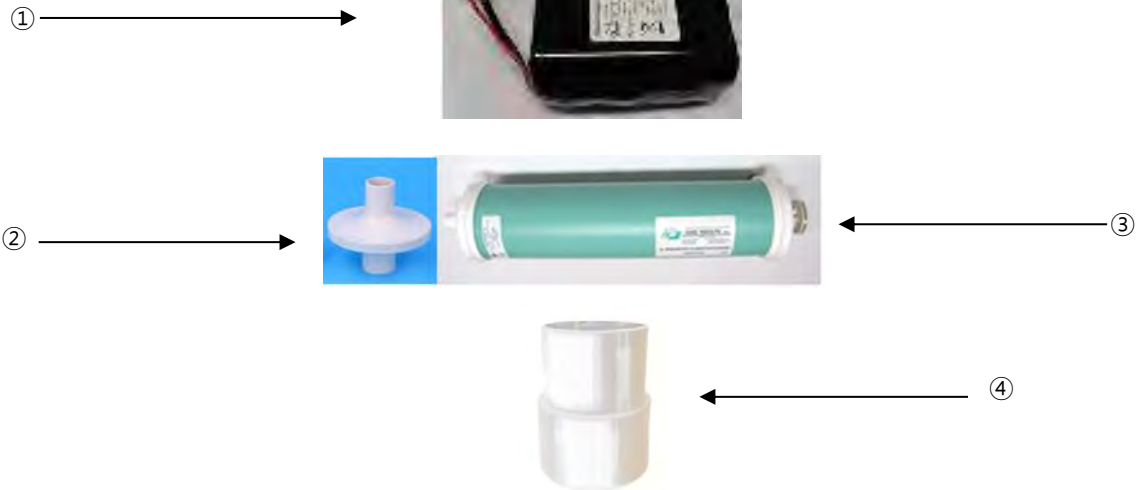
Optional Specifications

- ① Battery (1ea.) - Replaceable and Rechargeable, Lithium-ion, 10.8 V, 6500mA
- ② PFT Filter (20ea.)
- ③ Calibration Syringe [3L] (1ea.)
- ④ Spiro Connector (1ea.)

WARNING

You should use the PFT filter for COVID-19 patients.
If necessary, request additional purchases.

CAUTION

Using non-standard accessories other than the Bionet-provided supplies may cause signal distortion or noise. Be sure to use genuine accessories supplied by Bionet.

WARNING

Bionet is not liable for any problems caused by you not using the battery provided by Bionet. Make sure to use the genuine battery provided by Bionet.

Body Configuration

■ Top View

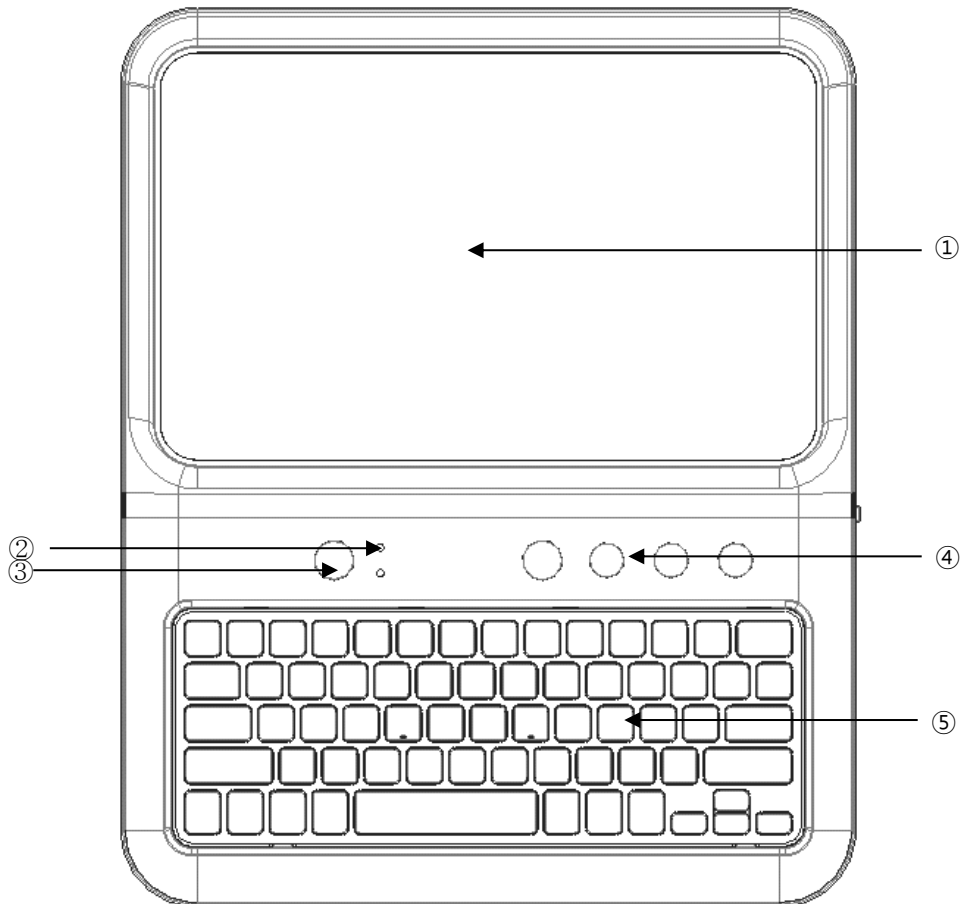

- ① LCD: It displays the operation status.
- ② LED: It shows the power connection status and battery status.
- ③ Power Switch: Power On/Off (Press longer than 3 seconds.)
- ④ Control Panel (Function Keys): Use them to select a function.
- ⑤ Control Panel (Keyboard): Input device (Option)

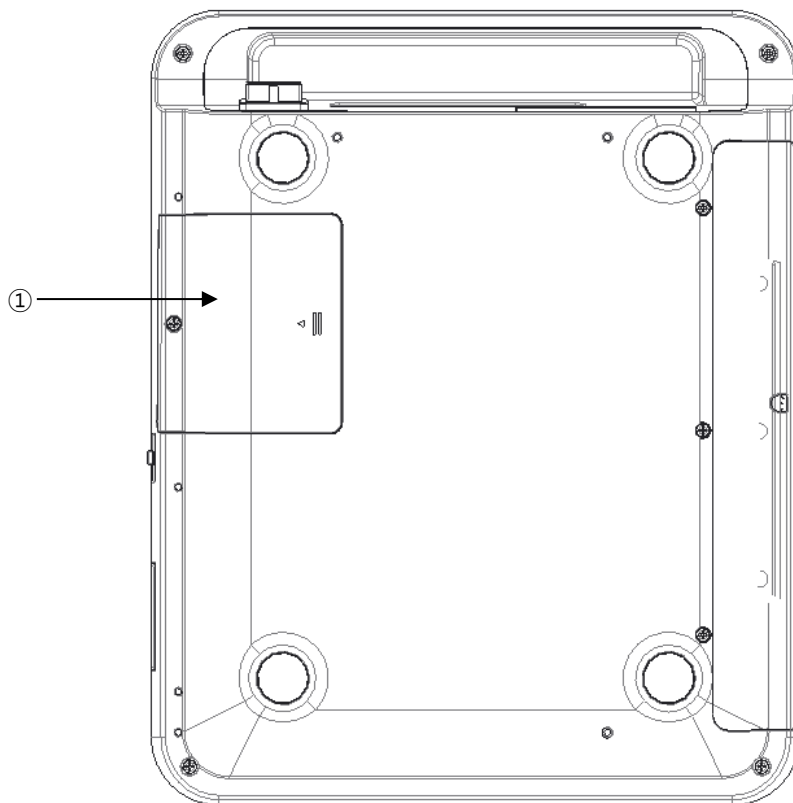
Bottom View

① Battery Cover: Insert a rechargeable battery here.

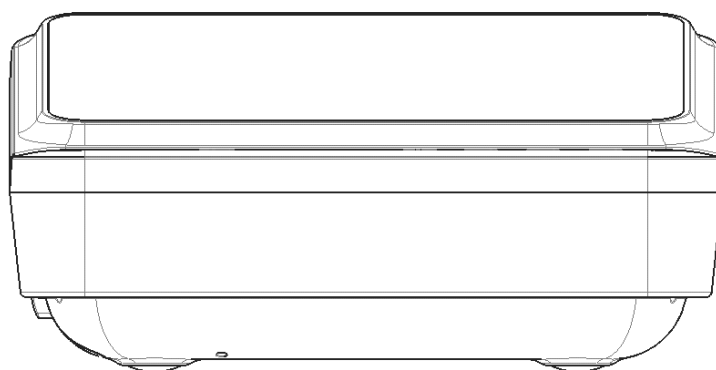
Front View

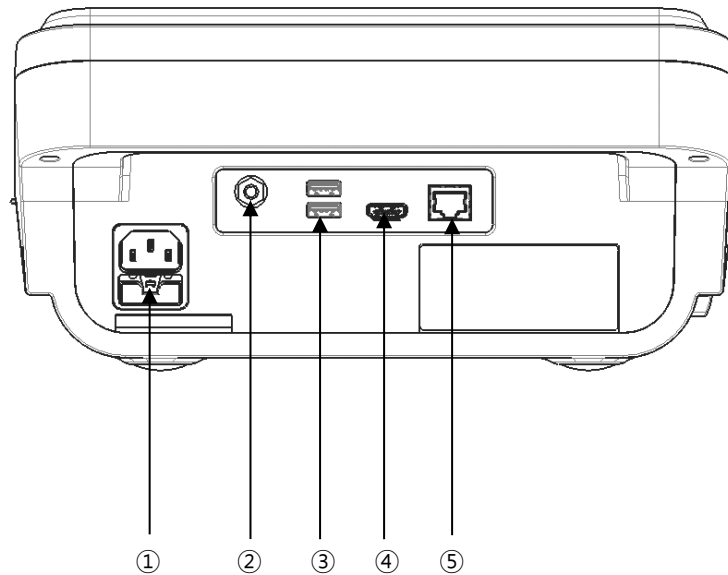
■ Rear View

- ① AC Power Terminal: AC power connection
- ② Grounding Terminal: Connect it to an external ground terminal if there is no protective grounding in the power supply.
- ③ USB Port: USB connection with external devices
- ④ HDMI Port: HDMI connection to external monitor
- ⑤ LAN Port: LAN connection with external devices

NOTE

The HDMI output specification of this equipment is 1024 x 600 @ 60Hz.

Depending on the specifications of the monitor, the screen may not display the output, so please check beforehand.

It is recommended to use IEC or KS certified monitors connected to this equipment.

It is recommended to use IEC or KS certified products for USB, computer, laptop, etc. connected to this equipment.

It is recommended to use certified products for all parts connected to equipment as well as HDMI and USB.

■ Left Side

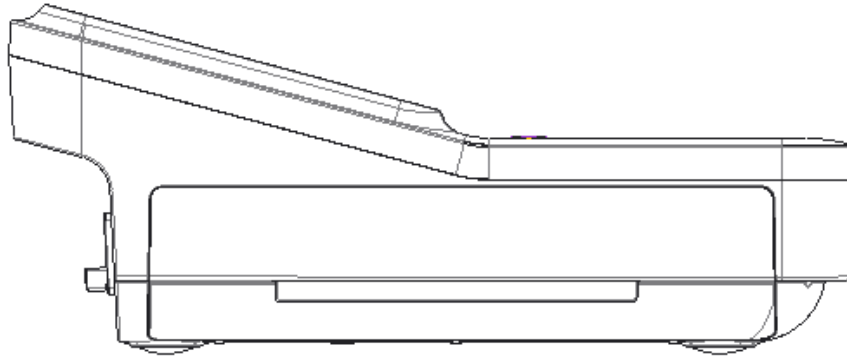

- ① Thermal Printer: It prints the patient's ECG waveform and analysis results.

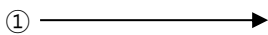

■ Right Side

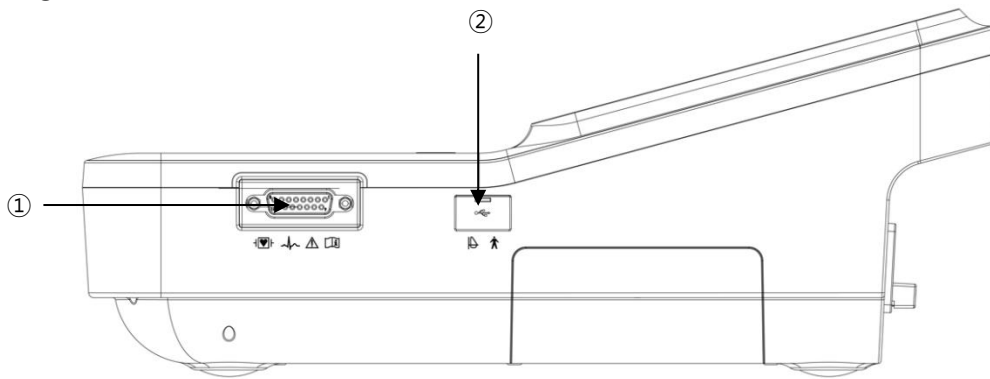

- ① Patient Cable connection port
- ② USB Port: USB communication with external devices, including a Spiro Handle

WARNING

There is a risk of electric shock if the Rest stand of the equipment is damaged or cannot be fixed to the equipment body. Do not use the product and immediately ask the manufacturer and the seller for repair.

NOTE

Do not open the cover of the equipment; it may cause an electric shock. Repair or disassembly of the equipment can only be performed by those who have product repair qualifications recognized by Bionet.

Spirometer Handle Configuration

▣ Front View of Spiro Handle

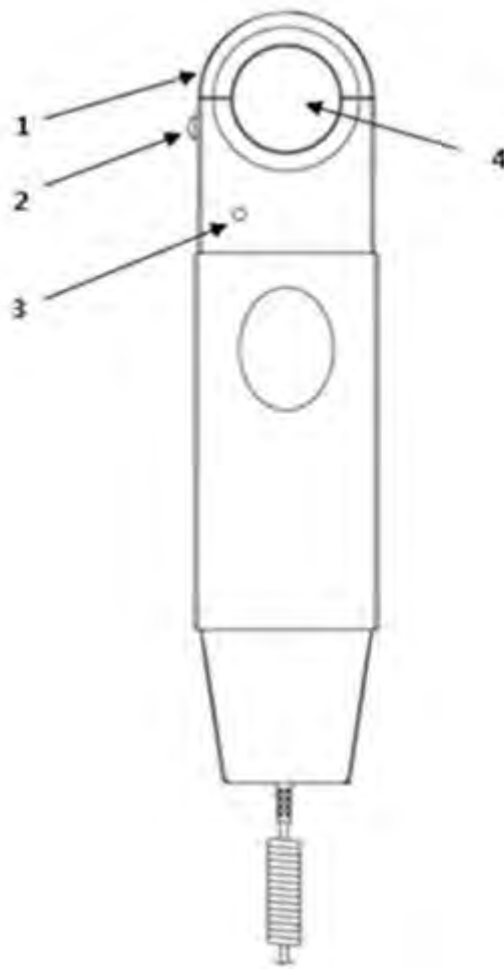

1. Front Cover: Mouthpiece anchoring cover
2. Front Cover Lock Switch: It locks the mouthpiece anchoring cover.
3. Operation Lamp: It shows the operation status (green).
4. Mouthpiece Hole: The mouthpiece is inserted into this hole.

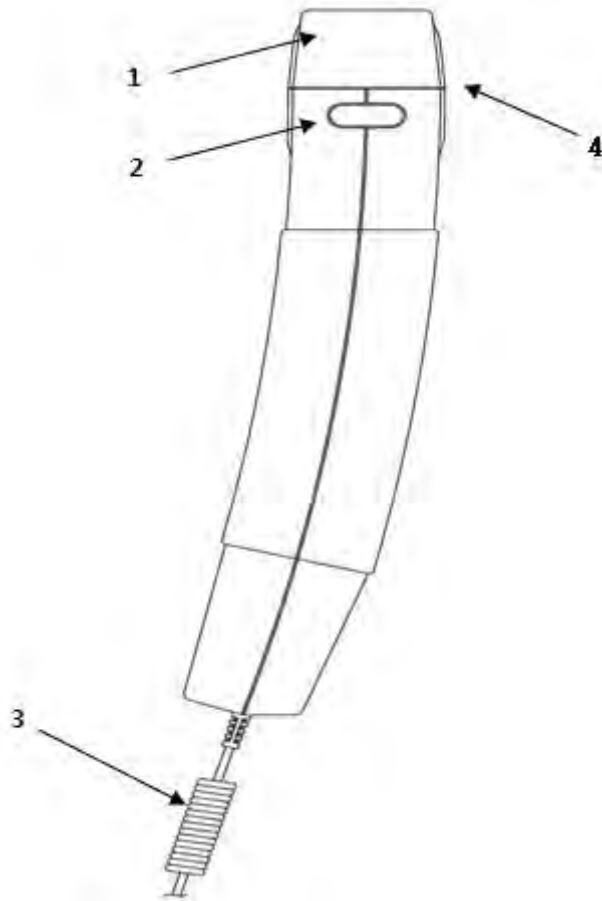
■ Left Side of Spiro Handle

1. Front Cover: Mouthpiece anchoring cover
2. Front Cover Lock Switch: It locks the mouthpiece anchoring cover.
3. Connected Wires: They are connected to the back of the main body.
4. Mouthpiece Hole: The mouthpiece is inserted into this hole.

▣ Right Side of Spiro Handle

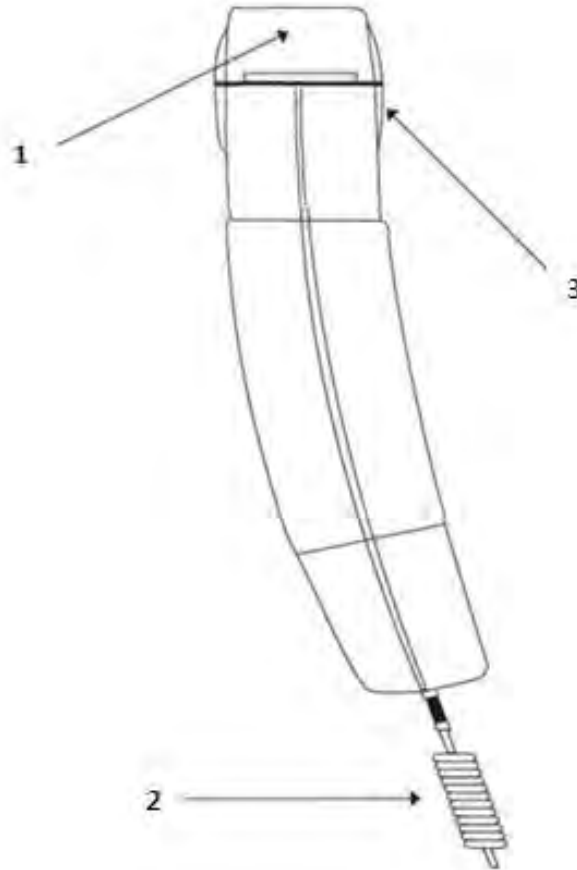

1. Front Cover: Mouthpiece anchoring cover
2. Connected Wires: They are connected to the back of the main body.
3. Mouthpiece Hole: Insert the mouthpiece into this hole.

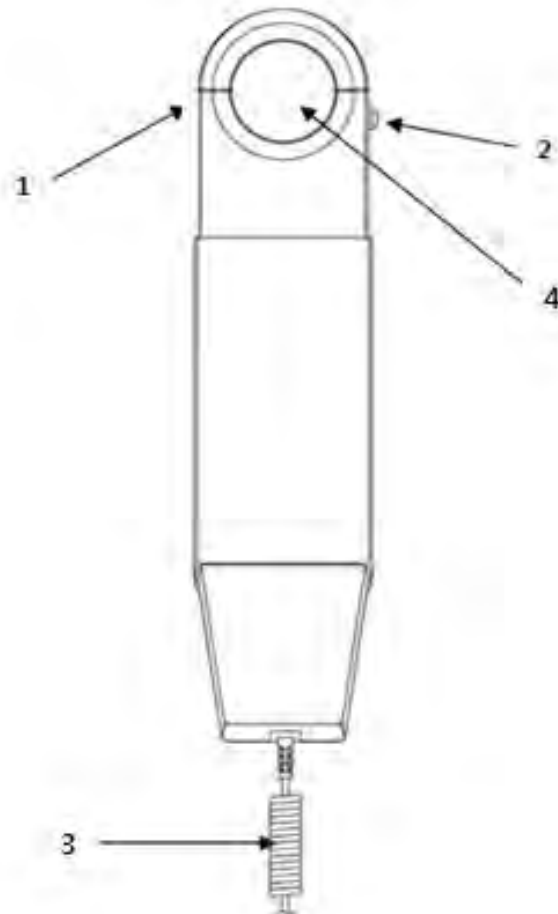
▣ Rear View of Spiro Handle

1. Front Cover: Mouthpiece anchoring cover
2. Front Cover Lock Switch: It locks the mouthpiece anchoring cover.
3. Connected Wires: They are connected to the back of the main body.
4. Mouthpiece Hole: The mouthpiece is inserted into this hole.

Front Part

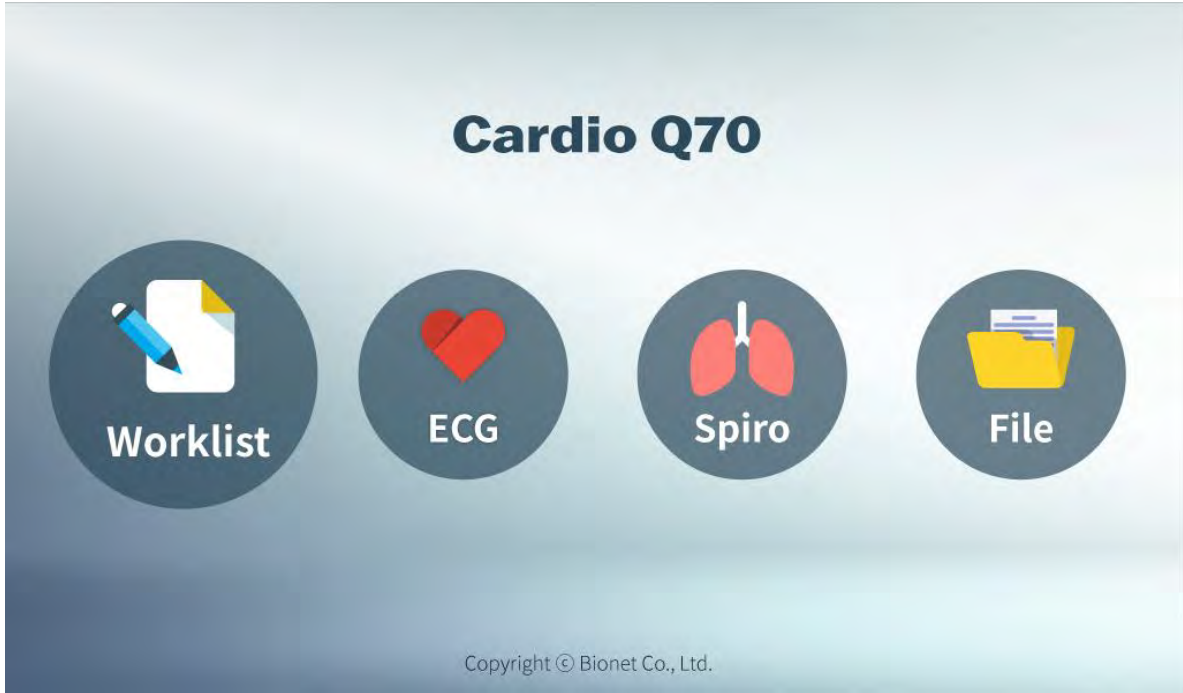

Graphic Display Window

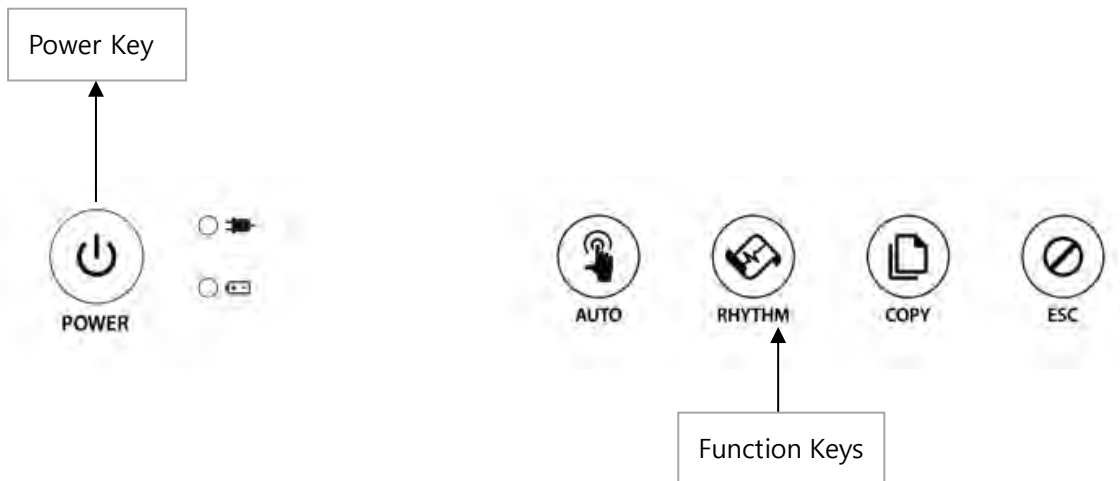

ECG Graphic Window

Refer to the following description about the ECG graphic window.

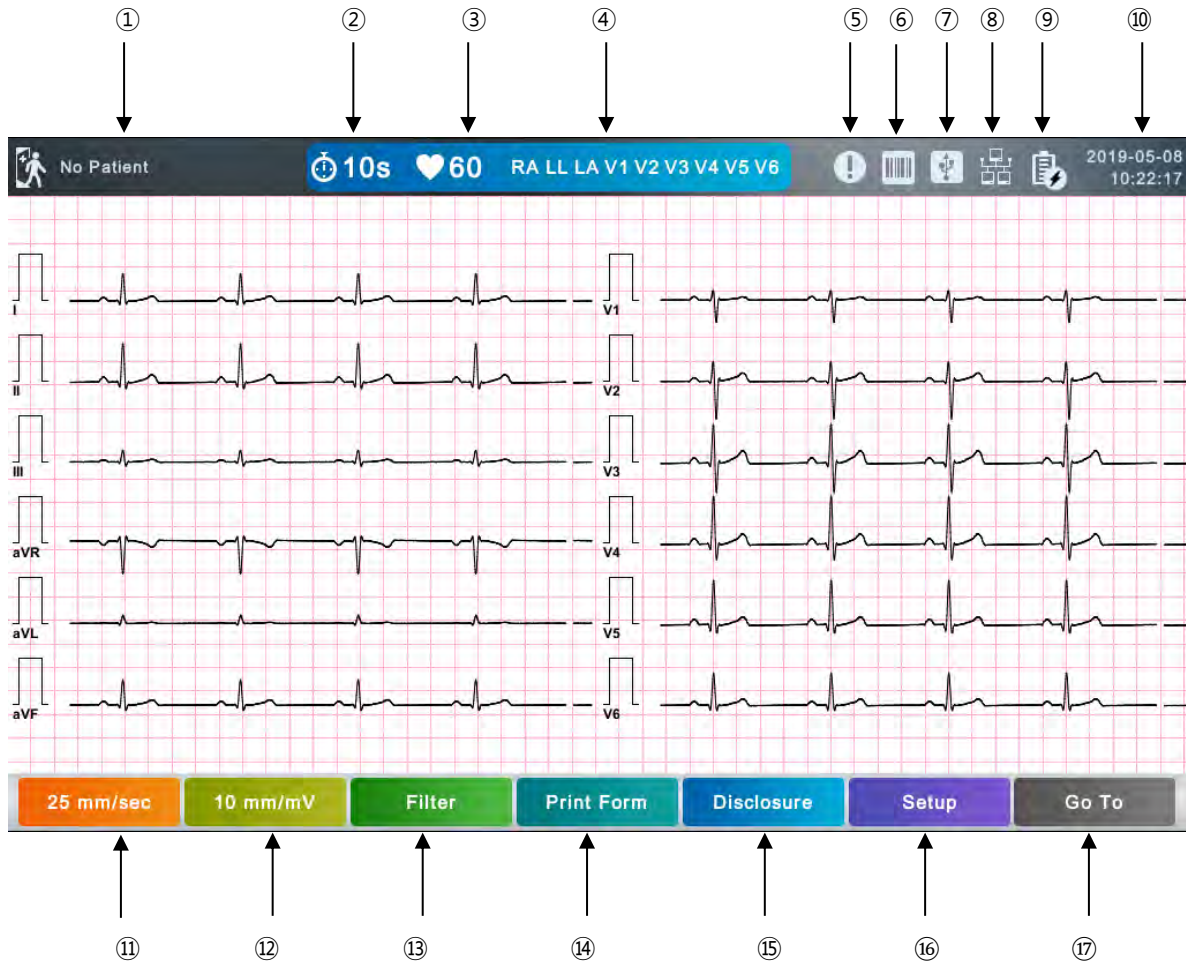

- ① Patient ID and name: Touch this button to enter patient information.
- ② ECG recording mode (10s, 1m, 3m, 5m, 10m, 20m, or 30m): Touch this button to set a mode.
- ③ Heart rate
- ④ Lead fault status and lead location
- ⑤ Study Queue (List of failed transmissions) icon
- ⑥ Connection status of the external device (barcode reader)
- ⑦ Connection status of the external device (USB memory)
- ⑧ Network connection status: Touch this button to set the network.
- ⑨ Battery status or AC power connection status
- ⑩ Current date and time: Touch this button to set the date and time.
- ⑪ Current print speed: Touch this button to set the print speed.

- ⑫ Current gain: Touch this button to set Gain.
- ⑬ Filter: Touch this button to set a filter.
- ⑭ Print Form: Touch this button to set screen output and print form.
- ⑮ Disclosure: Touch this button to run Disclosure.
- ⑯ Setup Menu
- ⑰ Go To: Touch this button to move to other menus such as ECG, Spiro, File, or Worklist.

NOTE

The detection range of heart rate is 30-300 bpm with ± 3 bpm of error range.

Spiro Graphic Window

Refer to the following description about the spirometry graphic window.



- ① Patient ID and name: Touch this button to enter patient information.
- ② Study Queue (List of failed transmissions) icon
- ③ Connection status of the external device (barcode reader)
- ④ Connection status of the external device (USB memory)

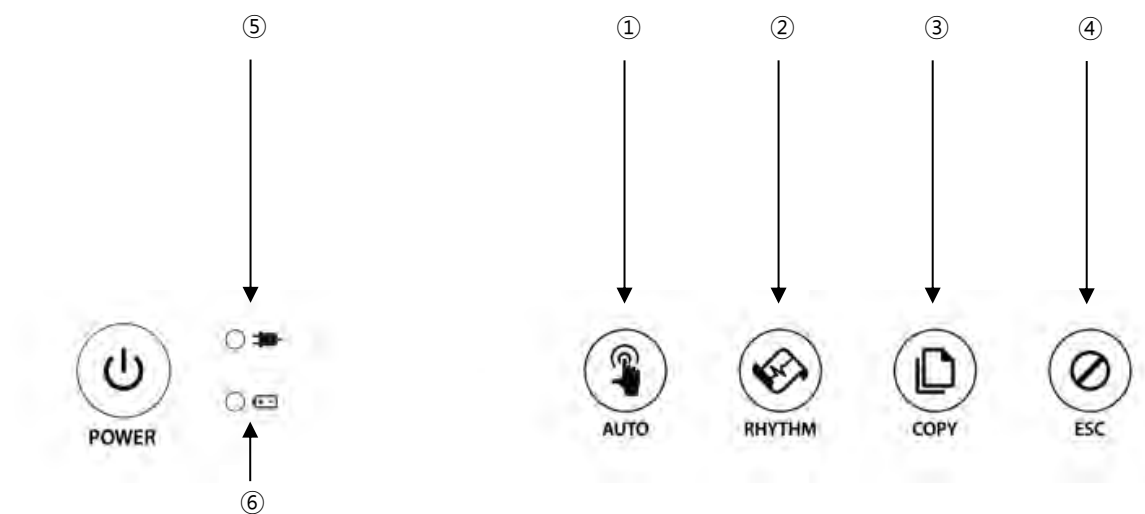

- ⑤ Spiro Handle connection icon
- ⑥ Network connection status: Touch this button to set the network.
- ⑦ Battery status or AC power connection status
- ⑧ Current date and time: Touch this button to set the date and time.
- ⑨ Forced Vital Capacity Test Menu
- ⑩ FEV1/FEV6 Test
- ⑪ Slow Volume Capacity Test menu
- ⑫ Maximum Voluntary Ventilation Test Menu
- ⑬ Calibration Menu
- ⑭ Setup Menu
- ⑮ Touch this button to move to other menus such as ECG, Spiro, File, or Worklist.

Function Keys





■ Button Description

①		<p>AUTO</p> <p>1. Short press</p> <p>Press the key briefly to run ECG exam. You will use this key the most, from running an ECG diagnostic test to storing, transfer, and printing.</p> <p>2. Press and hold (more than 3 seconds)</p> <p>The signal is acquired for 10 seconds or for a certain period of time (1 minute, 3 minutes, 5 minutes, 10 minutes, 20 minutes, or 30 minutes). It is processed and provided in the format you choose.</p>
---	---	---

②		RHYTHM A real-time ECG waveform is continuously printed or prepared as a report.
③		COPY Previously saved data will be processed and printed in the same way as before or as modified in your settings.
④		ESC You can cancel the operation or switch to the previous mode by entering the main menu.

■ Indicating Lights

⑤		AC power connection indicator: The LED lights yellow green when the equipment is connected to AC power.
⑥		Battery charge indicator with AC connected: During operation, if the battery is fully charged, the LED lights yellow green, otherwise it turns orange.

Power

■ AC power

When the equipment is connected to AC power, the Power LED on the front lights green. When a battery is mounted, it is charged in automatic charging mode.

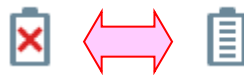

< AC Power > < Battery Power >

Warning

Be sure to connect this equipment to a power supply with protective grounding.

■ Battery Power

If you turn on the battery-mounted equipment with the AC power supply being cut off, the

equipment is powered by the battery and the battery indicator is displayed in the upper right corner of the LCD screen. If the battery power is low, an alarm sounds. Connect AC power quickly to the equipment, otherwise, it automatically turns off after a certain period of time.

- Time required to fully charge the equipment that has been turned off after being completely discharged: Up to 3 hours
- Continuous use time after full charge:
 - About 10 hours in standby mode without ECG recording
 - You can print up to 350 ECG recordings in 12-channel format at 25mm/s and 10mm/mV settings.
- Battery Type: Lithium-ion battery (10.8V, 6500mAh)
A lithium-ion battery is a rechargeable battery containing lithium-ion cells. Each battery includes an electrical remaining capacity measurement circuit and a safety protection circuit.

WARNING

- The battery charge display is accurate only when the battery is functioning normally.
- Capacity or operating time of old or defective batteries is significantly compromised.

NOTE

- Without an AC power supply, it takes up to 15 seconds for the battery-charging display to reflect the actual capacity of the internal battery.

NOTE

- Bionet recommends replacing the lithium-ion battery after 24 months of use.
- Battery life depends on the frequency of use.
- Continued use by the battery power reduces the battery life and shortens the time of replacement.
- Be sure to recharge the battery before it is completely discharged.

■ Battery Power Status



: Fully charged.



: Half charged.



: Low charged.



: Almost discharged.



: Being charged.

■ Replacing the Battery

Replace the battery with the same type.

- Battery Type: Lithium-ion battery (10.8V, 6500mAh)
- A lithium-ion battery is a rechargeable battery containing lithium-ion cells. Each battery includes an electrical remaining capacity measurement circuit and a safety protection circuit.
- When to replace: When the equipment is connected to a power source, the battery is charged automatically. It cannot be charged separately from the equipment. The battery can be recharged about 300 times or more. Replace it if you cannot use it for longer than 20 minutes even after full charge. In case the battery is damaged or leaks, replace it immediately. Do not use a damaged battery on the equipment.

WARNING

- Pay attention to the polarity when replacing the battery.
- Bionet strongly recommends using the battery provided with the equipment.
- Using an unauthorized battery may damage the equipment.

The Effect of Lithium-Ion Technology on the Battery

Find out about lithium-ion battery technology here.

The battery is discharged naturally even when not installed in the equipment. Discharging is

caused by the current demanded by the lithium-ion battery integrated circuit. Battery is self-discharged due to the nature of lithium-ion cells, and the self-discharge rate doubles for every 10°C (18°F) rise in temperature.

Battery retention loss is greater at higher temperatures. As the battery ages, it may not be fully charged, as a result, the total charge capacity used for saving and using gradually decreases.

Conditioning Guidelines

Check battery performance by fully charging and completely discharging it every 6 months.

Storage Guidelines

Store the battery between 20°C and 25°C (68°F and 77°F) when it is set aside separately. When the battery is installed in the equipment and connected to AC power, the temperature of the battery increases by 15°C to 20°C (59°F to 68°F) at room temperature, which shortens the life of the battery.

When a battery is installed in the equipment with AC power being connected, normally the equipment does not use the battery power. Battery life may be less than 12 months. Store the battery along with the equipment to prevent being lost and stolen, and separate the battery from the equipment when moving the equipment.

Recycling the Battery

Replace the battery when it is no longer charged. The battery can be recycled. Remove the old battery from the monitor and follow your local recycling guidelines.

WARNING

- Do not incinerate the battery or store it at high temperatures as it may explode, which may cause you serious injury.
- Do not use the battery that has been impacted, disfigured, or submerged; dispose of it.

5) Installing System

Installation Precautions

Note the following when installing the Cardio Q50 / Cardio Q70.

- Use the equipment within the ambient temperature of 10~40°C and humidity of 30~85%.
- Check the connection of the power cord and handle the patient cable with care.
- Do not plug multiple cords into a single electrical outlet.
- Install the equipment body on a flat surface.
- Connect the ground if noise occurs.
- Do not use the electrical cords that generate connection noise.
- All settings stay saved in the internal memory even when the equipment is turned on and off.
- Handle the equipment with care as it is sensitive to impact.
- Install the equipment in a place with proper ambient temperature and humidity, and away from dust and flammable materials.

Connecting Power

- Connect the power cable to the power supply and the power terminal on the back of the Cardio Q50 / Cardio Q70 to power on.

Connecting Patient Cable

- Connect the Patient Cable to the patient cable connection port on the right side of the equipment.
- Connect the limb electrodes to RL (N), LL (F), RA (R), and LA (L) terminals and chest electrodes to V1(C1), V2 (C2), V3 (C3), V4 (C4), V5 (C5) and V6 (C6) terminals of the patient cable.

Inserting ECG Recording Paper

- Pull forward the printer handle on the front of the equipment to take out the printer tray.

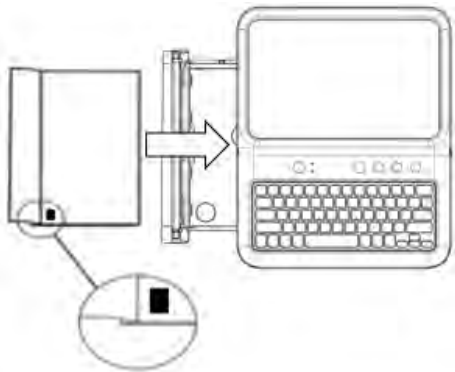

Insert the ECG recording paper with the area to be printed facing up as shown in the picture, making sure that the black mark on the paper is located at the bottom.

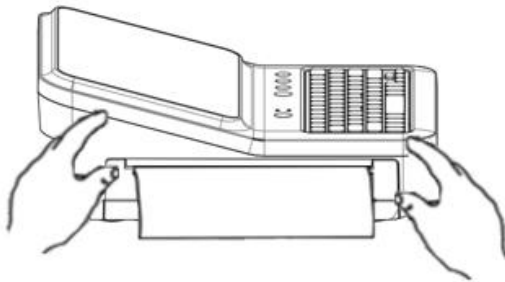

Push back in the tray while supporting the equipment with both hands as shown in the picture.

NOTE

Push the printer tray all the way in until you hear a click.

CAUTION

- Place the ECG recording paper straight so that it is not tilted.

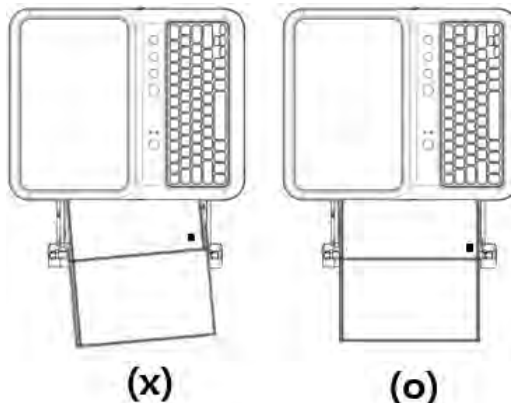

- Tear the printed paper from the top or bottom along the dotted line.

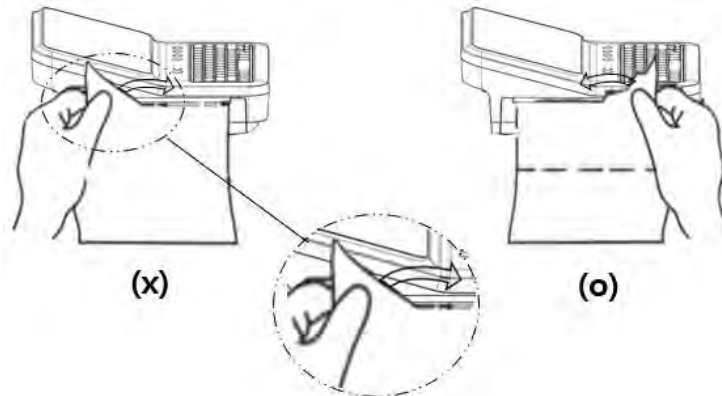

- Do not pull the ECG recording paper while being printed.

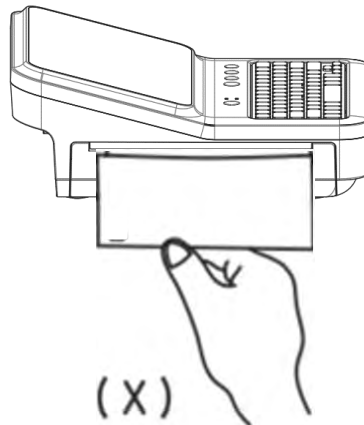

- Take the following measures for paper jams:

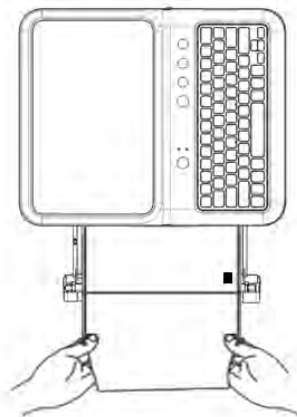

- 1) Turn off the equipment.
- 2) Pull the printer tray forward to take it out.
- 3) Pull out the ECG recording paper, and tear and remove the jammed paper.

- If you keep printing for more than 10 minutes with the RHYTHM key, the ECG recording paper may be scorched.

WARNING

Use only the ECG recording paper provided by Bionet for ECG recording. Otherwise, the poor printing quality may affect the doctor's diagnosis. Bionet is not liable for any problems caused by you not using the ECG recording paper provided by Bionet.

CAUTION

Do not use the equipment together with other electronic devices.

CAUTION

Use the mouthpieces that come with the equipment or those which have been certified for biocompatibility according to international standards.

WARNING

Modifications to this equipment are not allowed.
Do not disassemble or modify this equipment without the manufacturer's approval.
Repair or disassembly of the equipment can only be performed by those who have product repair qualifications recognized by Bionet.
Bionet is not liable for any problems arising from the disassembly and modification of equipment by an unqualified person.

Connecting the Network

As only the service technicians can connect this equipment to the network, consult with the IT staff in the hospital in advance.

Follow IEC 80001-1, which is the Risk management of IT networks to which medical devices are connected.

LAN Network

Generally, the LAN networks are configured based on a star topology. You can group Individual devices together via layer-n-switch. Other data traffic is separated by other VLAN networks. Configure the network according to this manual and your network specifications.

LAN connection specifications are described in the following standards.

- Wired Network: IEEE 802.3

- Wireless Network: IEEE 802.11 (a, b, g, n)

The data transmitted on the wireless network can be secured by one of the following methods:

- WEP
- WPA-PSK
- WPA2-PSK

If the equipment is used as a layer-2-switch or layer-3-switch, the port settings must be configured on the network switch. Configure the network of Bionet equipment to be compatible with the specifications of your operating organization.

The equipment exchanges data with other medical devices via a LAN network. The network must support the following protocols:

- TCP/IP
- BROADCAST

VLAN Network

If data is exchanged within a single network, you must establish an independent VLAN network for clinical information systems, such as a network dedicated to medical devices in hospitals. Also, you should build a network system that detects and defends against denial-of-service attacks by establishing a system dedicated to DDos protection.

When using an inappropriate network

If your network does not meet the requirements, the following may occur:

- Without a firewall and antivirus software:
 - Data is not protected.
 - Data is transferred incomplete or not transferred at all.
 - Data may be sent to the wrong server.
 - Data may be blocked, forged or damaged.
- Without an independent network configuration or dedicated system for DDos defense:
 - You may be subject to denial of service attacks (DDos). In this case, the equipment may become slow or may not work properly. In rare cases, you may experience the delayed or repeated booting.

Network Security

- Ensure that appropriate security measures are taken to protect data transmission.
- Security of the network is the sole responsibility of the network operator.
- Bionet recommends the following to guarantee the security of the network.
 - Define access authorization for the configuration of the host system so that no unauthorized alterations of the system can occur.
 - Install an up-to-date antivirus/firewall program so that any malware cannot jeopardize the system.
 - Update the security and software regularly.
 - Apply the "Risk Management of IT Networks" according to IEC 80001-1.

6) Starting the System

When you turn on the equipment, the product name is displayed and the login screen appears as shown in the picture below. Enter your user information to log in.

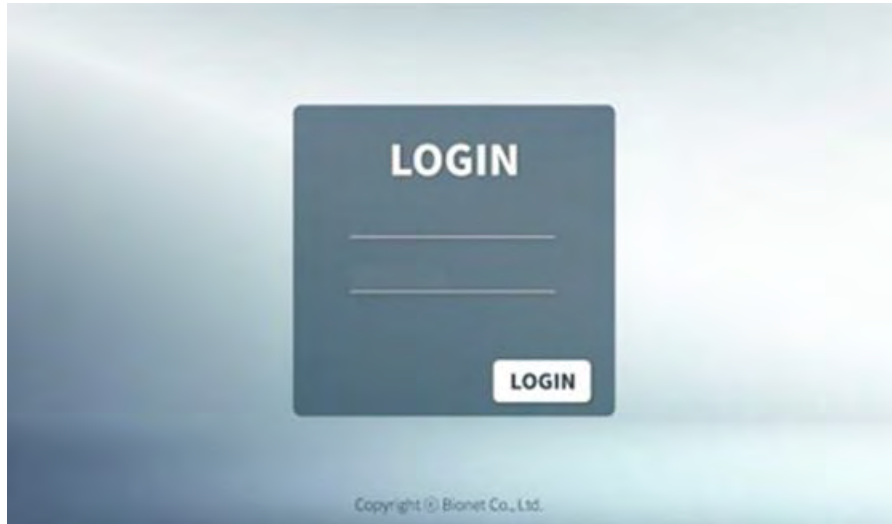

Login

Enter your ID and password.

Roles and privileges are assigned to individual users and may affect each user's scope of access to areas of the workflow and available functions.

If a function is colored in gray and cannot be entered, it means that the user logged in does not have the privileges to perform the (greyed) task or the task is not available in the current screen.

See **Chapter 7. User Information Management** for individual users and their privileges.

After login, the menu screen appears as shown below.

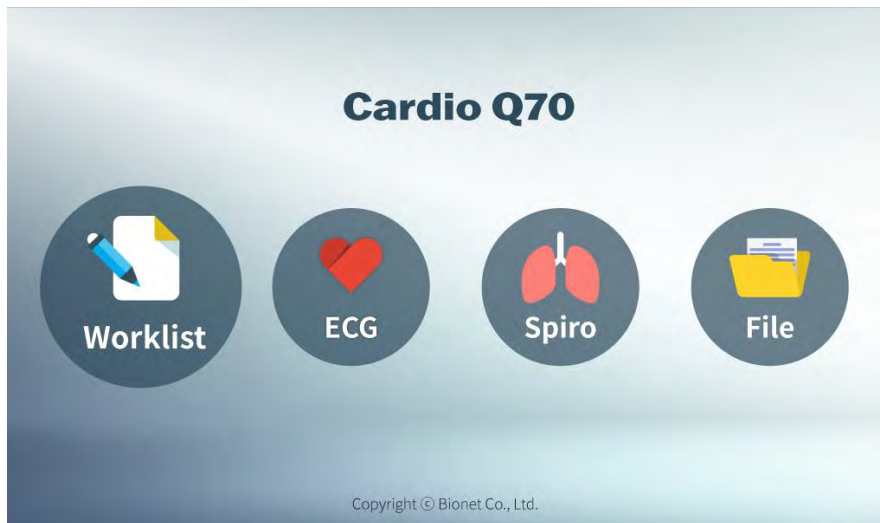





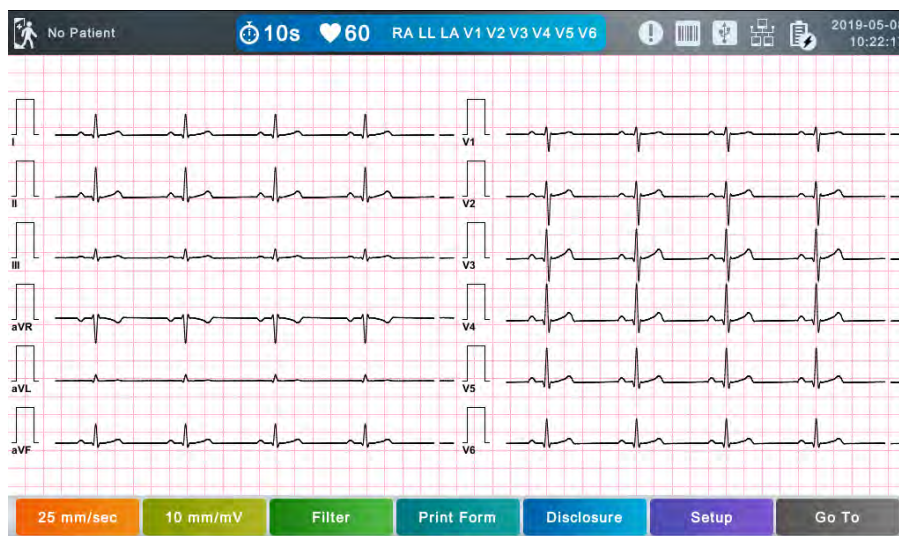









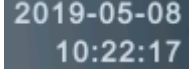

Touch a menu to load the corresponding main screen.

The picture below shows the ECG main screen that is loaded when you choose the ECG menu.

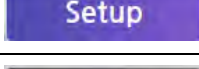

The following is a description of the ECG initial screen menu.

Menu	Description
	Patient information
	ECG Recording mode (10s, 1m, 3m, 5m, 10m, 20m, or 30m)
	Heart rate

	Lead Fault information
	Move to Retry Queue (to manage files that failed to be sent to server).
	Barcode reader connection status
	USB Memory connection status
	Current network connection status: Touch this icon to set.
	Power status (AC power or battery)
	Current date and time: Touch this icon to set date and time.
	Current Output Speed: Touch this button to set the speed of the screen output and printing.
	Current Gain: Touch this button to set Gain.
	Touch this button to set Filter.
	Touch this button to set Print Form.
	Touch this button to set Disclosure.
	Touch this button to set the System.
	Go to the main screen: ECG, Spiro, File, or Worklist.

Touch [Worklist] to bring up the exam-requested patient management screen as follows.

The screenshot shows the 'Worklist' application interface. At the top, there is a search icon, the title 'Worklist', a page indicator '1/9', and navigation arrows. The main area is a table with columns: ID, Name, Sex, Age, DateTime, and Study. The table contains 9 rows of patient data. At the bottom, there is a menu bar with buttons: Select, Exam, Update, Patient, Setup, and Go To.

	ID	Name	Sex	Age	DateTime	Study
1	05082710	takdq	M	43yr	2019-05-08 11:07:30	ECG
2	05082710	takdq	M	43yr	2019-05-08 11:07:19	SVC
3	05082710	takdq	M	43yr	2019-05-08 11:07:16	MVV
4	05082710	takdq	M	43yr	2019-05-08 11:07:04	FVC
5	05082705	swxmb	F	64yr	2019-05-08 11:06:02	ECG
6	05082704	tdviw	M	54yr	2019-05-08 11:05:56	ECG
7	05082703	whivj	M	32yr	2019-05-08 11:05:49	ECG
8	05082702	utnhe	M	46yr	2019-05-08 11:05:45	ECG
9	05082701	pdcvj	M	42yr	2019-05-08 11:05:39	ECG

The following is a description of the Worklist menu.

Menu	Description
	Search data by entering search criteria.
	Order number in the current location/entire order number
	Go to the previous page.
	Go to the next page.
	Go to the exam screen.
	Load Worklist. It appears when PACS is connected.
	Delete the selected files. It appears when server is connected.
	Confirm patient information.
	Touch this button to set the System.
	Go to the main screen: ECG, Spiro, File, or Worklist.

Touch [File] to bring up the ECG data management screen as follows.

	ID	Name	Sex	Age	DateTime	Study
1	w24567806432	ljio	F	45yr	2019-04-30 18:50:35	FVC
2	w24567806432	ljio	F	45yr	2019-04-30 18:42:25	FVC
3	w24567806432	ljio	F	45yr	2019-04-30 18:16:15	FVC
4	w24567806432	ljio	F	45yr	2019-04-30 17:35:26	FVC
5	w24567806432	ljio	F	45yr	2019-04-30 16:05:59	FVC
6	w24567806432	ljio	F	45yr	2019-04-30 15:46:15	FVC
7	w24567806432	ljio	F	45yr	2019-04-30 14:37:03	FVC
8	w24567806432	ljio	F	45yr	2019-04-30 14:11:49	FVC
9	w24567806432	ljio	F	45yr	2019-04-30 14:02:53	FVC
10	w24567806432	ljio	F	45yr	2019-04-30 11:27:53	FVC





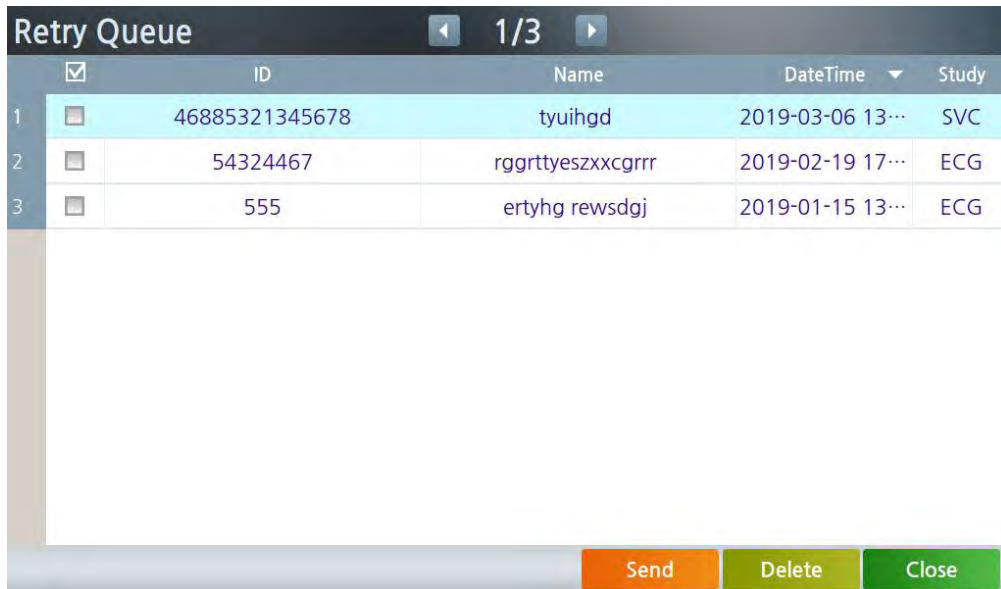

The following is a description of the File menu.

Menu	Description
	Search data by entering search criteria.
	File number on the current location/entire file number
	Go to the previous page.
	Go to the next page.
	Multi-option menu
	Print the selected files.
	Delete the selected files.
	File preview
	Confirm patient information.
	Touch this button to set the System.
	Go to the main screen: ECG, Spiro, File, or Worklist.

Touch  (Retry Queue icon) to bring up the Retry Queue data management screen as follows. Retry Queue manages data that has failed to be sent to the server.



The following is a description of the Retry Queue management menu.

Menu	Description
	File number on the current location/entire file number
	Go to the previous page.
	Go to the next page.
	Transfer the selected data.
	Delete the selected data.
	Close the window.

NOTE

-  The icon appears on the right top corner only if there is an error while sending files.

Part 1 Recording ECG



Chapter 2. ECG Recording Preparation

1) Attaching the Electrodes

When you touch **RA LL LA V1 V2 V3 V4 V5 V6** (Lead Fault Information) located in the center of the menu bar at the top of the ECG Main screen, a picture showing where to attach the electrodes is displayed.

To record a standard 12-lead ECG, attach electrodes to the patient's body as shown below.

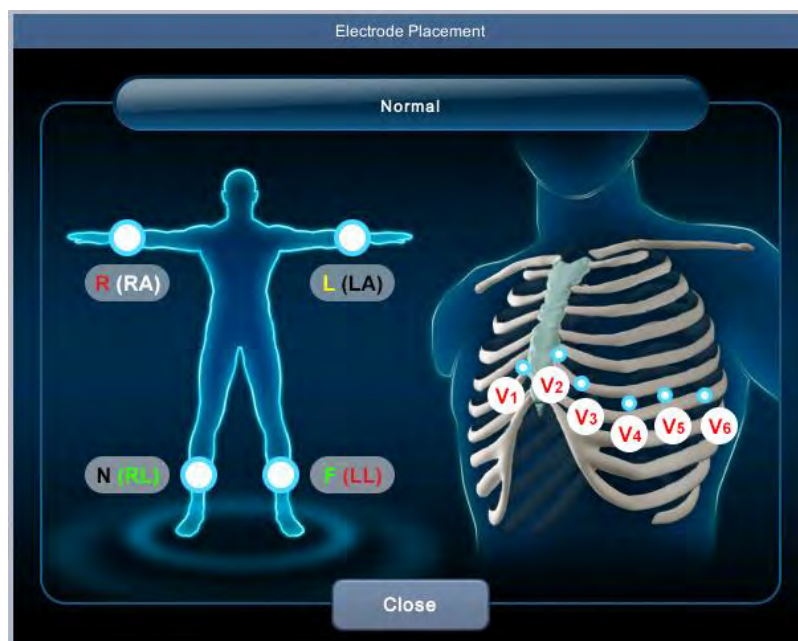

The positions to attach limb electrodes are as follows:

- RL (N): Right leg
- LL (F): Left leg
- RA (R): Right arm
- LA (L): Left arm

The positions to attach the chest electrodes are as follows:

- V1 (C1): Boundary of fourth intercostal on right side of chest
- V2 (C2): Boundary of fourth intercostal on the left side of chest
- V3 (C3): Mid-location between V2 (C2) and V4 (C4)
- V4 (C4): Mid-location of the front side of fifth intercostal collarbone
- V5 (C5): Front armpit on the horizontal line with V4 (C4)
- V6 (C6): Mid-armpit on the horizontal line with V4 (C4), V5 (C5)

2) Connecting Electrodes

* Checklist

- Before the exam, check the condition of the equipment and patient, and whether each electrode is well attached.
- Make sure that there are no mechanical hazards.
- Check the status of cables and accessories connected externally.
- Check the status all the measuring devices for the patients

Connecting Patient Cable

Connect the patient cable to the port on the right side of body and connect limb electrodes to the terminals of RL (N), LL (F), RA (R), and LA (L) of patient cable connected in the Cardio Q50 / Cardio Q70 and chest electrodes to the terminals V1 (C1), V2 (C2), V3 (C3), V4 (C4), V5 (C5) and V6 (C6).

How to Attach the Electrodes

Have the patient lie down on the bed and release the tension in the skin area where the electrodes will be attached. Clean the area with disinfected alcohol or water before attaching electrodes. In case the patient is hairy on the attaching spots, shave them. If the attachment body part is curved and it is difficult to attach the electrodes, attach them to the positions that are as similar as possible without a curve.

If the noise is severe even if you have used alcohol or water, apply the ECG gel to the attaching spots before attaching the electrodes.

Be sure to wipe off the used ECG Gel, because if it gets dried and hardened, it can generate noise in the ECG signal.

WARNING

Be sure to use only the electrodes and patient cable provided by Bionet. Bionet is not liable for any problems caused by your using unauthorized parts.

What to Do with Poor Lead Connection

Turn on the equipment, enter the ECG mode, and check the connection of all leads and the noise level of the waveform. A message appears in case of a lead fault.



RA LL LA V1 V2 V3 V4 V5 V6

NOTE

- Lead fault message appears only when Lead fault is set to On in ECG General Setup. Otherwise, it will not appear.
- Fault leads are shown in red and saturation leads in yellow.
- Proceed with the ECG exam only when the leads are connected properly.

Take the following measures when the lead connection is poor.





- When the electrodes come off from the skin: Reattach the electrodes following the electrode attachment method.
- When conductivity between the skin and the electrodes is weak: Apply the ECG gel to the electrode-attaching spots and reattach the electrodes.

If the ECG signal is not accurately acquired even after you try all the solutions above, the patient cable may be non-conforming. Contact Bionet's service center.

3) Recording ECG

- Enter accurate patient information.
- Connect the ECG cable to the patient in compliance with the ECG measurement preparations.
- Check or change settings such as Filter, Gain, Output Speed, Channel Configuration, Rhythm, etc.
- Refer to What to Do with Poor Lead Connection if the waveform drawn in the LCD screen is abnormal or there is too much noise.
- If the waveform displayed on the LCD screen is normal, press the [AUTO] key to record the ECG.
- Press the [COPY] key either to show the 10-second data on the screen, as originally entered, or print it out as modified in your settings.
- Press the [RHYTHM] key to print out the ECG signal waveform in real-time.
- Press the [ESC] key to stop printing or saving the ECG results.

The following is a description of the ECG recording menu.

①		<p>AUTO</p> <p>1. Short press</p> <p>Press the key briefly to run ECG exam. You will use this key the most, from running an ECG diagnostic test to storing, transfer, and printing.</p> <p>2. Press and hold (more than 3 seconds)</p> <p>The signal is acquired for 10 seconds or for a certain period of time (1 minute, 3 minutes, 5 minutes, 10 minutes, 20 minutes, or 30 minutes). It is processed and printed in the format you choose.</p>
②		<p>RHYTHM</p> <p>A real-time ECG waveform is continuously printed or prepared as a report.</p>
③		<p>COPY</p> <p>Previously saved data is printed unabridged or as modified in your settings.</p>
④		<p>ESC</p> <p>You can cancel the operation or switch to the previous mode by entering the main menu.</p>

4) Basic Setup

General Information

When you turn on the equipment, top and bottom menu bars and graphic window appear on the LCD screen.

Top menu bar: Patient Information, Test Mode, Heart Rate, Lead Fault, External Device Connection Status, Network Status, Power Status, Current Date and Time

Bottom menu bar: Output Speed, Gain, Filter, Print Form, Disclosure, and Setup.

Touch the menu buttons on the LCD screen to change settings.

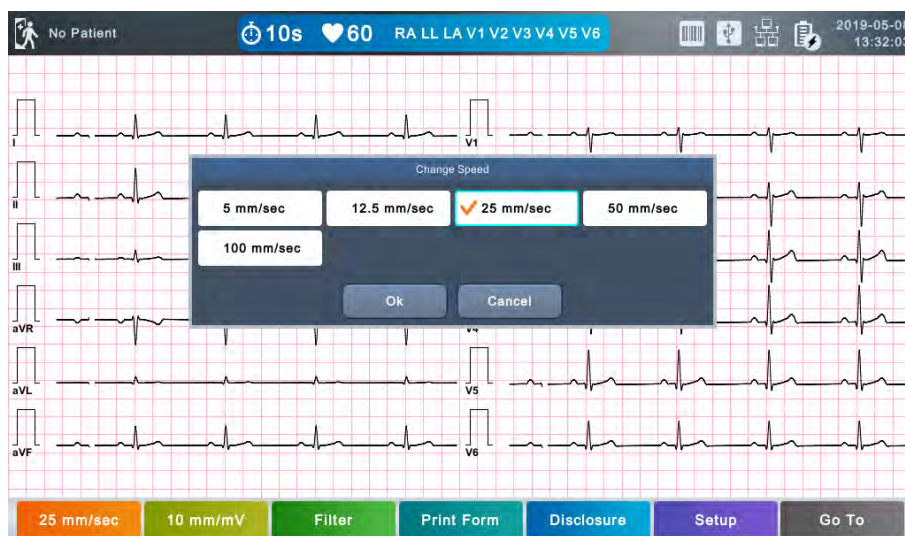

Setting Values Using Touch Screen

- Selecting Menu

Touch the menu buttons on the screen.

- Setting the Value

Select a menu and touch [OK].

Screen Output

The current ECG signal is drawn on the LCD screen in real-time.

Start the test after confirming that the signal is correctly transmitted from all leads.

There are 6x2 mode and 3x4+1 mode for the output format of the ECG waveform, which you can change in the Setup → ECG → General → Display Form menu.



In 3x4+1 mode, the waveform is drawn as below.

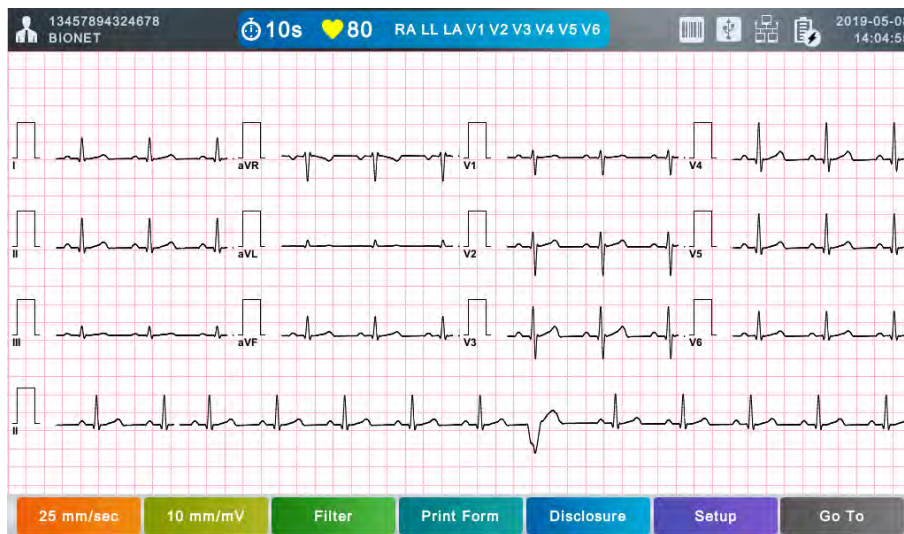

The background color of the screen output of the ECG waveform can be white or black, which you can change in the Setup → ECG → General → Background menu.



In the black background, the waveform is drawn without a grid as shown below.

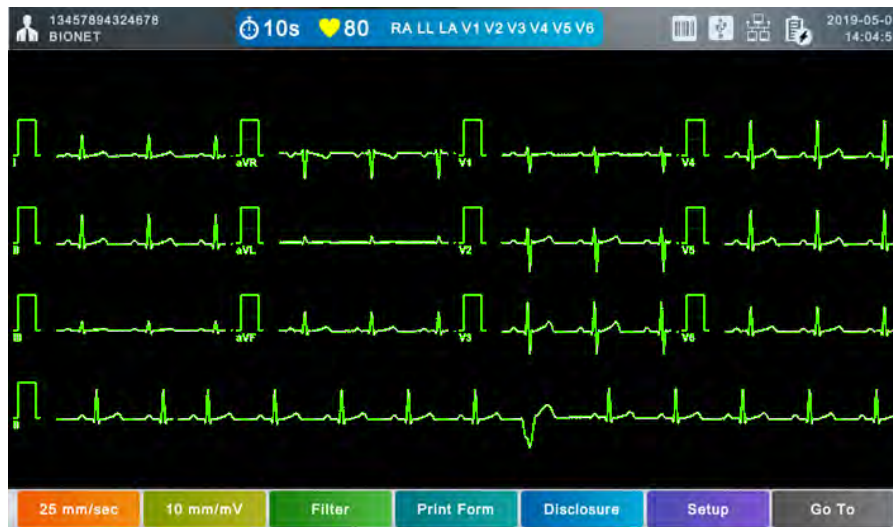

Patient Information

Enter the patient's ID, name, age, gender, height, and weight.

Fields marked with  are required inputs.

Automatic diagnosis is made based on the ECG recording for 10 seconds and is available for pediatrics and adults. It is carried out according to the age of the patient.

Patient Info

ID ✓

Last Name

First Name

Birthday (yyyy-mm-dd) Age years ✓

Gender Male ✓ Department

Height cm Room No.

Weight kg Study Description



Race Asian ✓ Accession No.

Smoke No Referring Physician

Urgent No Pacemaker No

OK Cancel New Re-Exam

Patient ID

Enter a unique number used in the hospital to classify patient medical data. Touch the input field of ID to display the keypad window consisting of alphabets and numbers, and use it to enter patient ID. Touch the  (Caps Lock) key at the bottom left to switch from lowercase to uppercase or vice versa. Touch  (Enter) to save the patient ID. The keypad window disappears.

NOTE

- You cannot use # ' , . / * | : " < > ? characters for ID.
- Use only plain alphabets and numbers for ID. If you enter an ID in Latin extended characters or Russian, an error may occur when you transfer files with the IDs to a PC or USB memory.

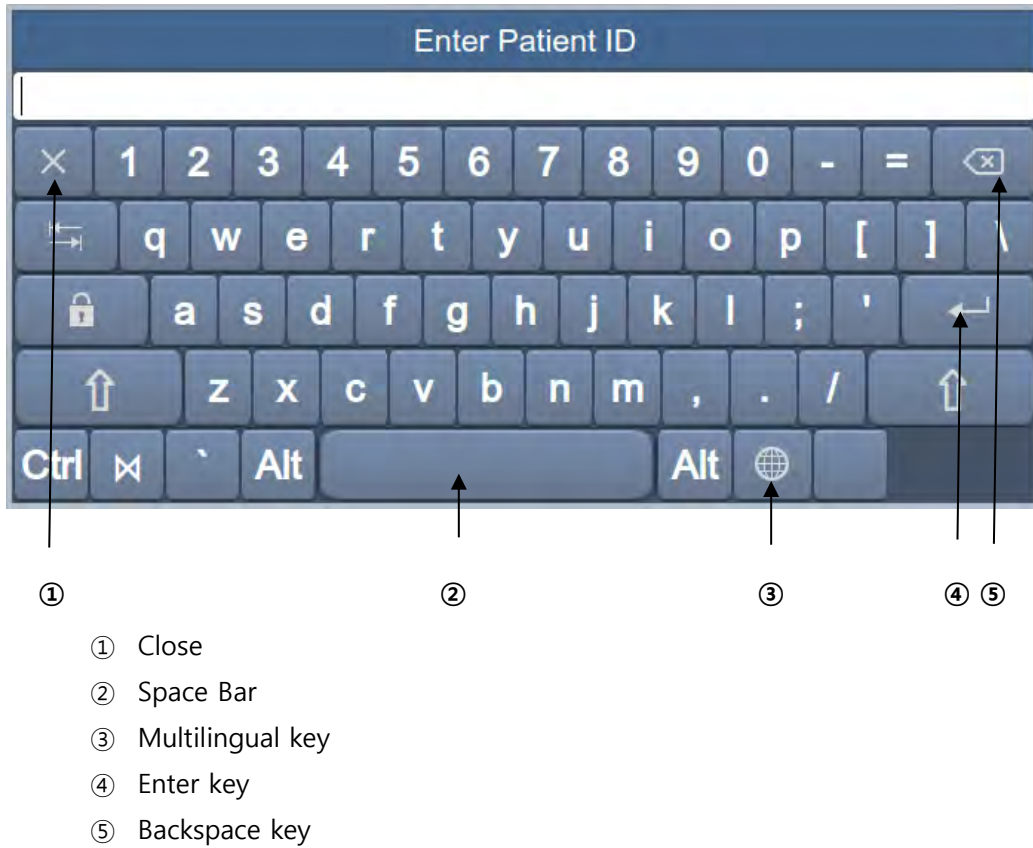

Patient Name

Enter the patient name in the same way as entering the ID.

Date of Birth (Birthday)

Touch the input field of Birthday to display a number pad as below. Enter the patient's date of birth. Patient's age is automatically calculated and entered.

**Age**

Enter the patient's age directly.

Enter the age of pediatrics or adults. Enter the age in weeks or days if you cannot enter the age in years.

NOTE

- Age is automatically calculated when the date of birth is entered.
- If age is not entered, an adult diagnosis is provided.
- If set to the Bionet algorithm, ECG recording will not be performed if you enter an age under 3 years.

Gender

Touch the input field of Gender to select Male or Female.

Height

Enter the patient height in the same way as entering the age.

If the Height Unit is set to inches in System General Setup, enter the height in ft and inches.

Weight

Enter the patient weight in the same way as entering the age.

Race

Enter the race of the patient. There are 3 registered races: Asian, White, and Black.

Touch the input field of Race to select the race type.

Smoking History

Mark whether the patient is smoking.

Urgent

Mark whether the patient needs urgent care.

Pacemaker

Set whether to display the pacemaker position on the RHYTHM or on the diagnosis when a pacemaker signal is detected.

When set to On, pacemaker position is specified; Otherwise, it is not.

NOTE

- Pacemaker is set to Off by default. Set the Pacemaker On only for the patients using it.
- In case of a lead fault, the pacemaker signal may not be detected.

Others

Enter Department, Room No., Study Description, Accession No., Referring Physician in the same way as entering the ID. Set Urgent to Yes for urgent patients and Pacemaker to Yes for pacemaker patients.

Touch [OK] to save the settings or [Cancel] to cancel the settings. Touch [New] to initialize all the patient information you have entered.

Using a Barcode Reader

Place the cursor on each item in the patient information screen and scan the barcode. Information is entered automatically.

When you scan the barcode in the ECG main screen, the patient ID is entered automatically.

Basically, you can use any kind of barcode reader.

However, since the default setting of the entry method of each product may be different, check the method supported by Bionet before using them.

- Entry methods supported by Bionet products: International standard and USB
- The products that have been tested by connecting to Bionet equipment are listed below.

No.	Manufacturer	Product Name	Product Image
1	Symbol	LS-2208	
2	ZEBEX	Z-3110	
3	Honeywell	MS5145	
4	Honeywell	DS2208	

NOTE

<p>Each barcode reader has a product-specific initialization code. Be sure to read the user manual of the product and check the entry method before initializing it.</p>
--

Output Speed

Adjust the width of the output signal for screen output and printout. The available values are 5mm/sec, 12.5 mm/sec, 25mm/sec, 50mm/sec, and 100mm/sec. 25mm/sec means that the ECG signal for 1 second is recorded with a length of 25mm.

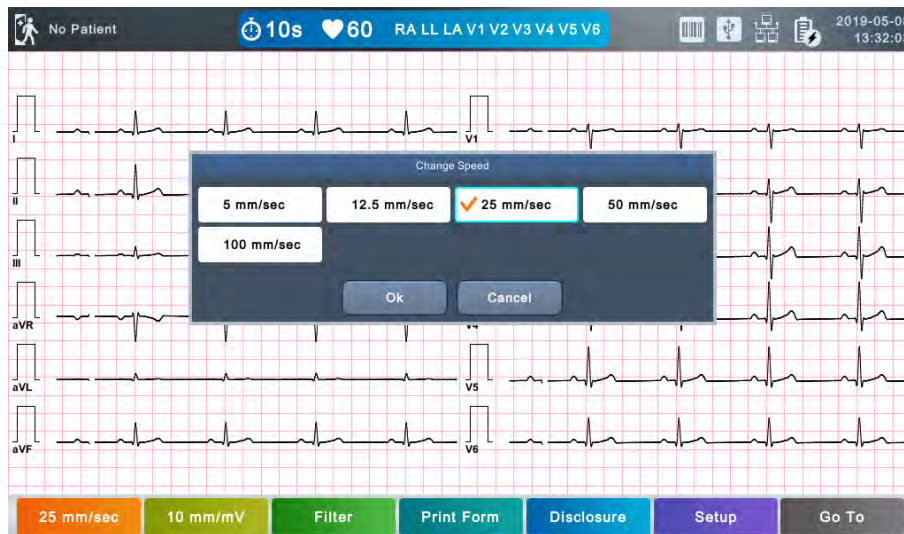

NOTE

- If you set the Rhythm Size of monitoring to Report, the signal is always printed at 25mm/sec regardless of the Output Speed setting.
- When you set the recording mode to 1min, the signal is always printed at 25mm/sec.
- When you set the recording mode to 3, 5, 10, 20 and 30min, the signal is always printed at 12.5mm/sec.

Gain

Adjust the Gain if the size of the output signal is too large to overlap neighboring channels, or it is too small to read deciper.

Settings: - Set the limb leads (I, II, III, aVR, aVL, aVF) and chest leads (V1, V2, V3, V4, V5, V6) to the same value: 2.5mm/mV, 5mm/mV, 10mm/mV, and 20mm/mV.

- Set the limb leads and chest leads to different values: limb leads 10mm/mV / chest leads 5mm/Mv.

10mm/mV means that a signal of 1mV is drawn at a size of 10mm on screen.

Gain is displayed along with the name of each channel on the left side of the LCD screen.

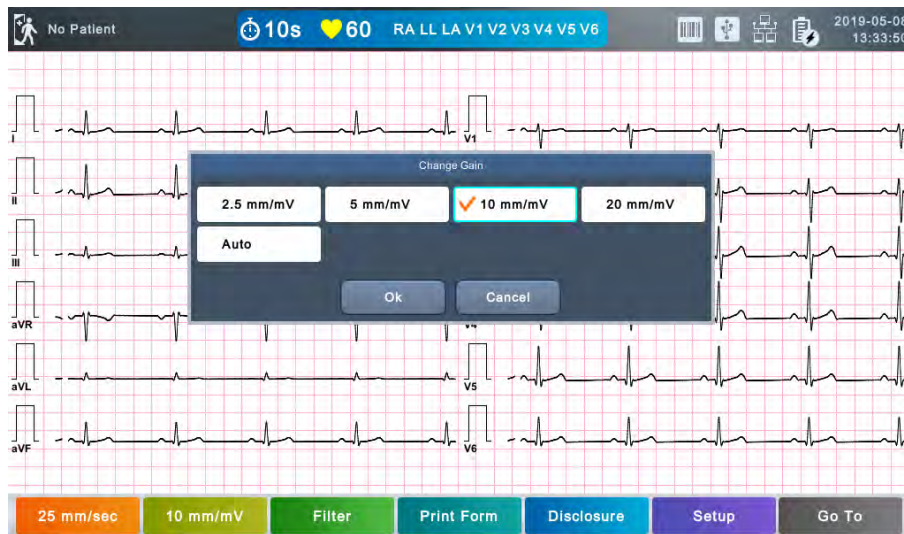

NOTE

When you set the recording mode to 3, 5, 10, 20 and 30min, the printing size is fixed at 5.0mm/mV.

Filter

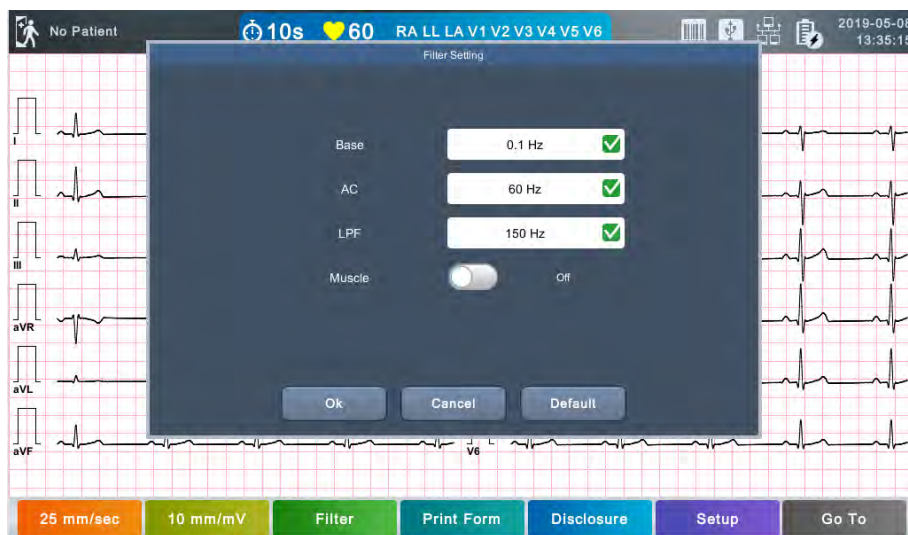

The ECG signal may contain not only ECG data, but also power noise, baseline drift by breathing, and EMG signals. Therefore, proper use of the filter when the signal is bad can give you a good ECG signal.

Baseline drift is the noise occurring from respiration of a patient recording ECG on a huge arc. Baseline filter can be applied as off, 0.05Hz, 0.1Hz and 0.2Hz in the base menu.

The AC filter is a power noise removal filter that can be set to Off, 50 Hz, 60 Hz, and Off means

no power removal. 50 Hz means removing 50 Hz of power noise and 60 Hz of 60 Hz of power noise. 50 Hz is used in Europe and China, and a 60 Hz is used in Korea and the United States. Since power noise is hardly generated with battery power, you can acquire a clear ECG even with filter off when using the battery power.

The LPF filter is a low frequency filter that provides Off, 40 Hz, 100 Hz, 150 Hz, etc. 40 Hz means that all signals above 40 Hz will be removed.

The Muscle filter is a filter for EMG, which is a signal generated from the patient's muscles or organs. Since ECG exam is difficult in patients with particularly high EMG, noise removal is required. Set On to apply the ECG filter, otherwise set to Off. All applied filters are marked in the lower left corner in the Print form.

NOTE

Bionet recommends always using a Baseline Drift filter of 0.1Hz, an AC filter of 50Hz or 60Hz, and an LPF filter of 150Hz. If noise is severe, use an EMG filter appropriately. You can get the best signal by using the recommended filter; otherwise the quality of the signal may become poor.

Print Form

The screenshot shows the 'Print Form Setting' dialog box with the following configurations:

- Record Section:**
 - Form: Panoramic (checked)
 - Beat Form: 3CH+3 (checked)
 - Format: Cabrera (checked)
 - Rhythm CH1: aVR (checked)
 - Rhythm CH2: V1 (checked)
 - Rhythm CH3: V5 (checked)
- Rhythm Section:**
 - Form: 12CH (checked)
 - Size: Continue (checked)

Buttons at the bottom: Ok, Cancel, Default.

Record Form

Set the diagnosis print format.

Print Format	Description
3CH+3	10-second resting ECG recording: I, II, and III in the first 2.5 seconds; aVR, aVL, and aVF in the next 2.5 second; V1, V2, and V3 in the next 2.5 seconds; and V4, V5, and V6 in the next 2.5 seconds. The 3-lead rhythm is recorded at the bottom for 10 seconds.

3CH+1	10-second resting ECG recording: I, II, and III in the first 2.5 seconds; aVR, aVL, and aVF in the next 2.5 second; V1, V2, and V3 in the next 2.5 seconds; and V4, V5, and V6 in the next 2.5 seconds. The 1 lead-rhythm is recorded at the bottom for 10 seconds.
6CH+1	10-second resting ECG recording: I, II, III, aVR, aVL, and aVF in the first 5 seconds; V1, V2, V3, V4, V5, and V6 in the next 5 seconds. The 1 lead-rhythm is recorded at the bottom for 10 seconds.
12CH	The 12-lead rhythm is recorded simultaneously for 10 seconds in the order of I, II, III, aVR, aVL, aVF, V1, V2, V3, V4, V5, and V6.
1CH+3	Rhythms I, II, III, aVR, aVL, aVF, V1, V2, V3, V4, V5, V6 are recorded for 0.83 seconds each, and a 3-lead rhythm is recorded for 10 seconds at the bottom.

Rhythm Channel (Rhythm CH1, Rhythm CH2, and Rhythm CH3)

Set the rhythm-representative lead used in the 3CH+3, 3CH+1, 6CH+1, 6CH+1 (ST), 1CH+3 form for diagnosis printout. The 3CH+3 setting uses all 3 selected values, and only the first value is used for the 3CH+1 and 6CH+1 settings.

By default, it is set to II, V1, and V5. As for 3CH+1, 6CH+1, and 6CH+1 (ST), II is used. All II, V1, and V5 are all used for 3CH+3.

Beat Form

Select between Text, Guide, and Vector as additional print form after a diagnosis is printed.

Printing speed is fixed at 50mm/sec regardless of the Output Speed setting.

Print Format	Description
Text	A representative beat and each diagnostic parameters are printed.
Guide	The representative beat and each diagnostic parameter are printed, along with a diagnostic guide for arrhythmia.
Vector	The representative beat and each diagnostic parameters are printed, marking QRS Vector with an arrow.

Presentation Format

Set the presentation format of 12-lead ECG.

Presentation	Description
--------------	-------------

Format	
Standard	12-lead ECG is presented in the standard order: Leads I, II, III, aVR, aVL, aVF, V1,V2,V3,V4,V5 and V6.
Cabrera	12-lead ECG is presented in the Cabrera order: Leads aVL, I, -aVR, II, aVF, III, V1,V2,V3,V4,V5 and V6.

Rhythm Form

Set the real-time printout form.

Print Format	Description
3CH	3 leads are printed simultaneously. I, II, and III are printed first, and to change the printing lead, press the RHYTHM key on the control panel again. Each time you press the [RHYTHM] key, the sequence changes to I~III → aVR~aVF → V1~V3 → V4~V6 → I~III, and so on.
6CH	6 leads are printed simultaneously. I~ aVF are printed first, and to change the printing lead, press the [RHYTHM] key on the control panel again. Each time you press the [RHYTHM] key, the sequence changes to I~aVF → V1~V6 → I~aVF, and so on.
12CH	12 leads are printed simultaneously.

NOTE

To change the printing lead with the RHYTHM key in 3CH and 6CH settings, the Rhythm Size must be set to Continue.

Rhythm Report (Rhythm Size)

Sets the report size of the real-time print.

- Report: About 10 seconds of data are printed in Report format.
- Continue: The pre-set lead is continuously printed until you press the [ESC] key on the control panel.

NOTE

When Rhythm Size is set to Report, the printing speed is fixed at 25.0mm/sec.

The followings are examples of print formats:

Rhythm Print Format (3CH)

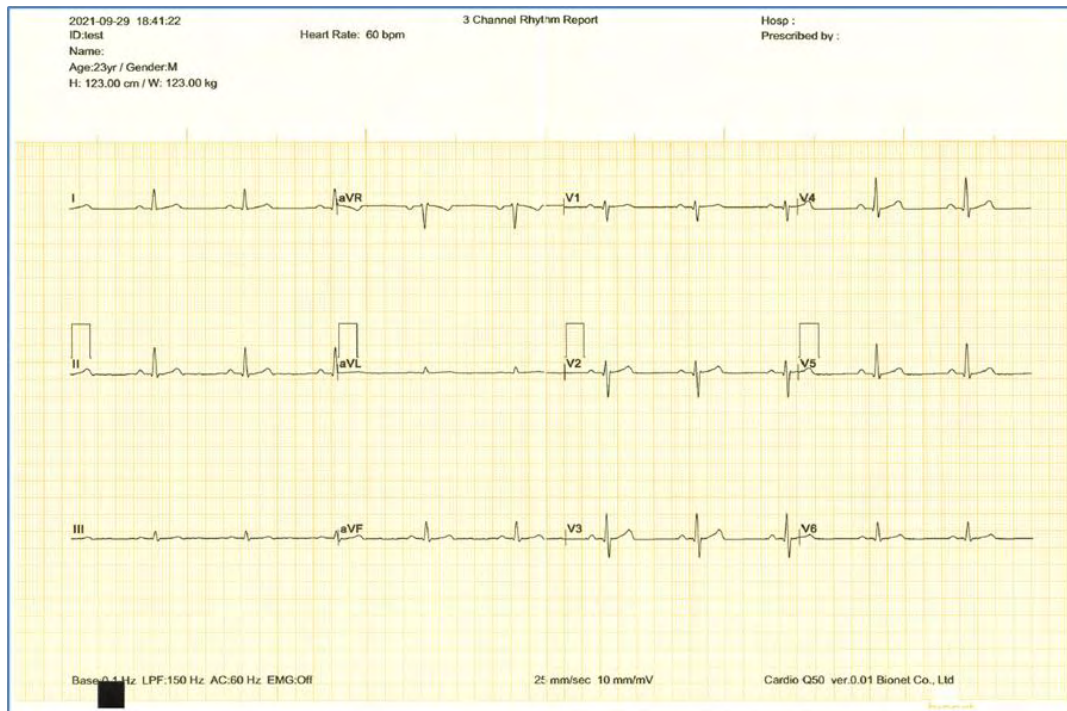

Rhythm Print Format (6CH)

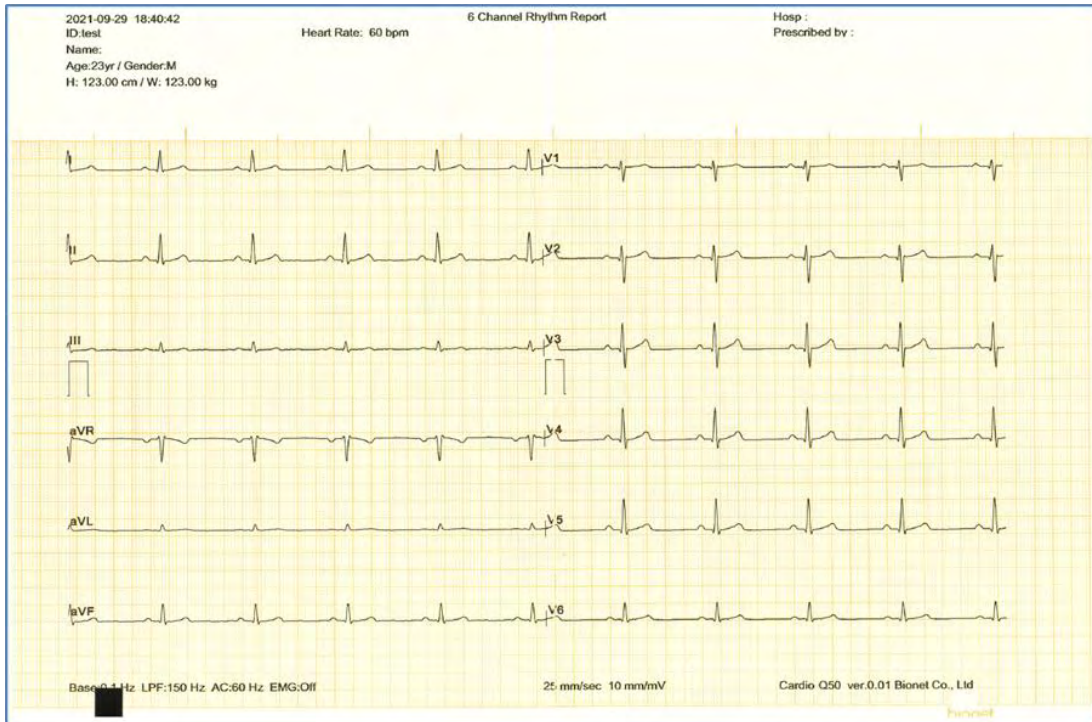

Rhythm Print Format (12CH)

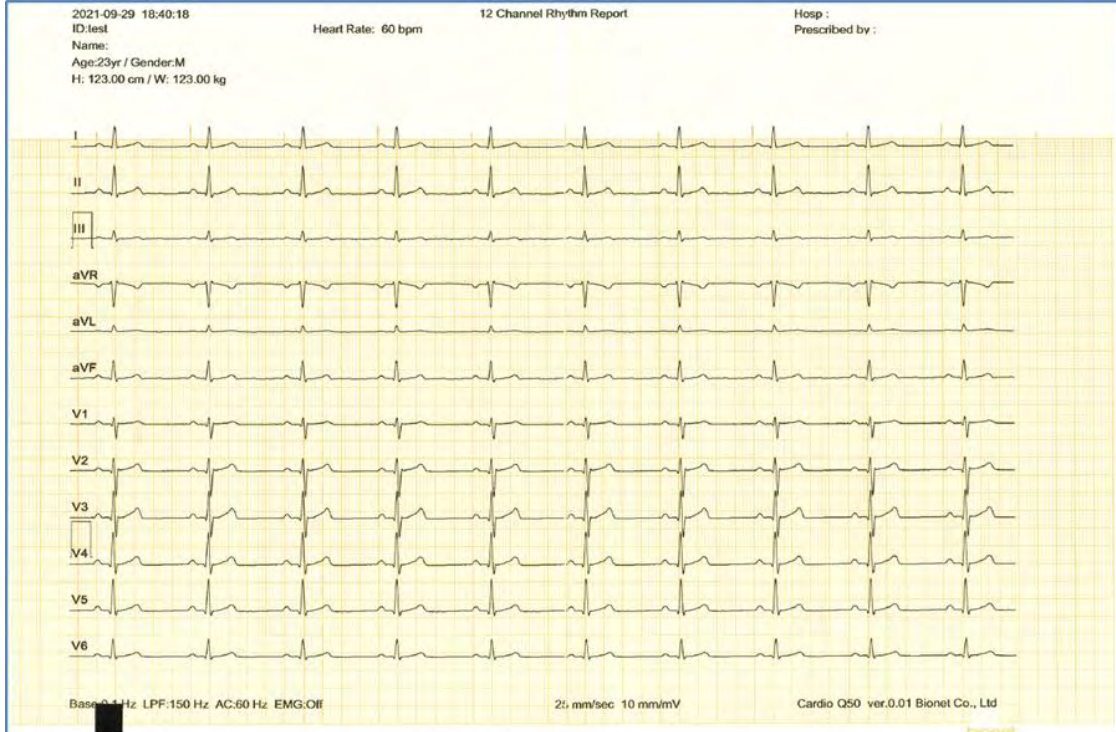

Diagnosis Print Format (3CH + 3RHY)

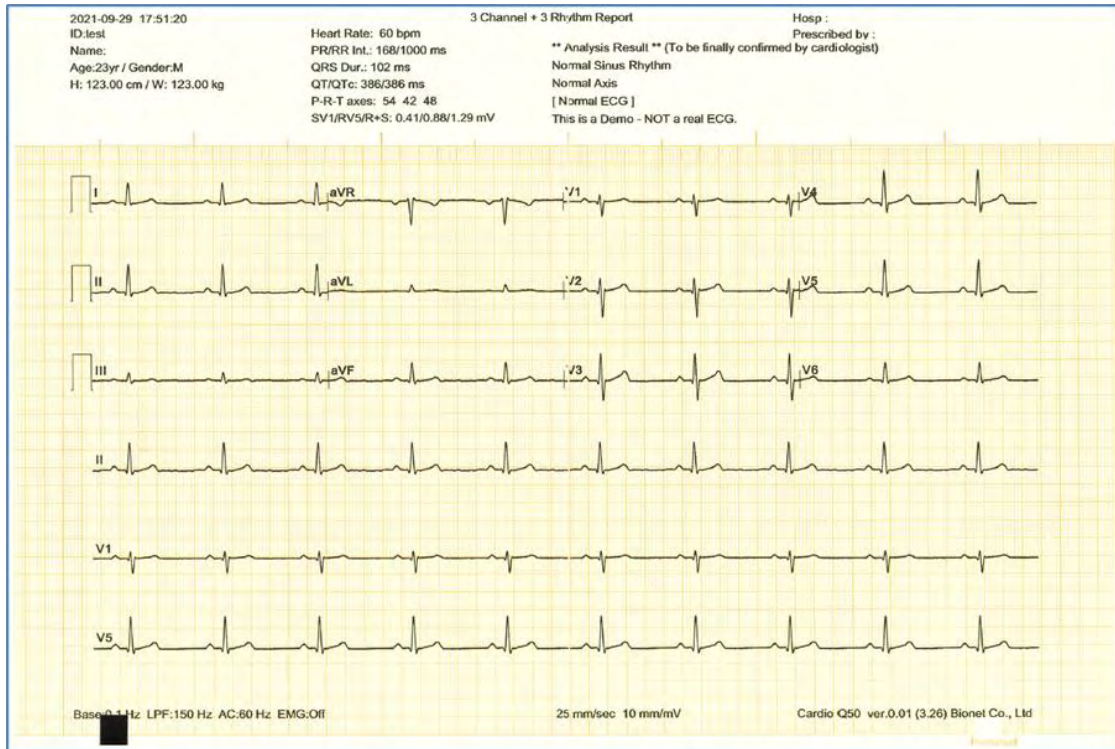

Diagnosis Print Format (3CH + 1RHY)

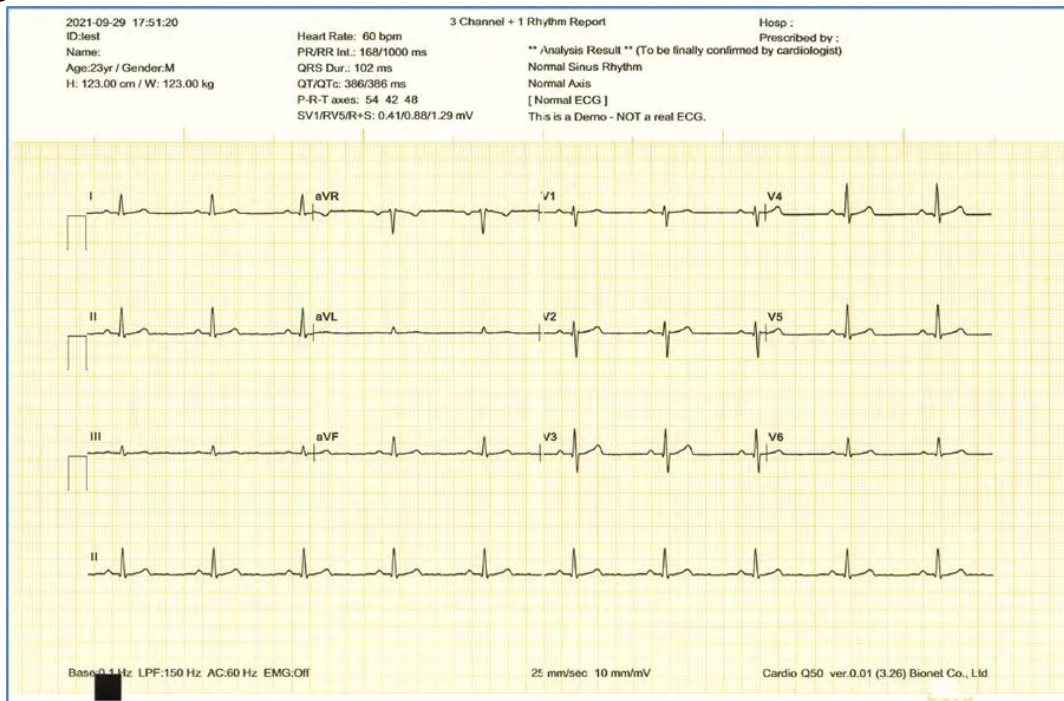

Diagnosis Print Format (6CH + 1RHY)

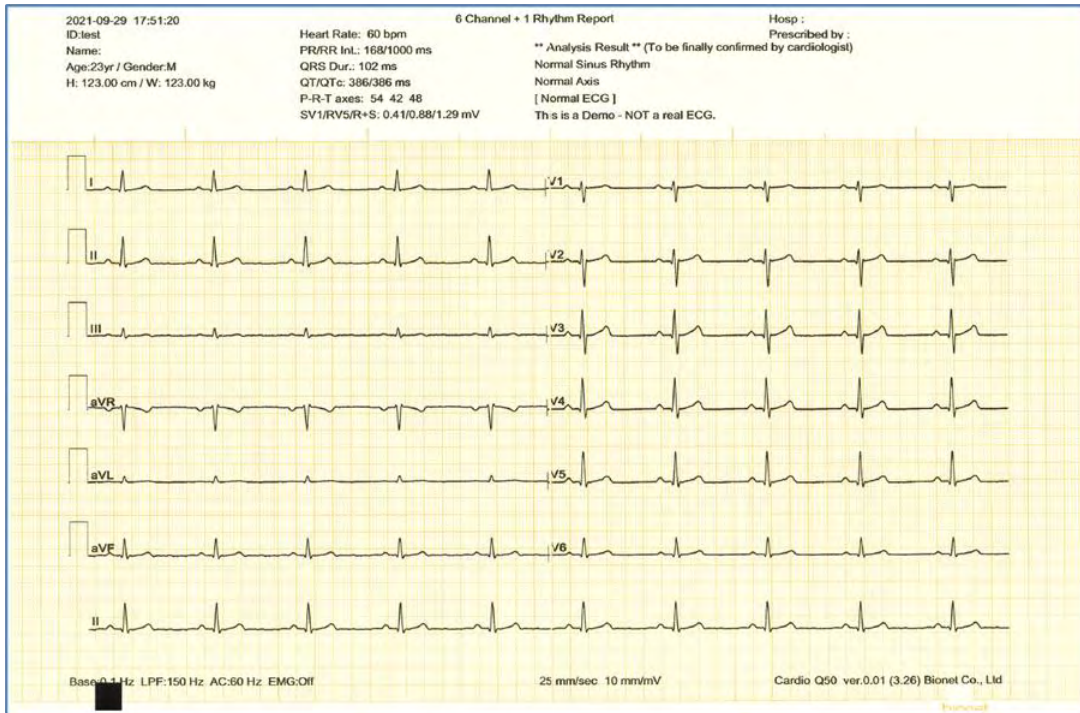

Diagnosis Print Format (12CH)

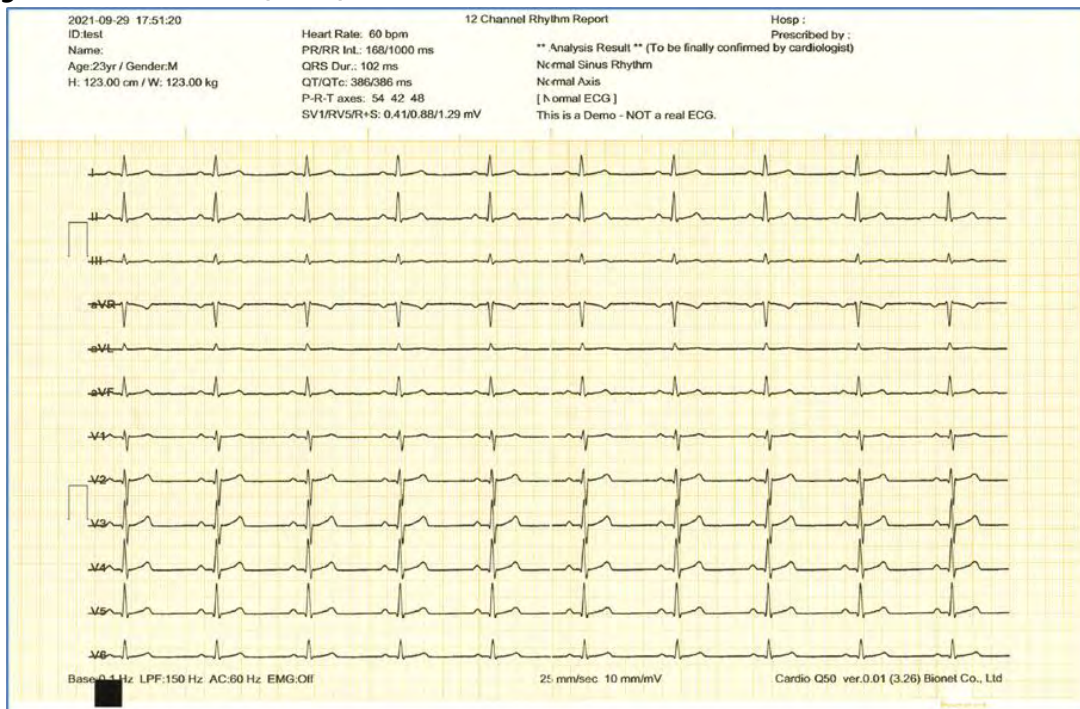

Record Report Form (1CH +3)

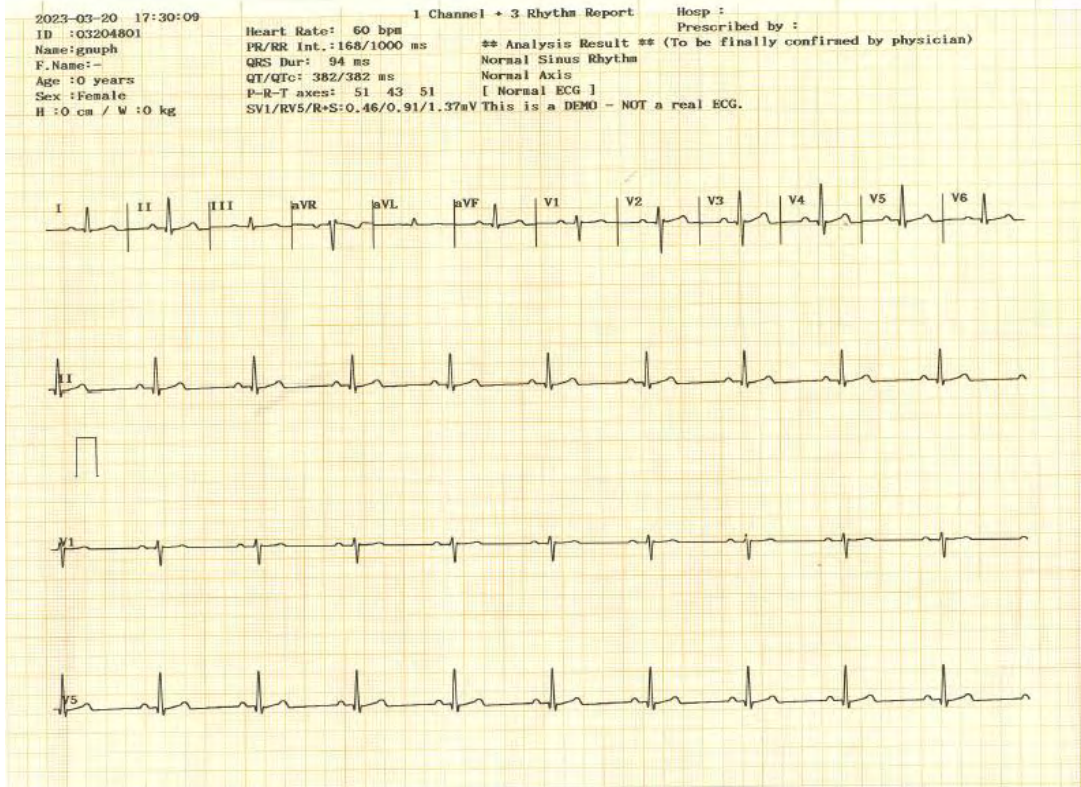

Record Report Form (Cabrera Report)

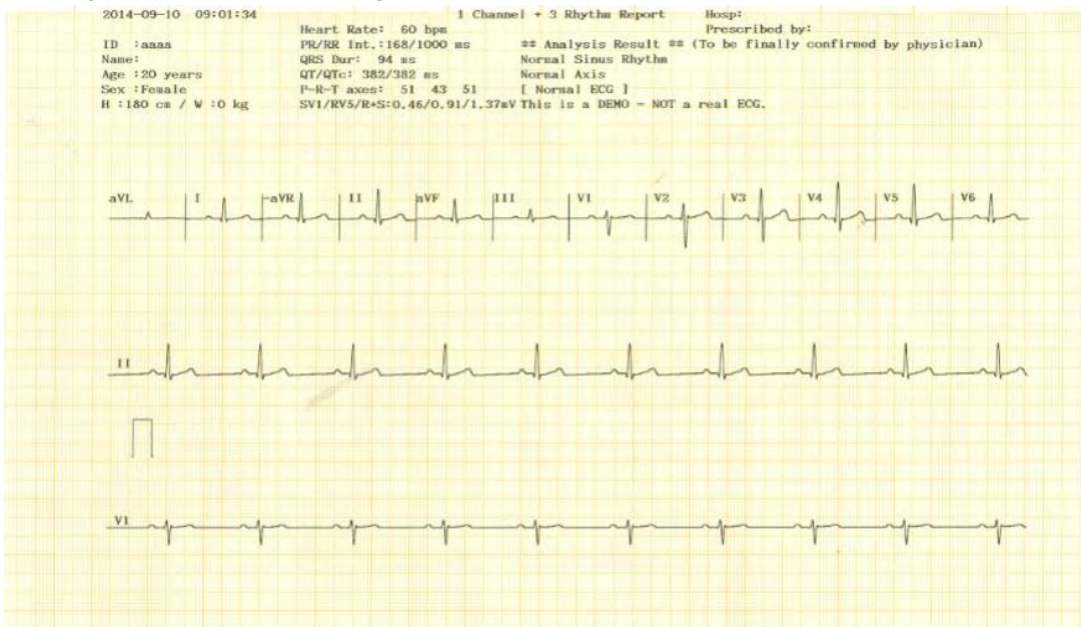

Diagnosis Print Format (BEAT REPORT-TEXT)

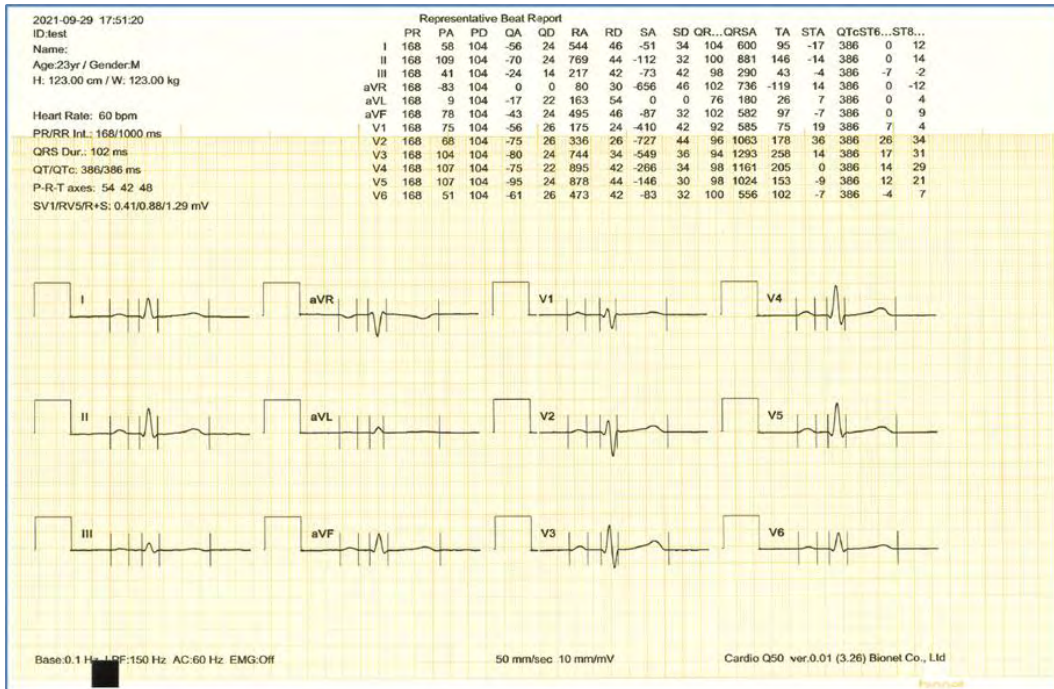

Diagnosis Print Format (BEAT REPORT-VECTOR)

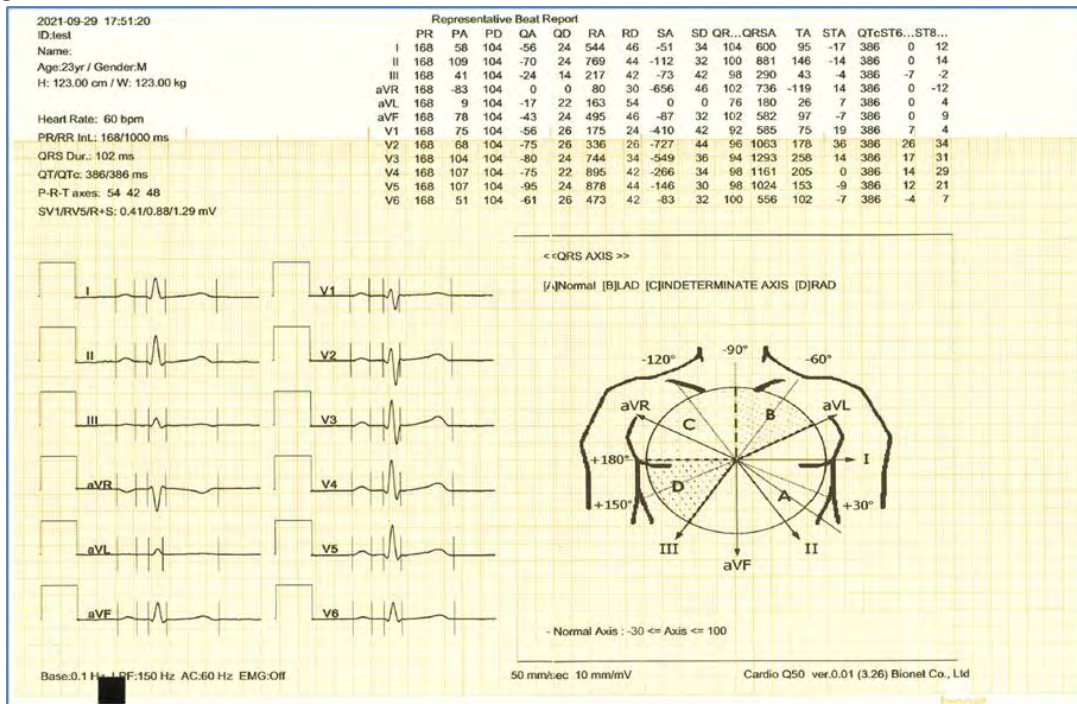

Diagnosis Print Format (BEAT REPORT-GUIDE)

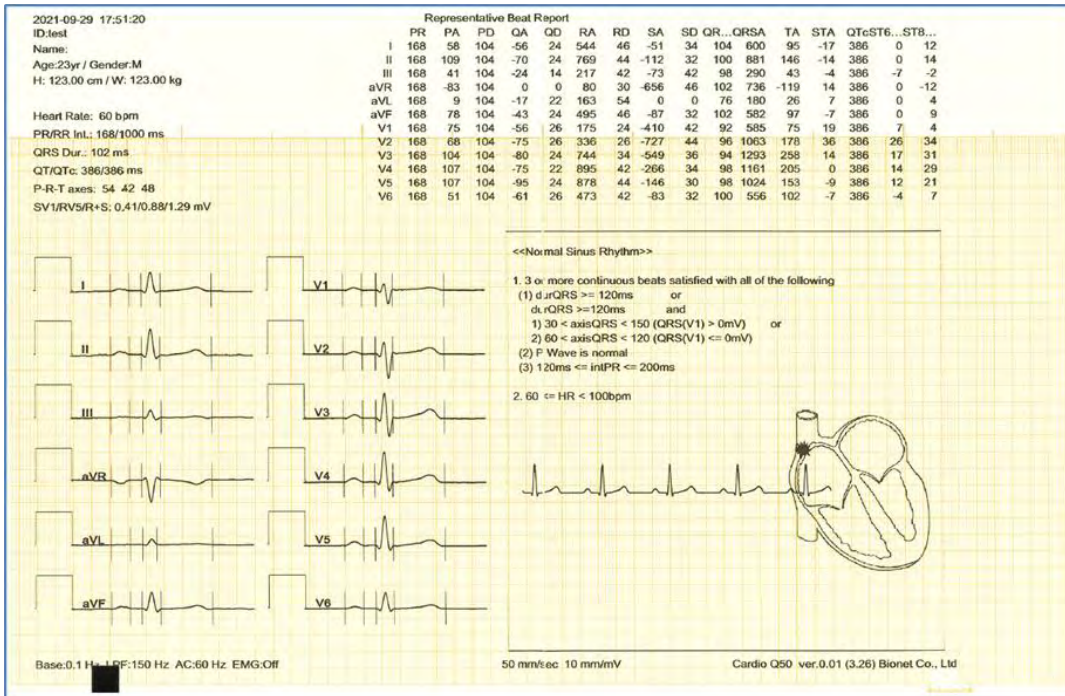

* **Explanation of BEAT REPORT Variables**

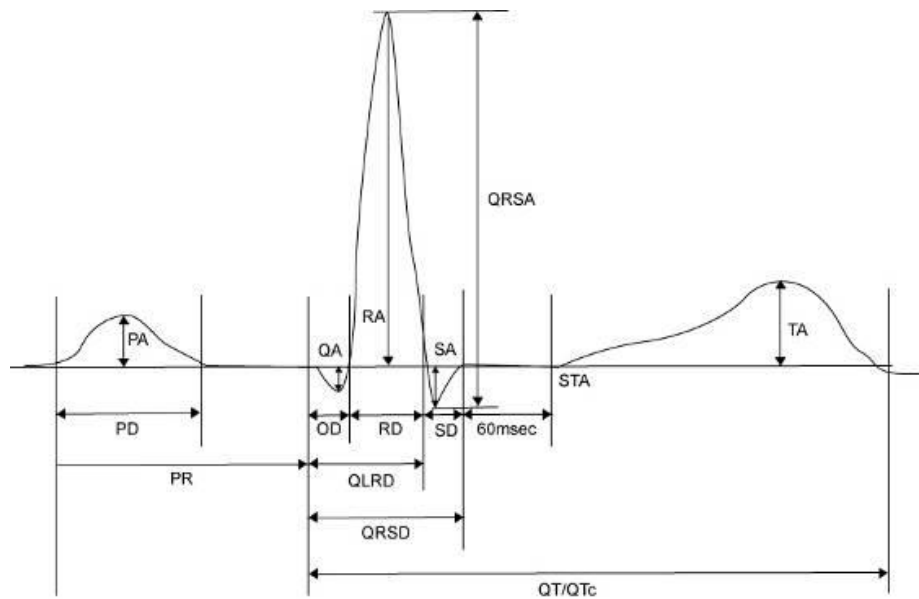

- PR: PR Interval
- PA: Amplitude of P Wave (P Amplitude)
- PD: Duration of P Wave (P Duration)
- QA: Amplitude of Q Wave (Q Amplitude)
- QD: Duration of Q Wave (Q Duration)
- RA: Amplitude of R Wave (R Amplitude)
- RD: Duration of R Wave (R Duration)
- SA: Amplitude of S Wave (S Amplitude)
- SD: Duration of S Wave (S Duration)
- QRSD: Duration of QRS Wave (QRS Duration)
- QRSA: Amplitude of QRS Wave (QRS Amplitude)
- TA: Amplitude of T Wave (T Amplitude)
- STA: Amplitude of ST Wave (ST Amplitude)
- QTc: Correct Q-T Interval (collect Q-T Interval)
- ST60A: Amplitude of ST+60ms (ST60ms Amplitude)
- ST80A: Amplitude of ST+80ms (ST80ms Amplitude)

NOTE

The unit of parameter intervals (duration, interval) used in the Beat Report is *ms*, and the unit of height (amplitude) is *uV*.

NOTE**Dextrocardia**

Normally, the heart is located in the left chest. However, there are cases where the heart is located in the right chest, which is called Dextrocardia.

You may suspect Dextrocardia in the following cases:

- If P, QRS and T are all reversed in Lead I
- If aVR and aVL are switched, and lead II and III are switched
- If R wave becomes smaller from V1 to V6 in chest lead

For Dextrocardia patients, change the electrode positions and measure as follows to obtain automatic diagnostic results correctly.

- Switch the electrodes on right hand (R) and left hand (L).
- Attach the chest lead from the left in order, which used to be attached from the right.

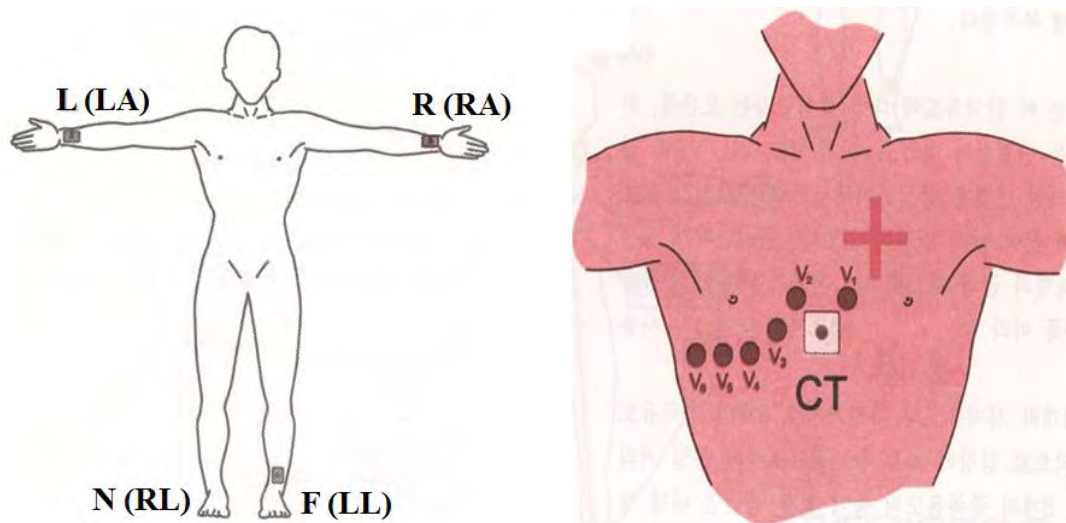

5) Disclosure

Touch the  button on the menu bar at the bottom of the ECG main screen to switch to Disclosure screen. Disclosure is a function that stores ECG data in the equipment memory and shows it when executed.

In the Disclosure screen: The pre-stored 30 minutes of ECG data are displayed in 1CH. The interval section of the pre-set mode (10 seconds, 1 minute, 3 minutes, 5 minutes, 10 minutes, 20 minutes, or 30 minutes) is marked with a square, allowing you to print diagnosis for the selected area or transmit data of the area.

Touch the graph window and select the screen output section: your touch point becomes the center of the square-marked area. Select the screen output section and press the [AUTO] key on the control panel to print diagnosis or save and transmit the data.

Refer to the following description for Disclosure screen.

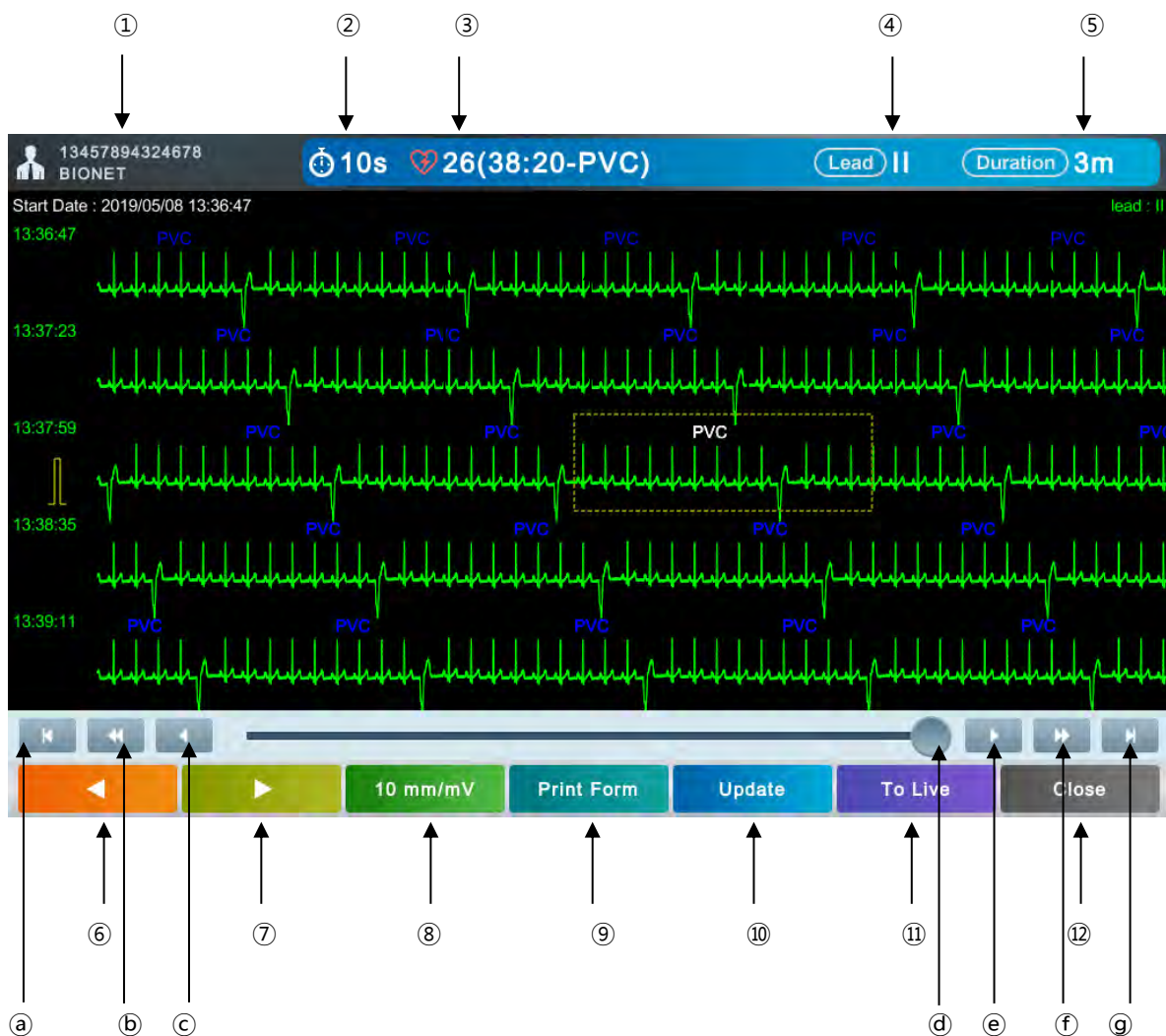

- ① Patient ID and name: Touch this button to enter patient information.

- ② ECG recording mode (10s, 1m, 3m, 5m, 10m, 20m, or 30m): Touch this button to set a mode.
- ③ Number of events (Arrhythmia): Touch this button to set Event List (Arrhythmia History).
- ④ Lead: Touch this button to select a lead.
- ⑤ Duration of ECG Wave: Touch this button to set a duration.
- ⑥ Go to Previous event (Arrhythmia).
- ⑦ Go to Next event (Arrhythmia).
- ⑧ Gain of ECG waveform: Touch this button to set gain.
- ⑨ Touch this button to set an output form for screen output and printout.
- ⑩ Touch the button to update EKG Wave data from the start of Disclosure to the present time.
- ⑪ Touch this button to switch to Live mode.
- ⑫ Close the screen.
- Ⓐ Go to the first page of the Disclosure screen.
- Ⓑ Go to previous page of the Disclosure screen.
- Ⓒ Go to previous line in the Disclosure screen.
- Ⓓ Slide the graph.
- Ⓔ Go to next line in the Disclosure screen.
- Ⓕ Go to next page of the Disclosure screen.
- Ⓖ Go to last page of the Disclosure screen.

Refer to the following description for Disclosure Live mode screen.

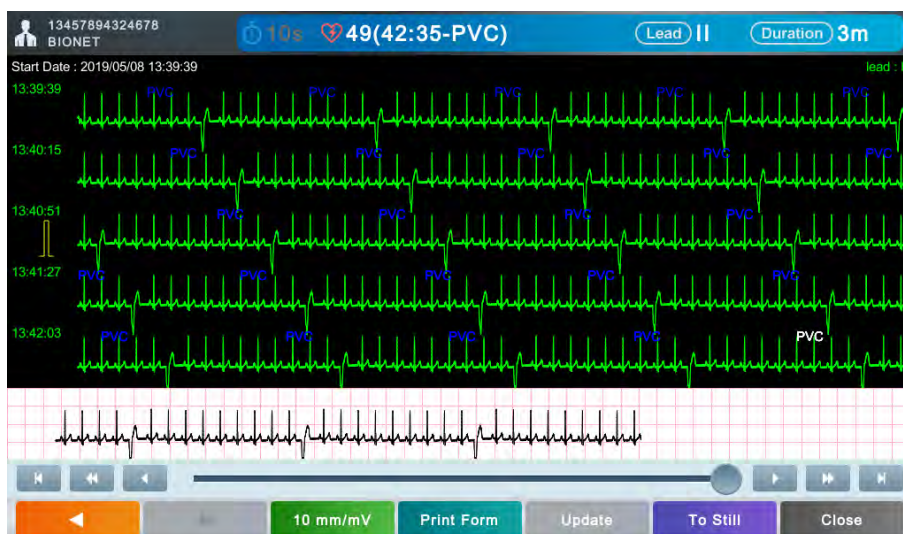

ECG Wave data is drawn in real time in the grid-marked area at the bottom of the screen.

The abbreviation of the diagnosis name displayed on the screen is as follows:

No.	Abbreviations	Diagnosis
1	Bigeminy	PVC Bigeminy
2	Trigeminy	PVC Trigeminy
3	Couplet	PVC Couplet
4	ShortRun	Short run of PVC
5	Vtachy	Ventricular Tachycardia
6	Vrhythm	Ventricular Rhythm
7	Vbrady	Ventricular Bradycardia
8	Paced	Pacemaker Rhythm
9	PVC	PVC
10	Asystole	Asystole
11	Pause	Pause
12	Irregular	Irregular
13	RonT	RonT

Arrhythmia Template

No.	Diagnosis	Description
1	PVC Bigeminy	Occurs when two or more bigeminal cycles (a ventricular beat followed by a non-ventricular beat) are detected.
2	PVC Trigeminy	Occurs when two or more trigeminal cycles (a ventricular beat followed by two non-Ventricular beats) are detected.
3	PVC Couplet	Occurs when two ventricular beats are detected and have non-ventricular beats before and after the couplet. The coupling interval must be less than 600 milliseconds.
4	Short run of PVC	Occurs 3~5 continuous Ventricular Premature Beats.
5	Ventricular Tachycardia	Occurs when six or more ventricular beats are detected when the average heart rate is greater than or equal to 100 beats per minute.
6	Ventricular Rhythm	Occurs when six or more ventricular beats are detected with an average heart rate for the ventricular beat between 50 and 100 beats per minute.
7	Ventricular Bradycardia	Occurs when a run of three or more ventricular beats is detected with an average heart rate that is less than or equal to 50 beats per minute.
8	Pacemaker Rhythm	A pacemaker is indicated when electrical impulse conduction or formation is dangerously disturbed. It shows pacemaker spikes:

		vertical signals that represent the electrical activity of the pacemaker.
9	PVC	Isolated premature ventricular complexes occur when a premature ventricular beat is. Detected and has non-ventricular beats before and after.
10	Asystole	Ventricular asystole occurs whenever the displayed heart rate drops to zero.
11	Pause	Occurs when the interval between two consecutive beats exceeds three seconds.
12	Irregular	Occurs when six consecutive normal R-to-R intervals vary by 100 milliseconds or more.
13	RonT	Occurs when a ventricular complex is detected within the repolarization period of a Non-ventricular beat.

NOTE

The diagnosis provided by Cardio Q50 / Cardio Q70 must be confirmed by a qualified medical professional.

6) Real-time Printing (RHYTHM Key)

Press the [RHYTHM] key on the control panel to print the ECG signal in real-time.

You can set the output speed of Rhythm among 5mm/sec, 12.5mm/sec, 25mm/sec, and 50mm/sec. For Gain, you can set among 2.5mm/mV, 5mm/mV, 10mm/mV, 20mm/mV, and auto.

Set the print form to 3CH, 6CH, or 12CH.

When you press the [RHYTHM] key on the control panel, the message "Rhythm" is displayed on the screen and the printing starts according to the set speed.

- 3CH printing: 3 channels are printed simultaneously. (I ~ III / aVR ~ aVF / V1 ~ V3 / V4 ~ V6)
To change the channel, press the [RHYTHM] key on the control panel again.
- 6CH printing: 6 channels are printed simultaneously. (I ~ aVF / V1 ~ V6) To change the channel, press the [RHYTHM] key on the control panel again.
- 12CH printing: 12 channels are printed simultaneously. (I ~ V6)

Press the [ESC] key on the control panel to stop the printing.

NOTE

Real-time printing is supported up to 50mm/sec.

NOTE

Do not attempt to attach or detach a USB device while the printer is working as it may cause the printer module to rattle.

7) One-key Diagnosis (AUTO key)

Press the [AUTO] key shortly to diagnose the ECG acquired during the set duration, and to save, transmit, and print the result. It functions according to the [AUTO] key settings set in System General Setup.

Press and hold the [AUTO] key longer than 3 seconds to diagnose the ECG acquired during the set duration and to print the result.

Setting Diagnostic Mode

Touch  (Mode Change button) at the top center of the ECG main screen. Set the duration to acquire ECG data for diagnosis.

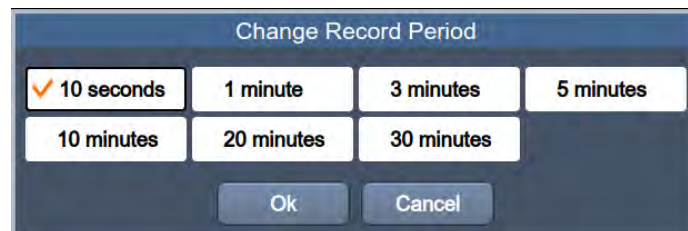

Recording ECG for 10 seconds

Press the [AUTO] key on the control panel to acquire ECG for 10 seconds. A timer is shown on the top.

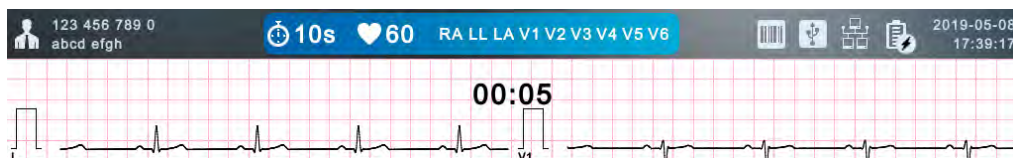

Automatic diagnosis is made based on the 10-second resting ECG, and the preview screen appears as follows.

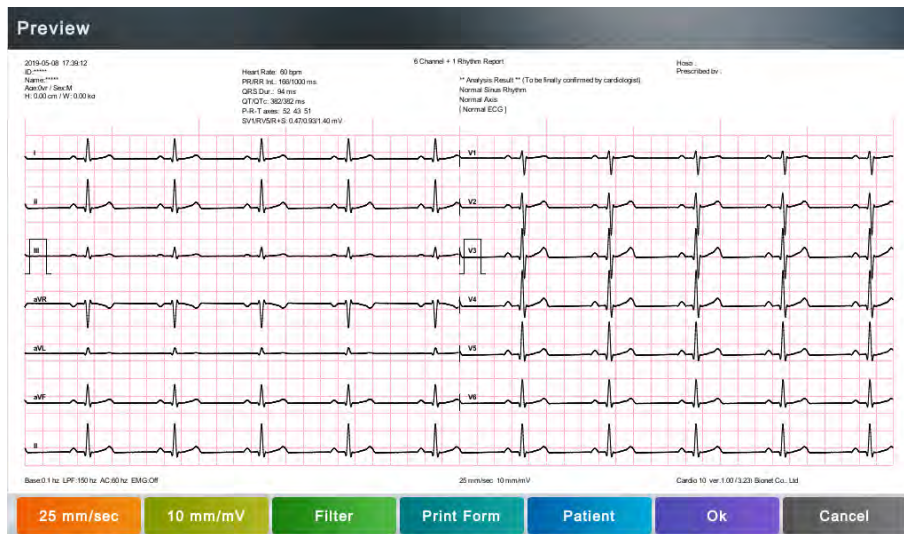

Touch [OK] if the data is reliable.

NOTE

Set Preview settings in Setup → ECG → Record → Preview.

Recording Long-term ECG

Touch the ECG recording mode at the top of the ECG main screen and set the duration to 1, 3, 5, 10, 20 or 30 minutes.

Press the [AUTO] key on the control panel to measure in the same way as the 10-second resting ECG recording.

NOTE

- Automatic diagnosis performs automatic ECG interpretation using the parameter values detected in P, QRS, and T waves of the acquired ECG waveform. The analysis results may not be consistent with the doctor's judgment.
- Automatic diagnosis is used only for the purpose of improving the reliability and accuracy of diagnosis during medical treatment, and the overall judgment must be made by a medical professional by integrating analysis results, clinical results, and other test results.

8) Printing Diagnostic Copy (COPY key)

You can reprint the saved data with the same settings as before, or print it by changing its settings of Filter, Gain, Output Speed, Channel Configuration, Rhythm, etc.

When the diagnosis is issued, press the [COPY] key on the control panel to print a report with the changed settings applied to the saved data.

NOTE

You cannot use COPY key function if you change the diagnosis mode after a diagnosis is issued.

9) System Settings

Set up various items related to the equipment in the Setup menu.

The top menu bar has a network icon and date/time button, and the bottom menu bar has a Setup button to configure the equipment settings.

NOTE

Long sentences may be partially displayed depending on the language.

A ※ symbol is displayed in front of a partial sentence. Touch it to read the full sentence.

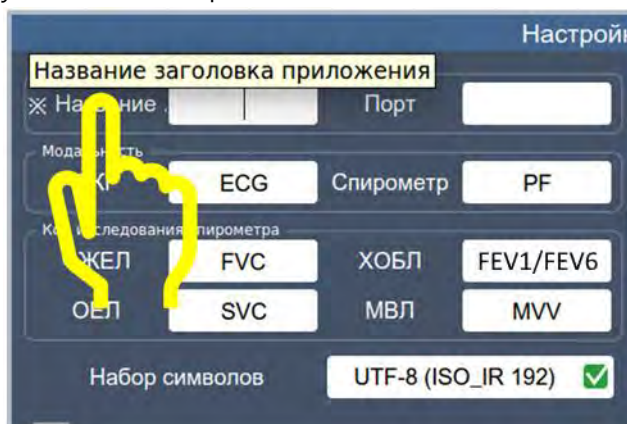

Setting Date and Time

There is a system date and time area at the right end of the top menu bar of the ECG main screen. Touch it to set the system date and time.

Touch [OK] to confirm the Set Value.



NOTE

- If any of Year, Month, Day, Hour, or Minute are changed in the Date and Time Settings, the Second value is automatically initialized to 00, which cannot be set arbitrarily.
- If the system date and time are changed, all Disclosure Data recorded in the equipment will be deleted.

Setting Network

Set the network information to allow the equipment to interface with an external PC over the network. Set the IP on the network. DNS settings are not necessary.

Touch  (Network button) on the right side of the menu bar of the ECG main screen.

DHCP

Check the DHCP box: the Device IP, Subnet Mask, and Gateway IP values are automatically set.

Device IP, Subnet Mask, Gateway IP

If you don't check the DHCP box, you have to set Device IP, Subnet Mask and Gateway IP manually.

Touch the input field of each item to load the keypad window, and enter the setting value.

NOTE

When manually entering values, you must enter the value assigned by the person in charge of computerization so that the Device IPs do not overlap with those of other devices.

NOTE

To connect to the PACS server, you must enter the Device IP manually. If the IP is set to DHCP, the device IP may change every time the device is turned on. If the changed IP is different from the device IP registered in the PACS server, server connection may not be made.

Setting Wireless Network

Plug a USB wireless LAN card into the USB port of Cardio Q50 / Cardio Q70 to set up the wireless network.

Wireless

Select Wired or Wireless for network connection.



Set wireless connection to On.



AP Search

Set up a wireless network connection.



Touch [AP Search]. The setting screen appears as shown below.



Button	Description
	AP Re-search
	Go to Previous page/Next page

	Connect to the selected AP
	Network Setup Screen

How To Connect

1. Select an AP to connect to.
2. Touch [Connect]. To connect to an AP marked with a padlock mark, enter the security key.
3. If the connection is successful, the network icon at the top right of the screen changes to  (wireless icon), otherwise it is displayed as  (no connection).

Supported USB Wi-Fi Dongle

USB Wi-Fi dongles supported by Cardio Q50 are as follows:

Model	USB VID:PID	chipset
TP-LINK Archer T2U AC600	2357:011F	Realtek MT7610U

In addition, you can use the USB Wi-Fi dongles using the chipsets below.

chipset
MediaTek 7650u / 7610u
Ralink 7601U
Realtek 3070
Realtek 5370
Realtek 8188CU/8192CU
Realtek 8188EUS
Realtek 8821a
MediaTek 7650u
Ralink 7610u

NOTE

Use an internationally certified Wi-Fi dongle. Bionet does not manufacture or provide Wi-Fi dongles. You can use any Wi-Fi dongle using one of the 9 chipsets listed above. The Wi-Fi dongle that Bionet tested as a representative model is T2U AC600, which is widely used and internationally certified.

CAUTION

It may take up to 15 seconds for the Wi-Fi dongle to be connected to the equipment and recognized.

At this time, do not remove the dongle as it may not work properly.

NOTE

Search for an AP and set up a security key to use a wireless network.

If the AP to connect to does not require authentication, you are automatically connected with no need to enter the security key.

Automatically connected APs without security keys do not guarantee communication security.

NOTE

Bionet recommends using English alphabet to name the wireless network (SSID) of the AP. Inputs in Korean or other languages can be shown broken or as strange characters.

NOTE

- When using a general AP, it is recommended to connect up to 8 devices to the same network.
- Due to the nature of wireless connection, connection may not be stable depending on the environment.

Setting the ECG

Touch [Setup] on the lower menu bar of the ECG main screen to change the settings. You can set ECG-related settings for each group.

Touch [Default] to enter default values for each input field in the current screen, and touch [OK] to save the settings or [Cancel] to cancel the settings.

Setting ECG-General



Filter

Refer to the Filter section described earlier in the manual.

Gain

Refer to the Gain section described earlier in the manual.

Speed

Refer to the Output Speed section described earlier in the manual.

Display Form

Set the display form of the ECG waveform drawn on the ECG main screen.

Type	Description
6X2	6 channels are drawn simultaneously in 2 columns. (I ~ aVF / V1 ~ V6)
3X4+1	3 channels are drawn simultaneously in 4 columns, and 1 rhythm channel is drawn in the last line. (I ~ III / aVR ~ aVF / V1 ~ V3 / V4 ~ V6)

Demo

Enable or disable the demo feature. When the Demo is set to On, a 60bpm Sinus Normal Rhythm signal is displayed on the screen, with DEMO indicated in the center. You can test all functions such as rhythm, diagnosis, copying, and network.

To cancel the Demo, turn off and on the equipment.

Setting the Lead Fault

A lead fault may occur if the lead connection of the patient cable is unstable. Set whether or not to display the Lead Fault message in this case.

Set it to On to show a Lead Fault message or Off not to.

Lead Fault message is displayed at the top center of the ECG Main screen as follows.

RA LL LA V1 V2 V3 V4 V5 V6

NOTE

- If RA Lead is faulted, no waveform is displayed.
- If LA Lead is faulted, waveforms of I and V1 ~ V6 Leads are not displayed.
- If RL Lead is faulted, Lead Fault does not appear and waveforms of all Leads can be displayed.
- If LL Lead is faulted, waveforms of II and V1 ~ V6 Leads are not displayed.
- If a lead fault occurs during monitoring or recording, a message is displayed with a beep.
- When a lead fault occurs, the pacemaker signal may not be detected. As it may affect the diagnosis, measure ECG again if a lead fault occurs.

Background Color

A lead fault may occur if the lead connection of the patient cable is unstable. Set whether or not to display the Lead Fault message in this case.

Set it to On to show a Lead Fault message or Off not to.

Lead Fault message is displayed at the top center of the ECG Main screen as follows.

QRS Sound Setup

In this menu, users can set the device to ring an alarm sound when a QRS beat has generated while it is in waiting mode. Users can either set the alarm ON or OFF by selecting the menu with ON turning on and OFF turning off the alarm sound.

Note

No sound will ring while printing even when the QRS sound is set to ON.

Setting ECG Recording

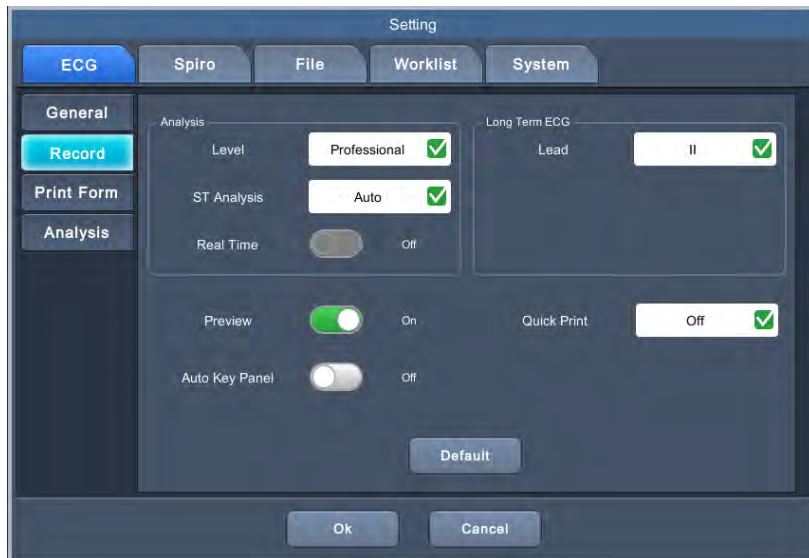

Analysis

Level

Set the Automatic Diagnosis level of the 10-second recording.

Basic level: Provides only serious diagnoses with the diagnostic criteria value is raised.

Professional level: Various diagnoses are provided according to the standard diagnosis criteria.

ST Analysis

Set the ST Segment diagnosis during automatic diagnosis on 10-second recording.

AUTO: The J Point related to ST Level is automatically set.

60msec: J Point is set to 60msec point.

80msec: The J Point is set to the 80msec point.

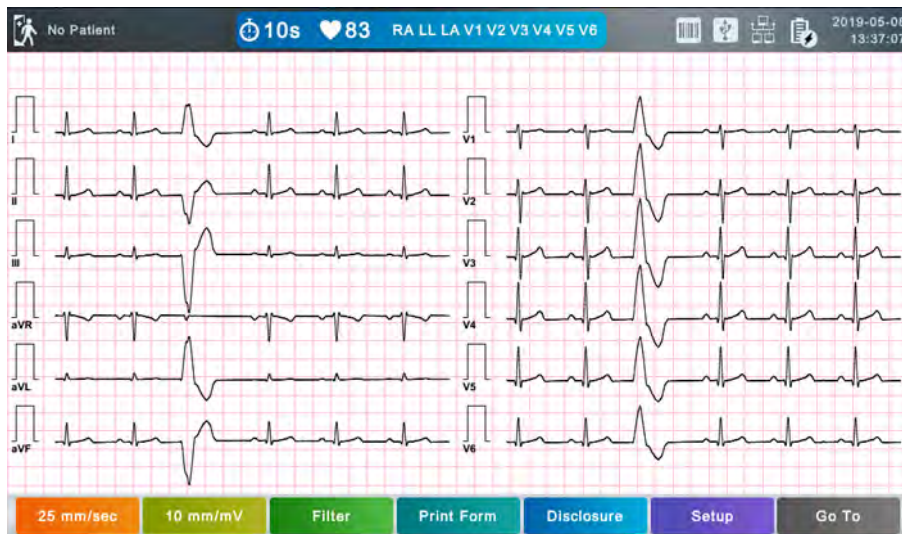

Long-Term ECG

Setting Leads

Use Long-term ECG recording to output 1CH for a longer term such as 1, 3, 5, or 10 minutes, Set the lead to provide the long-term output.

NOTE

Set Lead II because it is the largest in general, however, if its waveform is not large enough, choose another lead with the largest and best waveform.

Preview

Press the [RECORD], [AUTO], or [NETWORK] keys to make diagnosis. After that, you can preview the test results. Set it to On to enable the preview, otherwise set it to Off.

Touch [OK] on the preview to print, save, or send data, or touch [Cancel] to cancel.

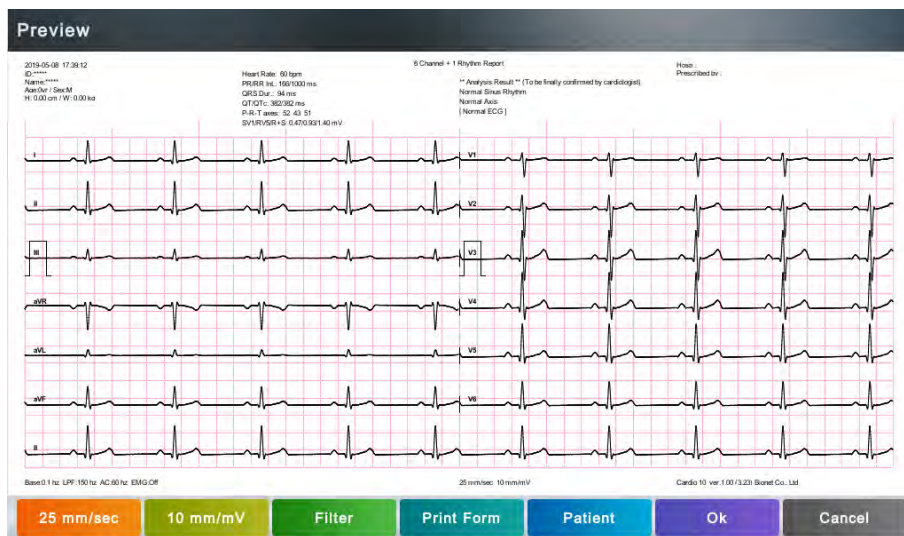

Quick Print

Set the Quick Print options. Since the data pre-saved for a set amount of time (0-10 seconds) is used, it takes less time to acquire data, reducing time to providing data.

NOTE

- With the Quick Print option set, touch the Diagnosis button when the signal stabilizes. Since the data pre-saved for a set amount of time is used, diagnosis and printing may be affected unless the saved data is stabilized.
- Quick Print option is available only for 10-second recording. It cannot be used for long-term (1 minute, 3 minutes, 5 minutes, 10 minutes, 20 minutes, or 30 minutes) recordings.
- If you want to be provided with the arrhythmia section, Bionet recommends using the Disclosure function.

One-touch Button (Auto Key Panel)

On the ECG Main screen, simply touch the screen to execute the function of AUTO key.

Set it to On to show AUTO button.

Touch [AUTO] on the screen to perform AUTO key function.

To change the location of the button, hold it down, move it to the desired location, and release it.

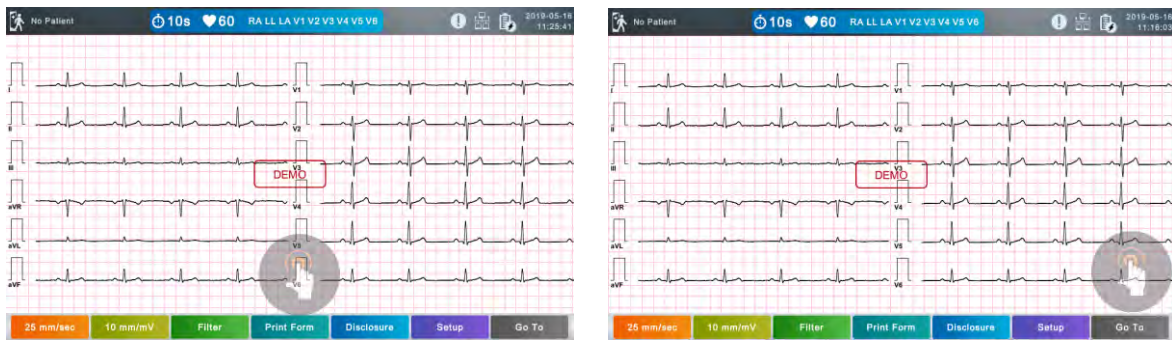

Setting Print Form Group

Refer to the Print Form section described earlier in the manual.

Analysis Setup

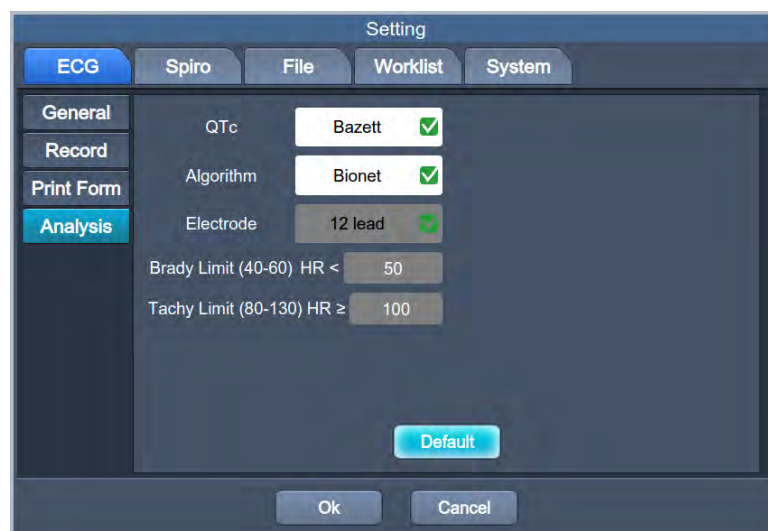

Correct QT Interval (QTc)

QTc estimates the QT interval at a standard heart rate of 60 bpm.

4 official formulas: Bazett, Hodges, Fridericia, and Framingham

Algorithm

Choose an algorithm (Bionet or Glasgow) to analyze the 10-second data.

Electrodes

When using the Glasgow algorithm, choose between standard 12-lead and pediatric V4R.

Brady / Tachy Limit

Set diagnostic criteria when using the Glasgow algorithm. This setting is necessary for automatic

diagnosis on the ECG main screen.

Setting the System

Configure system settings.

Set each group: General, Hospital, Server, Printer, and Service

Setting System-General



Language

Select the language and touch [OK].



NOTE

Even if the set language is not English, some terms, such as diagnosis names, may be shown in English.

Start Option

Set the initial screen that appears when the equipment is turned on. Select the most frequently used function among Main, ECG, Spiro, File, and Worklist.

Date Format

Set the date format.

The set format is applied both on the screen output and printout.

Height Unit

Set the unit to enter the patient's height. Choose between *cm* and *inches*.

Weight Unit

Set the unit to enter the patient's weight. Choose between *kg* and *lbs*.

Volume

On/OFF the Volume.

Screen Brightness

Set the brightness of the LCD screen.

Setting Touchpad (Calibration)

Set the coordinates of the touchpad. When you touch [Calibration] in the Touch menu, a black screen appears in which you set calibration of the touchpad. Enter as directed on the screen to reset the touchpad's coordinates. The touchpad may not work properly if you fail to enter the exact coordinates.

NOTE
When you touch [Calibration] in the touch menu, all screens disappear and you are ready to set calibration.
No key will not work until you complete the calibration.

Set Default Race (Default Race)

Select a race entered by default.

Setting a Hospital

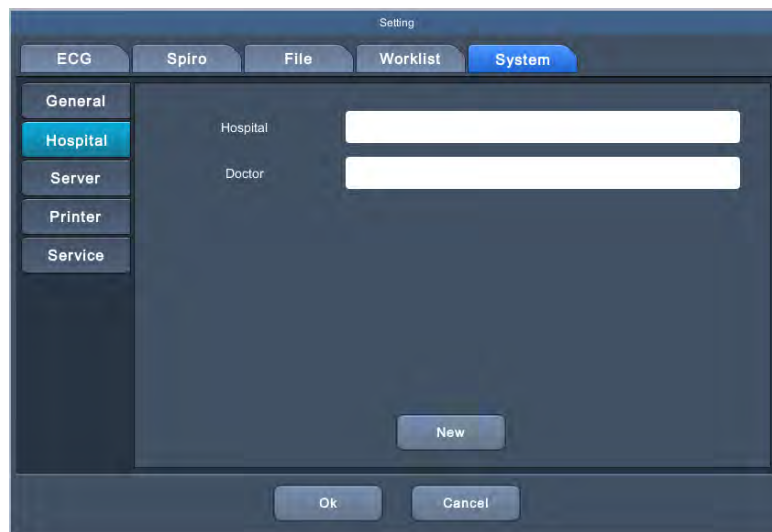

Hospital Information

Enter the name of the hospital.

Doctor Information

Enter the name of the doctor.

Setting a Server



Connecting to a Server (Connect to)

Select a server to which the equipment connects among EMR, PACS, GET and WEB servers.
Select a server you want to connect to and touch [Edit]. The Server Setting screen is displayed.

Setting EMR Server (EMR Server Edit)

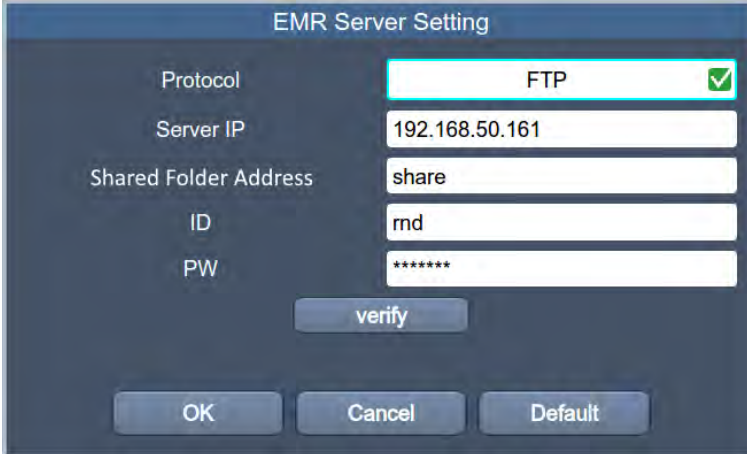

Protocol	FTP <input checked="" type="checkbox"/>
Server IP	192.168.50.161
Shared Folder Address	share
ID	rmd
PW	*****

verify

OK Cancel Default

Protocol

Select a protocol to share the files among FTP, SMB v1, and SMB v2.

Server IP

Enter the IP of the file-sharing server.

Shared Folder Address

Enter the path of the file-sharing folder.

ID

Enter the ID to use to share files.

Password

Enter the password to use for file sharing.

Verify

Touch [Verify] to check if the connection to the file-sharing server is successful.

Setting PACS

Equipment Information (Device)

AE Title and Port

Enter AE Title and Port for the Cardio Q50 / Cardio Q70.

Modality

Enter the Modality of ECG and Spiro.

Spiro Exam Code

Enter the Exam Code for FVC, FEV1/FEV6, SVC, and MVV exams of Spiro.

Character Set

Select a language-specific character set.

When sending a file to the PACS server, you must select an adequate character set to display characters appropriately for each language.

Setting a Worklist Server

IP, Port and AE Title

Enter IP, AE Title and Port for the Worklist server.

Verifying Server Connection (Verify)

Touch [Verify] to check if the connection to the Worklist server is successful.

Date Range

Set the date range to import a worklist from the Worklist server.

Type	Description
Today (today-today)	Today's worklist is loaded. Set both start and end dates to today.
Today (today-blank)	Today's worklist is loaded Set only start date to today.
Yesterday-Tomorrow	A worklist from yesterday to tomorrow is loaded
One Week	A worklist from today to a week later is loaded.
A Week ago	A worklist from a week before to today is loaded.

Auto Update Worklist

If you check Auto Update Worklist, the latest worklist is automatically shown whenever the Worklist screen pops up.

Setting a Storage Server (Store)**IP, Port and AE Title**

Enter IP, AE Title and Port for the storage server.

Verify

Touch [Verify] to check if the connection to the storage server is successful.

Retry Count

Select the retry attempt counts to transmit data when there occurs a transmission error in data communication.

Retry Interval

Select the interval of retry attempts to transmit data when there occurs a transmission error in data communication.

NOTE

To connect to the PACS server, you must enter the Device IP manually. If the IP is set to DHCP, the device IP may change every time the device is turned on. If the changed IP is different from the device IP registered in the PACS server, server connection may not be made.

Dicom TLS

You can connect to Dicom servers with TLS enabled.

Simultaneous Transmission to EMR (Use With EMR)

Decide whether to transmit the data being sent to the PACS to the configured EMR server simultaneously.

Setting GDT

When you select GDT, set additional information in Setting menu.

A screen appears to set Work type, GDT Directory, Component name, File name, and Image type.

Work Type

Set the GDT operation of the equipment.

- Server: Cardio Q50 / Cardio Q70 receives requests and commands.
- Client: Cardio Q50 / Cardio Q70 sends requests and commands.

Shared Folder

Enter the format of sharing folder information and date to be used by the GDT protocol.

Path

Enter the path of the shared folder where the GDT file will be shared.

ID

ID to access the shared folder

Password

Password to access the shared folder

Date

Date format of the file

Receiver / Sender

Enter the name and abbreviation for each of the EMR and Cardio Q50 to be used for the GDT protocol.

Name

Each name of EMR and Cardio Q50

Short Name

Date format of the file.

It is a 3-letter abbreviation for each of the EMR and Cardio Q50 to be used for the GDT protocol.

File Name

Select the name type of the file to be shared by the GDT protocol.

Type

Select the file type to use for GDT transfer.

- <token of receiver> <token of sender>.<incrementing number>
- <token of receiver> <token of sender>.GDT
- <token of receiver> <token of sender>_<incrementing number>.GDT

Image

Select the image format for the data file to be shared by the GDT protocol.

Touch the input field of each item and enter values using the keypad window.

If you finish entering the inputs correctly, a connection success message is displayed at the top of the screen.

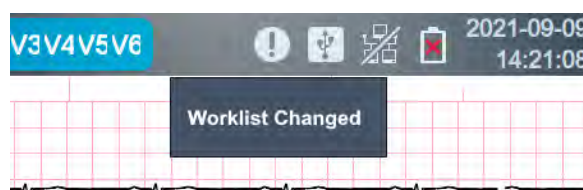

Setting Web (WEB Setting)

When you select Web transmission, set additional information in Setting menu.
A screen appears to set URL, Path, ID, PW, and DNS.



The screenshot shows a dark-themed dialog box with five input fields on the left, each with a corresponding label: URL, Path, ID, Password, and DNS. To the right of these fields is a 'Verify' button. At the bottom of the dialog are three buttons: 'OK', 'Cancel', and 'Default'.

URL

The web address to connect to

Path

The path within the server to transmit the files to

ID

The user ID to use on the web to access

Password

The user password to use on the web to access

DNS

The IP of the server that supports the domain name system

Touch the input field of each item and enter values using the keypad window.

Touch [Verify] to check the connection to the web server.

If the connection is successful, Verify: Success appears; otherwise, Verify: Failed appears.



Setting System Printer

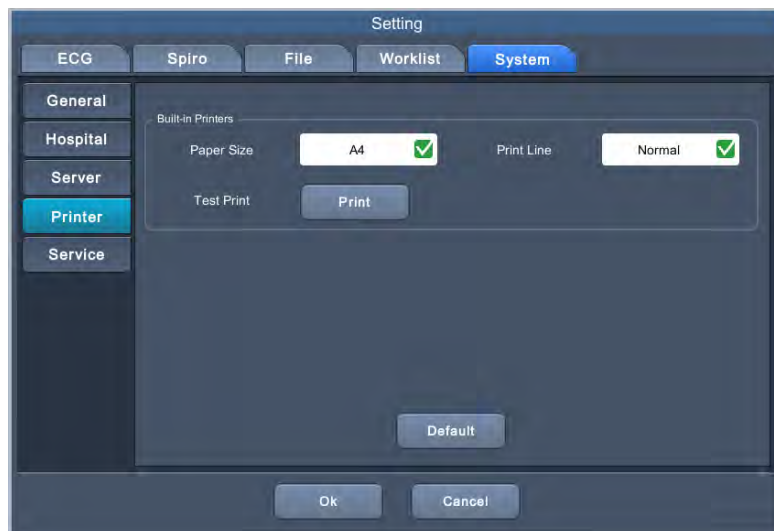

Paper Size

Set the size of the paper.

- A4: A4 size paper
- Letter: The letter size paper

Print Line

Set the boldness of printout.

There are three options: thin, normal and thick.

Test Print

As a print quality test, two test patterns including grid and triangular waveform are printed.

Setting System Service

You can reset settings, delete data, and modify user accounts.

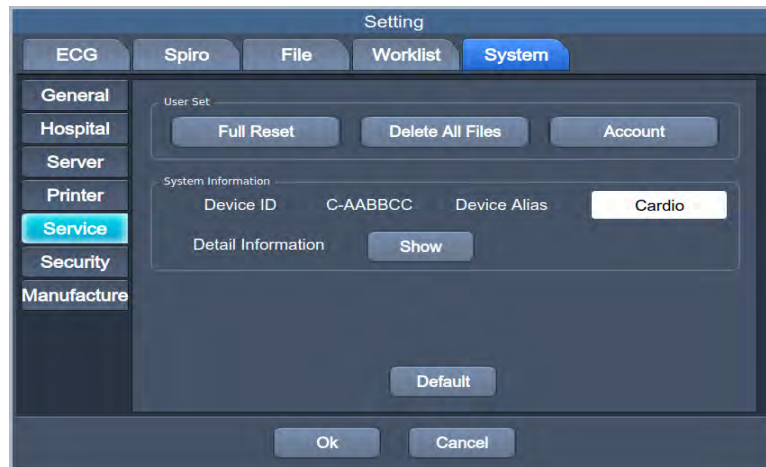

Full Reset

All settings are initialized to the factory mode.

To execute the initialization, enter a password.

NOTE

User password is not initialized at full reset.

Deleting All Files (Delete All Files)

You can delete all data from File and Worklist.

To delete data, enter the password.

Managing Account (Account)

You are moved to the User Information Management for Equipment Use.

See **Chapter 7 User Information Management**.

NOTE

- Contact the Bionet service center when you forget your password.

NOTE

Rules for Creating Passwords

- 10 or more characters: a combination of two of uppercase letters, lowercase letters, numbers, and special characters.
- 8 or more characters: 3 combinations of uppercase letters, lowercase letters, numbers,

and special characters.

System Information

Device ID

Enter a unique ID for the equipment.

Device Alias

Enter an alias for the equipment.

More Information (More Information)

Touch for more information for the equipment.

Setting Security

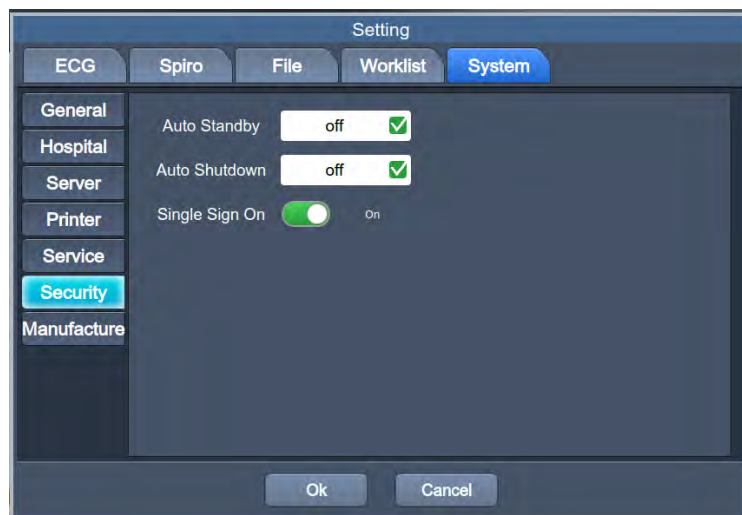

Auto Standby

Set On/Off to activate the standby mode for a security purpose when the equipment is not used for the timeout period.

After the timeout period, the program locks; you should log in again to activate the program.

Set the timeout period to off, 10min, or 30min. When switched to standby mode, you are automatically logged out for security and the screen is dimmed to reduce power consumption.

Auto Shutdown

Set On/Off to shut down the equipment when not used for the timeout period.

Set the timeout period to off, 10min, or 30min. If not used for a set period, the equipment will

automatically shut down.

Single Sign On

Because single sign-on can compromise security, Bionet recommends this setting only for the devices used single or a limited user.

Activate it to enable system authentication of user ID and password.

If it is set, no login is required at the start of the program because user authentication is carried out by the equipment.

Also, if the application timeout is set, you do not need a password to reactivate the application.

Settings are only available with an administrator account.

Setting Manufacture

With the Manufacture function, you can change things related to equipment upgrades and options. If you need any changes, contact the Bionet Service Center.

Part 2 Using Spirometer



Chapter 3. How to Install

1) Connecting Spirometer Handle

Connect the connection terminal of the spiro handle to the USB port on the back of the main unit.

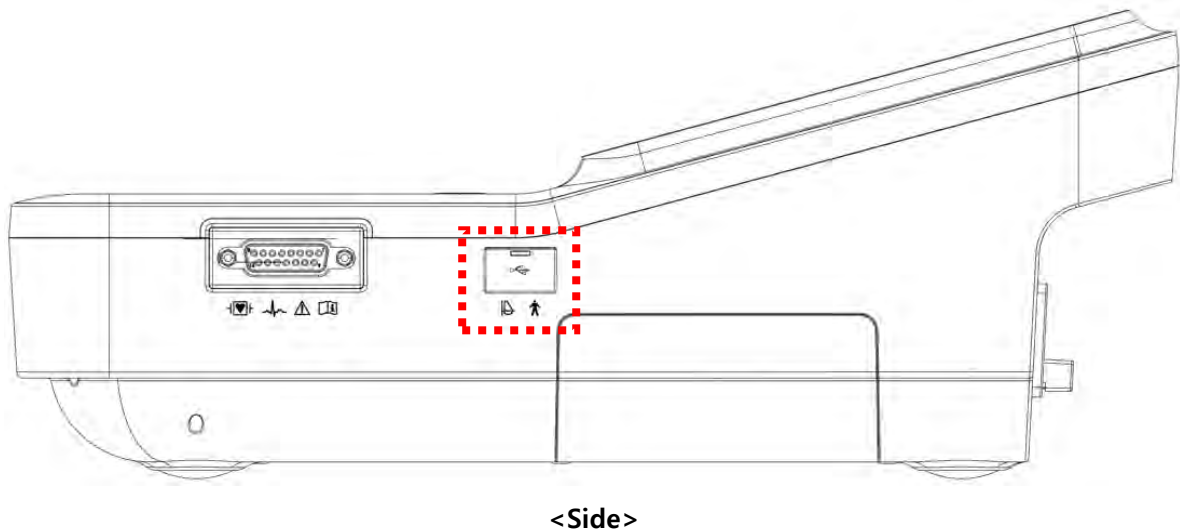

- (1) Connect the spiro handle with the equipment powered off.
- (2) Turn on the power switch of the equipment.

Checking the Operation of the Spiro Handle

If the handle-shaped icon is displayed in the top right menu bar of the equipment, the connection is successful.

2) Installing a Mouthpiece

To start the test, anchor the disposable mouthpiece to the top of the spiro handle. First, press the Front Cover Lock Switch on left top corner of spirometer handle to open the semicircular Front Cover, and accurately fit the mouthpiece on the inserting slot made on the open side. Press the Front Cover with a little force to close it. The tube of the mouthpiece should be long on the front side and short on the rear side of the spiro handle if the mouthpiece is correctly anchored.



(1) Press the Front Cover Lock Switch on the top left corner of spirometer handle and open the Front Cover in semi-circle shape.



(2) Put the mouthpiece on the inserting lot made on the open side.



(3) Press the Front Cover with a little force to close it.

CAUTION

- A mouthpiece is for single use only.
- Do not close the cover while pressing the lock switch.

Chapter 4. How to Use

1) Getting Started

Turn on the equipment and touch [Spiro] to enter the spirometer main screen.



<Spirometer main screen>

Touch one of the items on the screen above.



Touch the buttons on the screen to make them function.

2) Entering Patient Information

Enter the patient's personal information before starting the lung function test.

Fields marked with  are required inputs. Age, Gender, Height, Weight, and Race are required inputs for lung function diagnosis.

Patient ID

Enter a unique number used in the hospital to classify patient medical data. Touch the input field of ID to display the keypad window consisting of alphabets and numbers. Use the keypad window to enter patient ID. Touch the  (Caps Lock) key at the bottom left to switch from lowercase to uppercase or vice versa. Touch  (Enter) to save the patient ID. The keypad window disappears.

NOTE

- Do not use - `-=W[];',./ ~!@#\$\$%^&*()_+{|}:W" <>? characters for ID.
- Use only plain alphabets and numbers for ID. If you enter an ID in Latin extended characters or Russian, an error may occur when you transfer files with the IDs to a PC or USB memory.

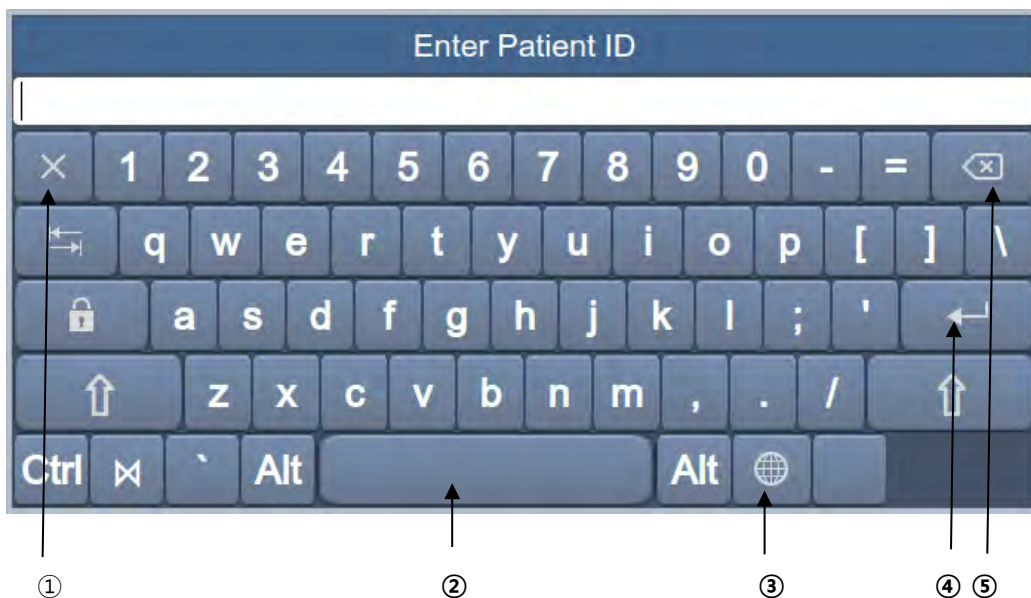

- ① Close
- ② Space Bar
- ③ Multilingual key
- ④ Enter key
- ⑤ Backspace key

Patient Name

Enter the patient name in the same way as entering the ID.

Date of Birth (Birthday)

Touch the input field of Birthday to display a number pad as below. Enter the patient's date of birth. Patient's age is automatically calculated and entered.

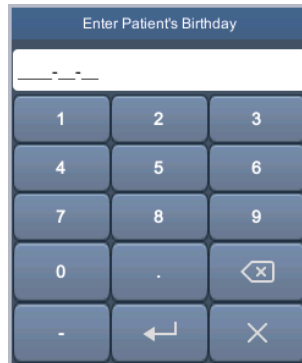
**Age**

Enter the patient's age directly.

Gender

Touch the input field of Gender to select Male or Female.

Height

Enter the patient height in the same way as entering the age.

If the Height Unit is set to inches in System General Setup, enter the height in *ft* and *inches*.

Weight

Enter the patient weight in the same way as entering the age.

Race

Enter the race of the patient. There are 3 registered races: Asian, White, and Black.

When selecting GLI-2012, there are five registered items: White, Black, North East Asian, South East Asian, and Other.

Touch the input field of Race to select the race type.

Smoking History

Mark whether the patient is smoking.

Urgent

Mark whether the patient needs urgent care.

Other Information

Enter Department, Room No., Study Description, Accession No., and Referring Physician in the same way as entering ID.

Touch [OK] to save the settings or [Cancel] to cancel the settings. Touch [New] to initialize all the patient information you have entered.

3) Forced Vital Capacity (FVC) Test

FVC Test is to examine the forced lung capacity.

The FVC Test is divided into: A Base test before taking drugs and a Post test after taking drugs.

FVC Test (Base Test)

Touch [FVC] on the Spirometer ~~initial~~ main screen.

When the test is prepared, the FVC test screen appears.

If the spiro handle is not connected, or if there is an issue with the handle, a message appears as shown below. The same message appears for FEV1/FEV6, SVC and MVV tests. Touch [Close] and check the handle before restart the test.

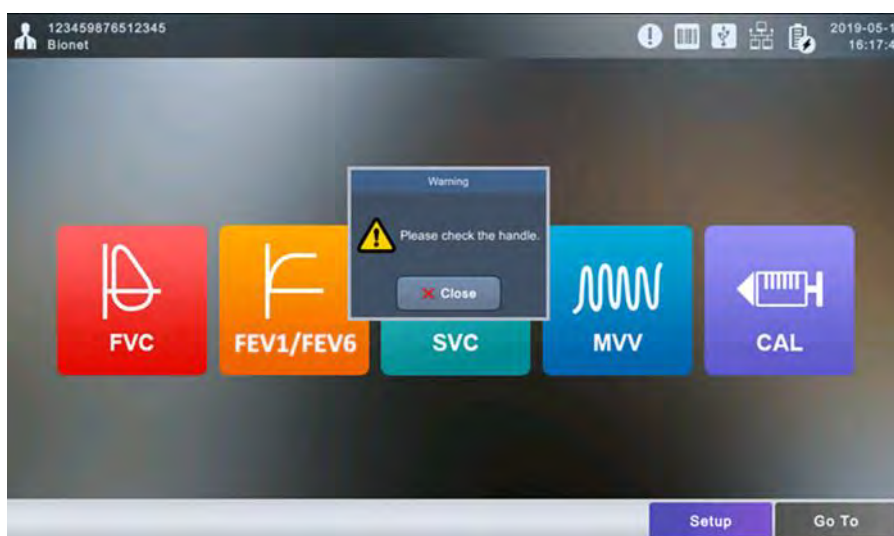

The following screen appears if the spiro handle is connected well. Now you are ready to start the FVC test.

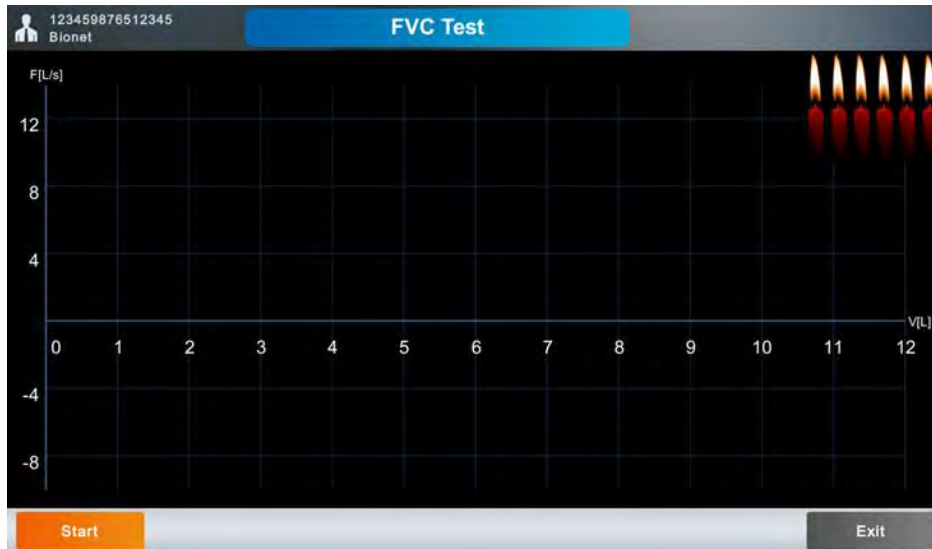

Have the patient hold the spiro handle and place it in front of his or her mouth, and touch [Start]. When the equipment sounds a beep indicating the start of the test, have the patient bite the mouthpiece and start the test.

Follow the procedure below to achieve accurate test result.

< How to Breathe during FVC Test >

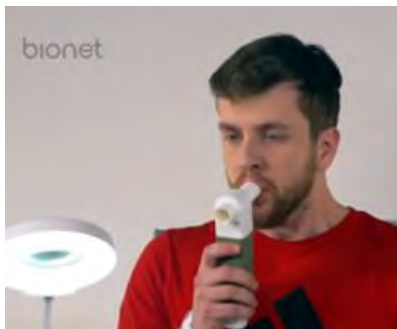

1) Breathe twice or more as usual.

Prepare for the measurement while breathing as usual. This is recommended to achieve accurate test results.



2) Inhale as much as possible. (TLC level)

Breathe in as much as you can regardless of the speed. (Instruct the patient to inhale as much as he or she can.)

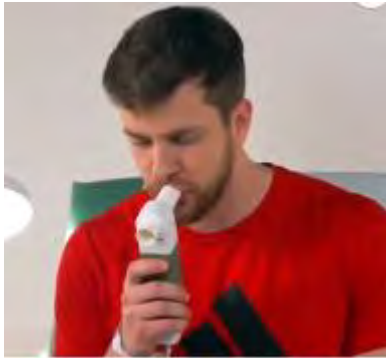
**3) Exhale as fast and much as possible. (Forced expiration)**

Exhale as fast as possible and also as much as possible. Try to blow off all 6 candles in the candlelight animation. 1 candle means 1 second.

**4) Inhale fast and much as possible. (Forced inspiration)**

Now that you are running out of breath, you are naturally panting for breath, but you should try your best to inhale as much as possible, not to inhale in order to overcome your shortness of breath.

5) Touch [Stop] to end the test.**NOTE**

- In principle, the patient should be in standing position. The test can be done in a sitting position as well, but the more effortful lung capacity are acquired in standing position. Pregnant women, obese people and pediatric can sit down to take the test.
- Raise your chin upwards by about 15 degrees and keep it all the way: avoid bending your neck or chin. Do not bend or twist your back, and keep the original posture until you're done with the test.

Result Screen

Touch [Stop] after the test to open the result screen.



- ① Flow Volume Graph
- ② Volume Time Graph
- ③ Parameters
- ④ Best Result

Selecting Best Result

After the test, the BEST result number is indicated, which is chosen by the measurement data.

The best result is the maximum value of FVC+FEV1.

To change the auto-selected best result, touch a different result number.

New

Start a new test. Touch [New] to start a new test.

If you touch [New], a message asking whether to accept the previous test result appears. Here, [Yes] increases the number of tests and [No] ignores the previous result.

In a new exam screen, touch [Start].



Print

Print out the test result.

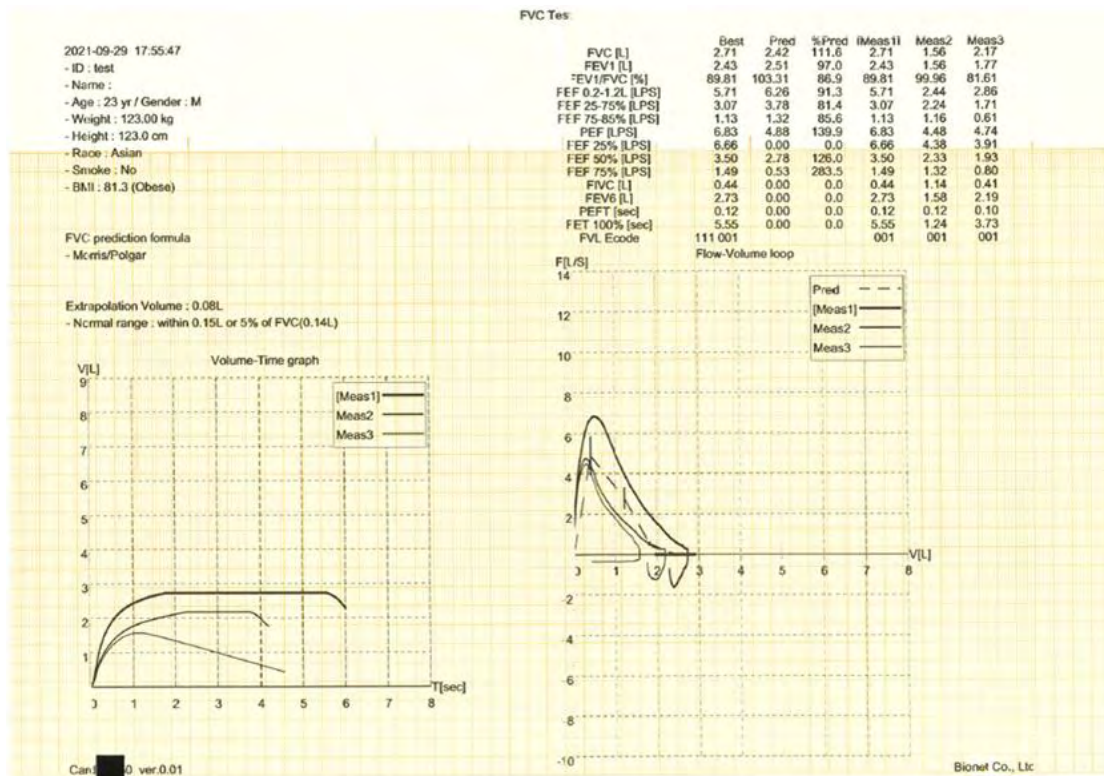

NOTE

Do not attempt to attach or detach a USB device while the printer is working as it may cause the printer module to rattle.

Network

Send the test result to the server.

Auto

Auto function saves, transmits, and prints test results at once. It functions according to the AUTO key settings set in System General Setup.

Exit

End the test and return to the Spiro main screen.

Set save option in Setup → Spiro → General → Save Option On Exit.

FVC Post Test (Test after taking drugs)

The FVC Post test is a post-medication test. You can compare the results of the 2 tests before and after the patient takes drugs.

Follow the procedure below.

- (1) Conduct a test according to the FVC base test procedure and save the data.
- (2) In the File menu, you can see the patient ID whose study type is marked as FVC.

ID	Name	Sex	Age	DateTime	Study
123459876512345	Bionet	M	45yr	2019-05-13 17:01:07	FVC
123456789012345	bionet	M	32yr	2019-05-10 18:53:49	ECG
123456789012345	bionet	M	32yr	2019-05-10 18:52:09	ECG
123456789012345	bionet	M	32yr	2019-05-10 13:49:15	ECG
w24567806432	ljio	F	45yr	2019-04-30 18:50:35	FVC
w24567806432	ljio	F	45yr	2019-04-30 18:42:25	FVC
w24567806432	ljio	F	45yr	2019-04-30 18:16:15	FVC
w24567806432	ljio	F	45yr	2019-04-30 17:35:26	FVC
w24567806432	ljio	F	45yr	2019-04-30 16:05:59	FVC
w24567806432	ljio	F	45yr	2019-04-30 15:46:15	FVC

Test result before taking drugs

- (3) Once the patient has taken his or her drugs and the test is ready, select his or her FVC data from the file list and select Spiro by touching [Go To].
- (4) When you select Spiro, the FVC test screen appears.

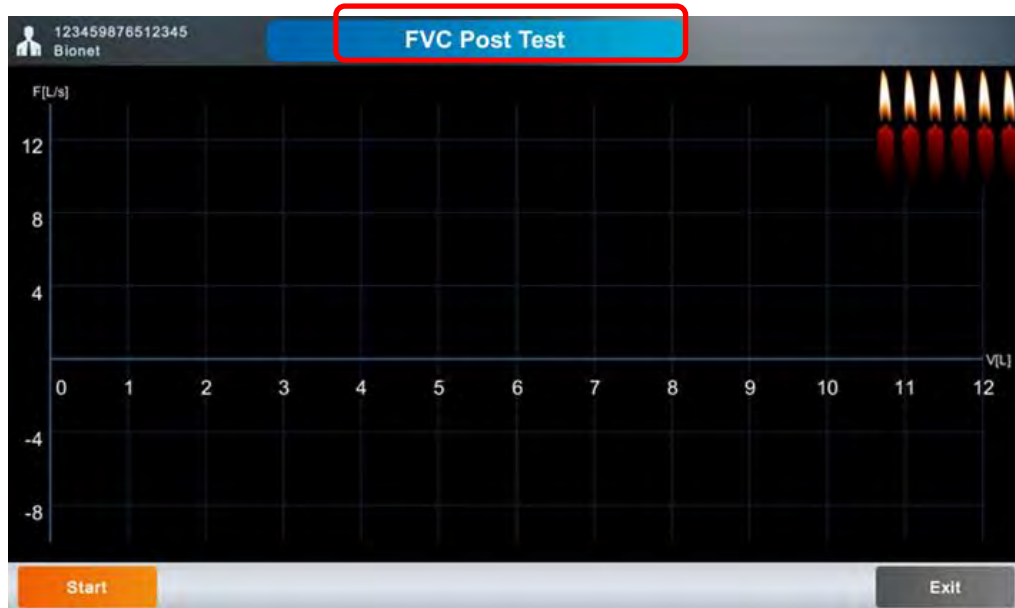

(5) Test in the same way as the FVC base test.

(6) Print the test results and compare parameters and graphs of Base test (before taking drugs) and Post test (after taking drugs).

(7) Touch [Exit] to end the test.

In the File list, you can see the data where the study type of the patient ID is marked as FVC+. FVC+ file is saved with all the measuring data before and after taking drugs.

ID	Name	Sex	Age	DateTime	Study
123459876512345	Bionet	M	45yr	2019-05-13 17:01:07	FVC+
123456789012345	bionet	M	32yr	2019-05-10 18:53:49	ECG
123456789012345	bionet	M	32yr	2019-05-10 18:52:09	ECG
123456789012345	bionet	M	32yr	2019-05-10 13:49:15	ECG
w24567806432	ljio	F	45yr	2019-04-30 18:50:35	FVC

Test result before taking drugs

NOTE

- To conduct both base test and post test, set the FVC Post Test of Spiro General Setup to On.

- FVC Post Test Printout

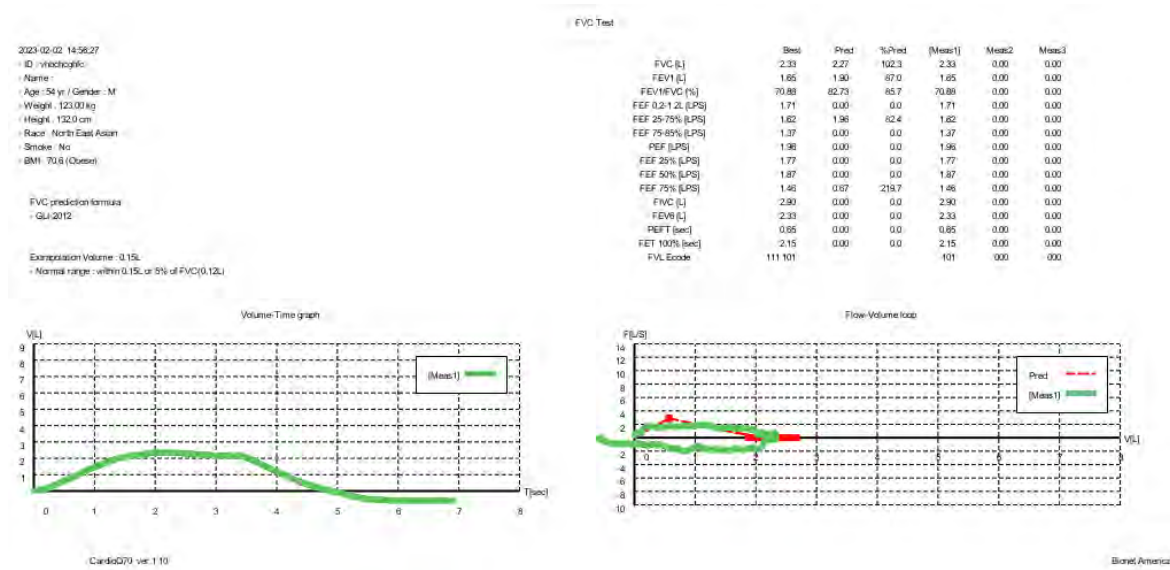

4) FEV1/FEV6 Test

To test FEV1/FEV6, touch [FEV1/FEV6] on the Spirometer initial screen.

When you select FEV1/FEV6, the FEV1/FEV6 test screen appears.

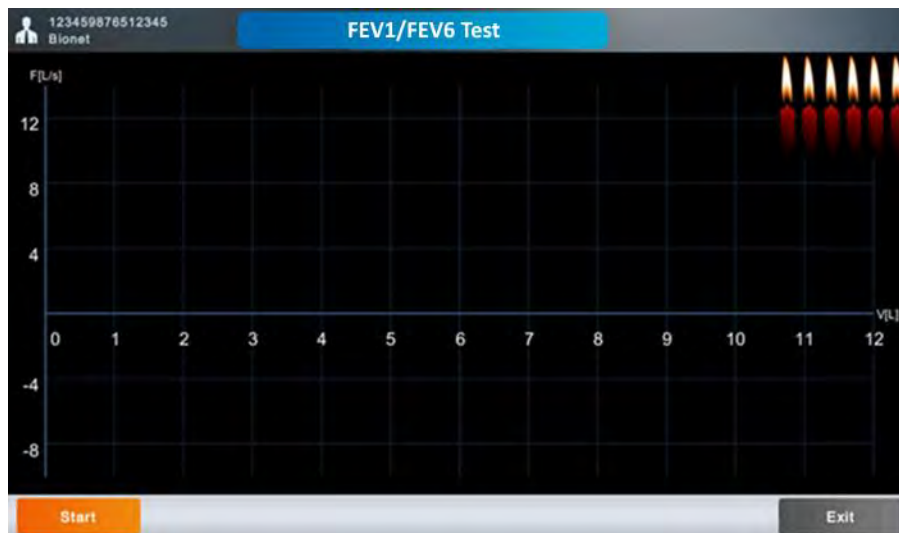

Have the patient hold the spiro handle and place it in front of his or her mouth, and touch [Start].

When the equipment sounds a beep, have the patient bite the mouthpiece, and start the test.

Follow the procedure below to achieve accurate test result.

< How to Breathe during FEV1/FEV6 Test >**1) Inhale as much as possible.**

Inhale as much as possible regardless of the speed. (Instruct the patient to inhale as much as he or she can.)

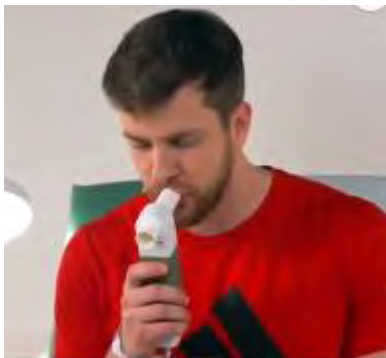
**2) Exhale slowly as much as possible.**

Exhale as much as possible for more than 6 seconds until you have no more breath left.

**3) Inhale as fast and much as possible.**

Now that you are running out of breath, you are naturally panting for breath, but you should try your best to inhale as much as possible, not to inhale in order to overcome your shortness of breath.

4) Touch [Stop] to end the test.

Results Screen

Touch [Stop] after the test to open the result screen.

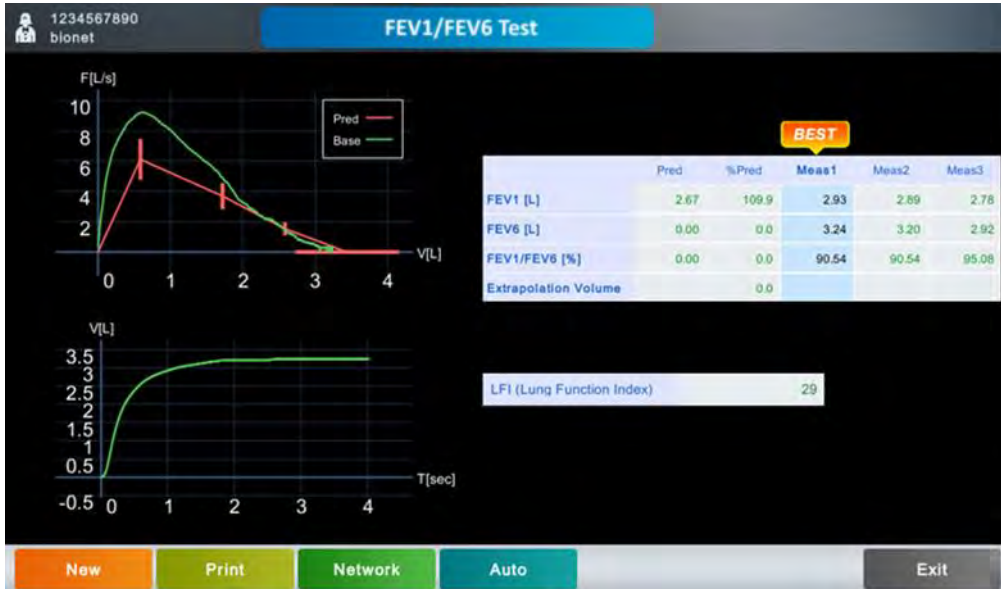

The best result is the maximum value of FEV1+FEV6.

Use the Best, New, Print, Network, Auto, and Exit menus in the same way as in the FVC test.

- FEV1/FEV6 Test Printout

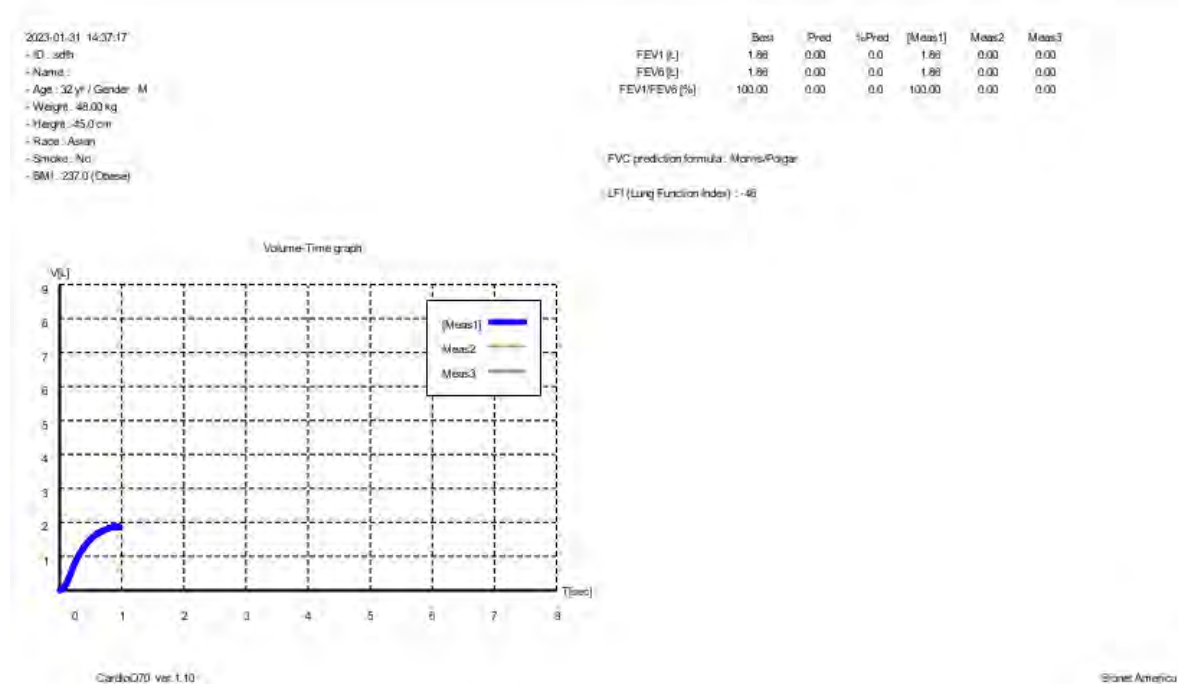

5) Slow Vital Capacity (SVC) Test

Touch [SVC] in the Spiro main screen to start SVC testing.

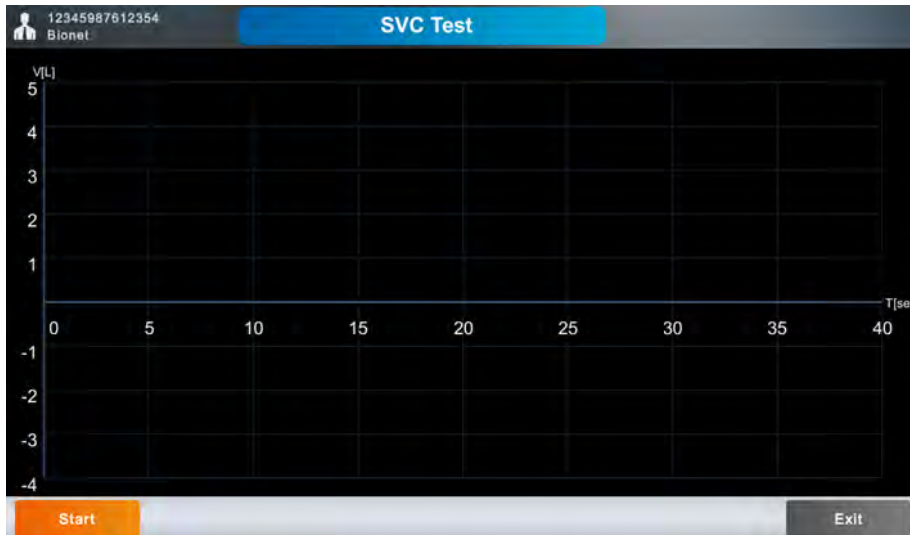

Have the patient hold the spiro handle and place it in front of his or her mouth, and touch [Start]. When the equipment sounds a beep, have the patient bite the mouthpiece and start the test. Follow the procedure below to achieve accurate test result.

< How to Breathe during SVC Test >

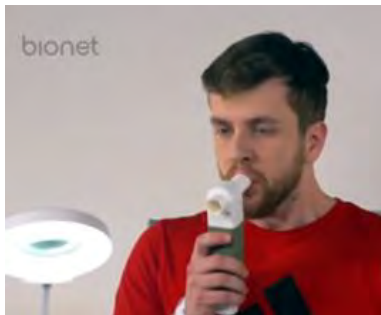

1) Breathe as usual for at least four times

You will hear a click if breathing is detected as usual for more than four times.

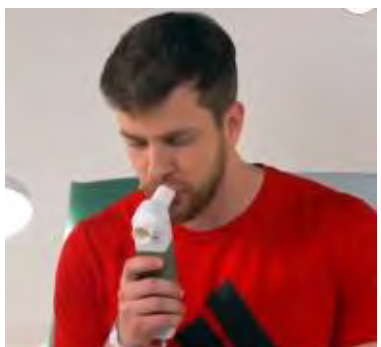

2) Exhale slowly as much as possible (RV level).



3) Inhale slowly as much as possible (TLC level).

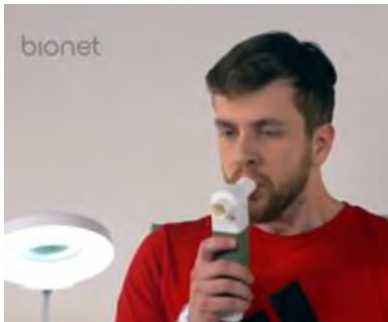

4) Return to normal breathing.

If you breathe in the above order, the breathing speed is shown on the graph (V-T). Breathing as usual is shown smaller and a bigger graph is shown on the screen if you have followed the order from 2) to 3).

A positive velocity (F[L/s]) means exhaling and a negative velocity means inhaling.

Touch [Stop] after the test. A (V-T) graph showing the changes in the lung capacity over time appears.

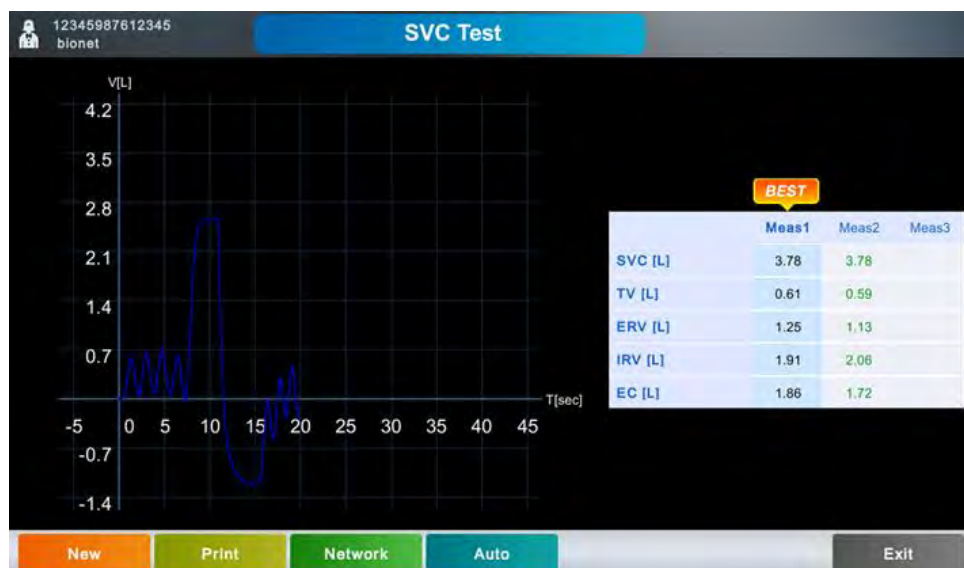

The best result is the maximum value of SVC.

Use the Best, New, Print, Network, Auto, and Exit menus in the same way as in the FVC test.

- SVC Test Printout

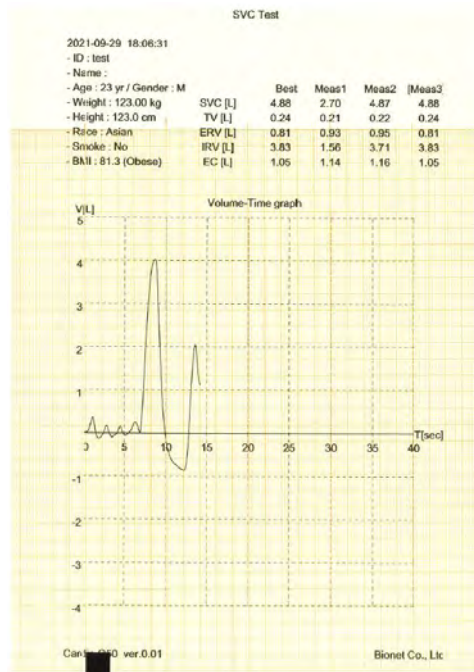

6) Maximum Voluntary Ventilation (MVV) Test

Touch [MVV] in the Spiro main screen to start MVV testing.

Touch [Start] in the screen shown below to start a test.

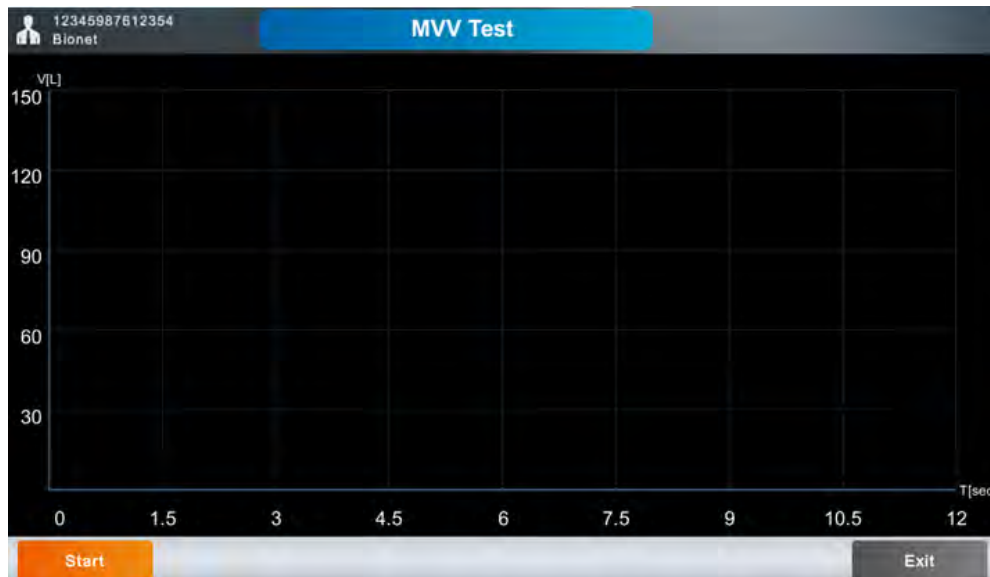

Have the patient hold the spiro handle and place it in front of his or her mouth, and touch [Start]. When the equipment sounds a beep, have the patient bite the mouthpiece and start the test. Follow the procedure below to achieve accurate test result.

< How to Breathe during MVV Test >

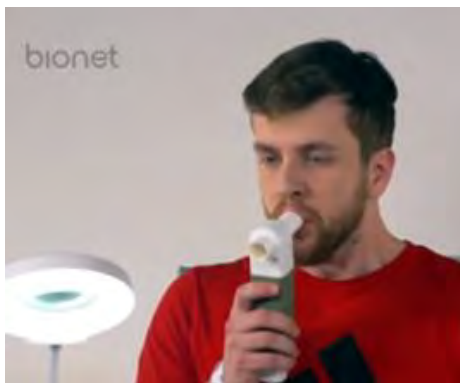

- 1) Start a new test.
- 2) Breathe as fast and much as possible. (MVV)
- 3) When the set time (TMVV) passes, the test ends and the result is displayed on the screen. (TMVV is set to 12 seconds.)
- 4) Return to the normal breathing.

A Volume-Time graph is drawn on the screen if you breathe in the above order. The volume is the amount of the absolute values of the capacity of both inhaled and exhaled breath.

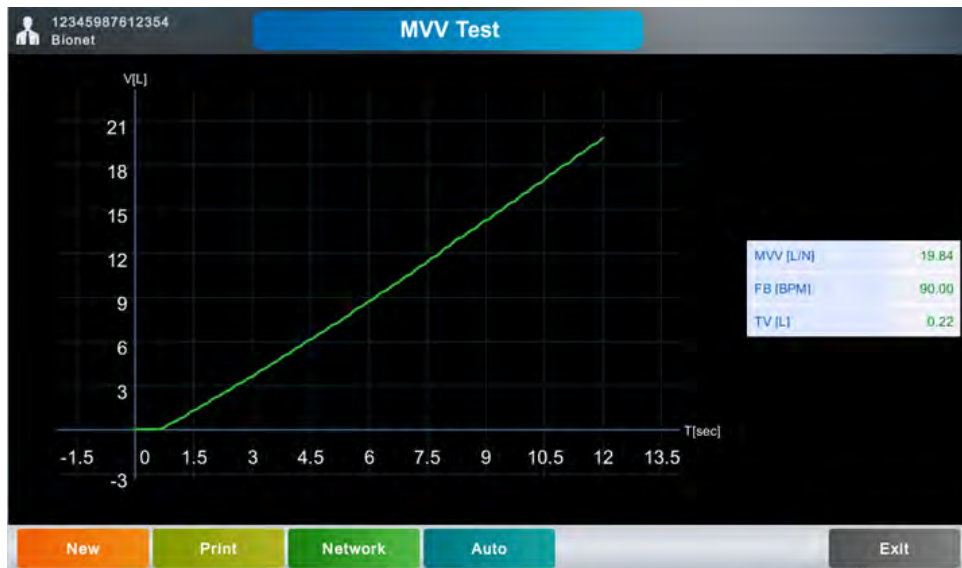

When the set time (TMVV) - 12 seconds - passes, the test ends and the result is displayed on the screen. MVV, respiratory cycle (FB), and total respiratory capacity (TV) are calculated and displayed at the top of the screen. Touch [Stop] to finish during the test. You are moved to the initial MVV test screen.

New, Print, Network, Auto, and Exit menus in the same way as in the FVC test.

- MVV Test Printout

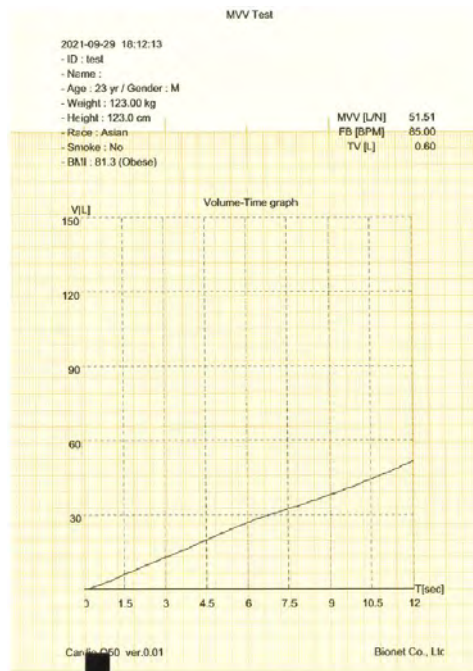

7) Calibration

Touch [CAL] in the Spiro main screen to start Calibration.

On the screen below, touch [Start] to start Calibration.

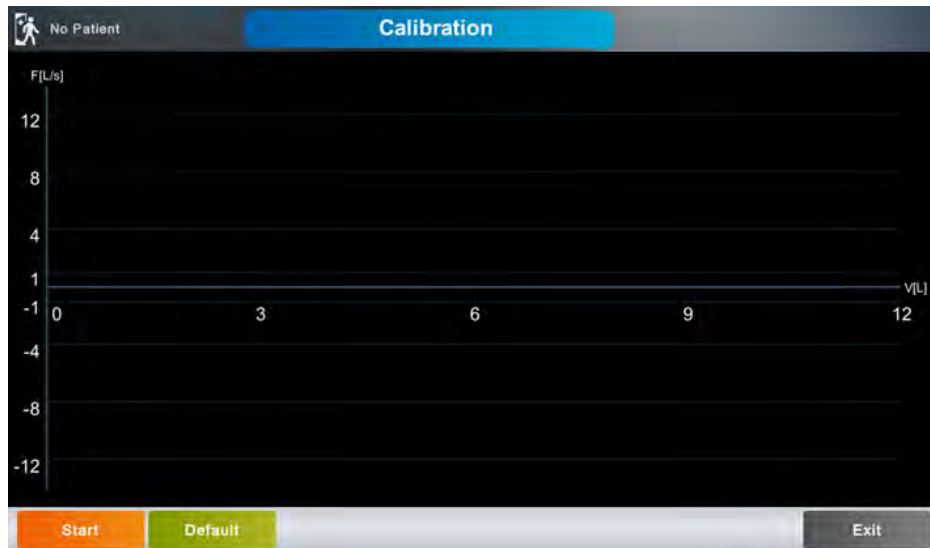

Proceed with the calibration in the following order. Follow the procedure below to achieve accurate test result.

- 1) Connect the spiro handle to the equipment.
- 2) Connect the mouthpiece to the spiro handle into the mouth of the syringe. Fit them tightly to make them air tight.
- 3) Touch [Start] to start calibration. You will hear a click when it is ready for calibration.
- 4) Move the handle of the syringe back and forth 5 times each. Move the handle only when you hear a click.
- 5) Decide whether to apply the calibration results.

Calibration

When you are ready, touch [Start] to start calibration. When you move the handle of the syringe back and forth, the screen shown below appears. Move the handle only when you hear a click to obtain accurate result.

A graph representing Flow and Volume is drawn according to the movement of the syringe. After you move the syringe back and forth 5 times each, volume measuring results and error (%) are

shown on the screen as below. If there is no click every time you move the syringe, touch [Exit] to return to the initial Calibration menu and start again.

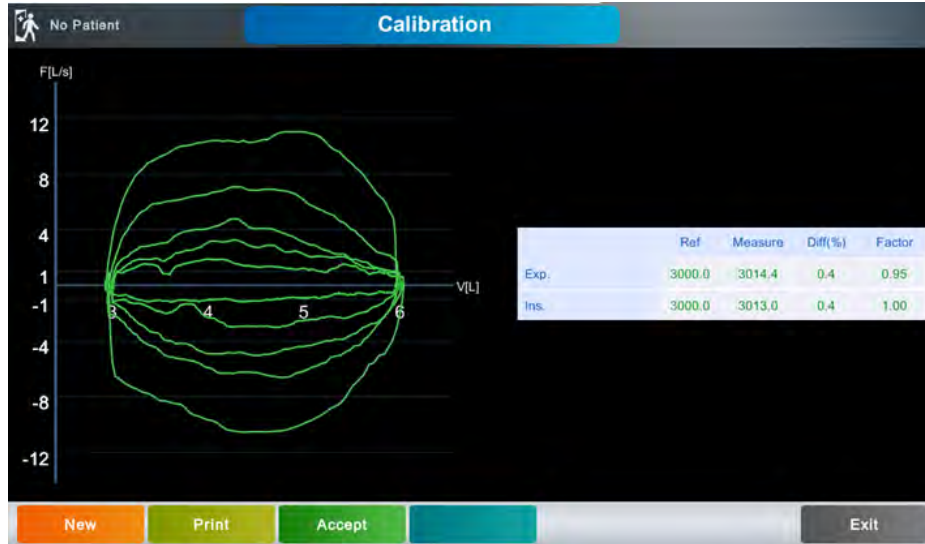

Touch [Print] to print out the Calibration results.

Touch [Accept] to apply the Calibration results to the equipment.

Touch [Exit] to finish Calibration and return to the top menu.

NOTE

- Bionet recommends quarterly calibration of spirometer measuring device. Be sure to perform calibration when changes in temperature and air pressure are significant.
- Repeat the calibration until the calibration result falls within $\pm 3\%$.
- A graph of not less than ± 0.5 litres shall be drawn during syringe calibration. It is recommended to calibrate so that the graph is drawn at least once within the range of ± 4 liters, ± 8 liters, and ± 12 liters.

- Calibration results printout

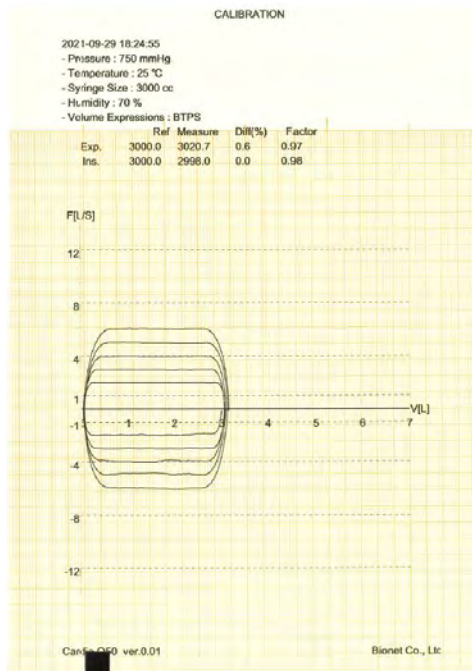

8) Setting Spiro

Touch [Setup] on the lower menu bar of the Spiro main screen to change the settings. You can set Spiro-related settings for each group.

Touch [Default] to enter default values for each input field in the current screen.

Touch [OK] to save the settings or [Cancel] to cancel them.

Spiro General Setup



FVC

Diagnostic Prediction Formula

Select one of Morris/Polgar, Knudson/ITS, ECCS/Quanjer, Korea CJK, and Pereira, GLI-2012 which are prediction formulae that serve as a diagnostic standard for FVC measurement. Set your formula according to the region or race where the equipment is used. The default is Morris/Polgar.

Main Use Area	Formula	Description
North America	Morris/Polgar	Widely used in North America (Default Value)
	Knudson/ITS	Widely used worldwide
Europe and Latin America	ECCS/Quanjer	Widely used in Europe
	Pereira	Widely used in Latin America
Korea	Korea CJK (Choi Jung Geun-Type)	A formula developed to suit the characteristics of Koreans
United States and East Asia	GLI-2012	Multiracial formula for all ages

Test Count

Set the number of tests. In general, set 3 times, but set 8 times for special health checkups.

Post Test

The FVC Test is divided into: A Base test before taking drugs and a Post test after taking drugs. To conduct Post test, set it On. Otherwise, set it Off.

Editing Parameters (Parameter Table)

Set FVC parameters for providing.

Parameter Output Level

Order-shifting Buttons

- ① Move to the top
- ② Move up one level
- ③ Move down one
- ④ Move to the bottom

Type	Description
Screen Display	Basic parameters displayed on the screen after FVC test when Test Count is set to 8 times.
Print Basic	Parameters shown when FVC Print Parameter is set to Basic: They are shown in the screen as well if the Test Count is set to 3 times.
Print All	Parameters shown when FVC Print Parameter is set to All.

FVC Print

Drawing Graphs

Set whether to draw all graphs or only the best graph of FVC test.

When set to All, all tested graphs are drawn, and when set to Best, only the graph selected as Best is drawn.

NOTE
<ul style="list-style-type: none">- Even if the FVC Graph is set to All, only the best graph is drawn after FVC Post test.- Even if the FVC Graph is set to All, only the best graph is drawn when the FVC Test Count is set to 8 times.

Parameters

Set FVC parameters to All or Basic for providing.

When set to All, all 15 parameters in the parameter table are shown, and when set to Basic, 10 parameters are shown.

NOTE
If the FVC Test Count is set to 8 times, 10 parameters set to Basic are shown regardless of the parameter setting.

Extrapolation

You can determine whether to state Extrapolated Volume during FVC testing. Set it to On or Off.

The 1-second effort-based lung capacity is calculated for the 1 second after first blowing. Lung capacity equipment tends to calculate the 1 second from when blowing weakly as a part of effort-based lung capacity if blowing weakly in the beginning due to hesitation followed by hard blowing. However, the effort-based lung capacity shall be calculated for the 1 second after the hard blowing and this difference is called as extrapolated volume.

The valid value for extrapolated volume is 0.15L or within 15% of FVC.

Setting Spiro Test Environment

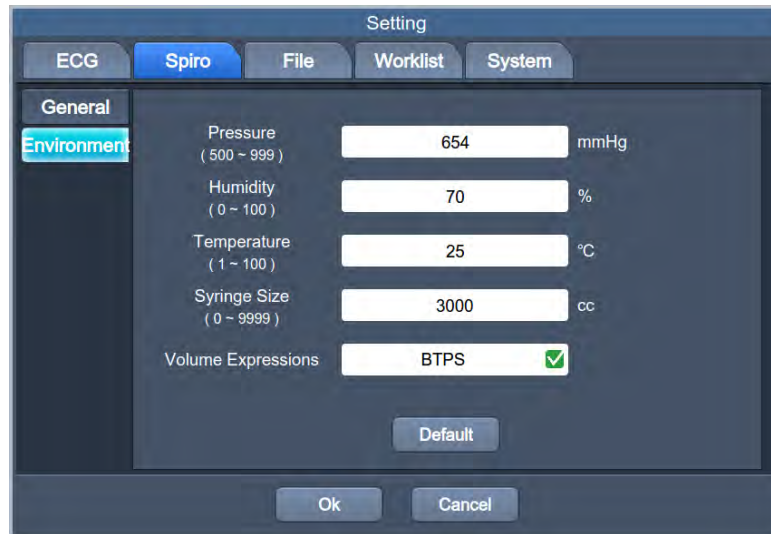

The screenshot shows a 'Setting' dialog box with tabs for ECG, Spiro, File, Worklist, and System. The 'Spiro' tab is active, and the 'Environment' sub-tab is selected. The settings are as follows:

Parameter	Value	Unit
Pressure (500 ~ 999)	654	mmHg
Humidity (0 ~ 100)	70	%
Temperature (1 ~ 100)	25	°C
Syringe Size (0 ~ 9999)	3000	cc
Volume Expressions	BTPS	<input checked="" type="checkbox"/>

Buttons: Default, Ok, Cancel

Touch each input field of Pressure, Humidity, Temp and Syringe to enter values.

Part 3 Data and System Management

Chapter 5. Exam-requested Data Management

1) Screen Description

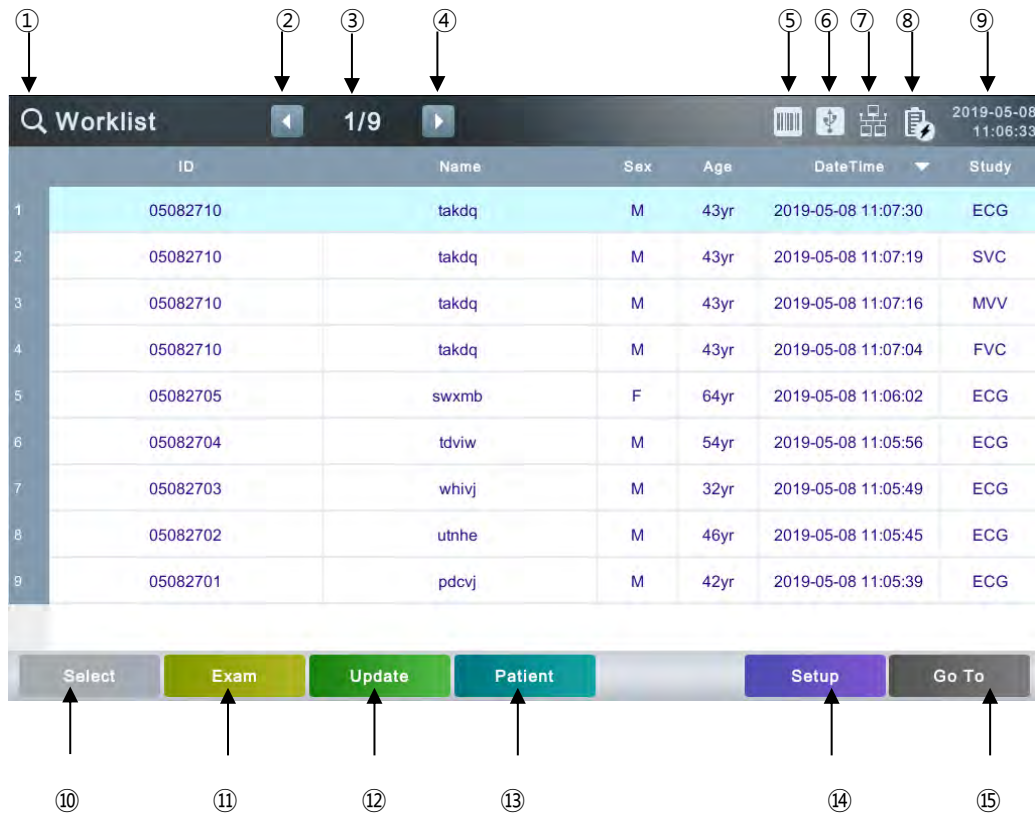

- ① Worklist Search
- ② Go to the previous page.
- ③ Current page/total number of file pages
- ④ Go to the next page.
- ⑤ Connection status of the external device (barcode reader)
- ⑥ Connection status of the external device (USB memory)
- ⑦ Network connection status: Touch this button to set the network.
- ⑧ Battery status or AC power connection status
- ⑨ Current date and time: Touch this button to set the date and time.
- ⑩ Multi-selection button: Enabled only when EMR, GDT, or WEB server is connected.
- ⑪ Go to Exam screen.
- ⑫ Worklist update button: Changed to Delete button when EMR, GDT, or WEB server is connected.
- ⑬ Patient information

- ⑭ Setup Menu
- ⑮ Touch this button to move to other menus such as ECG, Spiro, File, or Worklist.

2) Functions

Search

Touch the magnifying glass button at the top left of the screen to enter a search condition.
Touch Search Item to enter ID, Name, Accession No., Age, and Date.



Select an item and enter the search condition.

When you select ID, Name, and Accession No., a text box where you can enter search text is displayed.

Touch it to enter text using the keypad window.

If you search by age and date, a text box that allows you to enter a start and end number is displayed as shown below.

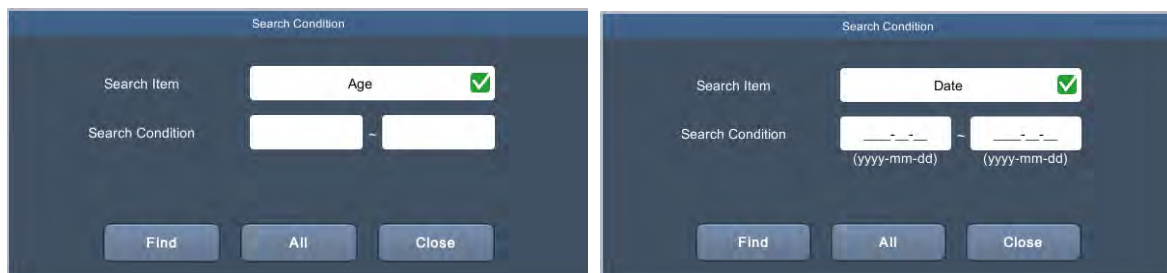

The fields front and back are the start and end range, respectively.

With no start range specified, files are searched from the first to the end range.

With no end range specified, files are searched from the start range to the last.

Conducting an Exam (Exam)

Touch [Exam] to load the ECG exam screen for the current worklist patient.

Loading Exam Screen Using a Barcode Reader

Scan the patient's barcode with a barcode reader on the worklist screen to automatically move

to that patient's exam screen.

When scanning a barcode, select a search item in Setup → Worklist → General → Barcode Search. Search items are ID, Name, and Accession No.

When the patient's information is not found in the list on the screen, if PACS server is connected, patient information is searched in the server and shown in the exam screen.

NOTE
To save test data, set ECG Store to Yes in Auto Key setup and conduct the test by touching [AUTO] on the exam screen.

Deleting Exam Data (Delete)

You can delete the selected worklist, either one or multiple files at a time.

The Delete menu is available only when EMR, GDT, or WEB server is connected.

NOTE
Care has to be taken as initialized files cannot be restored.

Update Exam Information

Load recent exam information from PACS server.

The Update menu is shown only when EMR, GDT, or WEB server is connected.

Viewing Patient information (Patient)

View or modify the patient information in the selected lists.

3) System Settings

Touch [Setup] on the exam-requested data screen to open the Worklist General Setup screen as shown below.

Worklist General Setup

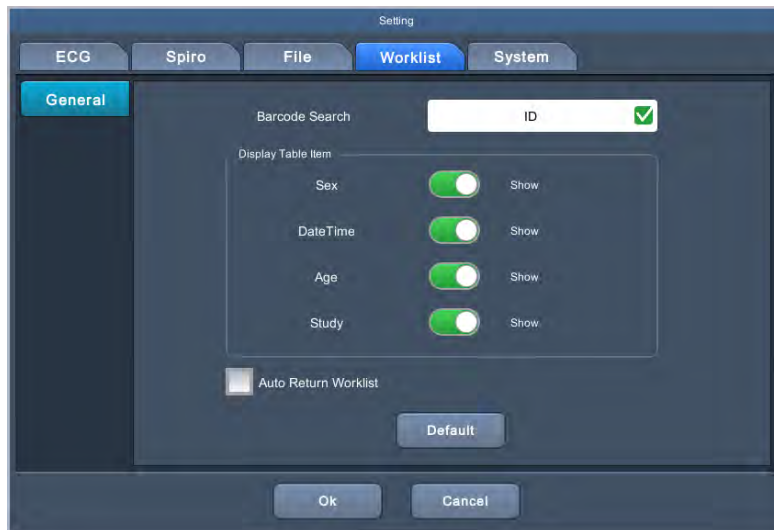

Barcode Search

Scan the patient's barcode with a barcode reader on the worklist screen to automatically move to that patient's exam screen. Set the search items such as among ID, Name, and Accession No.

Display Table item

Set the items to be shown on the worklist main screen.

Changing display items triggers auto-adjustment of spacing between them.

Auto Return Worklist

Set whether to automatically return to the worklist screen from the exam screen (ECG or Spiro). Check the box to enable auto-return.

Chapter 6. Data Management

1) Screen Description

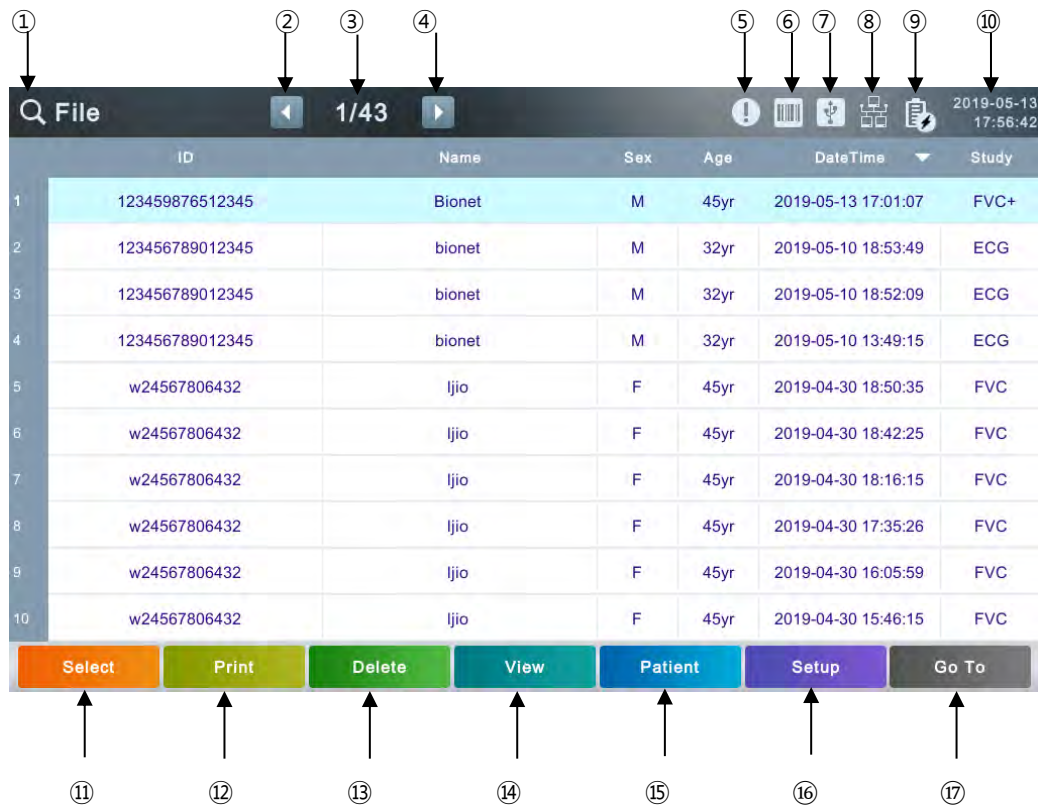

- ① File list Search
- ② Go to the previous page.
- ③ Current page/total number of file pages
- ④ Go to the next page.
- ⑤ Retry Queue (List of failed transmissions) icon
- ⑥ Connection status of the external device (barcode reader)
- ⑦ Connection status of the external device (USB memory)
- ⑧ Network connection status: Touch this button to set the network.
- ⑨ Battery status or AC power connection status
- ⑩ Current date and time: Touch this button to set the date and time.
- ⑪ Multi-option button
- ⑫ Print Button
- ⑬ Delete Button
- ⑭ Preview Button

- ⑮ Patient information
- ⑯ Setup Menu Button
- ⑰ Touch this button to move to other menus such as ECG, Spiro, File, or Worklist.

2) Functions

Searching Files

Touch the magnifying glass button at the top left of the screen to enter a search condition.
Touch Search Item to enter ID, Name, Accession No., Age, and Date.



Select an item and enter the search condition.

When you select ID, Name, and Accession No., a text box where you can enter search text is displayed. Touch it to enter text using the keypad window.

If you search by age and date, a text box that allows you to enter a start and end number is displayed as shown below.

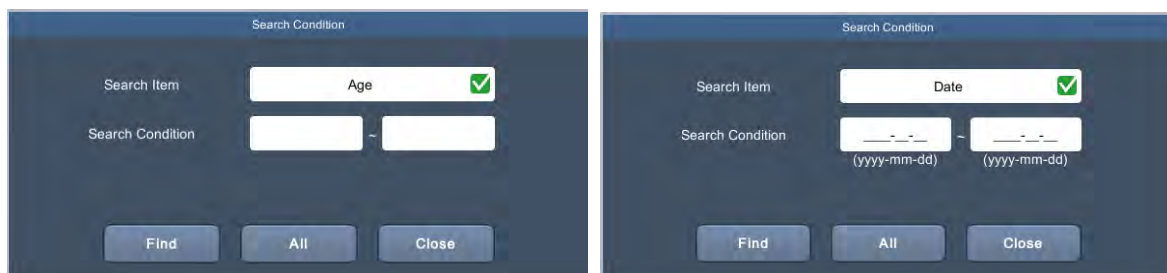

The fields front and back are the start and end range, respectively.

With no start range specified, files are searched from the first to the end range.

With no end range specified, files are searched from the start range to the last.

Selecting Files (Select)

Touch to select a file.

To select multiple files, touch [Select] and then touch the checkboxes in front of the IDs.

To select all files, touch the  button shown in the title bar of the file list.

	ID	Name	Sex	Age	DateTime	Study
11	<input type="checkbox"/>	testID1	Name	M	51yr	2022-02-08 15:... LTECG
12	<input checked="" type="checkbox"/>	testID2	name	M	54yr	2022-02-08 15:... LTECG
13	<input type="checkbox"/>	testID3	Name	M	21yr	2022-02-08 15:... LTECG
14	<input type="checkbox"/>	testID4	Demo	M	99yr	2022-02-08 15:... LTECG
15	<input checked="" type="checkbox"/>	testID5	LastName	M	66yr	2022-02-08 15:... LTECG
16	<input checked="" type="checkbox"/>	testID6	FirstName	M	33yr	2022-02-08 15:... LTECG
17	<input type="checkbox"/>	testID7	LName	M	25yr	2022-02-08 15:... LTECG
18	<input checked="" type="checkbox"/>	testID8	NAME	M	77yr	2022-02-08 14:... LTECG
19	<input type="checkbox"/>	testID9	Name	M	51yr	2022-02-04 16:... LTECG
20	<input type="checkbox"/>	testID10	test	M	18yr	2022-02-04 16:... LTECG

Printing Files (Print)

Print the selected files.

You can print one or multiple files.

NOTE

Do not attempt to attach or detach a USB device while the printer is working as it may cause the printer module to rattle.

Deleting Files (Delete)

Delete the selected files. You can delete one or multiple files at a time.

NOTE

Care has to be taken as deleted data cannot be restored.

Viewing Files (View)

Preview the selected files.

Before printing them out, you can modify the speed, Gain, or Print Form in the preview screen.

Viewing Patient information (Patient)

View or modify the patient information in the selected files.

You cannot change the items that may affect the diagnosis.

NOTE

Bionet provides Adult diagnosis and Pediatric diagnosis.

* Bionet Algorithm - 3 years or older / Glasgow Algorithm - 0 years or older

3) Setup

Touch [Setup] to open File General Setup screen as shown below.

General Setup



Barcode Search

Select the item to search using a barcode reader among ID, Name, and Accession No.

Display Table item

Set the items to be shown on the File main screen.

Changing display items triggers auto-adjustment of spacing between them.

Removing Old Files

Set whether to delete files between Manual and Auto when the internal memory of Cardio Q50 / Cardio Q70 is full.

- Manual: Delete files yourself.
- Auto: Files with the oldest date are automatically deleted.

NOTE

In the Manual setting, a warning message appears if you finish saving when the storage capacity is almost full (more than 490 data). If you try to save when the capacity is full (500), a warning or error message appears.

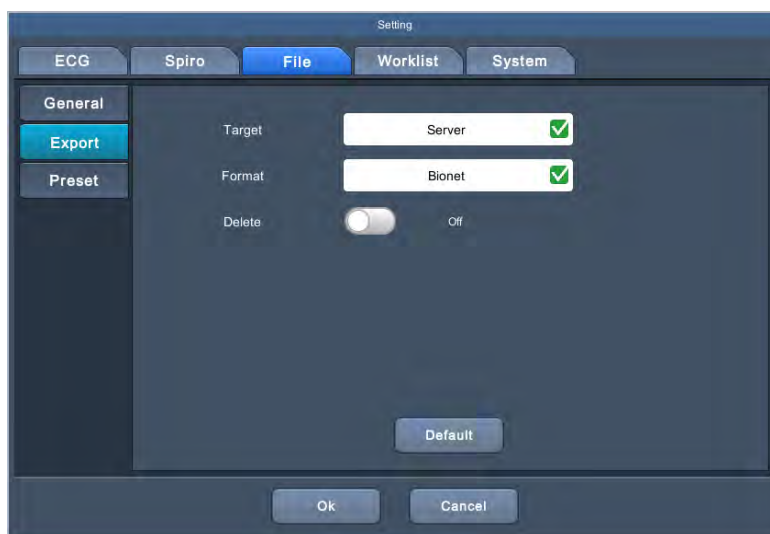
Exporting Files**Sending Media (Target)**

Press the [AUTO] key on the control panel to set the target to transfer files between USB memory and server.

File Format (Format)

Set the format of the files to transfer.

Choose from: Bionet formats, Dicom, PDF, MFER, XML, BMP, JPG, and old Bionet.

NOTE

- The Bionet format of the Cardio Q50 / Cardio Q70 supports Json format. Format to be compatible in other ECG equipment of Bionet shall be designated as old Bionet.
- The old Bionet format only supports 10-second resting ECG, FVC base test (3 counts) and post test, SVC test, and MVV tests.
- MFER, XML and Dicom of RAW image format can only support 10 seconds resting ECG.

Deleting Files

Set whether or not to delete the files on Cardio Q50 / Cardio Q70 after they are transferred to the server. To delete, set it to On.

NOTE

The Delete option applies only when files are sent to the server. Files sent to USB memory are not deleted.

Preset Settings



Image Size

Designate image size of format of JPG or BMP (including when image format of Dicom is JPG or BMP)

Creating Dicom Files

Set the format of the Dicom files.

Type	Description
RGB Format	Since each PACS system has a different RGB system, image colors may be represented differently. If the ECG exam paper grid appears green in the PACS viewer, set the RGB Format to BGR.
Image Format	Set the image format of Dicom files among PDF, BMP, JPG, and RAW.

Window Width / Window Center	On PACS system, Window Width and Center are usually set to their default values. If the images in the transmitted files are blurry, enter the Window Width and Center values that the PACS server supports.
------------------------------	---

Security Options (Hide Information)

Set to Hide for security purposes to screen the file information when printing or transferring files of all formats. Information set to be hidden is shown as hidden texts (*').

- Patient Name: Set it to Hide to screen the patient name.
- Hospital Info: Set it to Hide to screen the name of the hospital and doctor.

ECG Analysis Options

Set whether to state the diagnostic results for files of all formats that are printed and transferred. Information set to Hide is shown as blank.

Type	Description
Parameters	Set whether to hide parameter information.
Diagnosis	Set whether to hide the diagnosis name.
HRV	Set whether to hide HRV parameter.
Diagnosis Caps Lock	When it is set to On, the diagnosis is stated in uppercase. This function is available only when the language is set to English.

NOTE

HRV can make a diagnosis only for a recording longer than 3 minutes.

File Autokey Setup

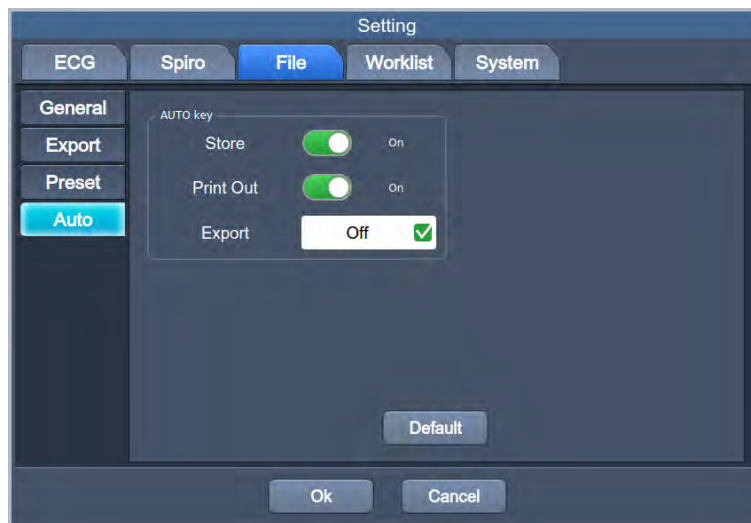

AUTO Key

Set AUTO Key function such as storing, printing, and transmitting as below.

Saving Results (Store)

Set whether to save the test data.

To save the test result automatically in the internal memory, set it to On. Otherwise, set it to Off. Check the saved data in the File main screen.

Printing Results (Print out)

Set whether to print out the test data.

To print the test result, set it to On. Otherwise, set it to Off.

Exporting Results (Export)

Set whether to transmit the test data to USB memory or external devices.

- Off: Data is not sent.
- Server: Data is sent to the server.
- USB: Data is sent to USB memory.

NOTE

When removing the external device or USB memory after transferring data to them, be sure to touch the  (external device icon) at the top of the main screen first. Otherwise, the saved data may be damaged.

NOTE

- Cardio Q50 / Cardio Q70 supports up to 64GB USB memory.
- Bionet recommends using the products of manufacturers below:
SanDisk, PNY, Transcend, and Samsung
- Bionet recommends backing up data on an existing storage device before connecting a new storage device.
- The file format of USB memory supported by Cardio Q50 / Cardio Q70 is FAT32.
- USB external HDD is not supported.
- Some high power USB devices may not be supported.

4) Transmitting Data (NETWORK)

On the file screen, press the [AUTO] key on the control panel to export the saved data to the connected external device.

Press the [AUTO] key on the control panel to transmit the selected data. On the Retry Queue screen, check the transmissions that failed due to network errors.

The following is the Retry Queue main screen.

ID	Name	DateTime	Study
1	10sec	2019-04-08 11:05:30	ECG
2	10sec	2019-04-08 11:05:30	ECG
3	1min	2019-04-08 11:07:06	LTECG
4	1min	2019-04-08 11:07:06	LTECG
5	3min	2019-04-08 11:10:14	LTECG
6	5min	2019-04-08 11:16:50	LTECG
7	10min	2019-04-09 10:05:09	LTECG
8	10min	2019-04-09 10:05:09	LTECG
9	22356780	2019-04-09 13:24:00	SFVC
10	22356780	2019-04-09 13:48:18	FVC+

Check the Retry Queue listing failed transmissions and resend them.

4) Importing Data

On the file screen, press the [COPY] key on the control panel to import the data in Bionet format saved in the USB memory to equipment.

Press the [COPY] key on the control panel: the following screen appears.

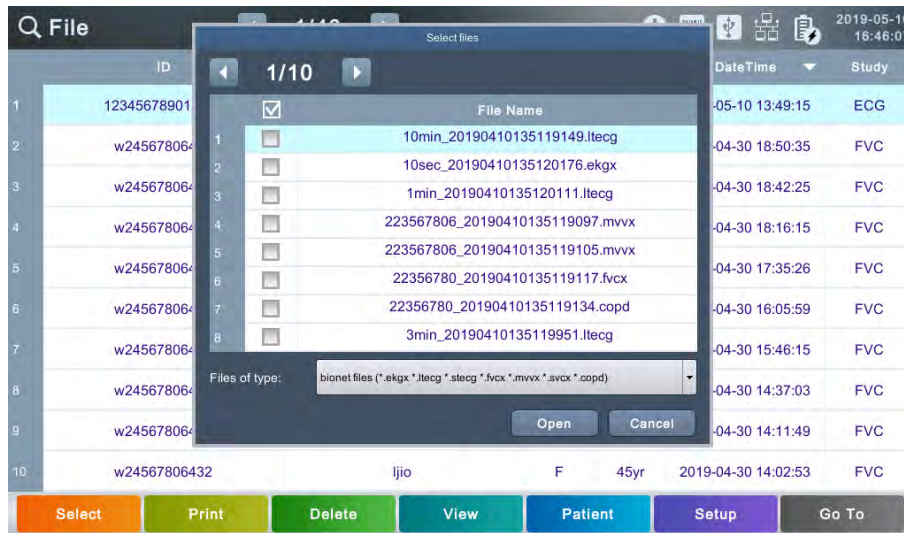

Select the data to import and touch [OPEN].

NOTE

Only the files in following formats can be imported:

➔ ekgx, ltecg, stecg, fcx, mvvx, svcx, sfvc

Chapter 7. User Information Management

1) Screen Description

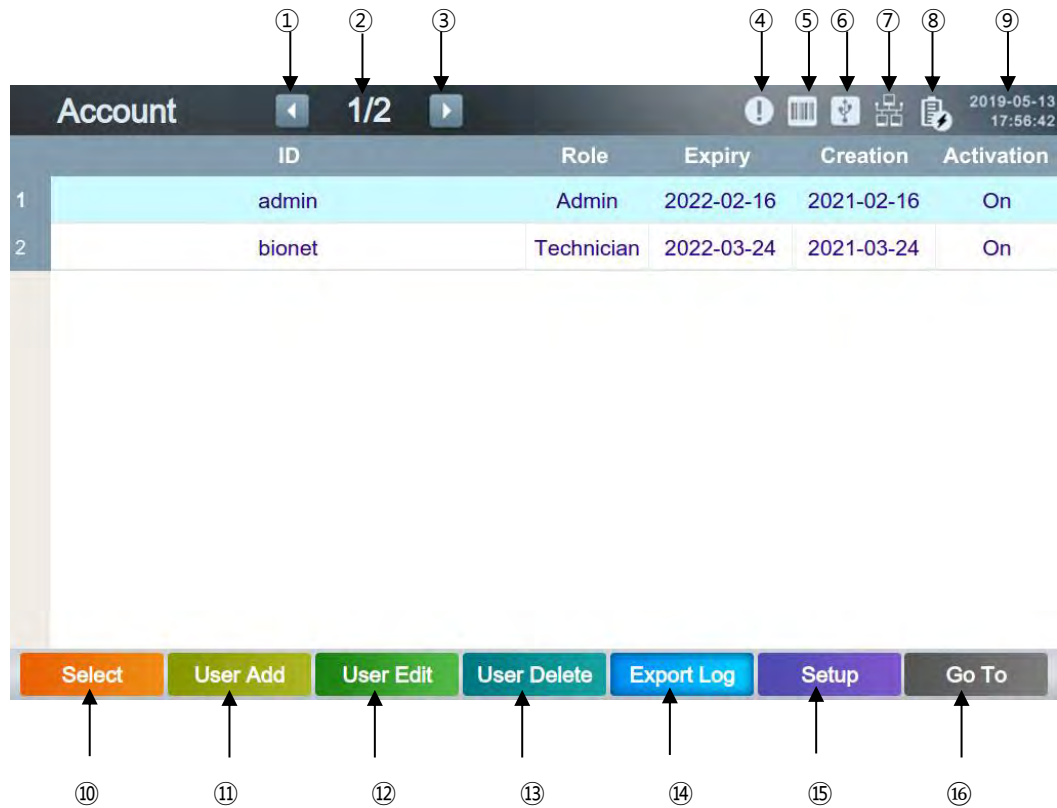

- ① Go to the previous page.
- ② Current page/total number of file pages
- ③ Go to the next page.
- ④ Retry Queue (List of failed transmissions) icon
- ⑤ Connection status of the external device (barcode reader)
- ⑥ Connection status of the external device (USB memory)
- ⑦ Network connection status: Touch this button to set the network.
- ⑧ Battery status or AC power connection status
- ⑨ Current date and time: Touch this button to set the date and time.
- ⑩ Multi-option button
- ⑪ Adding a User button
- ⑫ Editing a User button
- ⑬ Deleting a User button
- ⑭ Exporting Logs button
- ⑮ Setup Menu
- ⑯ Touch this button to move to other menus such as ECG, Spiro, File, or Worklist.

2) Functions

To select multiple users, touch [Select] and then touch the checkboxes in front of the IDs.

To select all users, touch button shown in the title bar of the user list.

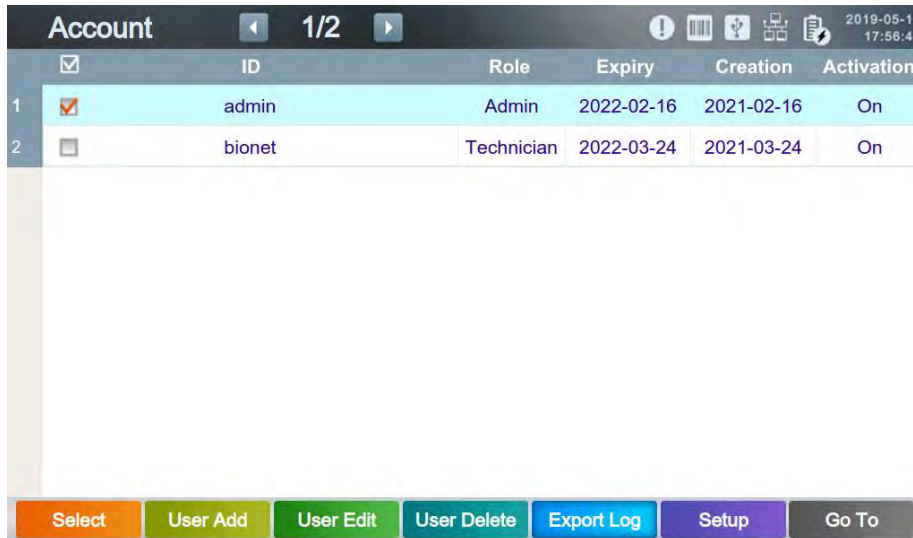

Selecting a User

Touch the user list to select users.

Adding a User (User Add)

Touch this button to add a user.

- ID: Add a user ID.
- Validity: Set the expiration date for the user account.
- Role: Enter user permission. Admin has authority over all functions, including system settings, diagnosis settings, scans, and general settings.
- Physician has authority over diagnostic settings, tests and general settings. Technician has authority over tests and general settings.

- Activation: Set whether to activate the user account.
- Password: Enter the user password.

NOTE**Rules for Creating Passwords**

- 10 or more characters: a combination of two of uppercase letters, lowercase letters, numbers, and special characters.
- 8 or more characters: 3 combinations of uppercase letters, lowercase letters, numbers, and special characters.

Editing a User (User Edit)

Touch this button to edit the selected users.

Deleting a User

Touch this button to delete the selected users.

Exporting Logs

Transmit the measured logs to USB memory.

NOTE

When removing the external device or USB memory after transferring data to them, be sure to touch the  (external device icon) at the top of the main screen first. Otherwise, the saved data may be damaged.

NOTE

- Cardio Q50 / Cardio Q70 supports up to 64GB USB memory.
- Bionet recommends using the products of manufacturers below:
SanDisk, PNY, Transcend, and Samsung
- Bionet recommends backing up data on an existing storage device before connecting a new storage device.
- The file format of USB memory supported by Cardio Q50 / Cardio Q70 is FAT32.
- USB external HDD is not supported.
- Some high power USB devices may not be supported.

Chapter 8. System Management

1) Maintenance and Cleanliness

Keep Cardio Q50 / Cardio Q70 equipment and handles clean. Avoid damaging or contaminating the equipment using the methods recommended below.

If you use the substances - including not allowed substances - that can damage on the product, warranty is not applied even during the warranty period.

NOTE
Clean the equipment and examine the body and electrodes thoroughly. Do not use old or damaged equipment.

At least once a month, wipe the body and measuring electrodes with a soft cloth moistened with alcohol to keep them clean. Do not use lacquer, thinner, ethylene, or oxide. Keep cables and limb and chest electrodes free of dust and dirt, and wipe them with a cloth dampened in lukewarm water (40°C/104°F) after use. Wipe them with clinical grade alcohol at least once a week. Do not immerse equipment or ECG wires in liquids or detergents. Keep the equipment and cables away from liquids.

NOTE
If the equipment is determined to be visibly unclean at the end of the cleaning steps, you should repeat the relevant previous cleaning process.

NOTE
If the equipment experiences unacceptable deterioration, such as corrosion, discoloration, dents, or cracked seals, contact the seller where you purchased the equipment and follow his or her instructions whether to dispose of or repair it.

Existing Device Disposal

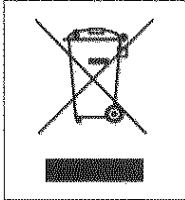

1. Products bearing this symbol (X-marked wheeled bins) are subject to European Directive 2002/96/EC.
2. All electrical and electronic products must be disposed of separately from municipal waste at the collection facility designated by government or local authorities.
3. Proper disposal of old devices helps prevent potential adverse consequences against environmental and human health.
4. For more information on the disposal of existing devices, contact City Hall, Waste Disposal Service Center, or the store where you purchased the product.

2) Regular Examination

As with any other medical equipment, have your Cardio Q50 / Cardio Q70 regularly safety inspected once a year. Refer to the service manual provided by Bionet for inspection items.

3) Simple Troubleshooting

- **Paper jam:**

: Press and hold the [ESC] key to stop printing immediately.

Open the printer tray and remove the paper that has been rolled into.

Paper jams or wrinkles may occur if you do not place the paper correctly on the printer tray or if you tear it in the wrong way.

- **When a buzzer sounds and the battery icon at the top right of the screen flickers in batter power mode**

: Battery is very low. Connect the AC power.

- **The screen flickers when you turn on the equipment**

: Battery is almost dead. Connect the AC power.

- **If there is a lot of noise in the output signal**

: Check if AC power filter is set. If the noise is persistent even though the AC power filter is set, connect the ground wire to the ground electrode of the system.

Do not connect the grounding to that of AC power source, but to the metal connected to the surrounding patient's bed or building.

- **Cyber security Issues**

- 1) If equipment is stolen or lost, contact the hospital staff or manufacturer as soon as possible.

When a stolen or lost equipment report is filed, the hospital network administrator must take steps to prevent the equipment from accessing the hospital network.

- 2) If a cyber security threat is detected while using the equipment, immediately disconnect it from the network and contact the hospital staff or manufacturer.

※ **For manufacturer contact information, please refer to the table of contents for How to Contact Us.**

- **When touch sensitivity is poor**

: Calibrate the touch screen.

Calibrate the touch screen in Setup -> System -> General -> Touch -> Calibration.

Turn off and on the equipment if you are unable to run Calibration.

If you see the following message in a yellow square when booting the equipment, press the [COPY] key to run the touch screen calibration.

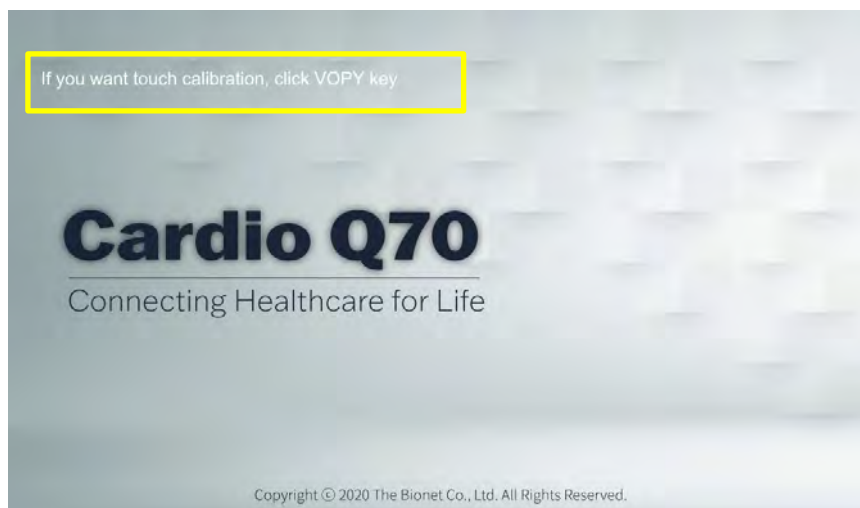

System Messages

ECG			
No.	Message	Cause	Solution
1	Date of birth is not valid.	Appears when you enter the patient's date of birth as invalid.	Enter the patient's date of birth in the correct format.
2	Please enter patient ID	Appears when patient ID is not registered during AUTO key execution.	Enter the patient ID and relevant information in Patient Information window.
3	No ECG Recorded Data !!!	Appears if no previous test result is found during COPY key execution.	Examine the patient again, or check if there is a saved file on the File menu.
4	Not Supported 100 mm/sec	Indicates that 100 mm/sec speed is not supported for real-time printing driven by RHYTHM key.	The speed of real-time printing is supported only up to 50mm/sec. Change the printing speed and try again.
5	Failed Saving	Appears when saving fails during AUTO key execution.	If data is full on the file, delete some amount. Based on the 10-second resting ECG, up to 500 files can be saved.
6	Failed Printing	Appears if printing fails during AUTO key execution.	Check the paper status and try again. Press the [COPY] key to print again the same result.
7	Failed Sending	Appears when transmission to the server fails during AUTO key execution.	Check the network status and try again. Check the List of failed transmissions and resend.
8	Failed Exporting	Appears when exporting a file to USB memory fails during AUTO key execution.	Check the USB memory and try again.
9	Processing is canceled	Appears if you cancel the operation during AUTO key execution.	

10	Failed To Start Shuma	Appears when an error occurs in auto diagnosis during AUTO key execution.	Check if the patient cables are normal and the ECG signal is clear, then try again.
11	Current study mode does not support exporting files. [Unsupported file format]	Appears when the file study to send is set to be a format that is not supported.	LTECG does not support old format. Change it to a supported format and try again.
Worklist			
No.	Message	Cause	Solution
1	Date of birth is not valid.	Appears when you enter the patient's date of birth as invalid.	Enter the patient's date of birth in the correct format.
2	No search results.	Appears when there is no target data to search for.	Enter the search condition correctly.
3	Please check the modality information.	Appears when there is no corresponding list for the modality of the worklist you have requested to the PACS server using the [Update] button.	Make sure that the modality of the PACS server and the settings of the equipment are the same, and try again.
4	No worklist.	Appears when there is no worklist you have requested to the PACS server using the [Update] button.	Make sure that the Date Range in the worklist and the system date is correct, and try again.
5	Fail to update worklist.	Appears when the worklist request - run by Update button - to the PACS server fails.	Check the network status or the settings of the worklist server and try again.
6	Fail to remove "COUNT" files	Appears if the selected files fail to be deleted.	Please try again. Care has to be taken as deleted data cannot be restored.
7	Canceled	Appears if you cancel the operation in progress.	
File			
No.	Message	Cause	Solution

1	Please change the export format settings. [List of unsupported file formats]	Appears when the transmission list includes files in an unsupported format.	Only the files with the supported format can be transferred. Change the unsupported format to a supported format and try again. LTECG does not support old format.
2	No search results.	Appears when there is no target data to search for.	Enter the search condition correctly.
3	Fail to Printing	Appears if printing fails.	Check the paper status and try again.
4	Fail to Sending	Appears if the transfer fails.	Check the network status or the settings of the worklist server and try again. Check the List of Failed Transmissions and retry.
5	Fail to Exporting	Appears when exporting a file to USB memory fails.	Check the USB memory and try again.
6	Fail to Importing	Appears if copying the files saved in USB memory to equipment fails.	Check the USB memory and try again.
7	This file format cannot be imported.	Appears when any of the files stored in the USB memory cannot be copied to the equipment.	Check the format of files stored in the USB memory and try again.
8	Fail to remove	Appears if the files fail to be deleted.	Select the files to delete again and try again. Care has to be taken as deleted data cannot be restored.
9	Not Supported Study	Appears when the preview of the file is not supported.	Make sure the file is saved correctly.
10	After connect storage, try again.	Appears when a USB memory is not plugged or it is defective when files are exported to it.	Check if the USB memory is intact, and plug it well and try again.

11	Preview speed is fixed at "SPEED" Preview gain is fixed at "GAIN"	Informs that in the preview of long-term ECG diagnosis, the Gain and Speed are shown as fixed values regardless of the setting.	Fixed values are only seen in the screen preview. Printing is done according to the set value.
12	Preview speed is fixed at 25 mm/sec	Informs that in the preview the Speed is fixed at 25 mm/sec regardless of the setting.	Fixed values are only seen in the screen preview. Printing is done according to the set value.
Retry Queue			
No.	Message	Cause	Solution
1	Please change the export format settings. [List of unsupported file formats]	Appears when the transmission list includes files in an unsupported format.	Only the files with the supported format can be transferred. Change the unsupported format to a supported format and try again. LTECG does not support old format.
2	Fail to Sending	Appears when a transmission from the List of failed transmissions (Retry Queue) to the server fails.	Check the network status or the settings of the worklist server and try again.
3	Fail to remove	Appears when deleting data from the List of failed transmissions (Retry Queue) fails.	Select the files to delete again and try again. When deleted from the Retry Queue, they are deleted only from the Retry Queue list and not from the File list that manages saved files.
4	Complete	Appears when the operation is successfully done.	
5	Canceled	Appears if you cancel the operation in progress.	
Setup			
No.	Message	Cause	Solution

1	You cannot change the current date & time as earlier date & time than "MIN TIME". Please try again!	Appears on system time change when the time entered precedes the minimum time.	Enter the time correctly.
2	You cannot change the current date & time as later date & time than "MAX TIME" Please try again!	Appears on system time change when the time entered is behind the maximum time.	Enter the time correctly.
3	Please press once at each of the marks shown in the next screen. This message box will timeout after 5 seconds if you are unable to close it.	Appears when calibration starts.	Touch [Close] or wait for 5 seconds to make it disappeared automatically. When the window closes, tab the calibration pointer (X) with the calibration pen following the instruction.
4	Please check wifi device.	Appears when wireless LAN card is not detected or when the wireless network is set up incorrectly.	Check wireless LAN card.
5	Please try again later	Appears when an error occurs getting the list of APs on the wireless network.	Check the wireless LAN card or network configuration.
6	Insert password	Appears when you do not enter a password while trying to connect an AP that requires authentication.	Enter a correct AP password.
7	Invalid network IP	Appears when an IP address is invalid.	Enter a correct IP address.
8	Invalid subnet mask	Appears when a subnet mask is invalid.	Enter a correct subnet mask.
9	Invalid gateway IP	Appears when a gateway IP address is invalid.	Enter a correct gateway IP address.

10	Ping canceled	Appears in Server Settings if you canceled the connection test with the server on the setup screen.	
11	Ping failed	Appears when the connection test with the server fails.	Check the server IP or network status, and try again.
12	Ping succeeded	Appears when the connection test to the server succeeds.	
13	Invalid server IP	Appears when the server IP address is invalid.	Enter a correct IP address.
14	Succeeded	Appears when the connection test to the PACS server succeeds.	
15	Failed	Appears when the connection test to the PACS server fails.	Check the PACS server IP or network status, and try again.
16	Invalid PACS server worklist IP	Appears when the worklist server IP address of PACS is invalid.	Enter a correct IP address of worklist server.
17	Invalid PACS server store IP	Appears when the Store server IP address of PACS is invalid.	Enter a correct IP address of Store server.
18	You have a wrong password. Please enter again.	Appears when the password is wrong on a menu that requires authentication.	Enter the correct password.
19	New password and confirm password are different. Please enter again.	Appears if the password and confirm password field value do not match.	Enter a new password correctly.
20	New password or confirm password are empty. Please enter again.	Appears if either the password or confirm password field value is empty.	Enter a new password correctly.

21	The system changed user password successfully.	Indicates that the password is changed successfully.	Save the changed password well.
22	The system is made into factory default.	Appears when you initialize all settings to factory default mode. Indicates that all settings have been reset.	Care has to be taken as initialized setup cannot be restored.
23	The system erased all data.	Appears when you delete all data files on the equipment. Indicates that all files have been deleted.	Care has to be taken as initialized files cannot be restored.
24	No upgrade software found.	Appears when upgrade software is not found in USB memory.	Save the upgrade software to USB memory.
25	No License Writer software found.	Indicates that there is no license registered software when registering license.	Save license registration software on the USB memory.
26	"HH:HH:HH:HH:HH:HH"	Appears when the MAC address is invalid.	Enter a valid MAC address.
27	MAC address exist	Appears when the MAC address is duplicate.	Enter a valid MAC address.
28	The system wrote mac address successfully.	Indicates that the MAC address is registered.	Since MAC address cannot be changed, double-check the validity of the address.
Others			
No.	Message	Cause	Solution
1	Data Saving and Power off...	Indicates the equipment will be off when data and settings are saved.	Wait for a while until the power turns off.
2	Time has been reset. Please check coin battery.	Appears when the coin battery is discharged. The date is displayed on the equipment as 2000-01-01.	Please contact Bionet's service team to exchange the coin battery.
3	Unrecognized "USB"	Appears when the attached USB memory is not	Make sure that the USB memory is intact.

		recognized by the equipment.	This equipment only supports the FAT32 file format.
4	Exception occurred.	Appears when there occurs a mounting error on the attached USB memory or when unmounting fails.	Make sure that the USB memory is intact.
5	Unsupported Devices	Appears when an unsupported USB device is plugged in.	Make sure that the USB memory is intact.
6	Check device	Appears when there is a problem with the attached USB memory.	Make sure that the USB memory is intact.
7	Complete	Appears when the operation is successfully done.	
8	Canceled	Appears if you cancel the operation in progress.	
9	Battery low. Please connect to external power supply	Appears when the battery has been discharged.	Connect it to a power source until it is fully charged.

Please contact A/S center of Bionet if issue has not been solved with solution above.

4) Manufacturer's Declaration

Electromagnetic compatibility - Guidance and manufacturer's declaration

Guidance and manufacturer's declaration – electromagnetic emissions		
<p>The Cardio Q50 / Cardio Q70 is intended for use in the electromagnetic environment specified below.</p> <p>The customer or the user of the Cardio Q50 / Cardio Q70 should assure that it is used in such an environment.</p>		
Emissions test	Compliance	Electromagnetic environment - guidance
Mains terminal disturbance voltage CISPR 11	Group 1 Class A	The EMISSIONS characteristics of Cardio Q70 make it suitable for use in industrial areas and hospitals (CISPR 11 class A). If it is used in a residential environment (for which CISPR 11 class B is normally required) this equipment might not offer adequate protection to radio-frequency communication services. The user might need to take mitigation measures, such as relocating or re-orienting the equipment.
Radiated disturbance CISPR 11	Group1, Class A	
Harmonics IEC 61000-3-2	Class A	<p>The Cardio Q70 is suitable for use in all establishments other than domestic, and may be used in domestic establishments and those directly connected to the public low-voltage power supply network that supplies buildings used for domestic purposes, provided the following warning is heeded:</p> <p>Warning: This equipment/system is intended for use by healthcare professionals only.</p> <p>This equipment/ system may cause radio interference or may disrupt the operation of nearby equipment. It may be necessary to take mitigation measures, such as re-orienting or relocating the Cardio Q70 or shielding the location</p>
Voltage fluctuations/Flicker IEC 61000-3-3	Complies	

Guidance and manufacturer's declaration – electromagnetic immunity			
<p>The Cardio Q50 / Cardio Q70 is intended for use in the electromagnetic environment specified below.</p> <p>The customer or the user of the Cardio Q50 / Cardio Q70 should assure that it is used in such an environment.</p>			
IMMUNITY test	IEC 60601 test level	Compliance level	Electromagnetic environment - guidance
Electrostatic Discharge Immunity (ESD) IEC 61000-4-2	± 8 kV/Contact $\pm 2, \pm 4, \pm 8, \pm 15$ kV/Air	± 8 kV/Contact $\pm 2, \pm 4, \pm 8, \pm 15$ kV/Air	Floors should be wood, concrete or ceramic tile. If floors are covered with synthetic material, the relative humidity should be at least 30 %.
Radiated RF Electromagnetic Field Immunity IEC 61000-4-3	3 V/m 80 MHz - 2.7 GHz 80% AM at 1 kHz	3 V/m 80 MHz - 2.7 GHz 80% AM at 1 kHz	Cardio Q70 is suitable to use in professional healthcare environment.
Immunity to Proximity Fields from RF wireless Communications Equipment IEC 61000-4-3	28 V/m Max. 385-5785 MHz in according to table 9 in IEC 60601-1-2	28 V/m Max. 385-5785 MHz in according to table 9 in IEC 60601-1-2	RF communication equipment is used no closer than 30 cm to any part of the Cardio Q70, including cables specified by Bionet.
Electrical Fast Transient/Burst Immunity IEC 61000-4-4	± 2 kV, 100 kHz repetition frequency	± 2 kV, 100 kHz repetition frequency	The quality of supplied power should be suitable for general business site or hospital environment.
Surge IEC 61000-4-5	Line to Line ± 0.5 kV, ± 1 kV Line to Ground ± 0.5 kV, ± 1 kV, ± 2 kV	Line to Line ± 0.5 kV, ± 1 kV Line to Ground ± 0.5 kV, ± 1 kV, ± 2 kV	The quality of supplied power should be suitable for general business site or hospital environment.

Immunity to Conducted Disturbances Induced by RF fields IEC 61000-4-6	3 V 0.15 MHz - 80 MHz 6 V in ISM bands between 0.15 MHz and 80 MHz 80% AM at 1 kHz	3 V 0.15 MHz - 80 MHz 6 V in ISM bands between 0.15 MHz and 80 MHz 80% AM at 1 kHz	The strength of RF field in the frequency range higher than 150kHz~80MHz, the strength of the RF field is smaller than 3 V
Power Frequency Magnetic Field Immunity IEC 61000-4-8	30 A/m 50 & 60 Hz	30 A/m 50 & 60 Hz	Power frequency magnetic fields should be at levels characteristic of a typical location in a typical domestic, residential or Home Health Care environment.
Voltage dips IEC 61000-4-11*	0 % U_T ; 0.5 cycle At 0°, 45°, 90°, 135°, 180°, 225°, 270° and 315° 0 % U_T ; 1 cycle and 70 % U_T ; 30 cycles Single phase: at 0°	0 % U_T ; 0.5 cycle At 0°, 45°, 90°, 135°, 180°, 225°, 270° and 315° 0 % U_T ; 1 cycle and 70 % U_T ; 30 cycles Single phase: at 0°	Mains power quality should be that of a typical residential or hospital environment. If the user of the Cardio Q70 requires continued operation during power mains interruptions, it is recommended that the Cardio Q70 be powered from an uninterruptible power supply or a battery be used with the system power source.
Short interruptions IEC 61000-4-11*	0 % U_T ; 250/300 cycles	0 % U_T ; 250/300 cycles	
Radiated fields in close proximity IEC 61000-4-39	65 A/m Max 30 kHz - 13.56 MHz in according to table 11 in IEC 60601-1-2	65 A/m Max 30 kHz - 13.56 MHz in according to table 11 in IEC 60601-1-2	Cardio Q70 is suitable to use in professional healthcare environment. Portable radio frequency (RF, RFID) communication devices can interfere with

			the medical electrical device. Therefore, do not use your mobile phone in a medical office or hospital environment.
*Note: U_T is the AC voltage of the power before using test level			

Chapter 9. Product Specifications

ECG	
ECG Leads	Simultaneous 12 channel ECG and acquisition
Recording Channel	3CH+3RHY, 3CH+1RHY, 6CH+1RHY, 12CH, 1CH+3, Cabrera Report 1CH Long Time (1min, 3min, 5min, 10min, 20min, 30min) and Special Beat Report (Text, Guide, Vector)
Gain	2.5, 5, 10, 20, Auto (I~aVF: 10, V1~V6: 5) mm/mV
Printing Speed	5, 12.5, 25, 50, 100 mm/sec
Sampling Rate	Analysis Sampling Rate - 500Hz Digital Sampling Rate - 8,000Hz
Filters	AC (50/60 Hz, -20dB or better), Muscle (25~35Hz, -3dB or better), Bionet Baseline Drift (0.05Hz, 0.1Hz, 0.2Hz, -3dB or better) Low Pass Filter (off, 40Hz, 100Hz, 150Hz)
Patient Data	ID, Name, Date of Birth, Age, Gender, Height, Weight, Race, Smoke, Department, Room No., Study Desc., Accession No., Referring Physician
Basic Measurement & Interpretation	Heart Rate (30~300bpm, ± 3 bpm), PR/RR Int, QRS Dur, QT/QTc Int, P-R-T axis, SV1/RV5/R+S Amp Bionet ECG analysis algorithm The University of Glasgow ECG analysis algorithm
Electrical	Internal Noise : 20uV(p-p)max Input Impedance : $\geq 50M\Omega$ Input Voltage Range : ± 5 mV CMRR : > 105 dB DC Offset Voltage : $\geq \pm 400$ mV Patient Leakage Current : < 10 uA Frequency Response : 0.05~200 with in -3 dB Isolated, Defibrillation and ESU Protected
Signal Quality Control	Pacemaker Pulse Detection Lead Fault Detection, Signal Saturation Detection
Spiro	

Measuring Values	<ul style="list-style-type: none"> - FVC : FVC, FEV1, FEV1/FVC, FEF 0.2-1.2L, FEF 25-75%, FEF 75-85%, PEF, FEF 25%, FEF 50%, FEF 75%, FIVC, FEV6, PEFT, FET 100%, Error Code, Extrapolation volume - FEV1/FEV6 : FEV1, FEV6, FEV1/FEV6, LFI - SVC : SVC, TV, ERV, IRV, EC - MVV : MVV, FB, TV
Presentation	<p>Flow Volume Loop</p> <p>Volume Time Graph</p> <p>Measurement Values Table</p>
Measuring Range	<p>Flow: 0 to ± 14 L/s</p> <p>Volume: 0 to ± 12 L</p>
Measuring Method	Differential Pressure Method
Prediction Equation	Morris-Polgar, Knudson-ITS, ECCS-Quanjer, Korea CJK, Pereira, GLI-2012
Sample Rate	200 samples/sec
Flow Impedance	< 0.2 mbar s/L at 12 L/s
Measuring Accuracy	Complies with ISO 26782, ISO 23747
Common	
Data Storage	Internal Storage for 500 Data : Built- in Memory
Display	10.1" (8") Color TFT Wide Display (1024 x 600), 12 Channels Preview ECG Wave
User Interface	Touch Screen (Alphanumeric and Symbol Available), Function Keys, Keyboard (Option)
Printer Resolution	<p>Thermal Print Head, Z-fold Paper</p> <p>Report Paper</p> <ul style="list-style-type: none"> - A4: 210mm (8.3") x 300mm (11.8") - Letter: 215mm (8.5") x 280mm (11") <p>Paper Size</p> <ul style="list-style-type: none"> - A4: 210mm x 150mm (half A4) - Letter: 215mm x 140mm (half Letter) <p>Resolution</p> <ul style="list-style-type: none"> - Vertical: 8dot/mm - Horizontal: 16dot/mm (0.125mm pitch)

Line Power		Input: 100~240 VAC, 50/60Hz, 1.5~0.75A Output: 15 VDC, 4.2 A
Battery Type		Replaceable and Rechargeable Lithium Ion, 10.8V, 6500mA
Battery Capacity		10 hours of normal use or print 350 ECG (12 channel format at 25mm/s and 10mm/mV) or Spiro pages. Battery recharge to full capacity in 3 hours. (The device is turned off)
Communication		LAN, WIFI (Option), USB flash driver, USB barcode scanner
Safety Conformity		Class I, Type CF Applied Parts: ECG Electrodes Type B Applied Parts : Spirometer Handle
Environment	Operation	Ambient Temperature : 10 to 40°C Relative Humidity : 30 to 85% Atmospheric Pressure : 700 to 1060hPa
	Storage/Ship	Ambient Temperature : -20 to 60°C Relative Humidity : 10 to 95% Atmospheric Pressure : 500 to 1060hPa
Dimensions		Main Body - 286(W) x 350(D) x 140(H) mm (Cardio Q50) - 286(W) x 350(D) x 144(H) mm (Cardio Q70) - Approx. 4.5kg (Max) Spiro Handle - 48(W) x 39(D) x 201(H) mm - Approx. 250g
Standard Accessory		Patient Cable (1EA), Limb Electrodes (1SET), Chest Electrodes (1SET), ECG Recording Paper (1EA), AC Power Cord (1EA), ECG Gel (1EA), Operation Manual (1EA), ECG Diagnosis Guide (1EA)
Options		Battery - Replaceable and Rechargeable (1EA) Spiro Handle (1EA), Diagnostic Guide (1EA), Disposable mouthpiece (2EA), Nose Clip (1EA), Mouthpiece Adaptor(1EA), Handle supporter (1EA), Disposable Mouthpiece 1 box (100EA), PFT Filter (20EA), Calibration Syringe[3L] (1EA) Spiro Connector (1EA)

Additional Specification

<p>Wireless Function (Archer T2U AC600)</p>	<p>Wireless Standard: IEEE 802.11ac, IEEE 802.11a IEEE 802.11n, IEEE 802.11g, IEEE 802.11b</p> <p>Frequency: 5 GHz, 2.4 GHz</p> <p>Signal Speed (5 GHz)</p> <ul style="list-style-type: none"> - 11ac: Up to 433Mbps (Dynamic) - 11n: Up to 150Mbps (Dynamic) - 11a: Up to 54Mbps (Dynamic) <p>Signal Speed (2.4 GHz)</p> <ul style="list-style-type: none"> - 11n: Up to 150Mbps (Dynamic) - 11g: Up to 54Mbps (Dynamic) - 11b: Up to 11Mbps (Dynamic) <p>Receive Sensitivity (5 GHz)</p> <ul style="list-style-type: none"> - 11a 6Mbps: -94dBm - 11a 54Mbps: -78dBm - 11n HT20 MCS0: -94dBm - 11n HT20 MCS7: -77dBm - 11n HT40 MCS0: -92dBm - 11n HT40 MCS7: -74dBm - 11ac VHT80 MCS0: -89dBm - 11ac VHT80 MCS9: -64dBm <p>Receive Sensitivity (2.4 GHz)</p> <ul style="list-style-type: none"> - 11b 1Mbps: -99dBm - 11b 11Mbps: -91dBm - 11g 6Mbps: -94dBm - 11g 54Mbps: -77dBm - 11n HT20 MCS0: -95dBm - 11n HT20 MCS7: -76dBm - 11n HT40 MCS0: -92dBm - 11n HT40 MCS7: -73dBm <p>Transmission Strength: <20dBm (EIRP)</p> <p>Wireless Mode: Ad-Hoc / Infrastructure Mode</p> <p>Wireless Security: WEP, WPA/WPA2, WPA-PSK/WPA2-PSK</p> <p>Modulation Technology</p> <ul style="list-style-type: none"> - DBPSK, DQPSK, CCK, OFDM, 16-QAM, 64-QAM
---	---

WARNING

Do not touch patient cables or equipment when using a ventricular defibrillator.

WARNING

When connecting electrodes or patient cables, do not allow connectors to touch conductive parts or ground. In particular, when attaching the electrodes to the patient's body, make sure that they do not come into contact with conductive parts or the ground.

WARNING

Do not use the supplied ECG patient cables to measure respiration. They should be used for ECG measurement only.

CAUTION

For the electrode, use the same product as provided or a product with biocompatibility certified by international standards.

CAUTION

Cardio Q50 / Cardio Q70 should be used in the presence of a health care professional when used for patients who have undergone Cardiac Assist Device surgery.