

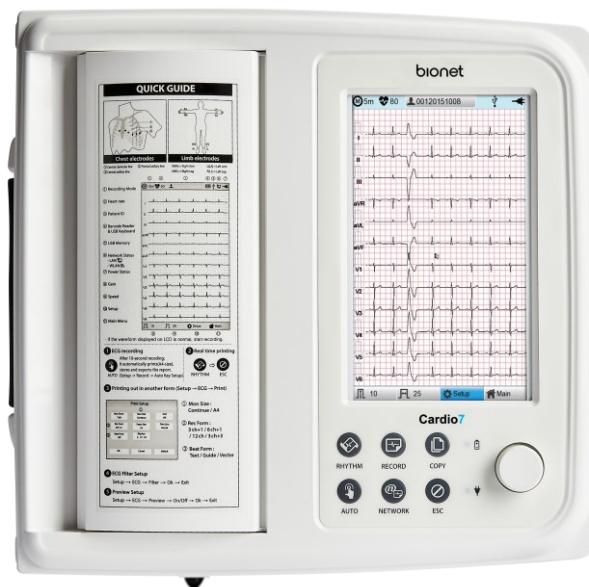

Electrocardiograph & Spirometer

Cardio7 Operation Manual



Ver. 1.37

2023.09.26



REVISION HISTORY

Revision No.	Date	Contents	Page
1.00	2015-12-24	1. Initial Release	All
		-	
1.35	2022-07-26	1. Added NTP warnings	75p
1.36	2023-02-27	1. Cardio7e and SpiroCare Manual Integration 2. Model name Cardio7 unified 3. Add Accessories 4. Table of Contents Summary 5. Specification crystal 6. Reflection of translation	All
1.37	2023.09.26	1. Changed Doc Number 2. Edit Copyright text 3. Apply the latest manual format	All

Caution
Federal law restricts this device to sale by or on the order of a physician

Note
The product does not have shelf life. Its expected use life is 10 years. After 10 years, though the product still works normally, it is recommended to have it checked by Bionet.

※ In the event of a malfunction or failure, contact Service Dept. Of Bionet Co., Ltd. along with the model name, serial number, date of purchase and explanation of failure.

Paid Services

A fee will be charged for all services except for breakdowns, so be sure to read this operation manual below before putting in a request.

<ul style="list-style-type: none"> - Usage description and simple inspection without disassembly - In case of reinstallation due to poor installation by a distributor 	<p>Free the 1st time Charged starting the 2nd time</p>
<ul style="list-style-type: none"> - Inadequate installation or loosening due to physical product movement, relocation, etc. - When re-installing after the first installation requested by the customer at the time of purchase - When reinstallation is required due to inexperienced installation by the customer - When a service is requested due to the input of foreign substances or improper cleaning 	<p>Charged starting the 1st time</p>

1. Equipment cleaning, adjustment, and usage description are not product breakdowns.

(Unfeasible repairs are subject to separate standards.)

2. Breakdowns caused by consumer negligence

Breakdowns and damage due to careless handling by the customer or incorrect repair are caused by:

- Using incompatible electric capacity.
- Mishaps such as dropping the product.
- Using the third party replacements or options not specified by our company.
- Non-Bionet technicians or agency technicians in the process of repair.

3. Other cases

- Breakdowns by natural disasters (fire, salt damage, flood damage, earthquake, etc.)
- When a consumable part has reached the end of its life (accessories)

Warnings, Cautions, and Notes

- The following terms are used throughout this manual to emphasize important and critical information. You must read these statements to help ensure safety and to prevent product damage.
- The manufacturer or the product distributor is not liable for any loss or damage to the product caused by incorrect use or negligence in product maintenance.

Warning

“Warning” Failure to follow this message may cause severe injuries, casualty or physical damage to patients.

Caution



“Caution” Failure to follow this message may cause in non-life-threatening injury or damage to the equipment.
--

Note

“Note” indicates some important information and tips, which are not dangerous, about installation, operations and maintenance.

General Precautions on Environment

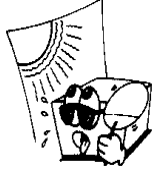
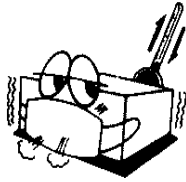
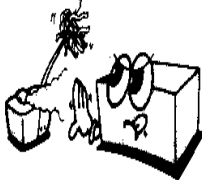
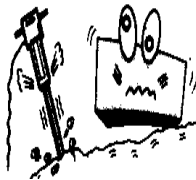
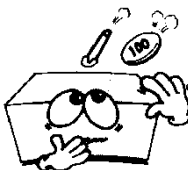
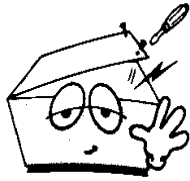
DO NOT store or operate the equipment in the places listed below.

	<p>A place exposed to moisture (DO NOT touch the equipment with wet hands.)</p>		<p>A place under direct sunlight</p>
	<p>A place in areas with highly fluctuating temperatures.</p>		<p>A place in the vicinity of Electric heater</p>
	<p>A place with excessive humidity rise or poor ventilation</p>		<p>A place with sources that cause excessive shock or vibration</p>
	<p>A place exposed to chemicals or at risk of gas leakage</p>		<p>Avoid the invasion of small objects/ particles such as dust, and especially avoid metallic material.</p>
	<p>DO NOT disjoint or disassemble the equipment. (Bionet is not liable for broken products caused by attempted disassembly.)</p>		<p>DO NOT connect power until the product is completely installed. It may cause damage to the product.</p>

Safety Instructions for Electricity

Please note the following precautions before using the product.

- Is the power supply cord proper? (100 - 240V AC)
- Is every cord connected properly to the product?
- Is the grounding connected correctly? (Otherwise, noise can occur.)
- There is a risk of electric shock if the Rest stand of the equipment is damaged or can not be fixed to the product. Do not use the product and immediately ask the manufacturer and the seller for repair

Classification.

- This device is classified as follows, in accordance with IEC60601-1.
- Its classification against electric shocks is Class I, Type CF defibrillation -proof applied part.
- Degree of protection against harmful ingress of water: Ordinary
- It is not proper to use this product near a flammable anesthetic or solvent.
- Continuous operation.
- IEC/EN60601-1-2 (Electromagnetic Compatibility Requirements) standard:

Classification	Description
Class A	The device or system is suitable for use in all establishments other than domestic and those directly connected to the public low-voltage power-supply network that supplies buildings used for domestic purposes. Mains power should be a typical commercial or hospital environment.

Note
Diagnosis provided by Cardio7 must be confirmed by a qualified medical professional.

Note
The EMISSIONS characteristics of this equipment make it suitable for use in industrial areas and hospitals (CISPR 11 class A). If it is used in a residential environment (for which CISPR

11 class B is normally required) this equipment might not offer adequate protection to radio-frequency communication services. The user might need to take mitigation measures, such as relocating or re-orienting the equipment.

Caution



Warning: MR Unsafe

Do not expose the device to a magnetic resonance (MR) environment.

- The device may present a risk of projectile injury due to the presence of ferromagnetic materials that can be attracted by the MR magnet core.
- Thermal injury and burns may occur due to the metal components of the device that can heat during MR scanning.
- The device may generate artifacts in the MR image.

The device may not function properly due to the strong magnetic and radiofrequency fields generated by the MR scanner.

Safety Messages

The following messages are applied throughout the product. Certain statements may also appear elsewhere in the manual.

Warning:

ACCIDENTAL SPILLS — If the equipment is penetrated with liquid, take it out of service and have it checked by a service technician before using it again.

DO NOT allow liquids to enter the equipment to prevent electric shock or equipment malfunction.

Warning:

BATTERY OPERATION - If the integrity of the electrical grounding is doubtful, use battery to operate the equipment.

Warning:

CABLES — To avoid possible strangulation, route all cables away from the patient's throat.

Warning:

CONNECTION TO MAINS — This is class I equipment.

The mains plug must be connected to an appropriate power supply.

Warning:

DEFIBRILLATOR PRECAUTIONS — Do not come into contact with patients during defibrillation. Otherwise, serious injury or death could result.

Patient signal inputs labeled with the CF symbols with paddles are protected against damage resulting from defibrillation voltages.

To ensure proper defibrillation protection, use only the recommended cables and lead-wires. Proper placement of defibrillator paddles in relation to the electrodes is required to ensure successful defibrillation.

Use only recommended cables and leads to ensure adequate defibrillation protection.

Warning:

ELECTRODES — Polarizing electrodes (stainless steel or silver constructed) may cause the electrodes to retain a residual charge after defibrillation. A residual charge will block acquisition of the ECG signal.

Whenever patient defibrillation is a possibility, use non-polarizing electrodes (silver or silver chloride construction) for ECG monitoring.

Warning:

MAGNETIC AND ELECTRICAL INTERFERENCE — Magnetic and electrical fields are capable of interfering with the proper performance of the device.

For this reason, make sure that all external devices operated in the vicinity of the device comply

with the relevant EMC requirements. X-ray equipment or MRI devices are possible sources of interference as they may emit higher levels of electromagnetic radiation.

Use of this equipment adjacent to or stacked with other equipment should be avoided because it could result in improper operation. If such use is necessary, this equipment and the other equipment should be observed to verify that they are operating normally.

Warning:

EXPLOSION HAZARD — Do NOT use in the presence of flammable anesthetics vapors or liquids.

Warning:

INTERPRETATION HAZARD — Computerized interpretation is only significant when used in conjunction with clinical findings.

A qualified physician must verify all computer-generated diagnoses.

Warning:

OPERATOR — Medical technical equipment such as this system must be used only by qualified and trained personnel.

Warning:

SHOCK HAZARD — Improper use of this device presents a shock hazard. Strictly observe the following guidelines. Failure to do so may endanger the lives of the patient, user, and bystanders.

When disconnecting the device from the power line, remove the plug from the wall outlet before disconnecting the cable from the device; otherwise, there is a risk of coming into contact with line voltage by inadvertently introducing metal parts in the sockets of the power cord.

Additional equipment connected to medical electrical equipment must comply with the respective IEC or ISO standards. (e.g. IEC 60950 for data processing equipment) Furthermore all configurations shall comply with the requirements for medical electrical systems. (See IEC 60601-1-2 or Clause 16 of IEC 60601-1) Anybody connecting additional equipment to medical electrical equipment configures a medical system and is therefore responsible that the system complies with the requirements for medical electrical systems.

Attention is drawn to the fact that local laws take priority over the above-mentioned requirements.

If in doubt, consult your local representative or the technical service department.

Warning:

SITE REQUIREMENTS — Improper placement of the device and/or accessories may result in a hazard to the patient, operator, or bystanders.

Do not route cables in a way that they may present a stumbling hazard.

For safety reasons, all connectors for patient cables and lead-wires are designed to prevent inadvertent disconnection, should someone pull on them.

For devices installed above the patient, adequate precautions must be taken to prevent them from dropping on the patient.

Warning:

TREADMILLS — Avoid rapid changes in treadmill speed and/or grade during a stress test.

Caution:

PROPER LEADWIRE CONNECTION — Improper connection will cause inaccuracies in the ECG. Trace each individual lead-wire from its acquisition module label to the colored connector and then to the proper electrode to ensure that it is matched to the correct label location.

Caution:

ACCESSORIES (SUPPLIES) — Parts and accessories used must meet the requirements of the applicable IEC 60601 series safety standards and essential performance standards, and/or the system configuration must meet the requirements of the IEC 60601–1–2 medical electrical systems standards.

Use of accessories, transducers and cables other than those specified or provided by the manufacturer of this equipment could result in increased electromagnetic emissions or decreased electromagnetic immunity of this equipment and result in improper operation.

Caution:

ACCESSORIES (EQUIPMENT) — The use of accessory equipment that does not comply with the equivalent safety requirements of this equipment may lead to a reduced level of safety of the resulting system.

Consideration relating to the choice of equipment shall include:

- Use of the accessory in the patient vicinity, and Evidence that the safety certification of the accessory has been performed in accordance with the appropriate IEC 60601–1 and/or IEC 60601–1–2 harmonized national standard.

Caution:

BATTERY POWER — If a device equipped with an optional battery pack will not be used or connected to the power line for a period of over six months, remove the battery.

Caution:

BEFORE INSTALLATION — Compatibility is critical to safe and effective use of this device. Please contact your local sales or service representative prior to installation to verify equipment compatibility.

Caution:

DISPOSABLES — Disposable devices are intended for single use only. They should not be reused as performance may degrade or contamination could occur.

Caution:

DISPOSAL — At the end of its service life, the product described in this manual, as well as its accessories, must be disposed of in compliance with local, state, or federal guidelines regulating the disposal of such products.

If you have questions concerning the disposal of the product, please contact Bionet or its representative.

Caution:

EQUIPMENT DAMAGE — Devices intended for emergency application must not be exposed to low temperatures during storage and transport to avoid moisture condensation at the application site.

Wait until all moisture has vaporized before using the device.

Portable RF communications equipment (including peripherals such as antenna cables and external antennas) should be used no closer than 30 cm (12 inches) to any part of the Cardio7, including cables specified by the manufacturer.

Caution:

ELECTRIC SHOCK — To reduce the risk of electric shock, do not remove cover or back. Refer servicing to qualified personnel.

Caution:

OPERATOR — Medical technical equipment such as this electrocardiograph system must only be used by persons who have received adequate training in the use of such equipment and who are capable of applying it properly.

Caution:

POWER REQUIREMENTS — Before connecting the device to the power line, check that the voltage and frequency ratings of the power line are the same as those indicated on the unit's label. If this is not the case, do not connect the system to the power line until you adjust the unit to match the power source.

In the USA, if the installation of this equipment will use 240V instead of 120V, the source must be center tapped, 240V single-phase circuit.

This equipment is suitable for connection to public mains as defined in CISPR 11.

Equipment connected to the ECG system and in the patient, environment must be powered from a medically isolated power source or must be a medically isolated device. Equipment powered from a non-isolated source can result in chassis leakage currents exceeding safe levels. Chassis leakage current created by an accessory or device connected to a non-isolated outlet may add to the chassis leakage current of the ECG system.

Caution:









SERVICEABLE PARTS — This equipment contains no user serviceable parts.







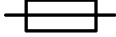



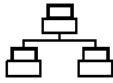

Refer servicing to qualified service personnel.







Caution:

SUPERVISED USE — This equipment is intended for use under the direct supervision of a licensed health care practitioner.

Safety Symbols

Symbols	Contents
	Attention: Consult accompanying documents
	Consult instructions for use: This symbol advises the reader to consult the operating instructions for information needed for the proper use of the device.
	Safety Sign: To signify that the instruction manual must be read. Reading the instruction manual before starting work or before operating equipment.
	General prohibition sign
	Defibrillation –proof type CF APPLIED PART
	Type B APPLIED PART
	AC Power
	Fuse
	Conductor provides a connection between equipment and the potential equalization bus bar of the electrical installation
	ECG Patient Cable Connector

Symbols	Contents	
	USB Connector	
	Spirometry Connector	
	Local Area Network (LAN) Connector	
	Power Off	
	Power On	
	Battery Operation Indicator	
	AC Power Connection Indicator	
	Manufacturer name and address	
	<p>Waste of electrical and electronic equipment must not be disposed as unsorted municipal waste and must be collected separately.</p> <p>Please contact an authorized representative of the manufacturer for information concerning the decommissioning of your equipment.</p>	
	<p>MR Unsafe: Do not use this device in all MR environment</p>	
	No sterilization	 <p>Do not use if package is damaged</p>

Symbols	Contents		
	Single Use Only DO NOT reuse the mouthpiece: it is a single time use only.		Recycling: Dispose of properly in accordance with all state, province and country regulations.
	This way up: For the duration of shipping/delivery, the carton should face upright		Fragile: Handle with care.
	Use no hooks: Absolutely no hand hooks should be attached to pull the parcel.		Keep away from rain.
	Medical Device		

Specifications and functions described in this manual are subject to change without notice for product improvement.

Chapter 1. General Information

1) Product Overview

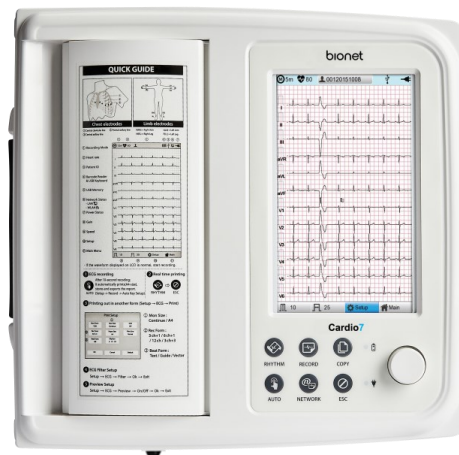

Cardio 7 is a 12-channel ECG (Electrocardiogram) recording equipment that measures and records the patient's ECG. It not only provides parameters necessary for diagnosis, patient's ECG record and automatic diagnosis, but also increases chart management efficiency by providing ECG records and printing reports when patient or user information is entered. At the same time, it can transmit the saved data to a network-connected PC for file management. Its user-oriented design enables ECG examination with a single push of a button. It saves, transfers and prints the data that has been acquired by automatic diagnosis.

It provides the user with the necessary parameters and automatic diagnostics, which are necessary for patient diagnosis, along with the spirometry record. After automatic diagnosis, you can print out a report on A4/letter paper together with the spirometer record to efficiently manage the patient's or user's chart. The stored data is forwarded to a network-connected PC that is in charge of managing digital files. In addition, the battery pack, which can be stored inside as an optional component, ensures high portability and makes it possible to inspect or use the equipment in an emergency.

1-1) Intended Use

The Cardio7 ECG Analysis System is intended to acquire, analyze, display and record ECG information from adult and pediatric populations. The system provides 12-lead ECG and interpretive analysis.

The 12-Lead ECG interpretation algorithm provides analytical information about the patient's heart condition, which must be confirmed by a qualified medical professional along with other relevant clinical information.

Sending and receiving ECG data to and from the Hospital Information System is optional.

The Cardio7 is intended to be used by personnel trained in hospitals or medical professional facilities under the direct supervision of a licensed healthcare practitioner.

In addition, the Cardio7 is intended for prescription use only to perform spirometry diagnostic tests in adults and pediatric patients aged 5 and older in general practice, specialist and hospital settings. The device is intended to be used what measures patient respiratory parameters including FVC, SVC, MVV.

1-2) Indications

The ECG has proven to be among the most useful diagnostic tests in clinical medicine. It is now routine in the evaluation of patients with implanted defibrillators and pacemakers, as well as to detect myocardial injury, ischemia and the presence of prior infarction as well. In addition to its usefulness in ischemic coronary disease, the ECG is of particular use in the diagnosis of disorders of the cardiac rhythm and the evaluation of syncope.

The equipment is commonly used to detect and diagnose pulmonary diseases, such as: Asthma, Cystic fibrosis, Pulmonary fibrosis.

1-3) Contraindications

There are no absolute contraindications to performing an ECG other than the patient's refusal. Some patients may be allergic or, more commonly, sensitive to the adhesive used to attach the electrodes. In this case, use hypoallergenic alternatives available from various manufacturers.

Spirometry is generally considered very safe and rarely causes complications in patients.

It can occasionally cause effects in some individuals, such as dizziness, faintness, shakiness, nausea and fatigue, but these are typically short-lived and resolved shortly after the test. For example, recent surgery to the head, chest, stomach or eye regions may be affected by the pressure and heal incorrectly due to a spirometry test conducted shortly after the procedure.

Additionally, unstable angina, uncontrolled hypertension or a recent myocardial infarction (heart attack) or stroke are also contraindications for spirometry tests.

1-4) Side effect

The ECG is a safe test that does not cause health complications. There are no medical conditions associated with increased risk or adverse side effects of ECG.

1-5) Warnings, Cautions and Adverse Reactions

- a. Modifications to this equipment are not allowed. Any unauthorized changes to the Cardio7

device may compromise product safety and/or data and as such Cardio7 cannot be held responsible and the equipment will no longer be supported.

- b. The Cardio7 is not designed as sterile equipment. Always follow the safety instructions given by the manufacturer of cleaning and disinfectant chemicals.
- c. Cardio7 intended that Disposable Mouthpiece be used for every subject to prevent cross contamination. Disposable mouthpieces provide a significant degree of protection for the subject, equipment, and user from cross-contamination during spirometry.

A mouthpiece is for single use only.

- d. Spirometry is a valuable tool that provides health care providers with important information to consider along with other physical findings, symptoms, and medical history to obtain a diagnosis.

- e. Do not allow the subjects to block the mouthpiece with their tongue or teeth during the test. A 'spitting' action or cough will give false readings.

- f. Do not expose the Cardio7 to liquids.

- g. Do not use Cardio7 in the presence of flammable liquids or gases, dust, sand or other chemicals.

- h. All spirometry standards recommend checking the accuracy of the lung function measuring devices with a 3-L syringe daily to validate that the equipment is measuring accurately.

The Cardio7 should not be outside the accuracy limits.

Accuracy should be checked after cleaning or disassembling the spirometer for any reason, after adjusting calibration or if the flow head or device has been dropped.

- i. Service and repairs should only be carried out by the manufacturer or a service agent approved by Cardio7.

- j. Do not perform maintenance while the equipment is in use by a subject.

- k. Using accessories or cables that are not specified or provided by the manufacturer of Cardio 7 may increase electromagnetic emission or reduce electromagnetic susceptibility, causing them to malfunction.

- l. Non-medical equipment must be kept outside the subject environment i.e. any area in which intentional or unintentional contact between the subject and parts of the system, or some other persons touching part of the system, can occur.

- m. Portable RF communications equipment (including peripherals such as antenna cables and external antennas) should be more than 30cm (12 inches) away from any part of the Cardio7, including cables specified by the manufacturer. Otherwise, degradation of the performance of this equipment could result.

- n. Use of this equipment adjacent to or stacked with other devices should be avoided because it could result in improper operation. If such use is necessary, this equipment and the other equipment should be observed to verify that they are operating normally.

- o. The mouthpiece is in contact with the subject during spirometry sessions with the Cardio7. There are no adverse effects from contact with other parts of the device, including the mouthpiece.
- p. Only use the Cardio7 with the power supply provided. Attempted use with other power sources may cause irreparable damage and invalidate the warranty.

2) Recording ECGs During Defibrillation

This equipment is protected against the effects of cardiac defibrillator discharge to ensure recovery, as required by test standards. The patient signal input of the acquisition module is defibrillation-proof, therefore, it is not necessary to remove the ECG electrodes prior to defibrillation.

When using stainless steel or silver electrodes a defibrillator discharge current may cause the electrodes to retain a residual charge causing a polarization or DC offset voltage.

This electrode polarization will block the acquisition of the ECG signal. To avoid this condition, use non-polarized electrodes, which will not form a DC offset voltage when subjected to a DC current, such as silver/silver-chloride types if there is a situation where there is a likelihood that a defibrillation procedure will be necessary.

If using polarized electrodes, disconnect the lead-wires from the patient before the shock is delivered. Electrode defibrillation recovery is the ability of the electrode to allow the ECG trace to return after defibrillation. It is recommended to use non-polarized disposable electrodes with a Defibrillation Recovery class as specified in AAMI EC12 4.2.2.4. AAMI EC12 requires that the polarization potential of an electrode pair does not exceed 100mV, 5 seconds after a defibrillation discharge.

3) Product Characteristics

- This equipment configures the 12-channel ECG waveforms in various configurations, such as 3 channels + 3 rhythm, 3 channels + 1 rhythm, 6 channels + 1 rhythm, and 12 channels, and prints them on A4 or Letter size paper.
- The rhythm of 1 channel acquired for a certain period of time (1 minute, 3 minutes, 5 minutes, 10 minutes) is printed on A4 or Letter size paper.
- Record and print 12 channel rhythms continuously and simultaneously.
- The heart rate, PR interval, RR interval, QRS interval, QT interval, QTc interval, P-R-T axis, and SV1/RV1/R+S size required for diagnosis are automatically calculated and provided on the report along with the ECG.
- Get diagnostic reports using automatic detection functionality about Neonatal, pediatric,

adult.

- Able to modify filter setting, signal sensitivity, printing speed, channel view settings and rhythm settings, and print on previously recorded EKG signals to aid data analysis.
- Able to attach a battery so that the device can become portable.
- Manage chart effectively by addition of patient and operator data on EKG printout.
- You can store up to 200 patient data, and transfer the stored data to another PC over the network, or save them in a USB memory.
- Various protocols are supported to enable connection with the hospital computer network (EMR, PACS, etc.), and File and Worklist DB functions have been enhanced.
- You can monitor the lung function progress or the result value in real-time basis on the LCD, and the best result is automatically chosen after 3 tests.
- Get diagnostic reports using automatic detection by entering patient information.
- You can transfer the lung function test result data to a network-connected PC for long-term storage, and print it out using a general PC printer.

4) Product Configuration

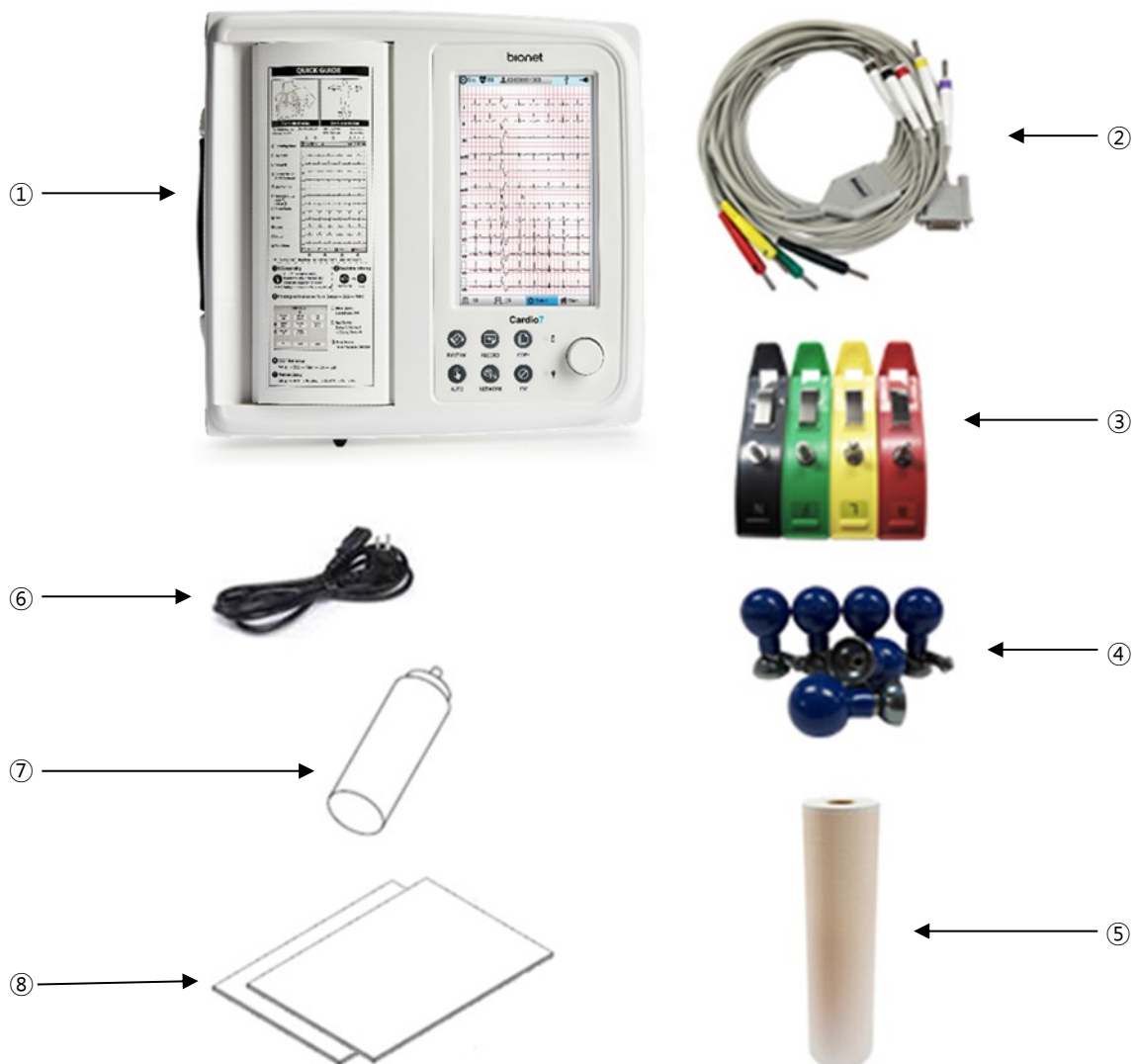

The Cardio7 system consists of the following components. Open the packaging box and check that all components below are included and make sure that the main body or components are not damaged.

4-1) Basic configuration and Accessories



- ① Body (1ea.)
- - Cardio7 Dimension 300(W) x 290(D) x 89.5(H) mm

- ② Patient Cable (1ea.)

No.	Picture	Description
1		<p>Length: 3,550 mm Weight: 0.386 kg Color: Brown color Type: Option</p> <p>Code Number: 152600-019011(EU) 152600-012811(US)</p>
2		<p>Length: 3,350 mm Weight: 0.425 kg Color: White color Type: Standard</p> <p>Code Number: 152600-044400(EU) 152600-044500(US)</p>
3		<p>Length: 3,800 mm Weight: 0.437 kg Color: White color Type: Option</p> <p>Code Number: 152600-044600(EU) 152600-044700(US)</p>

- ③ Limb Electrodes (1 set)
- ④ Chest Electrodes (1 set)
- ⑤ ECG Paper (1ea.)
- ⑥ Power Cable (1ea.) - Length 2,500mm (Max)
- ⑦ ECG Gel (1ea.)
- ⑧ Quick Manual (1ea.) & ECG Diagnostic Guide (1ea.)
- .

4-2) Spirometer (accessory)

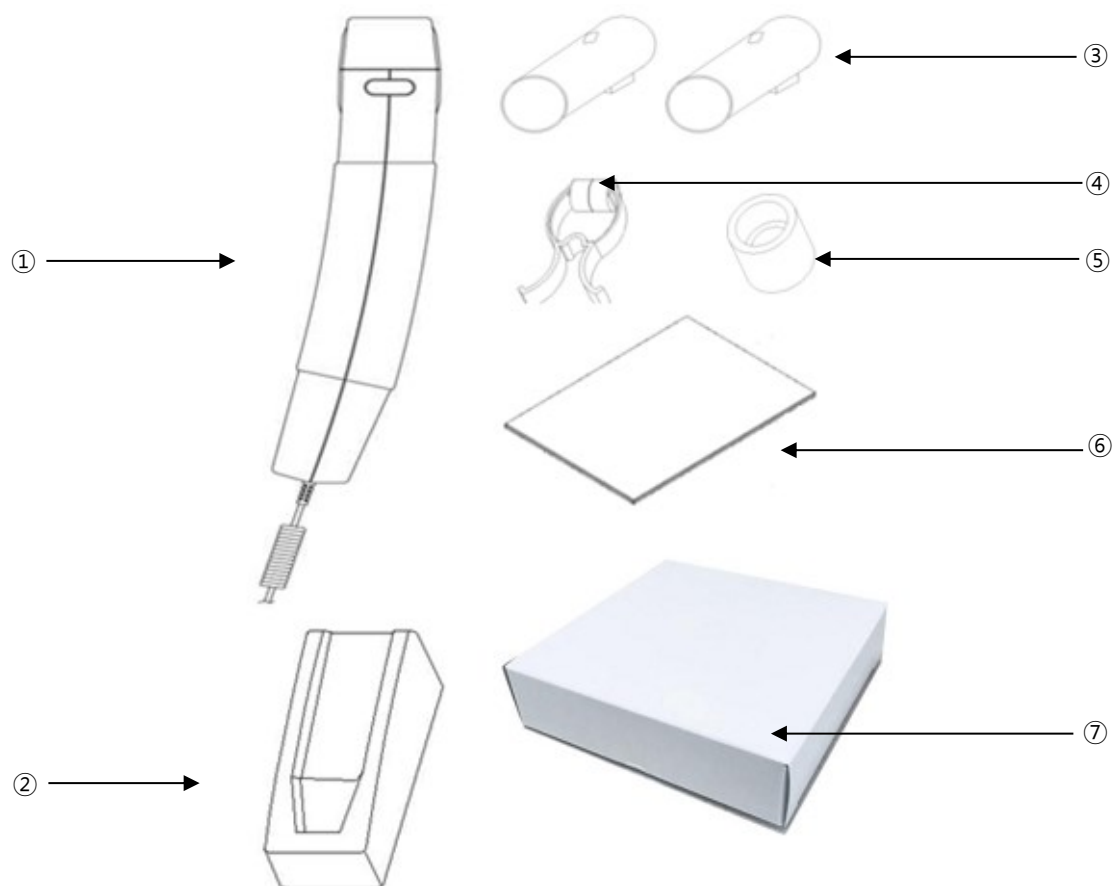

- ① Spiro Handle (1ea.) - Length: 880mm (Normal), 3,480 mm (Max)
- ② Handle Supporter (1ea.)
- ③ Disposable Mouthpiece (2ea.)
- ④ Nose Clip (1ea.)
- ⑤ Mouthpiece Adapter (1ea.)
- ⑥ Spiro Diagnostic Guide (1ea.)
- ⑦ Disposable Mouthpiece 1 box (100ea.)

4-3) Optional Specifications

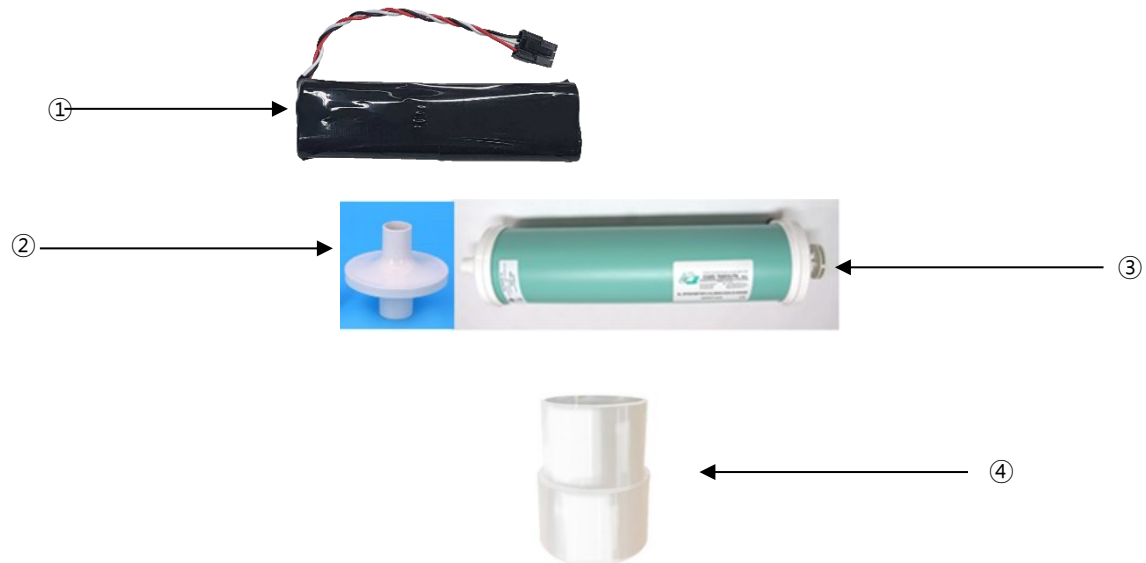

- ① Battery (1ea.) - Replaceable and Rechargeable, Lithium-ion, 10.8 V, 3250mA
- ② PFT Filter (20ea.)
- ③ Calibration Syringe [3L] (1ea.)
- ④ Spiro Connector (1ea.)

Caution

You should use the PFT filter for COVID-19 patients.
If necessary, request additional purchases.

Warning

Bionet is not liable for any problems caused by you not using the battery provided by Bionet.
Make sure to use the genuine battery provided by Bionet.

Caution

Use the mouthpieces that come with the equipment or those which have been certified
for biocompatibility according to international standards.

4-4) Body Configuration

■ Top View

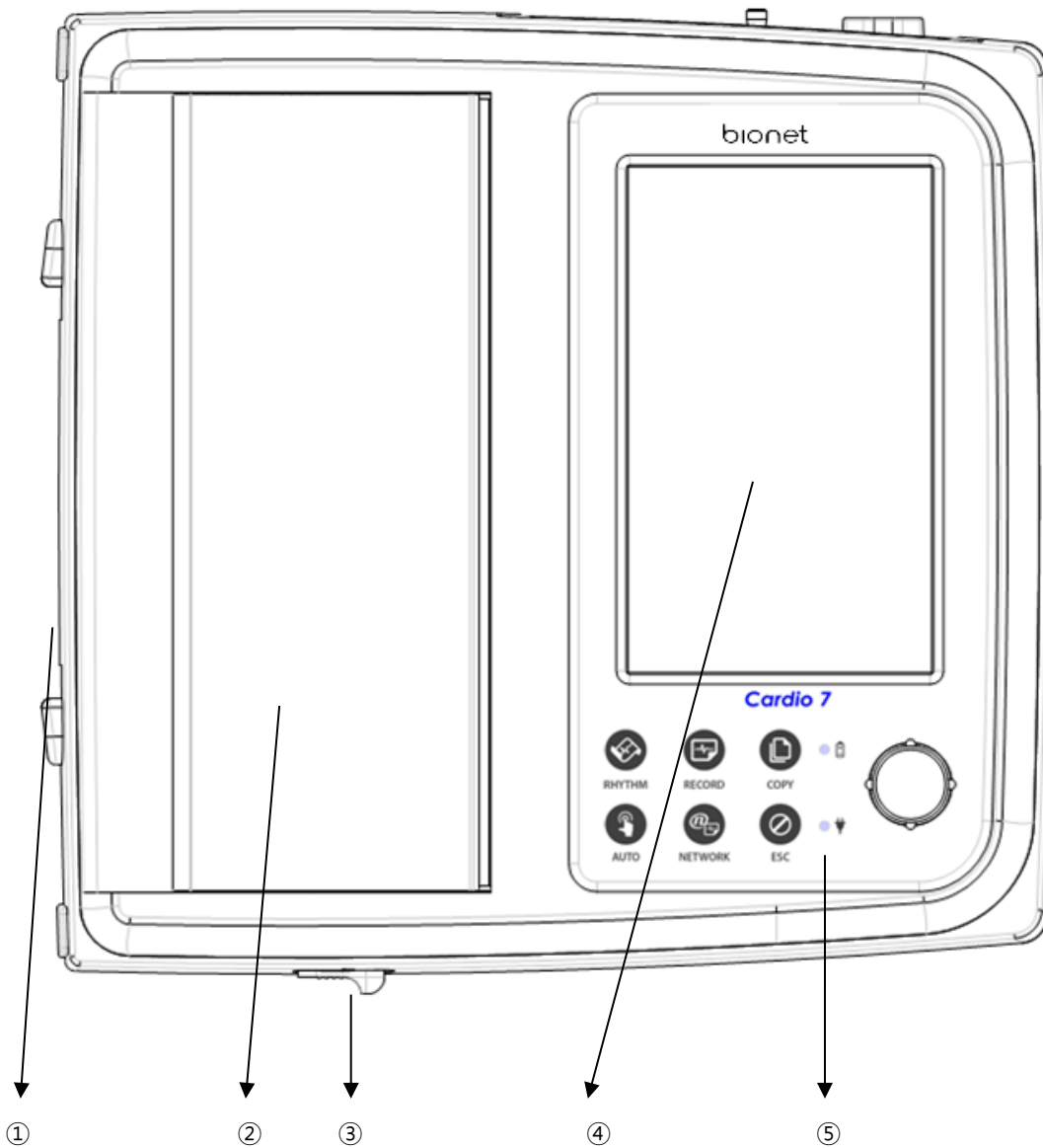

- ① Handle
- ② Printer Cover
- ③ Printer Cover Switch
- ④ LCD
- ⑤ Control Panel

■ Front View

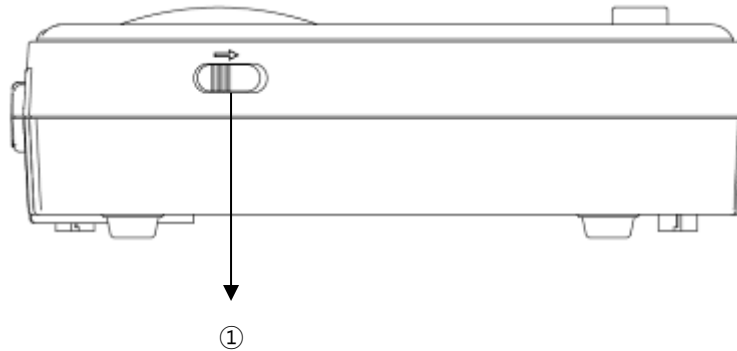

- ① Printer Cover Switch

■ Rear View

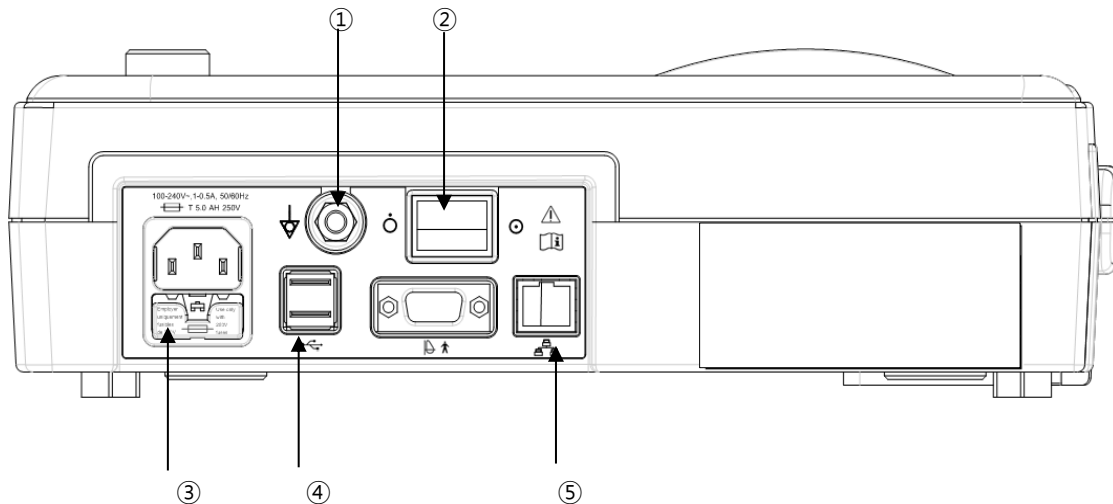

- ① Protective Ground Terminal
 ② Power Switch
 ③ AC Power Terminal: AC power connection (+ Fuse (250V, 3.15AL) x 2)
 ④ USB Port
 ⑤ RJ45 LAN Port

Note

It is recommended to use IEC or KS certified products for USB, computer, laptop. Etc. connected to this equipment.

It is recommended to use certified products for all parts connected to equipment as well as USB

Note

Appliance inlet of separate power supply unit is used as mains disconnecting device.

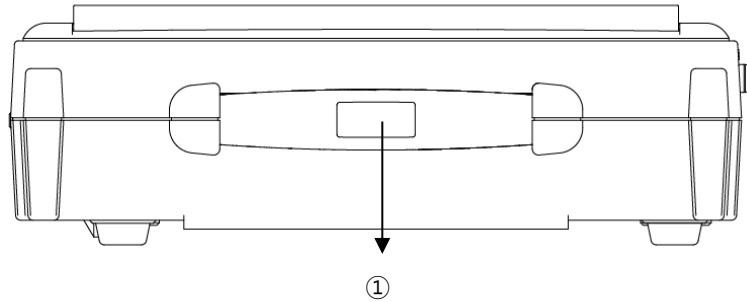
■ Left Side

① Handle

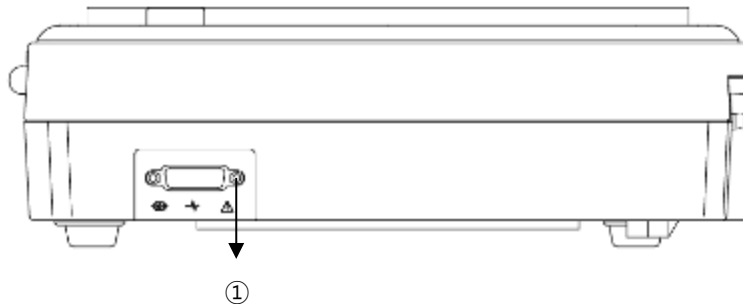
■ Right Side

① Patient Cable Connection Port

Warning

There is a risk of electric shock if the Rest stand of the equipment is damaged or cannot be fixed to the equipment body. Do not use the product and immediately ask the manufacturer and the seller for repair.

Note

Do not open the cover of the equipment; it may cause an electric shock. Repair or disassembly of the equipment can only be performed by those who have product repair qualifications recognized by Bionet.

4-5) Spirometer Handle Configuration

▣ Front View of Spiro Handle

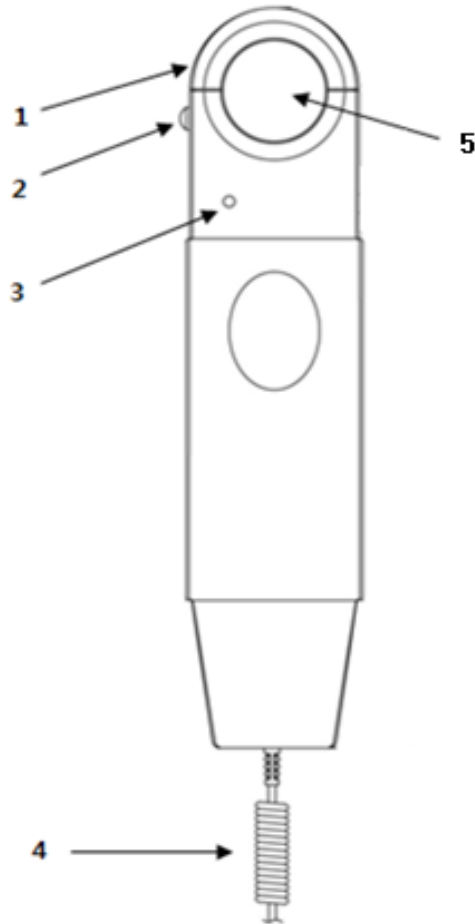

1. Front Cover: Mouthpiece anchoring cover.
2. Front Cover Lock Switch: It locks the mouthpiece anchoring cover.
3. Operation Lamp: It shows the operation status (green)
4. Connection conductor: Conductor connected to USB cable connection hole of serial cable in the back of the main body.
5. Mouthpiece Hole: The mouthpiece is inserted into this hole.

▣ Left Side of Spiro Handle

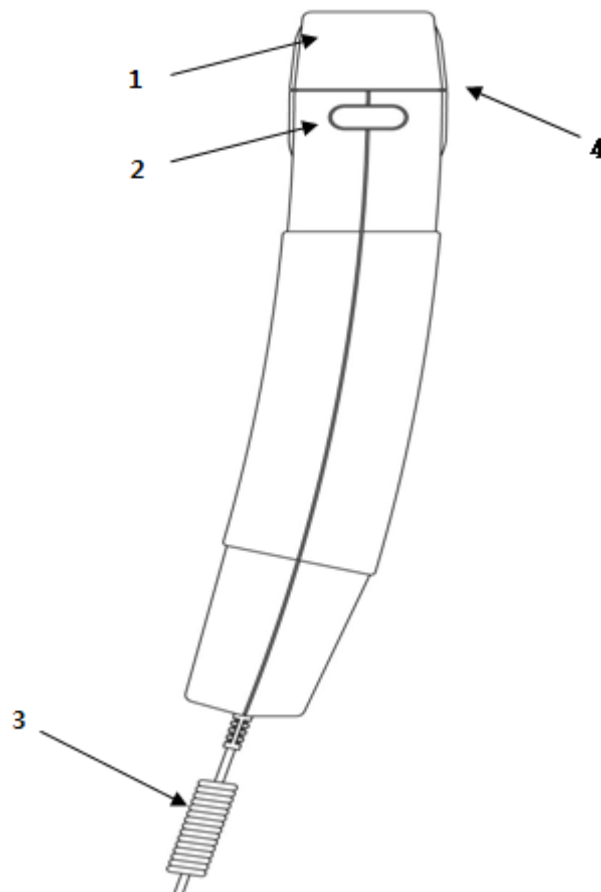

1. Front Cover: Mouthpiece anchoring cover
2. Front Cover Lock Switch: It locks the mouthpiece anchoring cover.
3. Connected Wires: They are connected to the back of the main body.
4. Mouthpiece Hole: The mouthpiece is inserted into this hole.

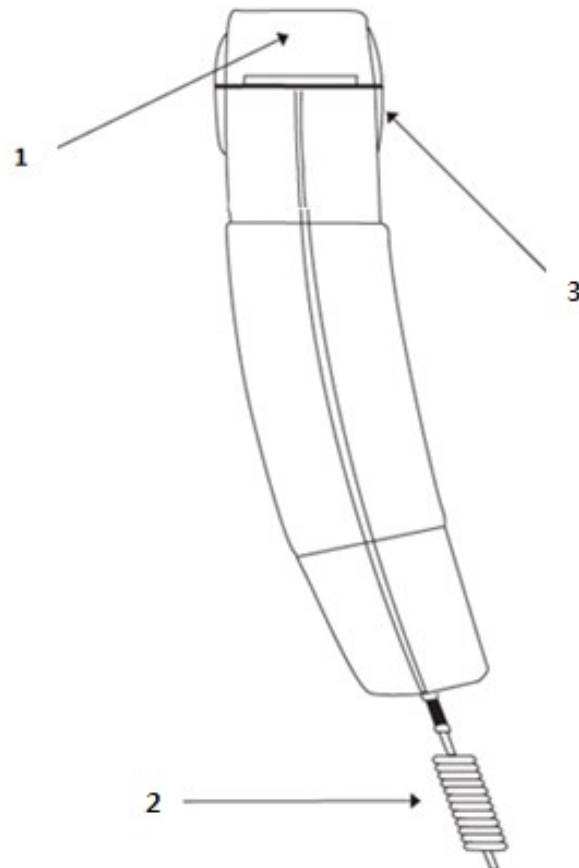
▣ Right Side of Spiro Handle

1. Front Cover: Mouthpiece anchoring cover.
2. Connected Wires: They are connected to the back of the main body.
3. Mouthpiece Hole: Insert the mouthpiece into this hole.

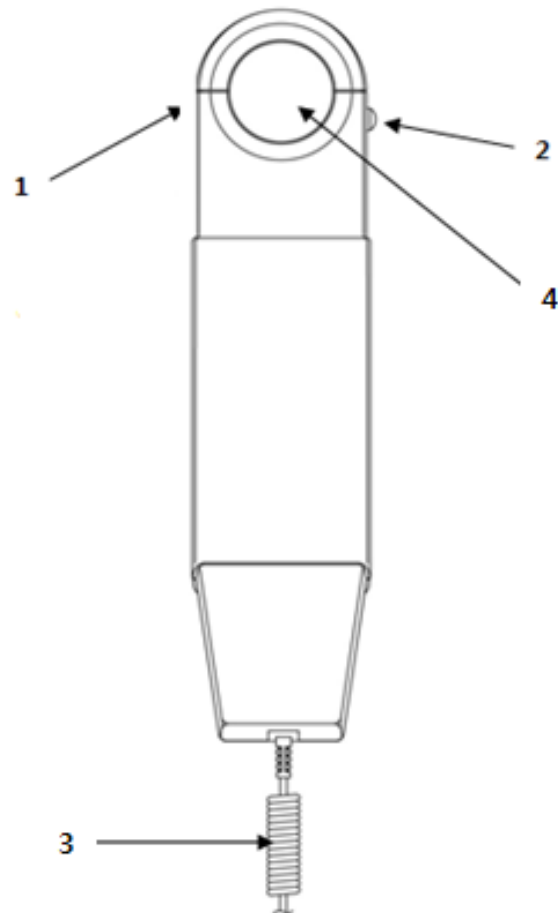
▣ Rear View of Spiro Handle

1. Front Cover: Mouthpiece anchoring cover.
2. Front Cover Lock Switch: It locks the mouthpiece anchoring cover.
3. Connected Wires: They are connected to the back of the main body.
4. Mouthpiece Hole: The mouthpiece is inserted into this hole.

4-6) Front Panel

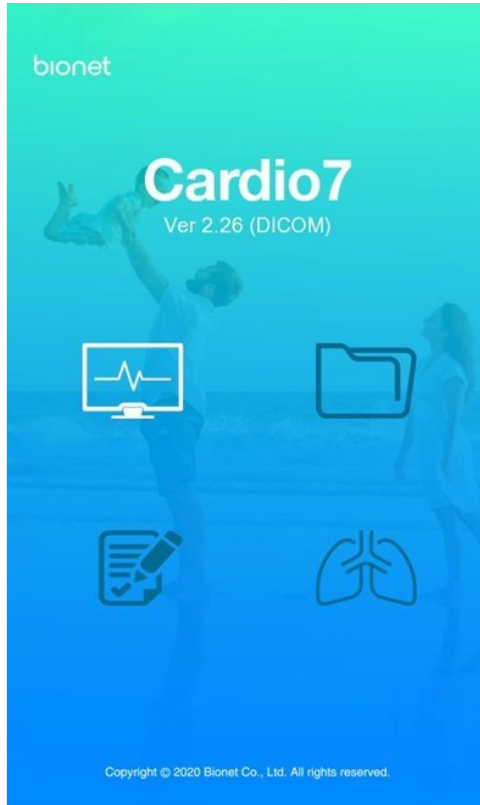

Graphic Display Window

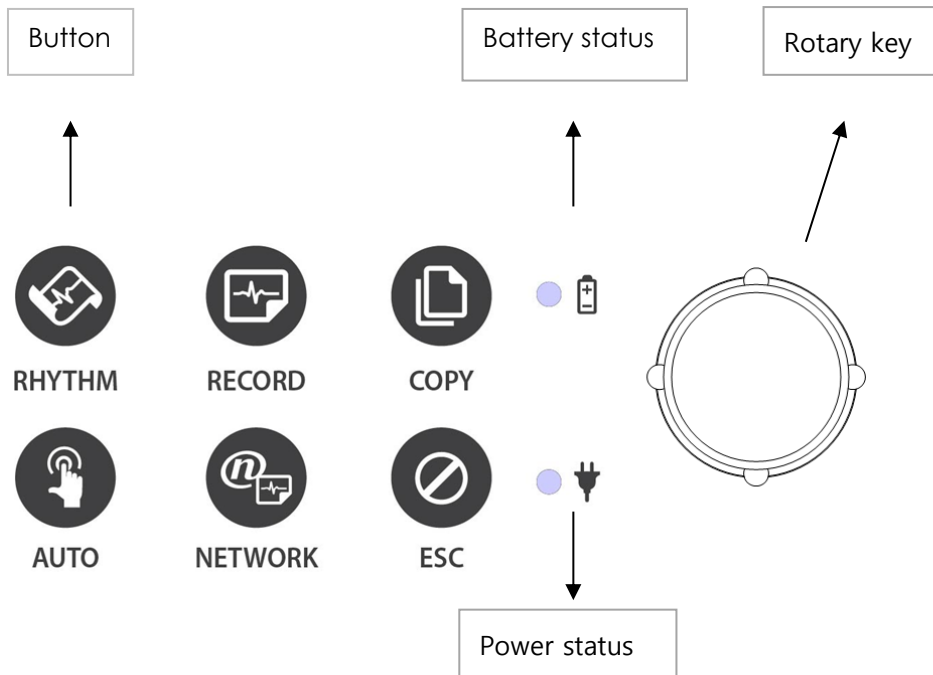

During device boot up, you can see the system software version and the Bionet name.

4-7) ECG Graphic display LCD

The following descriptions explain data on the graphic LCD.

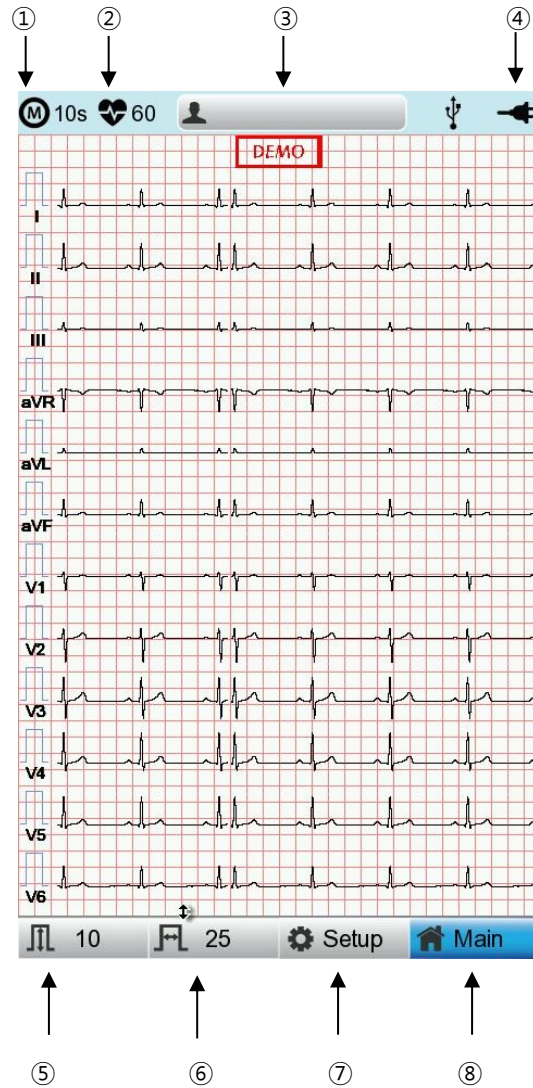

- ① ECG recording mode (10s, 1m, 3m, 5m, 10m)
- ② Heart rate
- ③ Patient ID.
- ④ Battery status or AC power connection status
- ⑤ Current gain: Touch this button to set Gain.
- ⑥ Current print speed: Touch this button to set the print speed.
- ⑦ Setup Menu
- ⑧ Touch this button to move to other menus such as Spiro, File, or Worklist.

4-8) Spiro Graphic display LCD

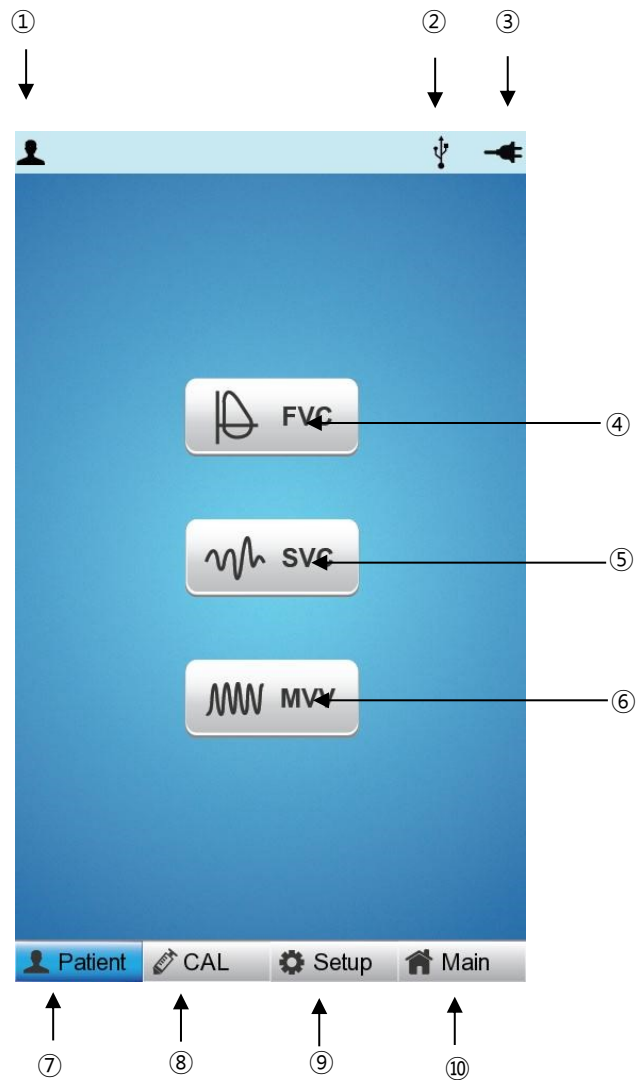

- ① Patient ID
- ② Connection status of the external device
- ③ Battery status or AC power connection status
- ④ Forced Vital Capacity Test Menu
- ⑤ Slow Volume Capacity Test menu
- ⑥ Maximum Voluntary Ventilation Test Menu
- ⑦ Touch this button to enter patient information.
- ⑧ Calibration Menu
- ⑨ Setup Menu
- ⑩ Touch this button to move to other menus such as ECG, File, or Worklist.

4-9) Function Keys

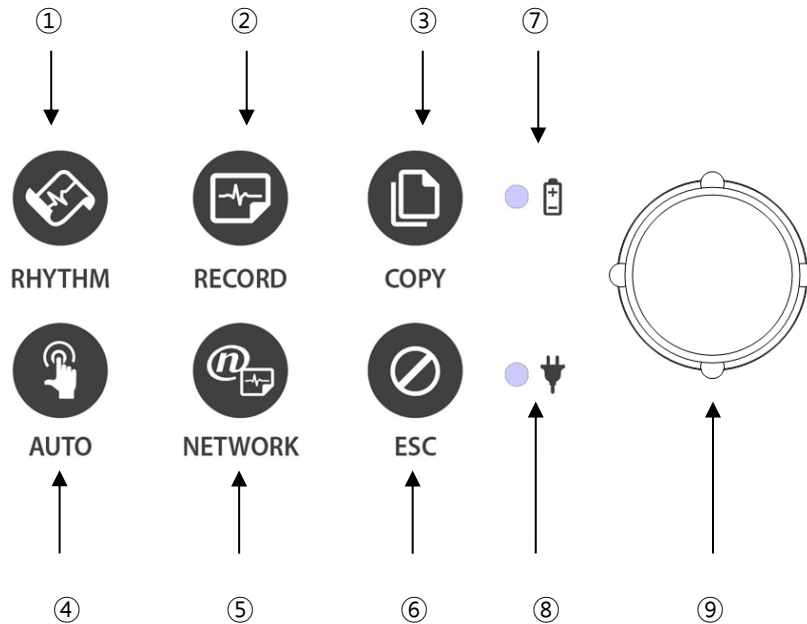

■ Button Description

①		RHYTHM. A real-time ECG waveform is continuously printed or prepared as a report.
②		RECORD. 10sec. and long-term readings (1min., 3min., 5min., 10min.) are printed as an output form after processing.
③		COPY. Previously measured data will be processed and printed in the same way as before or as modified in your settings.
④		AUTO. It operates the product in the most frequently used operation from the ECG diagnosis test to data saving.
⑤		NETWORK. It transfers the test data or saved data to the server PC.

⑥		<p>ESC</p> <p>You can cancel the operation or switch to the previous mode by entering the main menu.</p>
---	--	--

■ **Indicating Lights**

⑦		<p>Battery charge indicator with AC connected: During operation, if the battery is fully charged, the LED lights green, otherwise it turns orange.</p>
⑧		<p>AC Code connection indicator: The LED lights green when the equipment is connected to AC power.</p>

■ **Rotary Key**

⑨		<p>Use when navigating or selecting menu items.</p> <p>(Same functionalities can be achieved by touching menu items on the screen).</p>
---	--	---

4-10) Power

■ **AC Power**

When the equipment is connected to AC power, the Power LED on the front lights green. When a battery is mounted, it is charged in automatic charging mode.

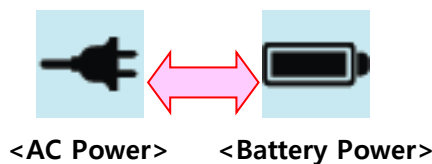

Warning
Be sure to connect this equipment to a power supply with protective grounding.

■ Battery Power

If you turn on the battery-mounted equipment with the AC power supply being cut off, the equipment is powered by the battery and the battery indicator is displayed in the upper right corner of the LCD screen. If the battery power is low, an alarm sounds. Connect AC power quickly to the equipment, otherwise, it automatically turns off after a certain period of time.

- Time required to fully charge the equipment that has been turned off after being completely discharged: Up to 3 hours.
- Continuous use time after full charge:
 - About 6 hours in standby mode without ECG recording
 - You can print up to 200 ECG recordings in 12-channel format at 25mm/s and 10mm/mV settings.
- Battery Type: Lithium-ion battery (10.8V, 3250mAh)

A lithium-ion battery is a rechargeable battery containing lithium-ion cells. Each battery includes an electrical remaining capacity measurement circuit and a safety protection circuit.

Warning

- The battery charge display is accurate only when the battery is functioning normally
- Capacity or operating time of old or defective batteries is significantly compromised.





Note

- Without an AC power supply, it takes up to 15 seconds for the battery-charging display to reflect the actual capacity of the internal battery.

Note

- Bionet recommends replacing the lithium-ion battery after 24 months of use.
- Battery life depends on the frequency of use.
- Continued use by the battery power reduces the battery life and shortens the time of replacement.
- Be sure to recharge the battery before it is completely discharged.

■ Battery Power Status

- : Fully charged.
- : Half charged.
- : Low charged.
- : Almost discharged.

■ Replacing the Battery

Replace the battery with the same type.

- Battery Type: Lithium-ion battery (10.8V, 3250mAh)
- A lithium-ion battery is a rechargeable battery containing lithium-ion cells. Each battery includes an electrical remaining capacity measurement circuit and a safety protection circuit.
- When to replace: When the equipment is connected to a power source, the battery is charged automatically. It cannot be charged separately from the equipment. The battery can be recharged about 300 times or more. Replace it if you cannot use it for longer than 20 minutes even after full charge. In case the battery is damaged or leaks, replace it immediately. Do not use a damaged battery on the equipment.

Warning

- Pay attention to the polarity when replacing the battery.
- Bionet strongly recommends using the battery provided with the equipment.
- Using an unauthorized battery may damage the equipment.

■ The Effect of Lithium-Ion Technology on the Battery

Find out about lithium-ion battery technology here.

The battery is discharged naturally even when not installed in the equipment. Discharging is caused by the current demanded by the lithium-ion battery integrated circuit. Battery is self-discharged due to the nature of lithium-ion cells, and the self-discharge rate doubles for every 10°C (18°F) rise in temperature.

Battery retention loss is greater at higher temperatures. As the battery ages, it may not be fully charged, as a result, the total charge capacity used for saving and using gradually decreases.

■ Conditioning Guidelines

Check battery performance by fully charging and completely discharging it every 6 months.

■ Storage Guidelines

Store the battery between 20°C and 25°C (68°F and 77°F) when it is set aside separately. When the battery is installed in the equipment and connected to AC power, the temperature of the battery increases by 15°C to 20°C (59°F to 68°F) at room temperature, which shortens the life of the battery.

When a battery is installed in the equipment with AC power being connected, normally the equipment does not use the battery power. Battery life may be less than 12 months. Store the battery along with the equipment to prevent being lost and stolen and separate the battery from the equipment when moving the equipment.

■ Recycling the Battery

Replace the battery when it is no longer charged. The battery can be recycled. Remove the old battery from the monitor and follow your local recycling guidelines.

Warning

- Do not incinerate the battery or store it at high temperatures as it may explode, which may cause you serious injury.
- Do not use the battery that has been impacted, disfigured, or submerged; dispose of it.

5) System Installation

5-1) Installation Precautions

Note the following when installing the Cardio7

- Use the equipment within the ambient temperature of 10~40°C and humidity of 30~85%.
- Check the connection of the power cord and handle the patient cable with care.
- Do not plug multiple cords into a single electrical outlet.
- Install the equipment body on a flat surface.
- Connect the ground if noise occurs.
- Do not use the electrical cords that generate connection noise.
- All settings stay saved in the internal memory even when the equipment is turned on and off.
- Handle the equipment with care as it is sensitive to impact.
- Install the equipment in a place with proper ambient temperature and humidity, and away from dust and flammable materials.

5-2) Connection Power

Connect the power cable to the power supply and the power terminal on the back of the Cardio7 to power on.

5-3) Connecting Patient Cable

Connect the Patient Cable to the patient cable connection port on the right side of the equipment.

Connect the limb electrodes to RL (N), LL (F), RA (R), and LA (L) terminals and chest electrodes to V1(C1), V2 (C2), V3 (C3), V4 (C4), V5 (C5) and V6 (C6) terminals of the patient cable.

5-4) Paper Installation

- Push the printer cover release switch to the right to open the printer door of the Cardio7. Install EKG paper with the side to be recorded appearing on top. Close the cover to finish the paper installation process.

Warning

Use only the ECG recording paper provided by Bionet for ECG recording. Otherwise, the poor printing quality may affect the doctor's diagnosis. Bionet is not liable for any problems caused by you not using the ECG recording paper provided by Bionet.

Warning

Modifications to this equipment are not allowed.
Do not disassemble or modify this equipment without the manufacturer's approval.
Repair or disassembly of the equipment can only be performed by those who have product repair qualifications recognized by Bionet.

Caution

Do not use the equipment together with other electronic devices.

5-5) Connecting the Network

As only the service technicians can connect this equipment to the network, consult with the IT staff in the hospital in advance.

Follow IEC 80001-1, which is the Risk management of IT networks to which medical devices are connected.

5-6) LAN Network

Generally, the LAN networks are configured based on a star topology. You can group Individual devices together via layer-n-switch. Other data traffic is separated by other VLAN networks. Configure the network according to this manual and your network specifications.

LAN connection specifications are described in the following standards.

- Wired Network: IEEE 802.3
- Wireless Network: IEEE 802.11 (a, b, g, n)

The data transmitted on the wireless network can be secured by one of the following methods:

- WEP
- WPA-PSK
- WPA2-PSK

If the equipment is used as a layer-2-switch or layer-3-switch, the port settings must be configured on the network switch. Configure the network of Bionet equipment to be compatible with the

specifications of your operating organization.

The equipment exchanges data with other medical devices via a LAN network. The network must support the following protocols:

- TCP/IP
- BROADCAST

5-7) VLAN Network

If data is exchanged within a single network, you must establish an independent VLAN network for clinical information systems, such as a network dedicated to medical devices in hospitals. Also, you should build a network system that detects and defends against denial-of-service attacks by establishing a system dedicated to DDos protection.

5-8) When using an inappropriate network

If your network does not meet the requirements, the following may occur:

- Without a firewall and antivirus software:
 - Data is not protected.
 - Data is transferred incomplete or not transferred at all.
 - Data may be sent to the wrong server.
 - Data may be blocked, forged or damaged.
- Without an independent network configuration or dedicated system for DDos defense:
 - You may be subject to denial of service attacks (DDos). In this case, the equipment may become slow or may not work properly. In rare cases, you may experience the delayed or repeated booting.

5-9) Network Security

- Ensure that appropriate security measures are taken to protect data transmission.
- Security of the network is the sole responsibility of the network operator.
- Bionet recommends the following to guarantee the security of the network.
 - Define access authorization for the configuration of the host system so that no unauthorized alterations of the system can occur.
 - Install an up-to-date antivirus/firewall program so that any malware cannot jeopardize the system.
 - Update the security and software regularly.

Apply the "Risk Management of IT Networks" according to IEC 80001-1.

6) System Start

When you turn on the equipment, the product name is displayed and the initial menu appears as shown in the picture below.



You can move to the main page of the chosen menu by touching the menu on the screen or rotating the key on the control panel.

The picture below shows the ECG main screen that is loaded when you choose the ECG menu.

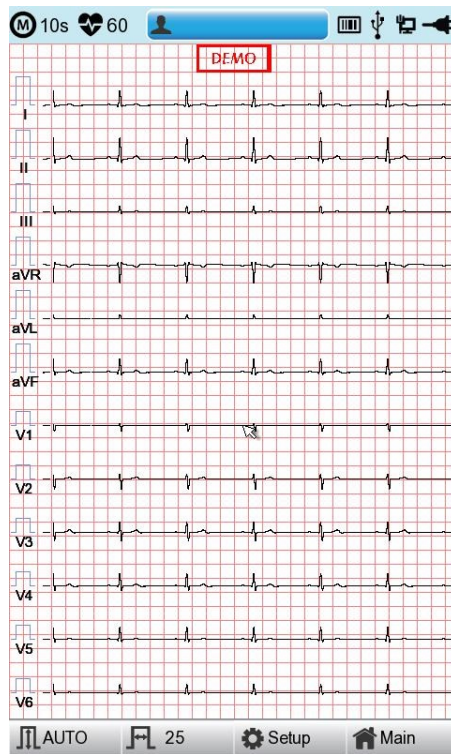

The following is a description of the ECG initial screen menu.

Menu	Description
	ECG Recording mode (10s, 1m, 3m, 5m, 10m)
	Heart rate
	Patient information
	Barcode reader or USB Keyboard connection mark
	Replaced by the icon when a network error occurs during transfer to the PACS server. You can move to the Study Queue screen by touching the icon.
	USB Memory connection status
	Network status mark (wired: , wireless :).
	Move to the Network Setup screen by touching the icon. : The error icon will appear in the event of an IP conflict





	Power status (AC power or battery)
	To set up the size of the ECG waveform
	To set up the speed for printing out the ECG waveform
	Touch this button to set the System.
	Go to the main screen: Spiro, File, or Worklist.
	Go to the main screen: Spiro, File, or Worklist.

Touch [File] to bring up the ECG data management screen as follows.

No	ID	Name	Age	Date	Study
1	uuj	ryhj	0	20150708	ECG
2	1234		0		ECG
3	234		0		ECG
4	cdee		0	20150512	MVV
5	ddrrg	rdvgy	0	20150512	FVC
6	ed		0	20150512	FVC
7	gjijn		0	20150512	ECG
8	ujj		3	20150512	FVC
9	wrtu		0	20150512	FVC
10	1234		0		ECG
11	234		0		ECG
12	cdee		0	20150512	MVV
13	ddrrg	rdvgy	0	20150512	FVC
14	ed		0	20150512	FVC
15	gjijn		0	20150512	ECG
16	ujj		3	20150512	FVC
17	wrtu		0	20150512	FVC
18	1234		0		ECG
19	234		0		ECG
20	cdee		0	20150512	MVV
21	ddrrg	rdvgy	0	20150512	FVC
22	ed		0	20150512	FVC
23	gjijn		0	20150512	ECG
24	ujj		3	20150512	FVC

The following is a description of the File menu.

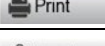
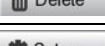

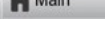
Menu	Description
	File number on the current location/entire file number
	Go to the previous page.

	Go to the next page.
	Patient information
	Search data by entering search criteria.
	To print out the chosen data
	Delete the selected files. It appears when server is connected.
	Touch this button to set the System.
	Go to the main screen: ECG, Spiro, or Worklist.

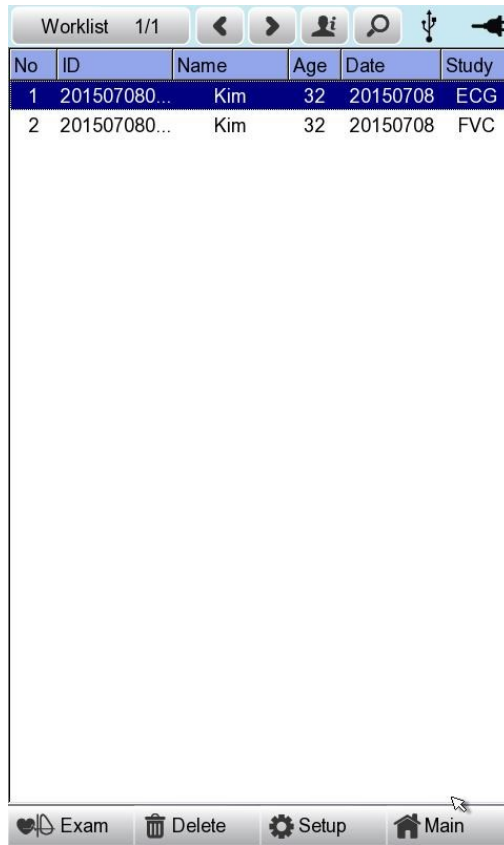
Touch [Worklist] to bring up the exam-requested patient management screen as follows.



The following is a description of the Worklist menu.

Menu	Description
Worklist 1/1	Order number in the current location/entire order number
	Go to the previous page.
	Go to the next page.
	Patient information

	Search data by entering search criteria.
	Go to the exam screen.
/	Delete the selected files. It appears when server is connected.
	Touch this button to set the System.
	Go to the main screen: ECG, Spiro, or File.

Touch (Study Queue icon) to bring up the Study Queue data management screen as follows. Study Queue manages data that has failed to be sent to the server.

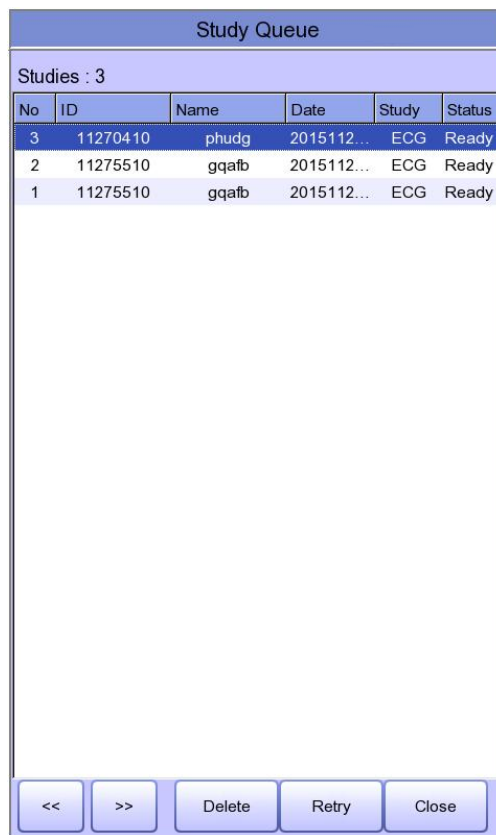

The following is a description of the Study Queue management menu.

Menu	Description
	Number of Study file marks
	Go to the next page
	Go to the previous page.
	Delete the selected data.
	Transfer the selected data.

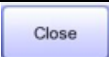
	Close the window.
---	-------------------

Note	
-	 The icon appears on the right top corner only if there is an error while sending files.

Part I. Recording ECG

Chapter 2. ECG Recording Preparation

1) Attaching the Electrodes

To record a standard 12-lead ECG, attach electrodes to the patient's body as shown below.

● Electrode Placement

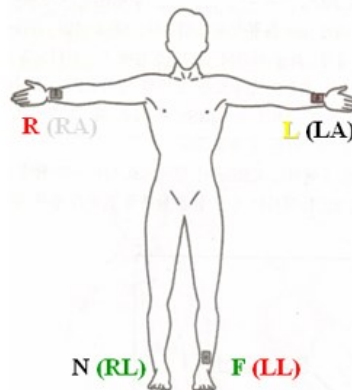

Limb Leads

- R(RA) : Right Arm, L(LA) : Left Arm
- N(RL) : Right Leg, F(LL) : Left Leg

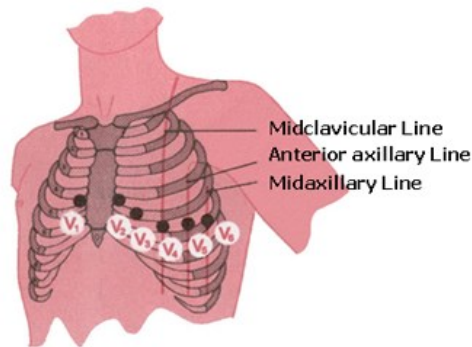

Chest Leads

- V1 : 4th intercostal space at the right sternal border
- V2 : 4th intercostal space at the left sternal border
- V3 : Equidistant between V2 and V4
- V4 : At the midclavicular line in the 5th intercostal space
- V5 : At the anterior axillary line in the same horizontal plane as V4
- V6 : At the midaxillary line in the same horizontal plane as V4

The positions to attach limb electrodes are as follows:

- RL (N): Right leg
- LL (F): Left leg
- RA (R): Right arm
- LA (L): Left arm

The positions to attach the chest electrodes are as follows:

- V1 (C1): Boundary of fourth intercostal on right side of chest
- V2 (C2): Boundary of fourth intercostal on the left side of chest
- V3 (C3): Mid-location between V2 (C2) and V4 (C4)
- V4 (C4): Mid-location of the front side of fifth intercostal collarbone
- V5 (C5): Front armpit on the horizontal line with V4 (C4)
- V6 (C6): Mid-armpit on the horizontal line with V4 (C4), V5 (C5)

2) Connecting Electrodes

2-1) Checklist

- Before the exam, check the condition of the equipment and patient, and whether each electrode is well attached.
- Make sure that there are no mechanical hazards.
- Check the status of cables and accessories connected externally.
- Check the status all the measuring devices for the patients.

2-2) Connecting Patient Cable

Connect the patient cable to the port on the right side of body and connect limb electrodes to the terminals of RL (N), LL (F), RA (R), and LA (L) of patient cable connected in the Cardio7 and chest electrodes to the terminals V1 (C1), V2 (C2), V3 (C3), V4 (C4), V5 (C5) and V6 (C6).

2-3) How to Attach the Electrodes

Have the patient lie down on the bed and release the tension in the skin area where the electrodes will be attached. Clean the area with disinfected alcohol or water before attaching electrodes. In case the patient is hairy on the attaching spots, shave them. If the attachment body part is curved and it is difficult to attach the electrodes, attach them to the positions that are as similar as possible without a curve.

If the noise is severe even if you have used alcohol or water, apply the ECG gel to the attaching spots before attaching the electrodes.

Be sure to wipe off the used ECG Gel, because if it gets dried and hardened, it can generate noise in the ECG signal.

Warning

Be sure to use only the electrodes and patient cable provided by Bionet. Bionet is not liable for any problems caused by your using unauthorized parts.

2-4) What to Do with Poor Lead Connection

Turn on the equipment, enter the ECG mode, and check the connection of all leads and the noise level of the waveform. A message appears in case of a lead fault.

Lead Fault! All Leads.

Note

- Lead fault message appears only when Lead fault is set to On in ECG General Setup. Otherwise, it will not appear.
- Fault leads and saturation leads in red in yellow.
Proceed with the ECG exam only when the leads are connected properly.

Take the following measures when the lead connection is poor.







- When the electrodes come off from the skin: Reattach the electrodes following the electrode attachment method.
- When conductivity between the skin and the electrodes is weak: Apply the ECG gel to the electrode-attaching spots and reattach the electrodes.

If the ECG signal is not accurately acquired even after you try all the solutions above, the patient cable may be non-conforming. Contact Bionet's service center.

3) Recording ECG

- Enter accurate patient information.
- Connect the ECG cable to the patient in compliance with the ECG measurement preparations.
- Check or change settings such as Filter, Gain, Output Speed, Channel Configuration, Rhythm, etc.
- Refer to What to Do with Poor Lead Connection if the waveform drawn in the LCD screen is abnormal or there is too much noise.
- If the waveform displayed on the LCD screen is normal, press the [RECORD] key to record the ECG.
- Press the [COPY] key either to print it out as modified in your settings.
- Press the [RHYTHM] key to print out the ECG signal waveform in real-time.
- Press the [ESC] key to stop printing or saving the ECG results.

The following is a description of the ECG recording menu.

	<p>RHYTHM.</p> <p>A real-time ECG waveform is continuously printed or prepared as a report.</p>
	<p>RECORD.</p> <p>10 second long term readings (1 min, 3 min, 5 min, 10 min) are acquired and printed in output format.</p>
	<p>COPY.</p> <p>Previously saved data is printed unabridged or as modified in your settings.</p>
	<p>AUTO.</p> <p>It operates the product in the most frequently used operation from the ECG diagnosis test to data saving.</p>
	<p>NETWORK.</p> <p>It transfers the test data or saved data to the server PC.</p>
	<p>ESC.</p> <p>You can cancel the operation or switch to the previous mode by entering the main menu.</p>

4) Basic Setup

4-1) General Information

When you turn on the equipment, top and bottom menu bars and graphic window appear on the LCD screen.

Top menu bar: Test Mode, Heart Rate, Patient Information, External Device Connection Status, Network Status, Power Status,

Bottom menu bar: Output Gain, Speed, and Setup.

Touch the menu buttons on the LCD screen to change settings.

They can be modified in two ways.

These configuration values can be changed using either a rotary key or touch screen. With the rotary key, the desired menu and changed configuration values can be set easily.

Same functionality can also be achieved with the touch screen by pressing and changing the desired information on the LCD.

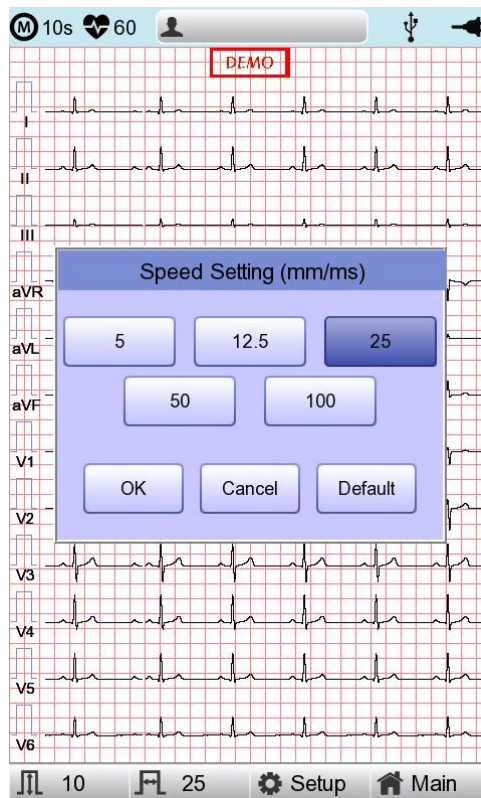

4-2) Changing the Configuration Value with The Rotary Key

In this case, please follow these steps: enter Menu Mode, navigate and select Menu and then change values.

- Entering Menu Mode

The rotary key is supposed to rotate clockwise. When the user selects the ECG Main, the initial focus will point to the 'patient' item.

The following is the page you will see when you rotate the key clockwise and click it to enter the speed menu.

- Menu Navigation

Operate by rotating the rotary key. Menu movement will occur in the same direction as the direction of the key's rotation.

- Menu Selection

Initiate by pressing the rotary key. Menu box for setting of the selected menu will be displayed.

- Modifying setting values

Move to desired setting, then modify & select values in the same manner as menu movement shown above. When you select either 5mm/sec, 12.5mm/sec, 25mm/sec, 50mm/sec or

100mm/sec at the 'Speed Setting' POP-UP, the POP-UP window will disappear.

4-3) Using the touch screen to modify the information

When using the touch screen, only two procedures, menu selecting and information modification, are required.

- Selecting Menu

Touch the menu buttons on the screen.

- Setting the Value

Select a menu and touch [OK].

4-4) Patient Information Input

Enter the patient's personal information before starting the ECG test.

Note

- The patient's surname is available after changing the file version to 1.1 in the BMS Server settings.
- Patient information will be initialized if the language preference is changed in the system setup.

Patient ID

Enter a unique number used in the hospital to classify patient medical data. Touch the input field of ID to display the keypad window consisting of alphabets and numbers. Use the keypad window to enter patient ID.

When the user wants to set the data after inputting, the user can press OK button on the keyboard and if the user wants to cancel the setting, pressing ESC button will do it and the keypad window will disappear.



Note

- Do not use ", <, >, ?, /, *, |, ;, ₩, etc (these invalid characters are set to be inactive) characters for ID.
- Use only plain alphabets and numbers for ID. If you enter an ID in Latin extended characters or Russian, an error may occur when you transfer files with the IDs to a PC or USB memory.

Patient Name

Enter the patient name in the same way as entering the ID.

Age

Enter an age and select the year of birth for >1 year old; enter age in the form of week or day for 1 < year old. Automatic diagnosis is available from postnatal day 1 for pediatrics.

Note
<ul style="list-style-type: none">- Pediatric diagnosis of the ECG is available from the first day of birth.- If age is not entered, an adult diagnosis is provided.

Gender

Touch the input field of Gender to select Male or Female.

Height

Enter the patient height in the same way as entering the age.

If the Height Unit is set to inches in System General Setup, enter the height in ft and inches.

Weight

Enter the patient weight in the same way as entering the age.

Race

Enter the race of the patient. There are 3 registered races: Asian, White, and Black.

Touch the input field of Race to select the race type.

Other Information

Enter Smoke, Department, Room No., Study Description, Accession No., and Referring Physician in the same way as entering ID.

Touch [OK] to save the settings or [Cancel] to cancel the settings. Touch [New] to initialize all the patient information you have entered.

4-5) Using a Barcode Reader



Place the cursor on each item in the patient information screen and scan the barcode. Information is entered automatically.

When you scan the barcode in the ECG main screen, the patient ID is entered automatically.

Basically, you can use any kind of barcode reader.

However, since the default setting of the entry method of each product may be different, check the method supported by Bionet before using them.

- Entry methods supported by Bionet products: International standard and USB
- The products that have been tested by connecting to Bionet equipment are listed below.

No.	Manufacturer	Product name	Product image
1	Symbol	LS-2208	
2	ZEBEX	Z-3110	
3	Honeywell	MS5145	

Note

Each barcode reader has a product-specific initialization code.
Be sure to read the user manual of the product and check the entry method before initializing it.

4-6) Sensitivity Setup

Adjust the Gain if the size of the output signal is too large to overlap neighboring channels, or it is too small to decipher.

Settings: - Set the limb leads (I, II, III, aVR, aVL, aVF) and chest leads (V1, V2, V3, V4, V5, V6) to the same value: 2.5mm/mV, 5mm/mV, 10mm/mV, and 20mm/mV.

- Set the limb leads and chest leads to different values: limb leads 10mm/mV / chest leads 5mm/Mv.

10mm/mV means that a signal of 1mV is drawn at a size of 10mm on screen.

The left side of the graph display will show the channel name and a bar graph, so users can notice recently changed values easily. However, for 20mm/mV, the size of signal is set to be shown for 6 signals only to avoid overlapping signal size displays.

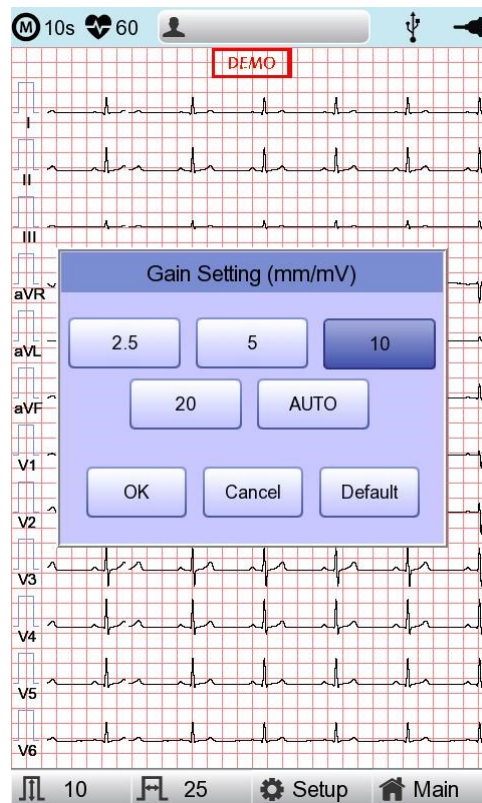

Note

When you set the recording mode to 3min, 5min, 10min the printing size is fixed at 5.0mm/mV.

4-7) Printing speed Setup

Adjust the width of the output signal for screen output and printout. The available values are 5mm/sec, 12.5 mm/sec, 25mm/sec, 50mm/sec, and 100mm/sec. 25mm/sec means that the ECG signal for 1 second is recorded with a length of 25mm.

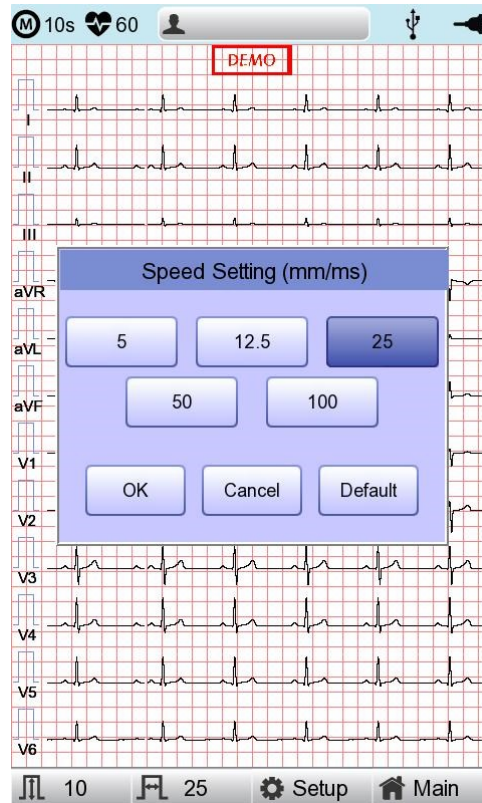

Note

- If you set the Rhythm Size of monitoring to Report, the signal is always printed at 25mm/sec regardless of the Output Speed setting.
- When you set the recording mode to 1min, the signal is always printed at 25mm/sec.
- When you set the recording mode to 3min, 5min, 10min the signal is always printed at 12.5mm/sec.

5) Disclosure

Touch the graph window of the ECG main screen for 3 seconds to switch to Disclosure screen. Disclosure is a function that stores ECG data in the equipment memory and shows it when executed.

In the Disclosure screen: The pre-stored 5 minutes of ECG data are displayed in 1CH. The interval section of the pre-set mode (10 seconds) is marked with a square, allowing you to print diagnosis for the selected area or transmit data of the area.

Touch the graph window and select the screen output section: your touch point becomes the center of the square-marked area. Select the screen output section and press the [Record], [Auto] and [Net] key.

On the control panel to print diagnosis or save and transmit the data.

Refer to the following description for Disclosure screen.

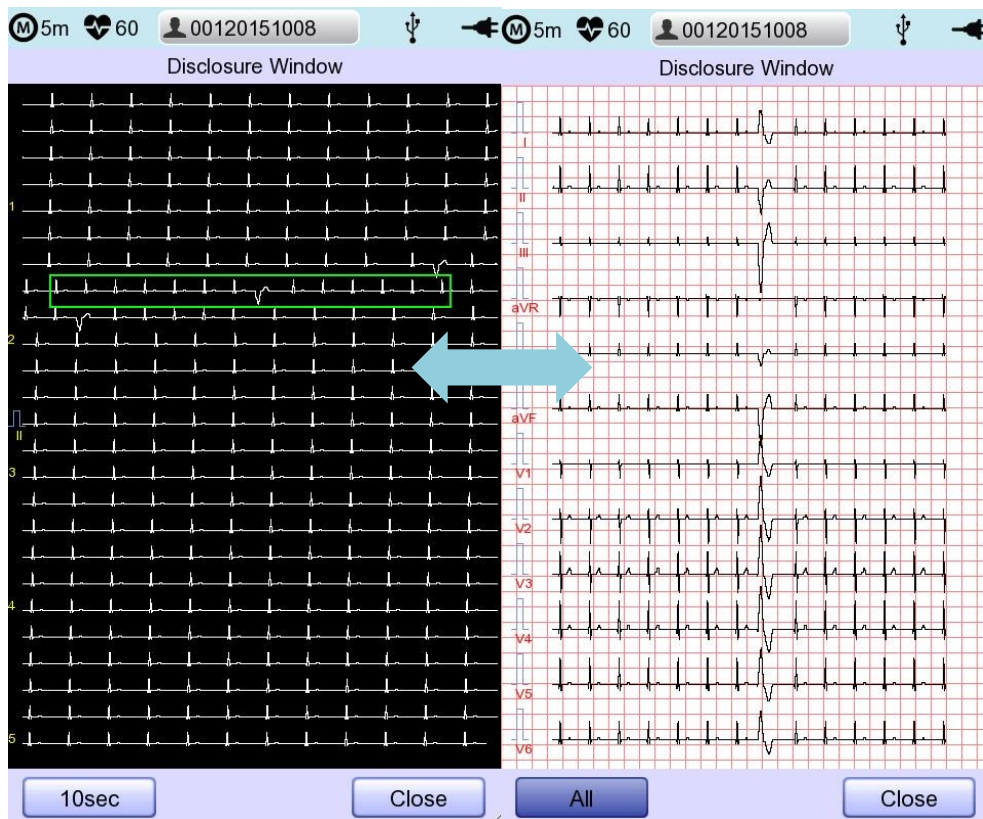

6) LCD Monitor display

The current ECG signal is drawn on the LCD screen in real-time.

Start the test after confirming that the signal is correctly transmitted from all leads.

Note
The detection range of heart rate is 30-300 bpm with \pm 3bpm of error range.

7) Real-time Printing (RHYTHM Key)

Press the [RHYTHM] key on the control panel to print the ECG signal in real-time.

You can set the output speed of Rhythm among 5mm/sec, 12.5mm/sec, 25mm/sec, 50mm/sec and 100mm/sec. For Gain, you can set among 2.5mm/mV, 5mm/mV, 10mm/mV, 20mm/mV, and auto.

Set the print form to 3CH, 6CH, or 12CH.

When you press the [RHYTHM] key on the control panel, the message "System" is displayed on the screen and the printing starts according to the set speed.

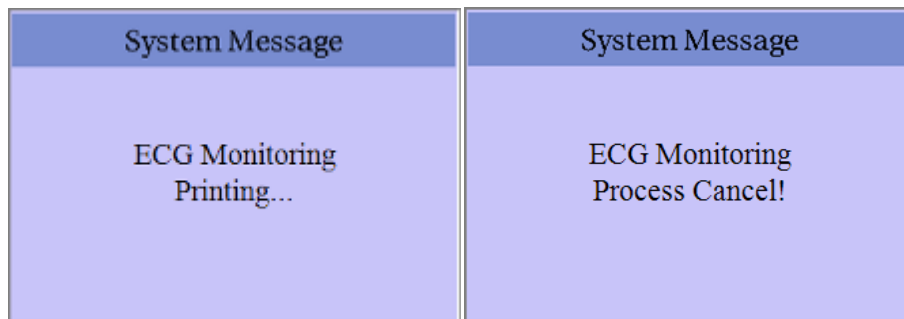

- 3CH printing: 3 channels are printed simultaneously. (I ~ III / aVR ~ aVF / V1 ~ V3 / V4 ~ V6)
To change the channel, press the [RHYTHM] key on the control panel again.
- 6CH printing: 6 channels are printed simultaneously. (I ~ aVF / V1 ~ V6) To change the channel, press the [RHYTHM] key on the control panel again.
- 12CH printing: 12 channels are printed simultaneously. (I ~ V6)

Press the [ESC] key on the control panel to stop the printing.

Note
Even if ECG output speed is set as 100 mm/sec, it is not supported when outputting monitoring.

Note

Do not attempt to attach or detach a USB device while the printer is working as it may cause the printer module to rattle.

8) Record Mode Printing

Press the [RECORD] key to diagnose the ECG acquired during the set duration, and print the result.

8-1) 10 seconds ECG recording

Press the [RECORD] key on the control panel to acquire ECG for 10 seconds. A timer is shown on the top.

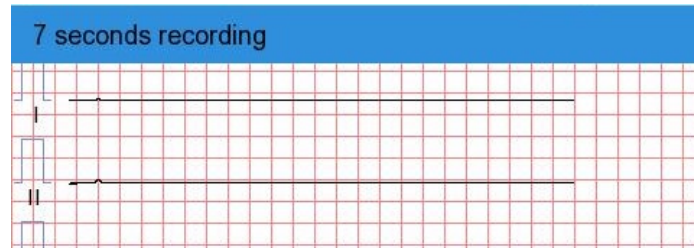

Automatic diagnosis is made based on the 10-second resting ECG, and the preview screen appears as follows.

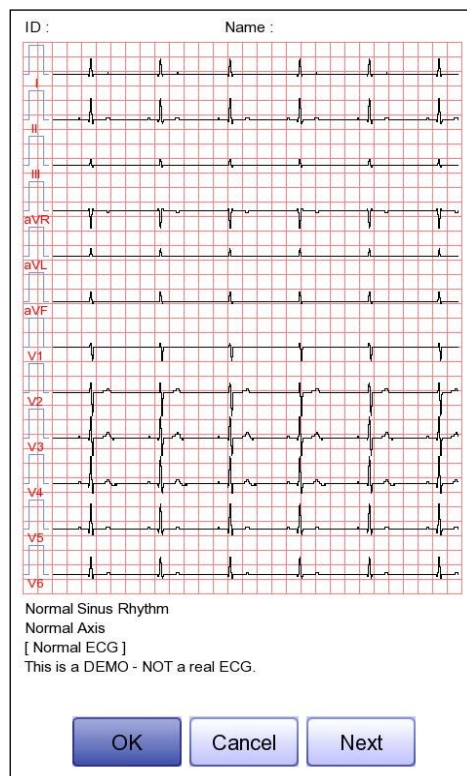

Touch [OK] if the data is reliable.

Note
Set Preview settings in Setup → ECG → Preview on.

9) Printing Form

Record Form

Set the diagnosis print format.

Print Format	Description
3CH+3	10-second resting ECG recording: I, II, and III in the first 2.5 seconds; aVR, aVL, and aVF in the next 2.5 second; V1, V2, and V3 in the next 2.5 seconds; and V4, V5, and V6 in the next 2.5 seconds. The 3-lead rhythm is recorded at the bottom for 10 seconds.
3CH+1	10-second resting ECG recording: I, II, and III in the first 2.5 seconds; aVR, aVL, and aVF in the next 2.5 second; V1, V2, and V3 in the next 2.5 seconds; and V4, V5, and V6 in the next 2.5 seconds. The 1 lead-rhythm is recorded at the bottom for 10 seconds.
6CH+1	10-second resting ECG recording: I, II, III, aVR, aVL, and aVF in the first 5 seconds; V1, V2, V3, V4, V5, and V6 in the next 5 seconds. The 1 lead-rhythm is recorded at the bottom for 10 seconds.
12CH	The 12-lead rhythm is recorded simultaneously for 10 seconds in the order of I, II, III, aVR, aVL, aVF, V1, V2, V3, V4, V5, and V6.
6CH+1 (ST)	8-second ECG recording: I, II, III, aVR, aVL, and aVF in the first 4 seconds; V1, V2, V3, V4, V5, and V6 in the next 4 seconds with ST Map displayed on the right. The 1 lead-rhythm is recorded at the bottom for 10 seconds.
1CH+3	Rhythms I, II, III, aVR, aVL, aVF, V1, V2, V3, V4, V5, V6 are recorded for 0.83 seconds each, and a 3-lead rhythm is recorded for 10 seconds at the bottom.

Rhythm Channel (Rhythm CH1, Rhythm CH2, and Rhythm CH3)

Set the rhythm-representative lead used in the 3CH+3, 3CH+1, 6CH+1, 6CH+1 (ST), 1CH+3 form for diagnosis printout. The 3CH+3 setting uses all 3 selected values, and only the first value is

used for the 3CH+1 and 6CH+1 settings.

By default, it is set to II, V1, and V5. As for 3CH+1, 6CH+1, and 6CH+1 (ST), II is used. All II, V1, and V5 are all used for 3CH+3.

Beat Form

Select between Text, Guide, Vector, and ST Map as additional print form after a diagnosis is printed.

Printing speed is normally fixed at 50mm/sec regardless of the Output Speed setting.

Print Format	Description
Text	A representative beat and each diagnostic parameters are printed.
Guide	The representative beat and each diagnostic parameter are printed, along with a diagnostic guide for arrhythmia.
Vector	The representative beat and each diagnostic parameters are printed, marking QRS Vector with an arrow.
ST Map (Bar)	The representative beat and each diagnostic parameters are printed, drawing ST map in the form of Bar.
ST Map (Dot)	The representative beat and each diagnostic parameters are printed, drawing ST map in the form of Dot.

Presentation Format

Set the presentation format of 12-lead ECG.

Presentation Format	Description
Standard	12-lead ECG is presented in the standard order: Leads I, II, III, aVR, aVL, aVF, V1,V2,V3,V4,V5 and V6.
Cabrera	12-lead ECG is presented in the Cabrera order: Leads aVL, I, -aVR, II, aVF, III, V1,V2,V3,V4,V5 and V6.

Rhythm Form

Set the real-time printout form.

Print Format	Description
3CH	3 leads are printed simultaneously. I, II, and III are printed first, and to change the printing lead, press the RHYTHM key on the control panel again. Each time you press the [RHYTHM] key, the sequence changes to I~III → aVR~aVF → V1~V3 → V4~V6 → I~III, and so on.
6CH	6 leads are printed simultaneously. I~ aVF are printed first, and to change the printing lead, press the [RHYTHM] key on the control panel again. Each time you press the [RHYTHM] key, the sequence changes to I~aVF → V1~V6 → I~aVF, and so on.
12CH	12 leads are printed simultaneously.

Note

To change the printing lead with the RHYTHM key in 3CH and 6CH settings, the Rhythm Size must be set to Continue.

Rhythm Report (Rhythm Size)

Sets the report size of the real-time print.

- Report: About 10 seconds of data are printed in Report format.
- Continue: The pre-set lead is continuously printed until you press the [ESC] key on the control panel.

Note

When Rhythm Size is set to Report, the printing speed is fixed at 25.0mm/sec.

The followings are examples of print formats:

Rhythm Report Form (3 CH)



Rhythm Report Form (6 CH)

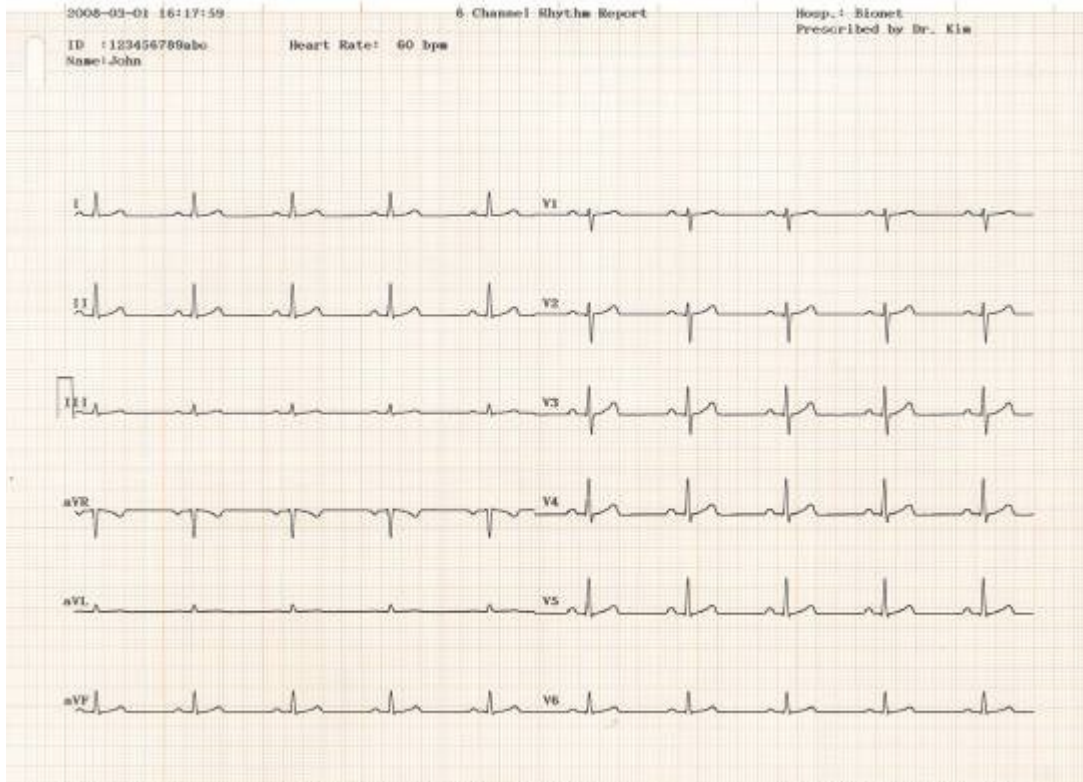

Rhythm Report Form (12 CH)

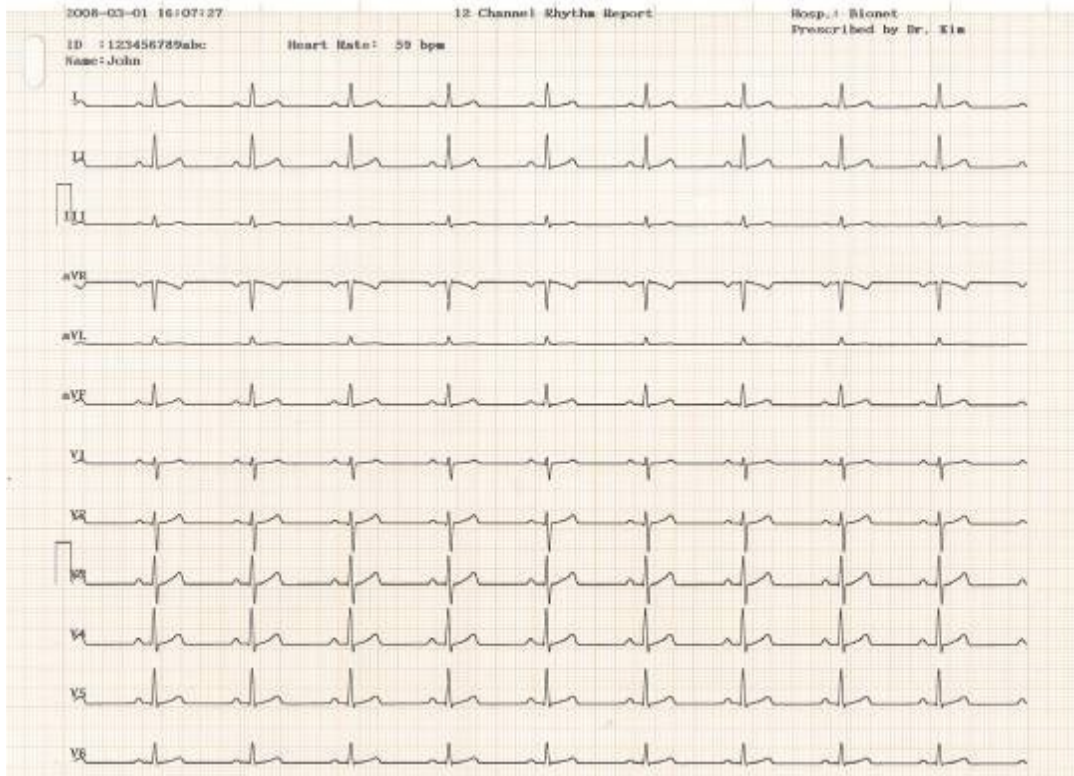

Record Report Form (3 CH + 1 RHY)

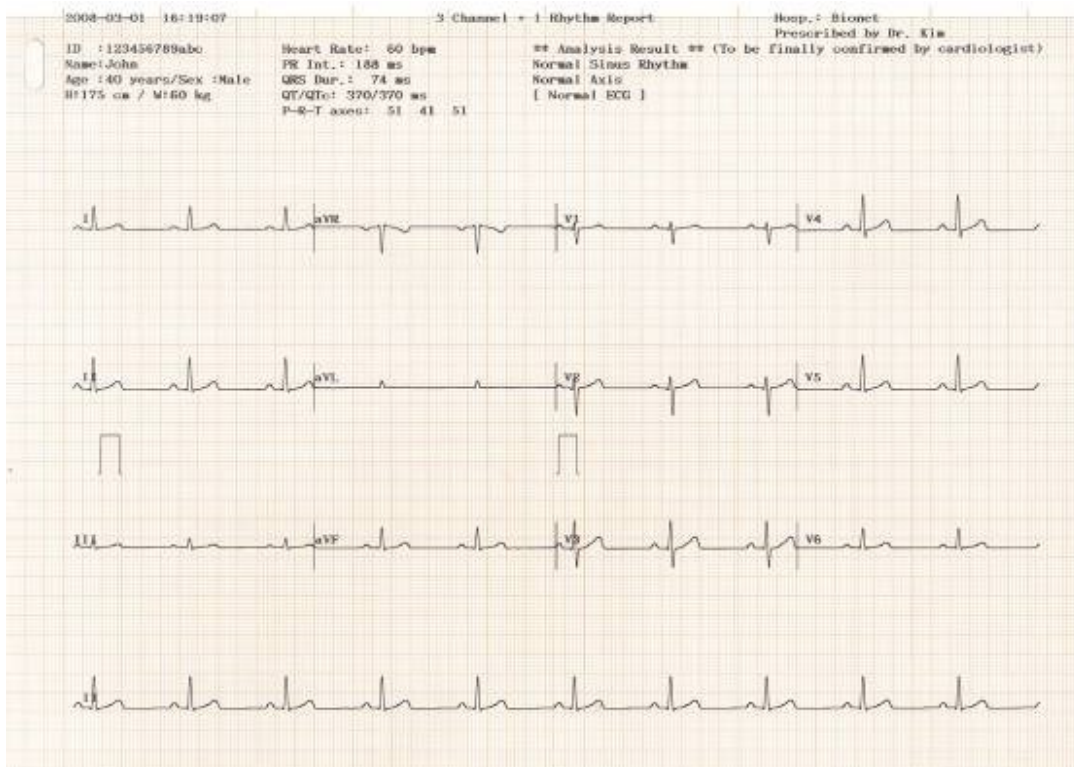

Record Report Form (3 CH + 3 RHY)

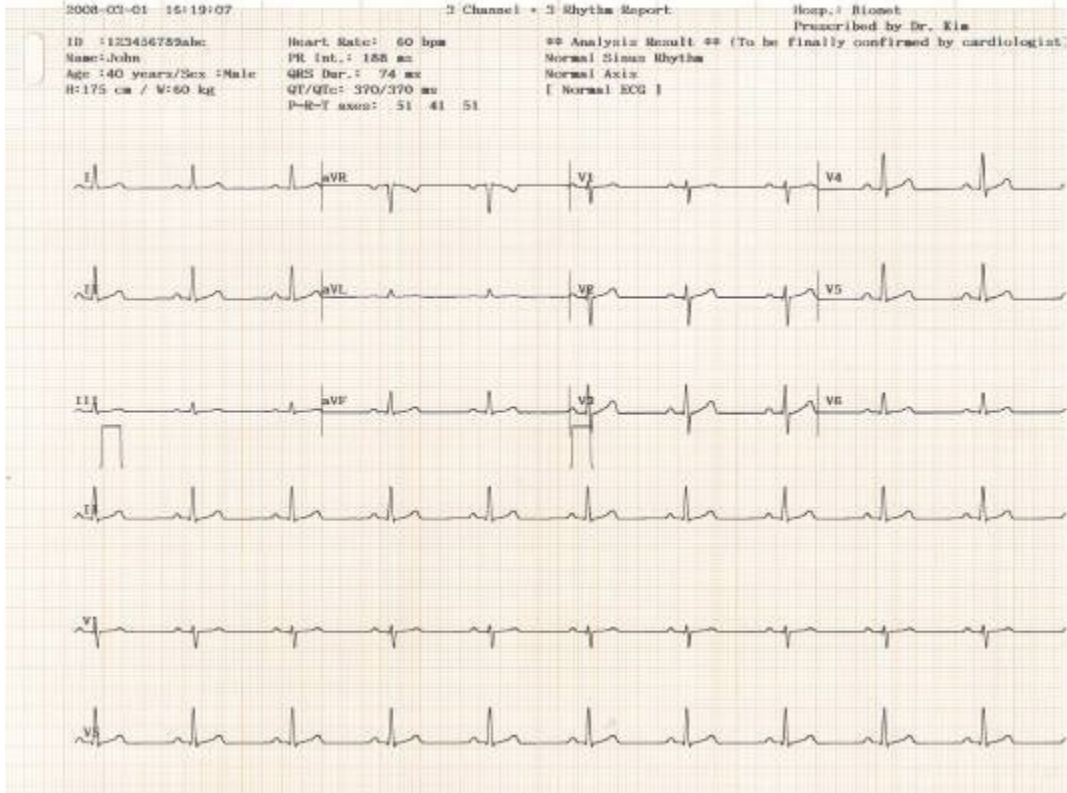

Record Report Form (6 CH + 1 RHY)

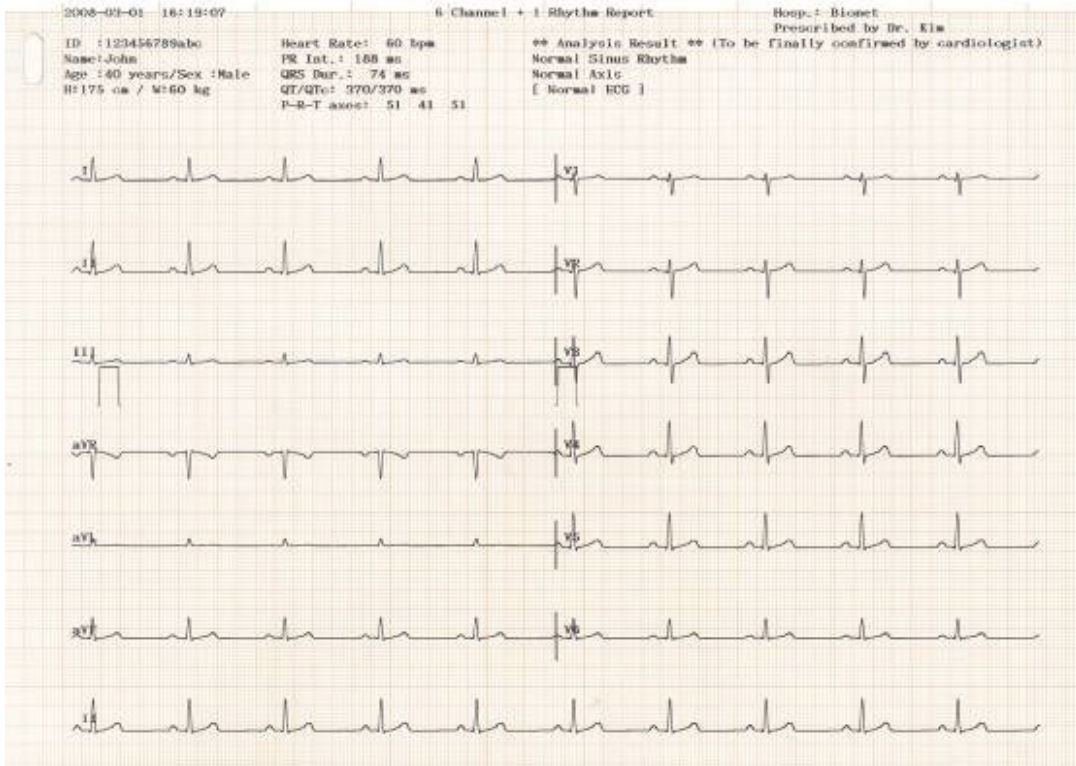

Record Report Form (12 CH)

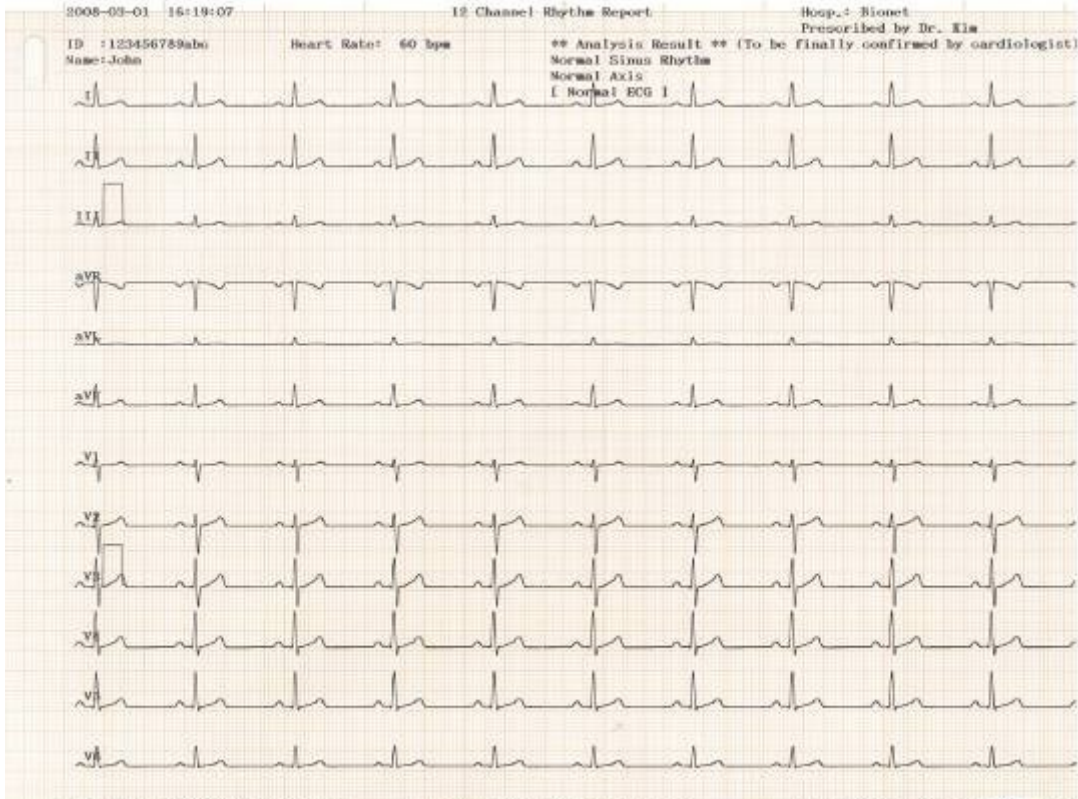

Record Report Form (6 CH + 1 RHY (ST Map))

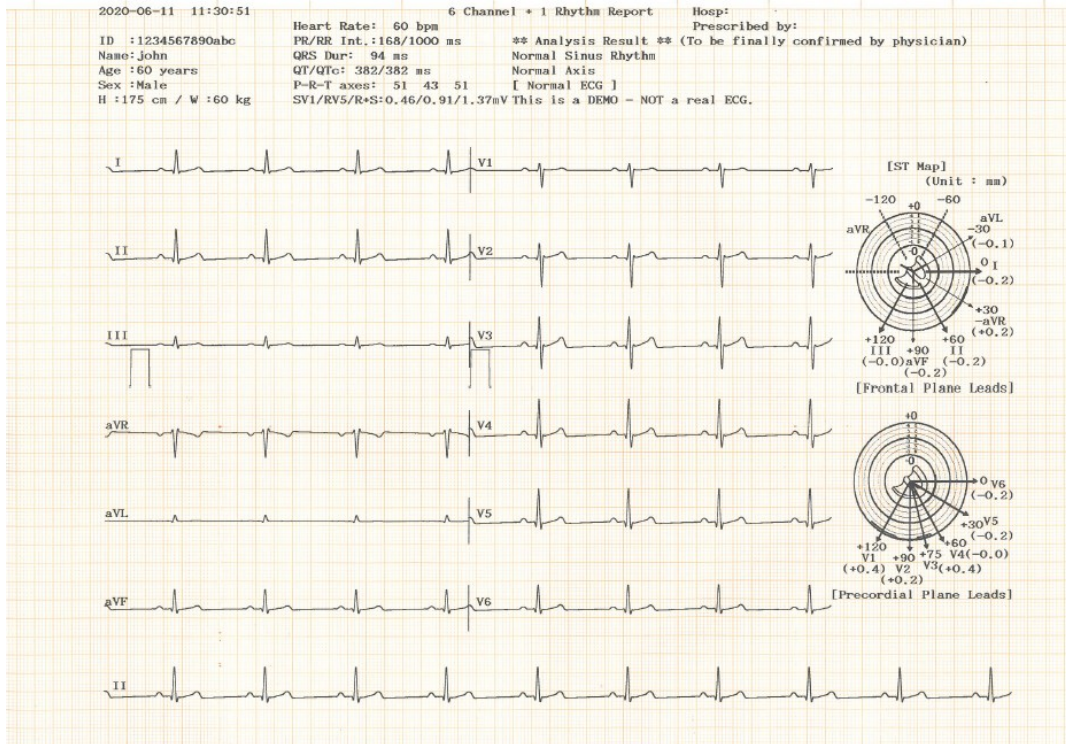

Record Report Form (1 CH +3)

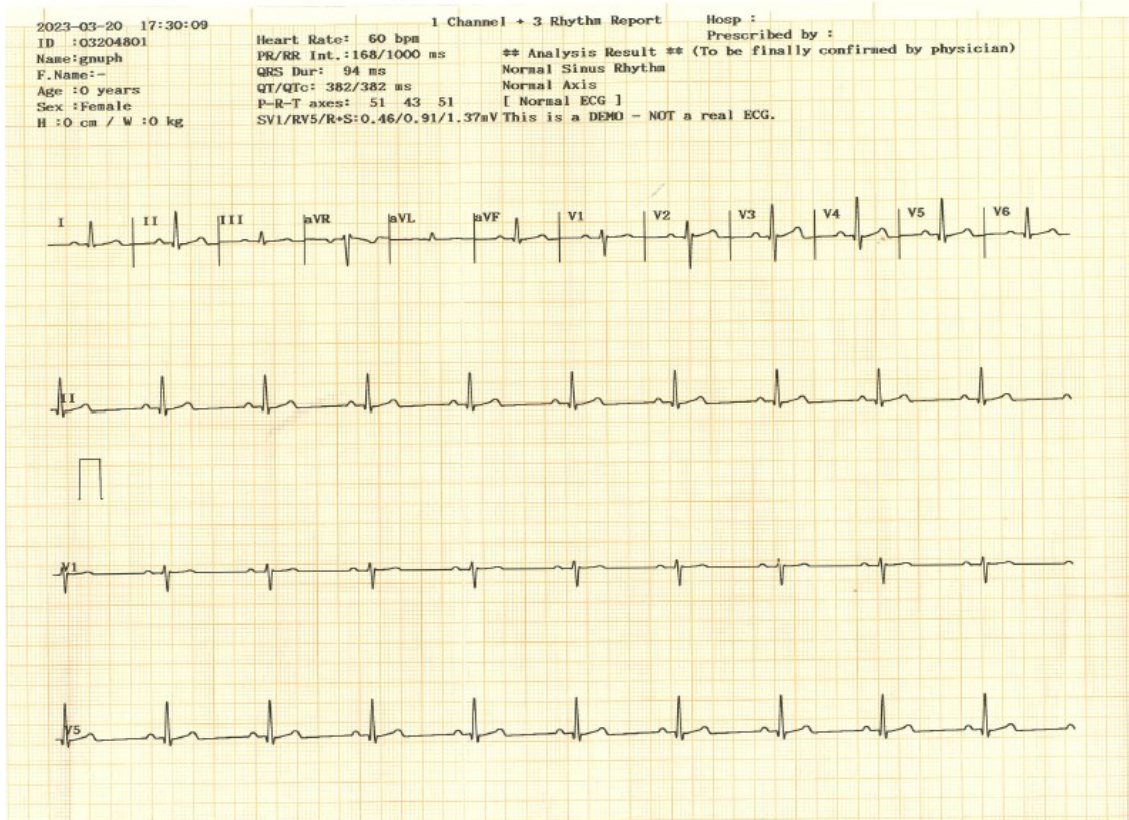

Record Report Form (Cabrera Report)

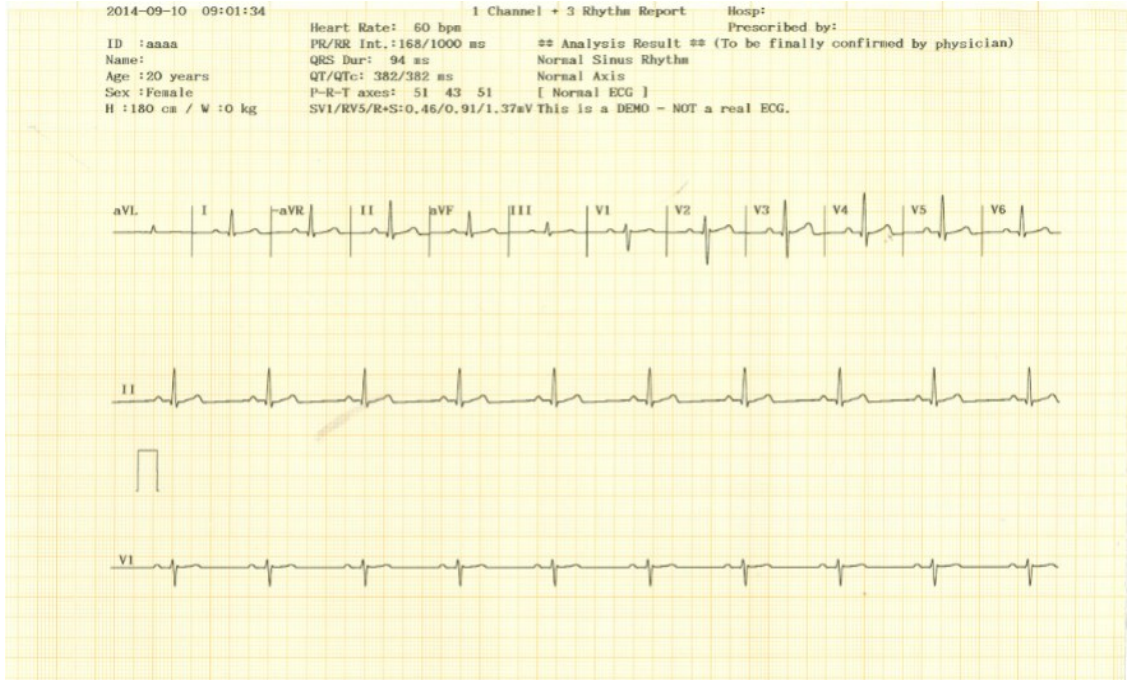

Record Report Form (BEAT REPORT - TEXT)

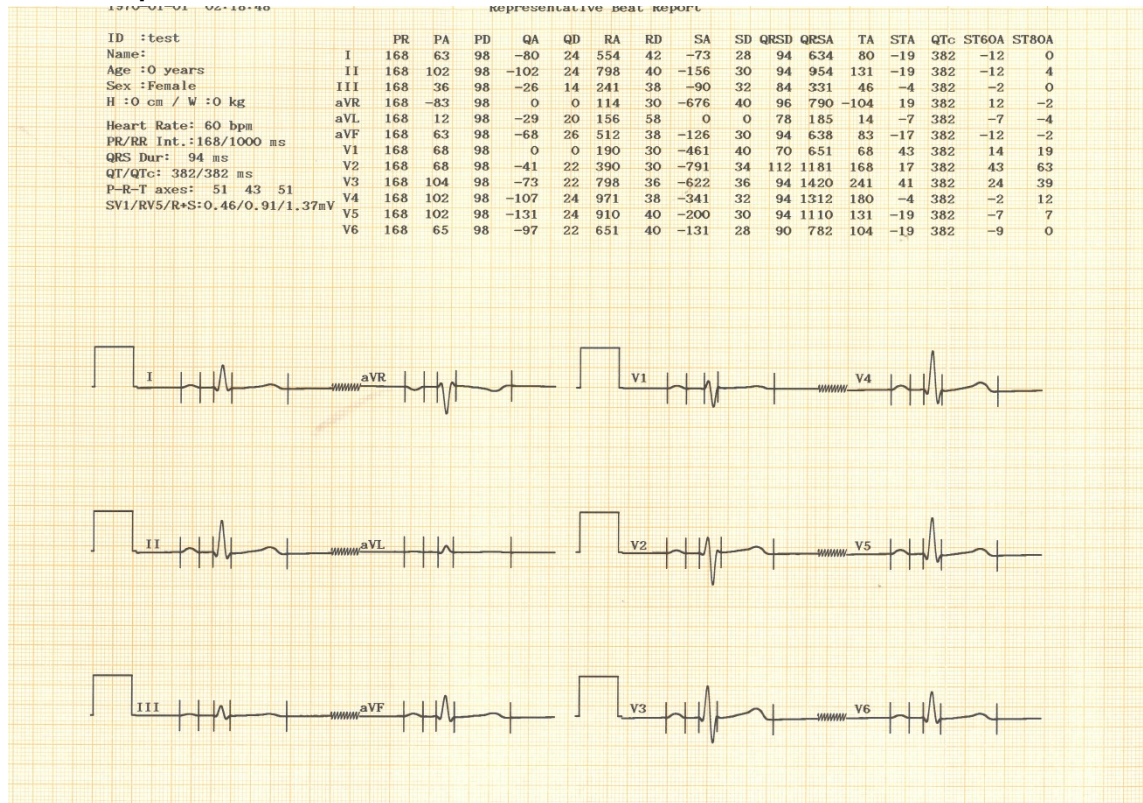

Record Report Form (BEAT REPORT - VECTOR)

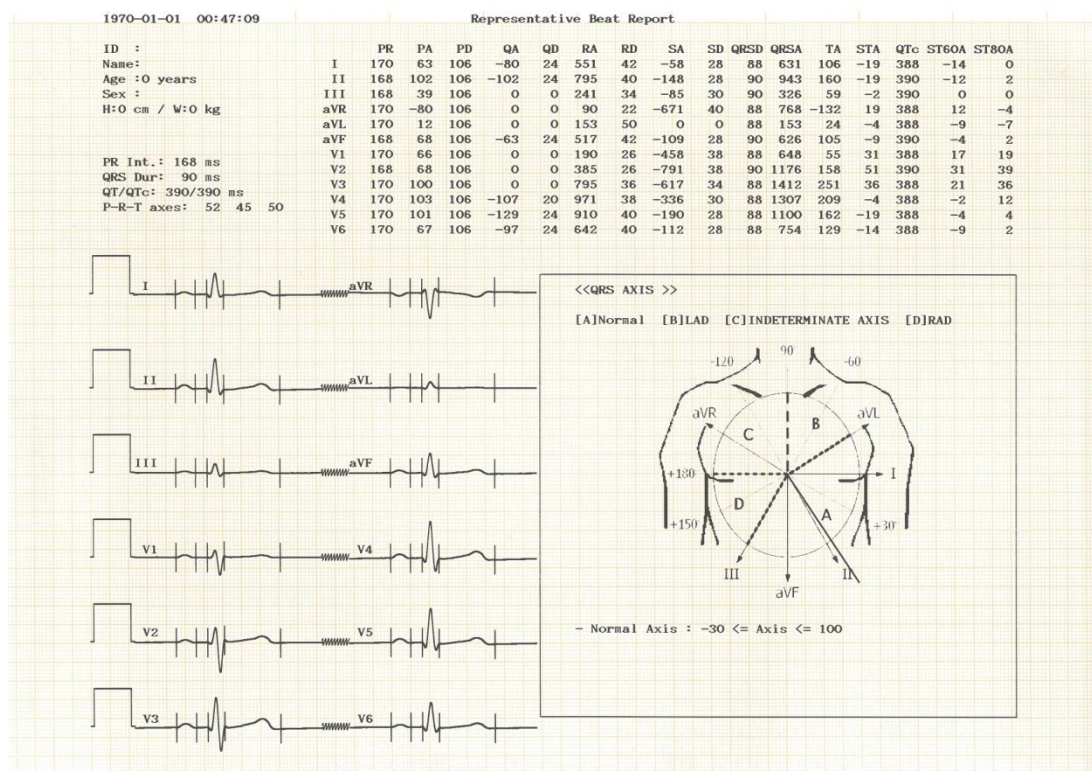

Record Report Form (BEAT REPORT - GUIDE)

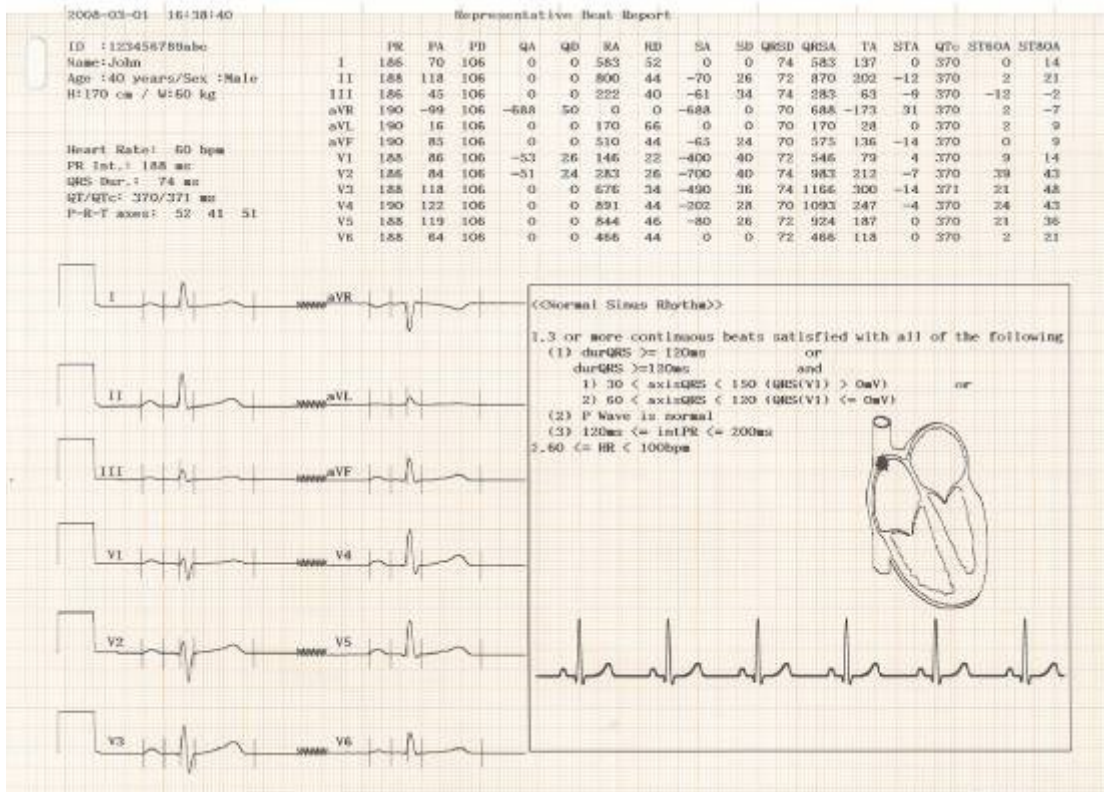

Record Report Form (BEAT REPORT -ST Map (Dot))

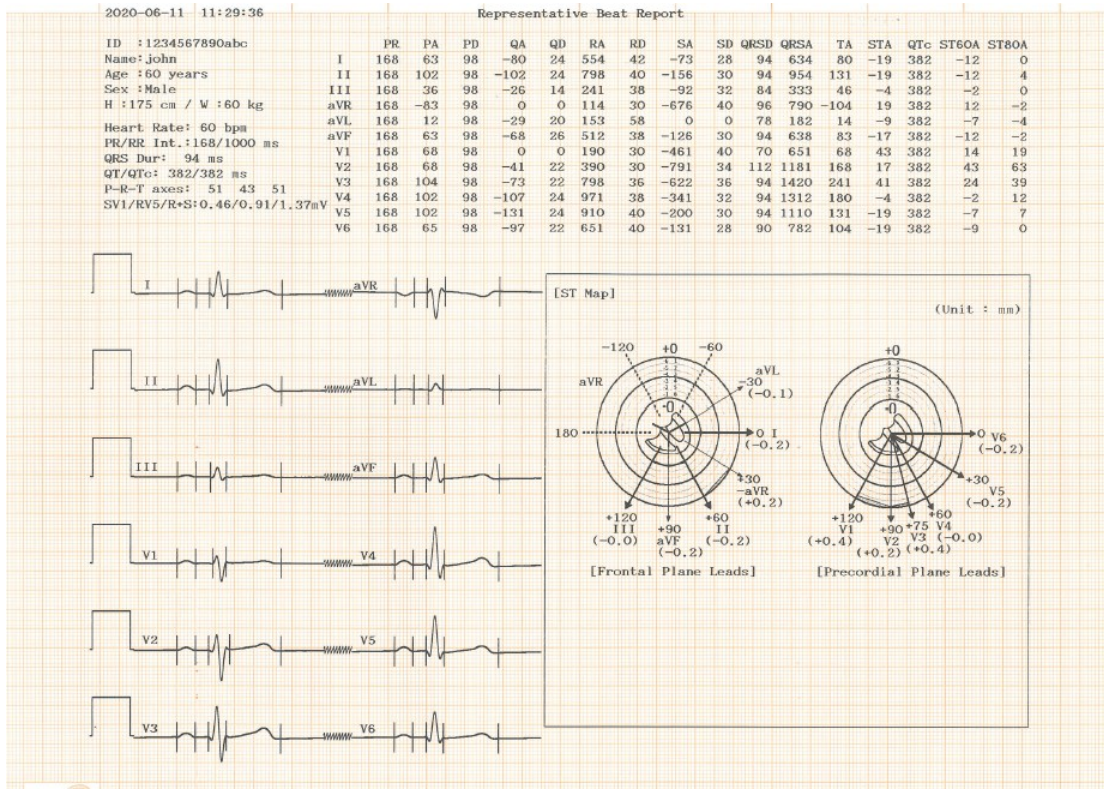

Record Report Form (BEAT REPORT -ST Map (Bar))

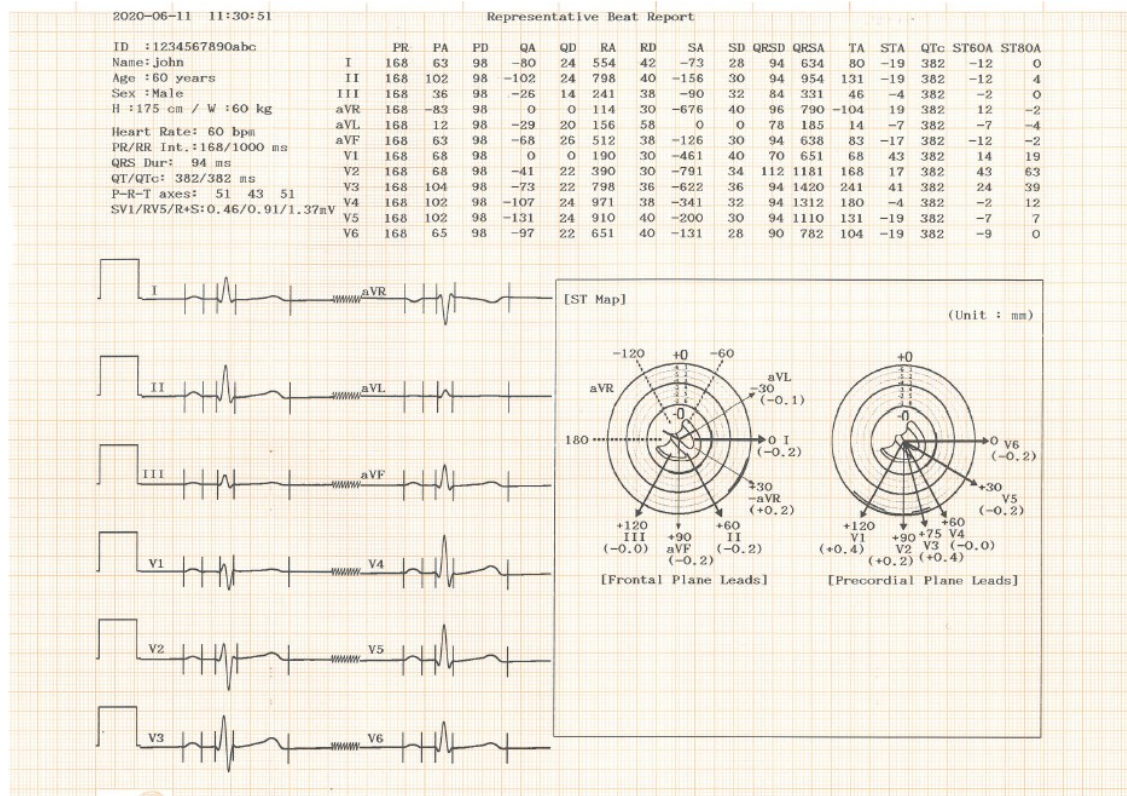

9-1) Explanation of BEAT REPORT Variables

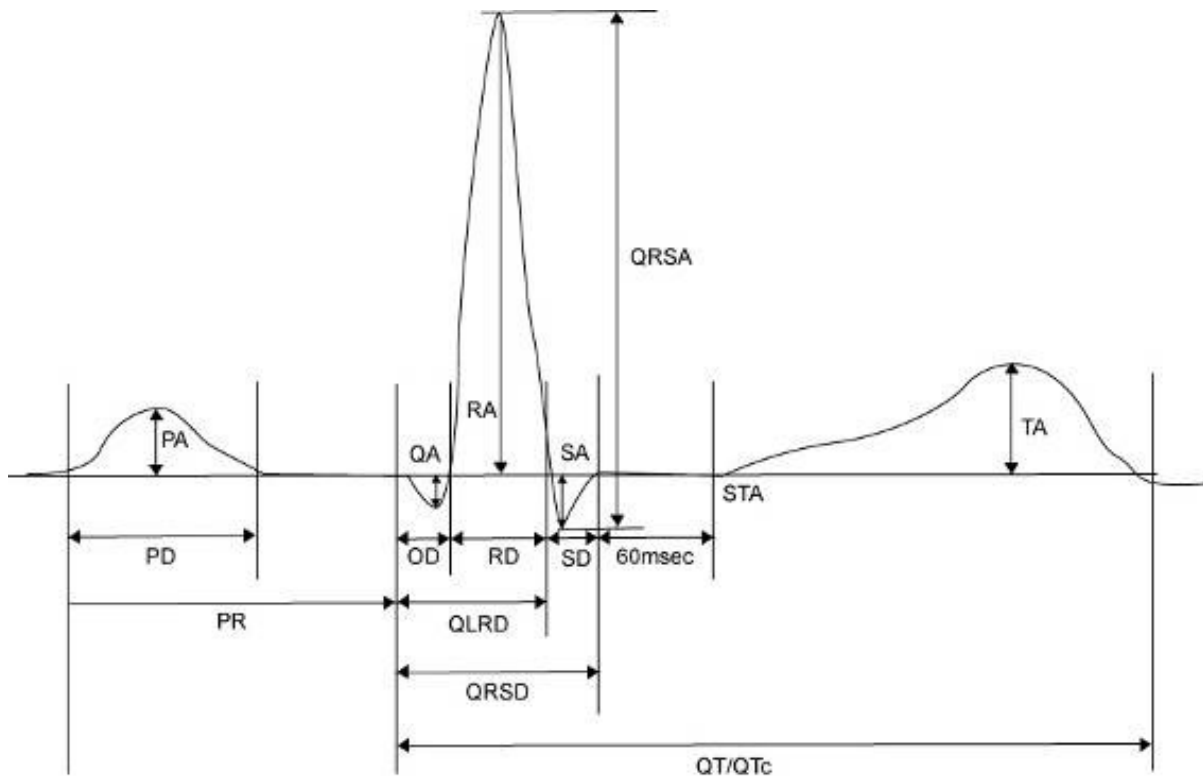

- PR: PR Interval
- PA: Amplitude of P Wave (P Amplitude)
- PD: Duration of P Wave (P Duration)
- QA: Amplitude of Q Wave (Q Amplitude)
- QD: Duration of Q Wave (Q Duration)
- RA: Amplitude of R Wave (R Amplitude)
- RD: Duration of R Wave (R Duration)
- SA: Amplitude of S Wave (S Amplitude)
- SD: Duration of S Wave (S Duration)
- QRSD: Duration of QRS Wave (QRS Duration)
- QRSA: Amplitude of QRS Wave (QRS Amplitude)
- TA: Amplitude of T Wave (T Amplitude)
- STA: Amplitude of ST Wave (ST Amplitude)
- QTc: Correct Q-T Interval (collect Q-T Interval)
- ST60A: Amplitude of ST+60ms (ST60ms Amplitude)
- ST80A: Amplitude of ST+80ms (ST80ms Amplitude)

Note

The unit of parameter intervals (duration, interval) used in the Beat Report is *ms*, and the unit of height (amplitude) is *μV*.

Note**Dextrocardia**

Normally, the heart is located in the left chest. However, there are cases where the heart is located in the right chest, which is called Dextrocardia.

You may suspect Dextrocardia in the following cases:

- If P, QRS and T are all reversed in Lead I
- If aVR and aVL are switched, and lead II and III are switched
- If R wave becomes smaller from V1 to V6 in chest lead

For Dextrocardia patients, change the electrode positions and measure as follows to obtain auto diagnostic results correctly.

- Switch the electrodes on right hand (R) and left hand (L).
- Attach the chest lead from the left in order, which used to be attached from the right.

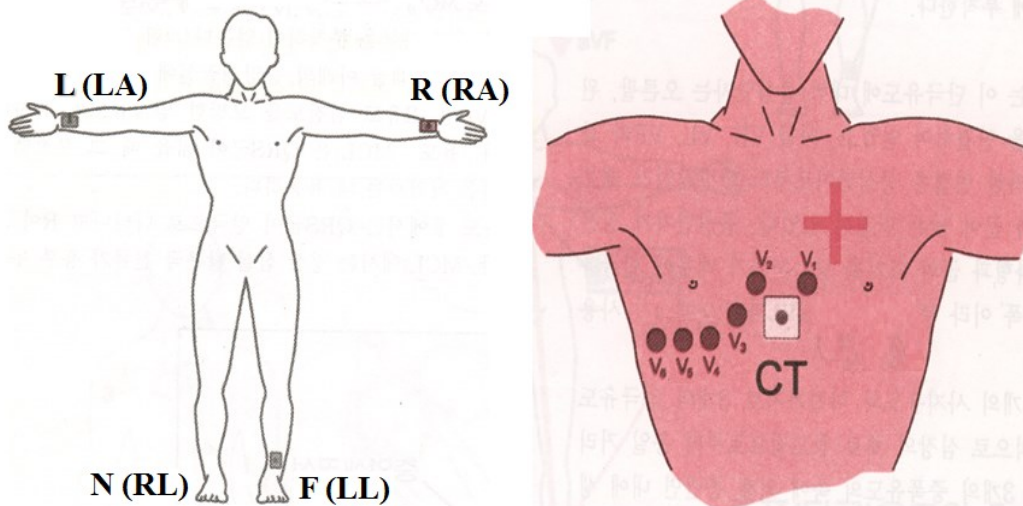

10) Printing Diagnostic Copy (COPY key)

You can reprint the saved data with the same settings as before, or print it by changing its settings of Filter, Gain, Output Speed, Channel Configuration, Rhythm, etc.

When the diagnosis is issued, press the [COPY] key on the control panel to print a report with the changed settings applied to the saved data.

Note
You cannot use [COPY] key function if you change the diagnosis mode after a diagnosis is issued.

If you change the filters on a previously saved ECG, it will adapt to the new filter. When the new filter is adapted completely, it will start printing after showing the message as below.

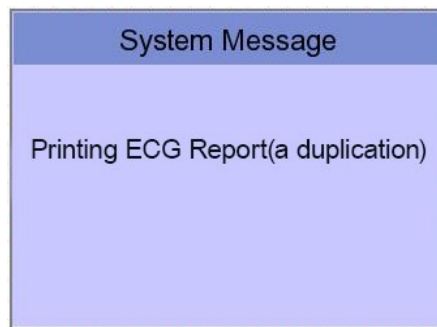

When printing is abnormally completed, the state of the system setting will be displayed after showing the message as shown below for a second.

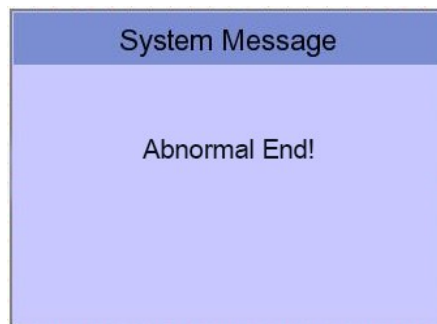

If you want to stop the process of printing, press the [ESC] key. Then the process will stop, and you will see the ECG Main page after the message shown for a second as below.

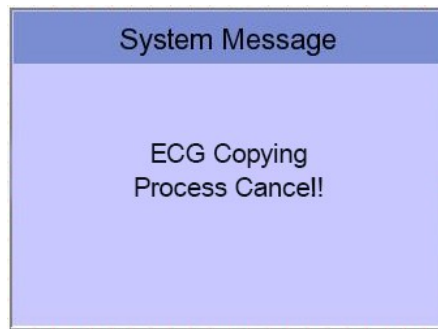

11) System Setup

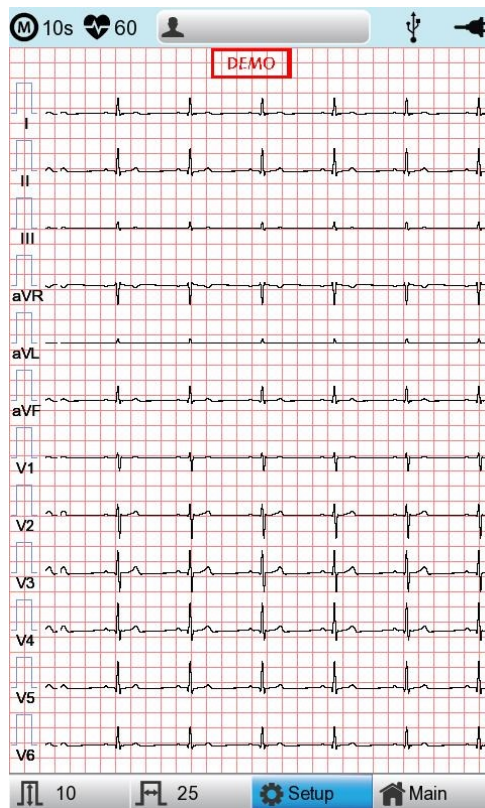

Choose the 'Setup' button on the initial ECG main screen to change preferences.

Setup menu consists of Basic Setup, Network Setup, Hospital Setup, ECG Setup, Record Setup and Service Setup and you can change the setting at each window. The main page shows Basic Setup.

After finishing the settings, press [OK] to save the new information or press [Cancel] to cancel it. You can choose [Exit] or [ESC] button to exit from the setup menu.

[Default] button is used to default every setting.

11-1) Basic Setup

When choosing Basic menu at the left side of the Setup page, you will see the page for Basic Setup.

Basic Setup consists of Date, Time, Touch screen, Start Option, Unit, Date Type and Device Name menus.

The screenshot displays the 'Basic' setup screen. On the left is a vertical menu with buttons: Basic, Network, Hospital, ECG, Record, Service, and Exit. The main area contains the following settings:

- Date:** 1970 - 01 - 01 (Y-M-D)
- Time:** 00 : 01 : 08 (with a 'Setting' button next to it)
- TouchScreen** (button)
- Lang:** ENG (button)
- Start Opt:** Main (button)
- Units:** cm/kg (button)
- Date Type:** Y-M-D (button)
- DeviceName:** (text input field)
- Device ID:** (text input field)
- OK**, **Cancel**, and **Default** (bottom buttons)

11-1-1) Setup date and time

After choosing the Setup menu, press the Basic button then the focus will go to the 'Date' item. By using the touch screen or rotating the rotary switch, choose the Date (yyyy/mm/dd) or Time (hr/min/sec), then the keypad will show up. You can set up the information by using this keypad.

The Focus will go 'year → month → day → hour → minute → second' consecutively.

If you press the Setting button, you can use the NTP function to get the time from the network and the Time Zone function to set the time of the area where the equipment is installed.

Note

- When the Time Zone setting is changed, the device is rebooted for stable operation.
- Depending on the network condition where the equipment is installed, it may take a long time for the NTP function to be activated for the first time.
- The NTP function does not work unless an exception is handled by the firewall.
- When using the NTP function, the initial time must be set to the current time. If the difference between the set time and the current time is large, the initial setting may take a long time.

11-1-2) Touch Setup

This is a menu to set up the coordinates of the touchpad. When selecting the 'Touch' menu at the Basic Setup page, setup page will disappear and the coordinates for setting calibration will appear as shown below. Follow the instructions shown on the screen, and then the coordinates will be set up.

Please input the information in the right place, otherwise the touchpad may not work properly.



Note
When the user selects the Touch Setup menu, all windows will disappear, and the touch screen setup will start. No keys will be operational until the Touch Setup is complete.

11-1-3) Language

when selecting 'Language menu at the Basic Setup page, you can choose the language among English, French, German, Italian, Korean, Polish, Portuguese, Rumanian, Russian, Spanish and Turkish.

Select the language you want to use and click the OK button and then you can use the service in the chosen language.

Note
Patient information previously entered will be initialized if the language preference is changed.

Note
If language preference is set as "KOR," only the menu on the LCD screen will be shown as Korean, whereas the output will be in English when printing out.

11-1-4) Start Option

Set the initial screen that appears when the equipment is turned on.

When clicking the 'Start Option' button, a small menu window will appear and you can Select the most frequently used function among MAIN, FILE, WORKLIST, ECG, SPIRO.

11-1-5) Units

This menu is to select the units for height and weight of the patient. When you click Units' button, cm/kg or Inch/Lbs will be shown.

If you select Inch/Lbs unit, the patient's height information will be expressed in *** Ft(Feet) *** Inch.

11-1-6) Date Type

As seen in the figure below, the date format on the top of the paper can be changed while printing out monitoring and recording results if you choose 'Date Type' from the Basic Setup menu. Choose the date format to be used, and then click the 'OK' button; the date format is converted to the one selected and can be seen on the output.

11-1-7) Device Name Setup

'Device Name' refers to the name of the device. The user can input the name of the device in order to distinguish devices on PC easily.

'Device ID' cannot be revised by the user as it is a unique ID of the device and is used to identify devices on a PC. 'Device ID' is automatically set for easy identification of devices on the connected

PC; therefore, it cannot be revised by user.

11-2) Network Setup

When connecting the equipment with LAN to interface with the outside PC, network setup is needed. Network IP is required, and DNS is not used.

When selecting the Network menu at the left side of the System Setup page, Network Setup page will show up at the right side.

The mode of network connection can be selected as Wired or Wireless in 'Net Device' setup.

The automatic IP(DHCP) or fixed Manually) can be selected through the 'Configure'.

If the Configure is setup as automatic IP(DHCP), the Device IP, Subnet Mask, Gateway value is received automatically from the DHCP server on your network. If the Configure is set to manually, the user has to enter the Device IP, Subnet Mask, Gateway directly.

When selecting one of the 'Device IP', 'Subnet Mask', 'Gate Way', the keypad will show up. Then, input the information required and press [OK] button to save or [ESC] to cancel the information.

It allows selecting the server which is available to link with the equipment in the 'Connect to' menu.

After selecting the type of interlocking server, select the [Setting] button; an appropriate setup window to the choice of server will be displayed.

Note

To connect to the PACS server, you must enter the Device IP manually. If the IP is set to DHCP, the device IP may change every time the device is turned on. If the changed IP is different from the device IP registered in the PACS server, server connection may not be made.

11-2-1) BMS Server Setting

IP setup on BMS Server-installed PC can be performed by choosing either Automatic IP (DHCP) or Fixed IP (Manually) in 'Configure' setup.

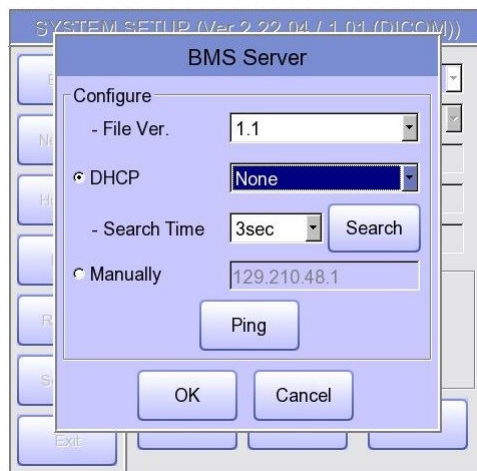

The patient's surname is available after changing the file version to 1.1 in the BMS Server settings.

If you change the file version, all existing patient data will be deleted.

If 'DHCP' is chosen, the IP of the BMS Server-installed PC will be shown on the input box.

Choose the IP of the PC you intend to connect as the IP of a BMS Server-installed PC:

If multiple IPs are displayed, choose one belonging to the PC to connect.

At that time, IP will be shown on the input box only if BMS Server is running on the PC.

If no IP of the intended BMS Server to connect is shown on the input box, choose

'Search' button to conduct an additional search.

If no IP of the intended BMS Server to connect is shown on the input box, choose 'Manual' mode to perform manual input.

Note

If you change the file version, patient data and work list data will be deleted.

Upon completion of BMS Server IP setup, the Ping Test can be conducted to check successful network connection. If choosing 'Ping' button, "Ping: 100% Succeeded" message will be shown for a successful connection, whereas "Ping: Failed" message will be shown for connection failure.

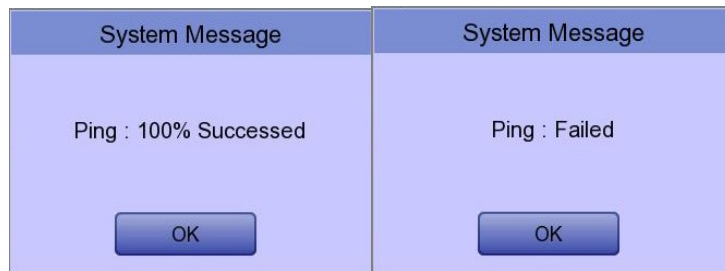

Note

- Wired usage is recommended for a BMS Server-installed PC network.
- When setting BMS Server, directly enter the IP of the BMS Server-installed PC by selecting "Manually" if searching with DHCP has failed.

11-2-2) PACS Server Setting

When selecting the PACS Server, the additional information should be set through the Settings Menu.

The screen for related settings such as the AE Title, IP and Port of Cardio7, Worklist Server and Store Server will appear.

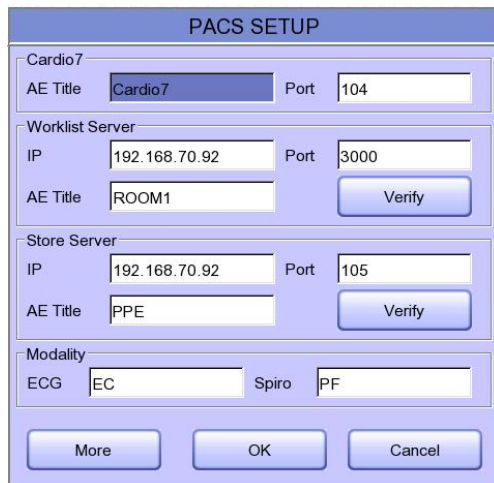

When the input window of each item is selected, the keyboard window will appear:

Enter the applicable contents.

When entry is completed, click the "Verify" button so that the connection between the Worklist Server and the Store Server can be confirmed.



When successful, the "Verify: Success" message will appear; when it has failed, "Verify: C-Echo Failed" will appear.

Set the PACS option by pressing the More button when connection to the server is confirmed.

 A dialog box titled "PACS OPTION SETUP" with a blue header. It contains several sections:

- Worklist:** "Spiro Exam Code" with input fields for FVC (selected), SVC, and MVV. "Date Range" is set to "Today". There are checkboxes for "Auto Update Worklist" and "Auto Return Worklist", both of which are unchecked.
- Send Image:** "RGB Format" has radio buttons for "RGB" (selected) and "BGR". "Window Width" is 256, "Window Center" is 128, and "Data Format" is JPEG.
- Retry:** "Retry Count" is 3 and "Retry Interval" is 1.
- Character Set:** Set to "Auto".

 At the bottom are "OK" and "Cancel" buttons.

Spiro Exam Code

Enter the Exam Code of FVC, SVC and MVV for the Spiro test.

Date Range

The range of dates when the worklist is brought can be set at the Worklist Server.

You can choose appropriate one from the options such as "Today," "Yesterday ~

Tomorrow", "One Week" and "A Week ago".

For today (today-today), both the start and end dates are set to today, and for today (today-blank), only the start date is set to today to get the worklist.

Auto Update Worklist

If you tick the Auto Update Worklist, the Worklist update will be run automatically whenever you enter the Worklist screen.

Auto Return Worklist

If you tick Auto Return Worklist, data will be transferred to the PACS Server and the Worklist screen will re-appear automatically by using the Exam button after selecting the patient to measure, or by using the NETWORK key or AUTO key after selecting the patient to measure.

RGB Format

Select the RGB Format when converting the image to be transferred to the PACS Server. The basic setting shall be "RGB"; if the Grid Color of the transferred file appears as green, it will be converted to the red color when the "BGR" is set.

Width / Window Center

Set the Window Width and the Window Center for the file to be transferred to the PACS Server. If the image of the transferred file appears blurred, check the Window Width and Center values which the PACS Server supports, and enter them.

Data Format

Set the data format for the file to be transferred to the PACS Server.

You can select either "JPEG," "PDF" or "RAW" after checking the format supported by the PACS Server.

Retry Count

Select the number of Retransmission attempts when a communication error occurs during transfer of data to the PACS Server.

Retry Interval

Select the interval for Retransmission attempts when a communication error occurs during the transfer of data to the PACS Server.

Character Set

By selecting the Character Set, multiple selections of language are available; it should

be selected according to the character set in order to present contents such as patient information by language when transferring a DICOM file to the PACS Server.

Upon the completion of each setting, press the 'OK' button to save the changes or push the 'Cancel' button or the 'ESC' button of the Operating Panel to cancel them.

11-2-3) GDT Setting

When selecting GDT, it should be set additional information through the Setting menu.

It shows the menu screen for related settings such as Work type, GDT Directory, Component name, File name, and Image type.

Work Type

Set the GDT operation of the equipment.

- Server: Cardio7 receives requests and commands.
- Client: Cardio7 sends requests and commands.

Directory

Enter the type of format in which the shared folder information and date information to be used by the GDT protocol.

Component

For use GDT protocol, enter the EMR name and abbreviation and the name of Cardio7 and abbreviation.

Short Name

Select the name type of the file to be shared by the GDT protocol.

Image

Select the image format for the data file to be shared by the GDT protocol.

Touch the input field of each item and enter values using the keypad window.

If you finish entering the inputs correctly, a connection success message is displayed at the top of the screen.

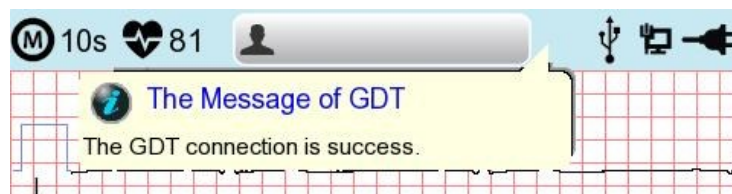
**11-2-4) WEB Setting**

When selecting Web transmission, additional information must be set through the Setting menu. The screen for related settings such as DNS Server, URL, ID, PW, Path appears.

A screenshot of a "Web Server" settings screen. The title bar is blue with the text "Web Server". Below the title bar, there are five input fields: "- DNS Server" with the value "8.8.8.8", "- URL", "- ID", "- P.W", and "- Path". To the right of the "- ID" and "- P.W" fields is a "Verify" button. At the bottom of the screen are "OK" and "Cancel" buttons.

DNS Server

The IP of the server that supports the domain name system.

URL

Web address to access.

ID

User ID to be used in the web to be accessed.

PW

User password to use on the web to be accessed.

Path

Path within the server to which to send the file.

If you select the input window of each item, a keyboard window appears, and you can enter the content.

After entering, you can check the connection between Worklist Server and Store Server by pressing the [Verify] button.

The message "Verify: Success" is displayed on success, and the message "Verify: Fail" on failure.

11-2-5) Wireless Network Setting

The screenshot shows a software interface for configuring a wireless network. On the left is a sidebar with buttons for 'Basic', 'Network', 'Hospital', 'ECG', 'Record', 'Service', and 'Exit'. The main window is titled 'Wireless Network Setting' and contains the following fields:

- Net Device:** A dropdown menu set to 'Wireless'.
- Configure:** A dropdown menu set to 'Manually'.
- Device IP:** A text input field containing '129.210.48.4'.
- Subnet Mask:** A text input field containing '255.255.240.0'.
- Gate way:** A text input field containing '129.210.53.1'.
- Connect to:** A section containing a dropdown menu set to 'BMS' and a 'Setting' button.

At the bottom of the dialog are three buttons: 'Search', 'OK', and 'Cancel'.

- (1) Connect the USB to the USB port of Cardio7, and check whether or not the wireless icon

() appears in the Status bar on the top of the screen.

- (2) Navigate to System Setup -> Network, and Set the Device as "Wireless". When selection is done properly, the "Survey" button on the bottom will be activated.
- (3) Select the [Search] button to search for the AP. The AP is to be searched automatically when the "Search" button is pressed: the searched AP will appear in the list upon the completion of the search.

Specifications of Wireless Network USB Adapter Support

Company Name	Product Name
ipTIME	N100mini
	N150UA
	N150U
TP-LINK	TL-WN725N



- **Refresh : AP re-searching**
- **<< : Page up**
- **>> : Page down**
- **Connect: Attempting to connect**
- **Close: Closing the window**
- **Add: Hidden Wi-Fi connection**

- (4) Select the AP to be connected by using the rotary key or touching. Click the [Connect] button. At that time, the security key input window will appear if the "Encrypt" field is "On".



The screenshot shows a dialog box titled "Add Network". It has a blue header bar with the title. Below the header, there are three sections: "- Network Name :" with a text input field containing "BIONET"; "- Security :" with a button labeled "WPA/WPA2-Personal"; and "- Password :" with an empty text input field. At the bottom, there are two buttons: "OK" and "Cancel".

If you want to connect to Hidden Wi-Fi, click the [Add] button and manually enter the network name before proceeding.



The screenshot shows a dialog box titled "Add Network". It has a blue header bar with the title. Below the header, there are four sections: "- Network Name :" with an empty text input field; "- Security :" with a button labeled "WPA/WPA2-Enterprise"; "- Identity :" with an empty text input field; and "- Password :" with an empty text input field. At the bottom, there are two buttons: "OK" and "Cancel".

Note

Search for an AP and set up a security key to use a wireless network.
If the AP to connect to does not require authentication, you are automatically connected with no need to enter the security key.
Automatically connected APs without security keys do not guarantee communication security.

(5) After clicking the Key Value input line by using the rotary key or touching, enter the security key.

(6) Upon the completion of input, click the [OK] button; Connection will be attempted and the message describing the connection status will appear.

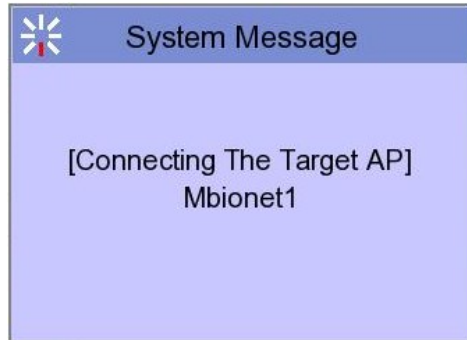

(7) When the message reporting a proper connection appears, click the [Close] button.

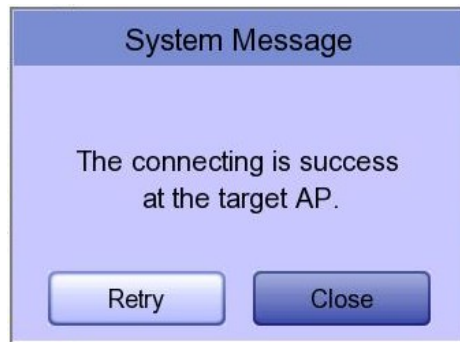

When connection is successful, the wireless icon on the status bar at the bottom of the screen will be changed into .

(8) If connection fails, connection can be re-attempted by pressing the [Retry] button. If connection keeps failing, check the AP and the USB-TO-WLAN status.



(9) When connection with the AP is successful, set the Device IP, Subnet Mask,

Gateway, etc. by selecting manually or Configuring with DHCP.

Refer to the Network Setup part of the User Manual for more details.

Note
Bionet recommends using English alphabet to name the wireless network (SSID) of the AP. Inputs in Korean or other languages can be shown broken or as strange characters.

Note
<ul style="list-style-type: none">• When using a general AP, it is recommended to connect up to 8 devices to the same network.• Due to the nature of wireless connection, connection may not be stable depending on the environment.

11-3) Hospital Setup

When selecting the 'Hospital' menu at the left side of the Setup page, Hospital Setup page will show up at the right side.

You can input the names of the hospital and doctor.

When clicking the area to input the information, the keypad will show up. Then you can input the information required and press [OK] button to save or [ESC] to cancel the information.

The screenshot shows a software interface for hospital setup. On the left, a vertical menu contains buttons for 'Basic', 'Network', 'Hospital', 'ECG', 'Record', 'Service', and 'Exit'. The 'Hospital' button is selected. The main window displays 'Hospital' and 'Doctor' labels next to text input fields. The 'Hospital' field contains 'Bionet' and the 'Doctor' field contains 'Dr.kim'. At the bottom of the main window, there are three buttons: 'OK', 'Cancel', and 'New'.

11-4) ECG Setup

When selecting the 'ECG' menu at the left side of the Setup page, ECG Setup page will show up at the right side.

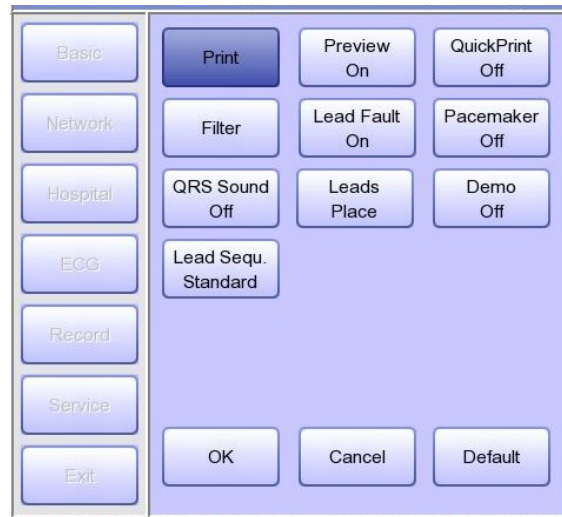

11-4-1) Printing channel setting [Print Setup]

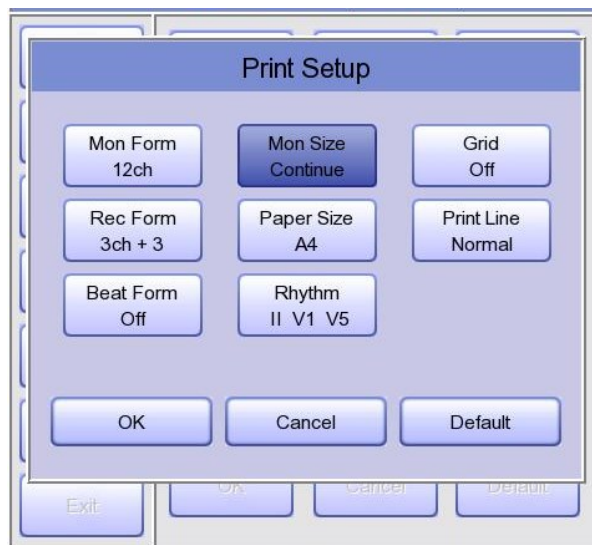

Monitoring Form (Mon Form)

Set up real time-printout form. Click 'Mon Form,' and then a POP-UP window for channel list will be displayed. Default is set as '12CH'.

- 3CH printing: To print 3 channels at the same time (I ~ III / aVR ~ aVF / V1 ~ V3 / V4 ~ V6) If you want to change the channel, press 'RHYTHM' on the control panel.
- 6CH printing: To print 6channels at the same time (I ~ aVF / V1 ~ V6) If you want to

change the channel, press 'RHYTHM' on the control panel.

- 12CH printing: To print 12channels at the same time (I ~ V6)

Note
To change the printing lead with the RHYTHM key in 3CH and 6CH settings, the Rhythm Size must be set to Continue.

Monitoring Size (Mon Size)

Sets the report size of the real-time print.

- Report: About 10 seconds of data are printed in Report format.
- Continue: The pre-set lead is continuously printed until you press the [ESC] key on the control panel.

Note
When Rhythm Size is set to Report, the printing speed is fixed at 25.0mm/sec

Grid

If general fax paper is used for printout, it needs to be marked with a grid. A 5mm X 5mm grid must be in a solid line with the point mark on the 1mm X 1mm location. If using standard ECG recording paper instead of general fax paper (thermal paper), undo the grid marking setup as the recording paper will already have it.

The grid marking setup can be done using output format selection mode. Press rotary key or touch the intended field to select among the Grid selection items, and then the setup will be modified as ON or OFF. If ON, the grid marks will be printed out; if OFF, it will not be printed out.

Recording Form (Rec Form)

See "Chapter 2. 9) Printing Form".

The set value will be displayed on the screen, and when you choose '3CH+1', 3 Channels + 1 Rhythm Report will be shown at the top of the printing form, '6CH+1' for 6 Channels + 1 Rhythm Report, '12CH' for 12 Channels Rhythm Report, '3CH+3' for 3 Channels + 3 Rhythm Report, '1CH+3' for 1 Channels + 3 Rhythm Report will be shown.

Paper Size

You can set up the paper size. When you click the 'Paper Size' menu, 'A4' will be selected and when clicking it again, 'Letter' will be selected. Default is set as 'Report'.

- 'A4': to output at 297mm for Report Size printout.
- 'Letter': to output at 279 mm for Letter Size printout.

Print Line

You can set the line thickness of the printouts. Three setting options are available: "Thin", "Normal" and "Thick".

Beat Form

You can set up the additional beat report printing.

When you select the 'Beat Form' menu, a small POP-UP menu will appear at the bottom and it will disappear when choosing OFF, Text, Vector, Guide, ST Map (Dot) or ST Map (Bar).

Default is set as 'OFF'.

Beat report will be attached to the printing form of channels of '3CH+1', '6CH+1', '12CH', '3CH+3' and '6CH+1(ST)', '1CH+3'. It will record every important result by marking the representative waveform of each form.

Rhythm

You can set up the rhythm leads for printing out the diagnosis of '3CH+1', '6CH+1', '3CH+3' and Long Time (1,3,5,10 Minute). You can choose 3 rhythm leads and when '3CH+3' is chosen, you can use all of the 3 leads, while when '3CH+1', '6CH+1' or 'Long Time' is chosen, you can use the first value only.

Default is set as 'II, V1, V5', so when '3CH+1', '6CH+1' or Long Time is chosen, you can use the lead 'II' and 3CH+3 for lead 'II, V1, V5'.

If you choose 'Rhythm' menu, 'Rhythm Channel' window will be displayed as shown below.

At that time, select either the 'CH1,' 'CH2' or 'CH3' menu; and then choose one from Lead I ~ V6 in the select menu.

11-4-2) Preview

After performing measurements by using keys such as [RECORD], [AUTO] and [NET], the device can automatically show the outcome to the user. This function can be turned On or Off in this window.

When the preview setting is set to "On", the "Preview" screen will appear following data

collection with [RECORD], [AUTO] and [NET] keys. While "Preview" screen is showing, the user can perform print, save or transmit the data after clicking [OK], or no action after selecting [Cancel]

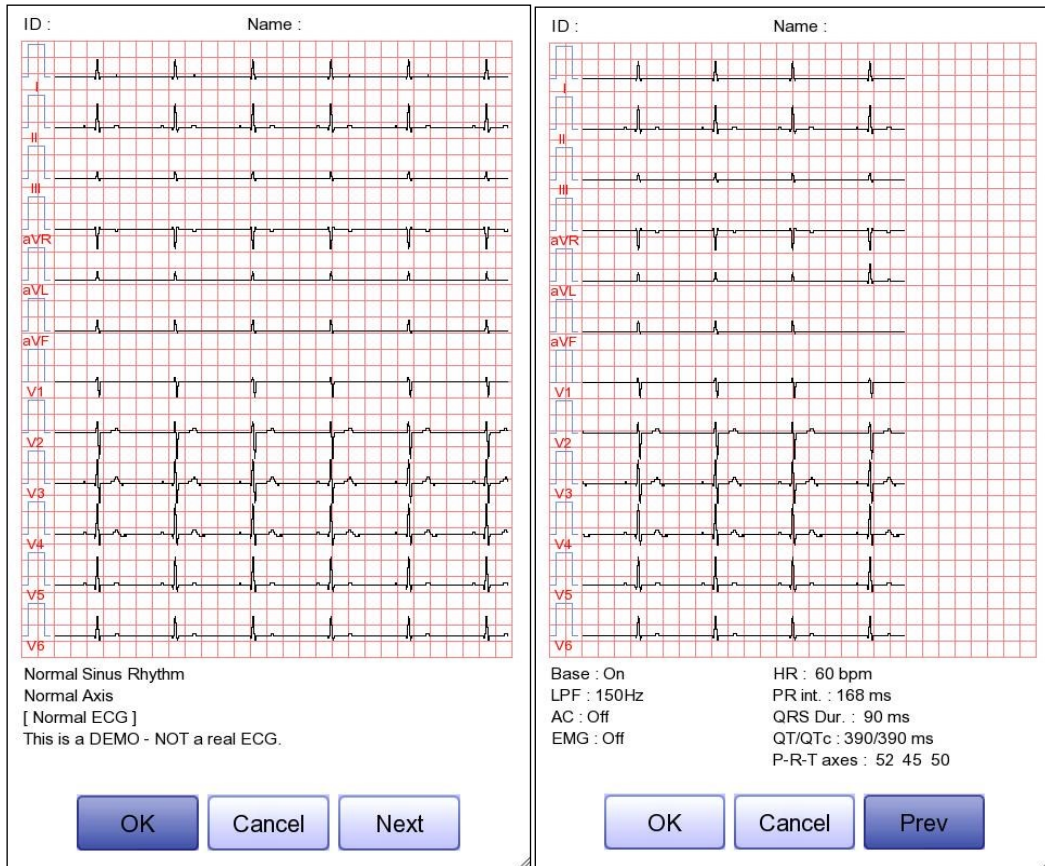

- The first page: ECG 0 - 6 seconds signal data, ID, Name, and Diagnosis
- The next page: ECG 6 - 10 seconds signal data, ID, Name, Filter setup, Rhythm parameter values

Note

The preview screen will be shown with output speed set to 25mm/sec.
The preview screen is available for 10-second recording only.

11-4-3) Quick Print

Set the Quick Print options. Since the data pre-saved for a set amount of time (0-10 seconds) is used, it takes less time to acquire data, reducing time to providing data.

Note	
–	With the Quick Print option set, touch the ON button when the signal stabilizes. Since the data pre-saved for a set amount of time is used, diagnosis and printing may be affected unless the saved data is stabilized.
–	Quick Print option is available only for 10-second recording. It cannot be used for long-term (1 minute, 3 minutes, 5 minutes, 10 minutes) recordings.

11-4-4) Filter Setup

The signal output generated by the device may contain extra unwanted signals in addition to the EKG wave such as AC noise, baseline drift caused by respiration, noise generated by an electrical field nearby, etc. Applying filters could help to reduce or remove those unwanted signals from the output of the device.

To change filter information, enter the Filter Setup Menu either by moving the selection block over and select it using the rotary key or by touching the menu on the touch screen.

Upon selection, the Filter Setup menu, shown below, will appear. Use either the rotary key or touch screen to navigate and select menu items to edit. After editing, OK must be selected in order to apply the changed value.

Baseline drift is caused by the patient's breathing. It can be seen as ECG signals being overlapped on a large parabola. The Baseline filter provides 0.05Hz, 0.1Hz and 0.2Hz, and its set values will appear as Base:0.05Hz, Base:0.1Hz and Base:0.2Hz at the bottom of the Output Form.

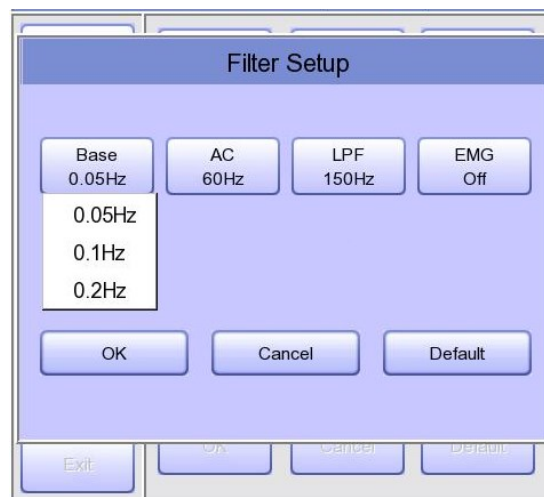

There are three types of an AC power noise filter: 60Hz, 50Hz and OFF. When set to OFF, the filter will not be applied. If the filter is set to 50Hz or 60Hz, then the AC filter will remove 50Hz or 60Hz power noise correspondingly. In the U.S., the AC filter should be set to 60Hz. Check the properties of your power source before setting AC filter properties.

Under battery power, there would be no AC noise being generated. In this case, please set the AC filter setting to OFF so that output signal would not be distorted.

The status of the AC filter can be checked on the bottom part of the printout - indicating AC 60Hz, AC 50Hz or AC OFF

If the recorded EKG signal contains a lot of noise, Low Pass Filter (LPF) may help to clear it. For Low Pass Filter, 40Hz, 100Hz, 150Hz and OFF option is offered. Here, 40Hz option means the filter will remove any unwanted signal with frequencies above 40Hz. Low Pass Filter values will appear on the bottom of the printout form; if LPF setting is OFF then as LPF: Off; if the LPF setting is 40Hz then as LPF: 40Hz; if LPF setting is 100Hz then as LPF: 100Hz; if LPF setting is 150Hz, then as LPF: 150Hz.

Select 'ON' when applying 'EMG' filter; otherwise, select 'OFF.' Setup values will be shown on the bottom of the printout form as 'EMG: On' or 'EMG: Off' when applying the filter.

Note
<p>Applying filters may distort the original signal. Therefore, the proper use when the recording signal is in bad condition can reduce ECG signal distortion.</p> <p>Referentially, it is recommended to apply the Baseline Drift filter and AC filter all times and that the Near Field filter is used properly. It is also recommended that the LPF be set to 150 Hz for diagnostic outputs.</p>

11-4-5) Lead fault Signal Display Setting

When the connection between the patient and Leads is improper, lead fault can occur. In that case, you can choose whether to have the lead fault message on the ECG Main page or not. Selecting 'Lead Fault' menu will switch between ON and OFF in the menu, with ON turning on the message display and OFF switching off the message display.

The following message for Lead Fault will be shown with affected channels:

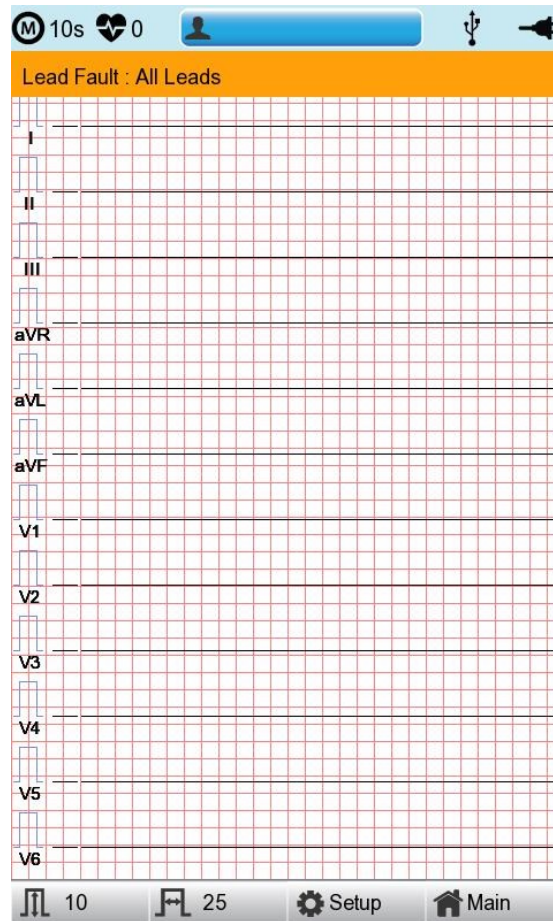

Note

- If 'RA' Lead becomes Fault, the wave types of all Leads will not be indicated.
- If 'LA' Lead becomes Fault, the wave types of I and V1-V6 Leads will not be indicated.
- If 'RA' Lead becomes Fault, Lead Fault message might not be shown, and the wave types of all Leads might be indicated.
- If 'LL' Lead becomes Fault, the wave type of II and V1-V6 Leads will not be indicated.
- If a Lead Fault occurs during monitoring or recording, a buzzer alarm will sound, and the message box will pop up.
- No pacemaker signal may be detected. Additionally, if a Lead Fault occurs, please re-measure the EKG as it could have affected the measurement by the device.

11-4-6) Pacemaker signal printing

In case of using the pacemaker signals, you can choose whether to print out the location of the pacemaker when monitoring or recording.

You can select ON or OFF by clicking the 'Pacemaker' item. When it is on, the location of the pacemaker will be printed out, while when it is off, it will not be printed out.

Note
<ul style="list-style-type: none">- It is recommended to set the pacemaker off for normal use and only when the patient uses a pacemaker, set it on.- When having a Lead Fault, the Pacemaker signals may not be detected.

11-4-7) QRS Sound Setup

In this menu, users can set the device to ring an alarm sound when a QRS beat has generated while it is in waiting mode. Users can either set the alarm ON or OFF by selecting the menu with ON turning on and OFF turning off the alarm sound.

Note
No sound will ring while printing even when the QRS sound is set to ON.

11-4-8) Method of Leads Place

'Leads Place' menu shows how to connect electrodes on the graphic display. Focusing on and selecting 'Leads Place' menu will bring the screen shown below. At that time, enter the screen-touch, rotary or [ESC] key; and then the 'how to connect electrodes' screen will disappear while going back to the 'ECG Setup' setup window.

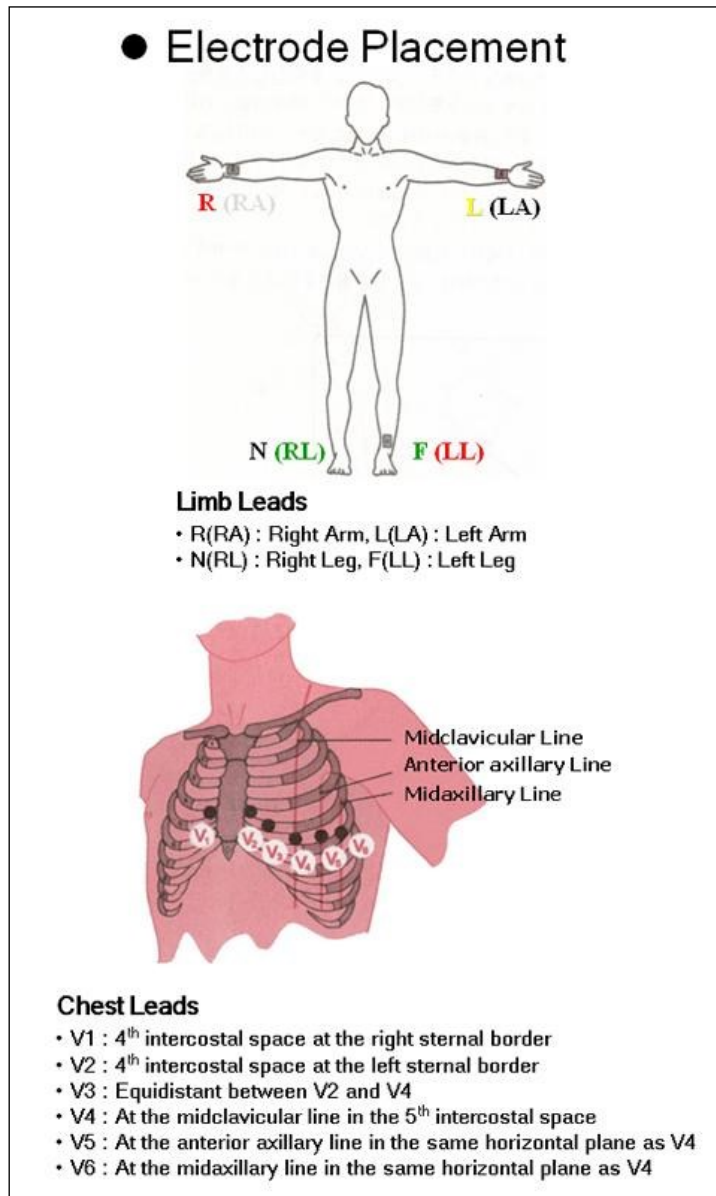

11-4-9) Demo Mode Setting

This menu puts Cardio7 in demo mode. When it is set to ON, 60bpm Sinus Normal Rhythm signal will be displayed on the device and [DEMO] sign will appear on the upper part of the LCD screen. Users can test rhythm, diagnostic, copy printing functions as well as PC communication and other miscellaneous functions in Cardio7.

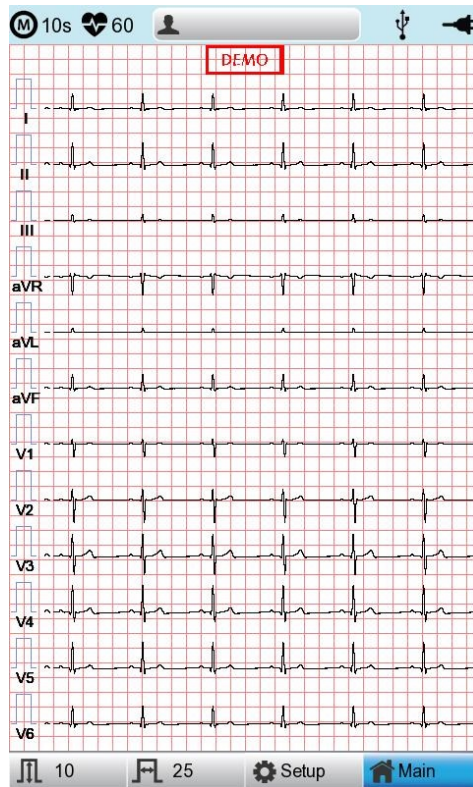

11-4-10) Lead Sequence Setting

In this menu, users can set the display formats for the lead sequence. Users can either set the Standard or the Cabrera by selecting the menu.

- Standard : The limb leads are indicated: I, II, III, aVR, aVL, aVF
- Cabrera : The limb leads are indicated: aVL, I, -aVR, II, aVF, III

11-5) Record Setup

When selecting the 'Record' menu at the left side of the Setup page, the record setup page will show up at the right side.

Record Setup menu consists of the [AUTO] key on the control panel setup item and auto diagnosis setup item.

11-5-1) 'AUTO' key setting

When the 'Store' menu has the focus, click it to set up 'Yes' or 'No'.

When 'Yes' is selected, you can operate the ECG test by pressing the [AUTO] key on the control panel and the ECG data will be automatically saved, but when 'No' is selected, the ECG data will not be saved. (Default: Yes)



When selecting the 'Export' menu, a small menu window as below will appear and it will disappear when selecting one of None, Server, USB.

If it is 'None,' ECG data will not be externally transferred; if is 'USB,' ECG data will be automatically saved to the external USB memory. In addition, if it is set up as 'Server,' data will be automatically transferred to PC Server IP among Network options. (Default: None)

Note
<p>When you remove the external device after sending to USB Memory, you should click icon  that is correct to each device.</p> <p>On top of the main screen and remove the device. Otherwise data can be damaged.</p>

11-5-2) Analysis Setup

Diagnosis setting

Set the Automatic Diagnosis level of the 10-second recording.

off : the content of diagnosis will not be printed out

Standard level: Provides only serious diagnoses with the diagnostic criteria value is raised.

Professional level: Various diagnoses are provided according to the standard diagnosis criteria.

ST Level setting

Set the ST Segment diagnosis during automatic diagnosis on 10-second recording.

AUTO: The J Point related to ST Level is automatically set.

60msec: J Point is set to 60msec point.

80msec: The J Point is set to the 80msec point.

V Channel setting

'V Change' menu is used to set up the V3 ~ V6 on the printing paper when diagnosing children in which the location of V3 ~ V6 electrodes need to be changed from left to right.

Basically, the 'V Change' is set as 'None' and when you click this menu, a 'Leads Change' POP-UP window will show up as below. Each time you select the V3R, V4R, V5R or V6R, it will be on or off. When one is selected, the letter R will be seen at the end of the chosen channel (V3 → V3R), otherwise it will not.



11-5-3) Long Time Setting

Duration of Arrhythmia and HRV recording can be set up. It can be selected as 1, 3, 5 or 10 min.

Note

- For Arrhythmia and HRV, only 3min, 5min or 10 min are available.
- Upon output of Arrhythmia and HRV, ECG with pre-setup duration will be printed out by one choice of Lead a line at 20-second interval.
- Output will be indicated in increments of 5 mm/mV for gain and in increments of 12.5 mm/sec for speed.

11-5-4) Arrhythmia Setting

When performing Long Time recording, arrhythmia printout options can be configured. If 'Arrhythmia' option is selected as ON, printout will be performed; if OFF, it will not be performed.

11-5-5) HRV Setting

When performing Long Time recording, HRV printout options can be configured. If 'HRV' option is selected as ON, printout will be performed; if OFF, it will not be performed.

Warning

Do not touch the patient cable or the equipment when using a cardiac defibrillator.

Warning

Please make sure the connector does not touch the conductive parts or the ground when connecting the electrodes or the patient cable.

Warning

The ECG patient cable provided is supposed to use for ECG measuring. Do not use it to measure breathing.

Caution

Use the electrodes same as the provided ones or with biocompatibility certificate authorized by the international standard.

Caution

When the patient, who had an operation to have a heart assist device, uses Cardio7, it should be done under the supervision of a health care professional.

11-6) Service Setup

If 'Service' menu on the left of the Setup screen is selected, the other Setup screen related to 'User Security Set' and 'Manufacture Set' will appear.

At 'User Security Set' setup, it is possible to change Factory Setting and User Password.

At 'Manufacture Set' setup, it is possible to change Upgrade and Device Options: please contact the Bionet Service Center.

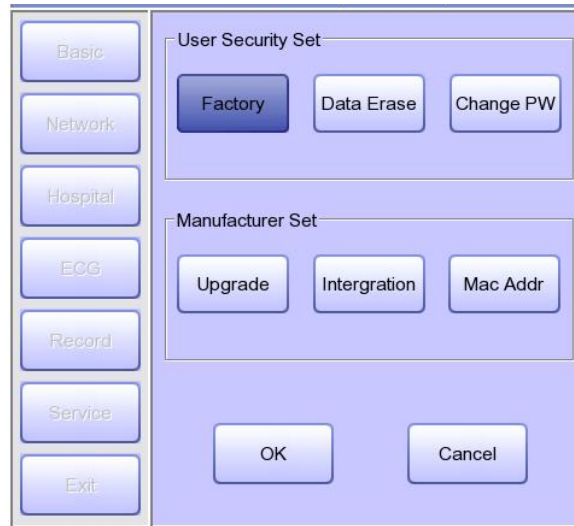

11-6-1) Factory (Reset Settings)

In order to reset to factory conditions, press the [Factory] button and enter the Password. Reset will proceed, with the message below appearing on the LCD screen for 1 second.

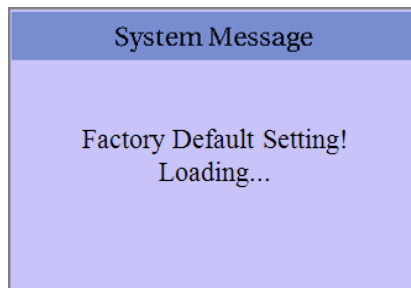

The initialized values are as follows.

Contents	Setting Value
Gain	10mm/mV
Speed	25mm/s
Start Option	Main
Unit	Height: cm, Weight: kg
Date Type	YYYY-MM-DD
Patient Info (File)	Delete
Device Name	Cardio7

Net Device	Wired
Configure	Manually
Device IP	192.168.30.224
Subnet Mask	255.255.255.0
Gate way	192.168.30.1
BMS Server	0.0.0.0
Hospital	blank
Doctor	blank
Preview	On
Quick Print	Off
Lead Fault	On
Pacemaker	Off
QRS sound	Off
Demo	Off
Mon Form	12ch
Mon Size	Continue
Grid	Off
Rec Form	3ch + 3
Paper Size	Report
Print Line	Normal
Beat Form	Off
Rhythm	II, V1, V5
Base Filter	0.2Hz
AC Filter	For ENG and KOR language, '60Hz' For other languages, '50Hz'
Low Pass Filter	150Hz
EMG Filter	Off
ECG Store	Yes
Print Out	Yes

Export	None
Diagnosis	Professional
ST Level	Auto
V Channel	None
Long Time	Off
Arrhythmia	Off
HRV	Off
Target	PC
Method	Manual
Format	EKG
Delete	Yes
JPEG Size	1024 x 768
Pressure	760mmHg
Humidity	70%
Temp	25°C
Syringe	3000cc
Patient information	initialized

Note

Even though the system is reset, the 'User password' is not initialized.
--

11-6-2) Data Erase

All data in Files and Worklist will be deleted.

For the data erasure function, a password must be entered.

11-6-3) Change PW

User Password can be configured. User Password is the number entered for Factory and Data Erase. The password should be a 4-digit number.

Note

Contact the Bionet service center when you forget your password.
--

Part II. Using Spirometer

Chapter 3. How to Install

1) Connecting Spirometer Handle

Spirometer handle should be connected to the main body by plugging in the end of its cable to USB port in the main body (shown below)

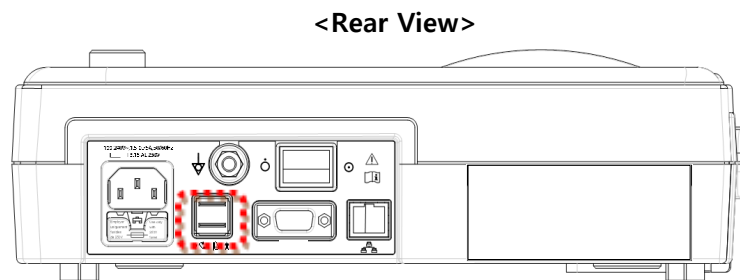

- (1) Connect the spiro handle with the equipment powered off.
- (2) Turn on the power switch of the equipment.

1-1) Verifying Spirometer Handle's status

Spirometer handle is ready to operational status when the green lamp where is on the handle is on.

2) Installing a Mouthpiece

To start the test, anchor the disposable mouthpiece to the top of the spiro handle. First, press the Front Cover Lock Switch on left top corner of spirometer handle to open the semicircular Front Cover, and accurately fit the mouthpiece on the inserting slot made on the open side. Press the Front Cover with a little force to close it. The tube of the mouthpiece should be long on the front side and short on the rear side of the spiro handle if the mouthpiece is correctly anchored.



(1) Press the Front Cover Lock Switch on the top left corner of spirometer handle and open the Front Cover in semi-circle shape.



2) Put the mouthpiece on the inserting lot made on the open side.



(3) Press the Front Cover with a little force to close it.

Caution
<ul style="list-style-type: none">● A mouthpiece is for single use only.● Do not close the cover while pressing the lock switch.

Chapter 4. How to Use

1) Getting Started

Turn on the switch on the main body and locate the selection box in the Spirometer area by turning the rotary key on the initial screen. Afterward, press the rotary key or touch the selection box in the Spirometer area to shift to Spirometer measurement mode.

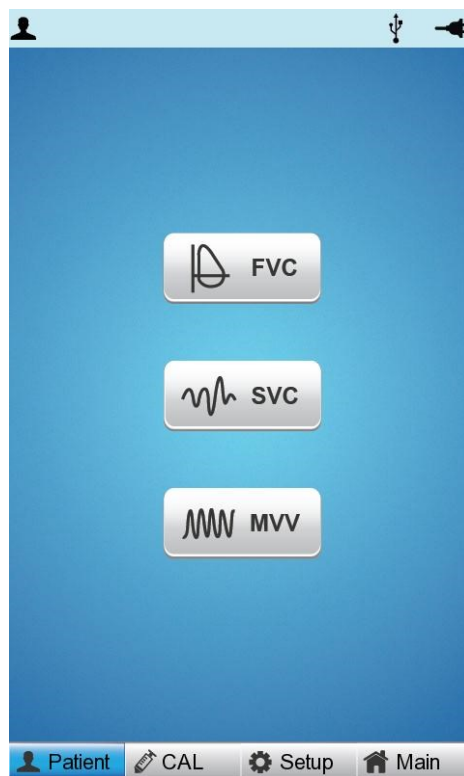

<Menu screen of Spirometer>

To activate the function of the selected item, turn the rotary key on the menu screen of the spirometer above and locate the selection box in the desired item area; afterward, press the rotary key or touch the desired item area.

All functions are selected and activated when the items on the screen are touched or the button/rotary key on the operation panel is used.

2) Entry of Patient Information

The personal information of the patient must be entered before the pulmonary function test begins. Specifically, items such as "Age", "Gender", "Height" and "Race", which are indicated as "*" in their input fields, must be entered because they are essential for the diagnosis of the pulmonary function.

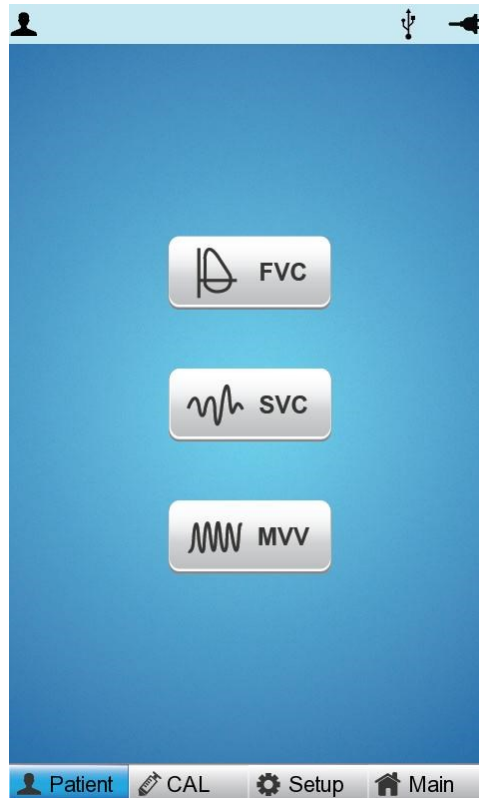

To enter the Patient ID and other information, locate the shaded block in "Patient" as the Patient ID area, and then press the rotary key or touch the area to shift to Patient Information Selection mode as illustrated in the figure below.

The screenshot shows a 'Patient Information' form with the following fields and values:

- ID: [Empty field]
- Name: [Empty field]
- Age: [Empty field] years
- Gender: Female
- Height: [Empty field] cm
- Weight: [Empty field] kg
- Race: Asian
- Smoke: No
- Department: [Empty field]
- Room No: [Empty field]

Buttons at the bottom: OK, Cancel, New.

〈Patient Information Selection Mode〉

To activate the Information Input mode, locate the shaded block in the desired "Patient Information" area and press the rotary key. The information can be entered by using the rotary key or touching the desired area. The Entry Mode consists of the Keyboard mode, which enables the input of both characters and numbers, and the Keypad mode, which enables the input of numbers only. The Keypad Entry mode appears if no alphanumeric characters need to be fed into the Information Entry section.

2-1) Entering ID

Enter ID value used in the hospital to classify examination result. You can enter a value made from a combination of up to 20 letters and numbers by using the rotary key or the touchscreen. If you select "ID", letter entry space that consists of alphabet and numbers appears on the screen. If you turn the rotary key to the right, cursor moves consecutively from left top to right bottom. Letters or numbers on which the cursor is placed are highlighted on the screen. If you press the rotary key or touch here, the selected letters or numbers are entered. If you place "OK" on the cursor and press the rotary key after completing entry, the ID numbers entered in advance are saved and the letter entry space disappears from the screen. If you turn the rotary key to the right, the cursor moves to "Name" entry space.

Note

- When entering an ID, it is impossible to enter special characters such as ", <, >, ?, /, *, |, ;, ₩, etc. (these invalid characters are set to be inactive)
- When entering an ID, an English keyboard will be displayed, regardless of whether there is a multi-language set-up.
- Use only plain alphabets and numbers for ID. If you enter an ID in Latin extended characters or Russian, an error may occur when you transfer files with the IDs to a PC or USB memory.

**<Keyboard>****2-2) Entering Name**

Enter the patient name in the same way as entering the ID.

2-3) Entering Age

Enter the patient's age directly.

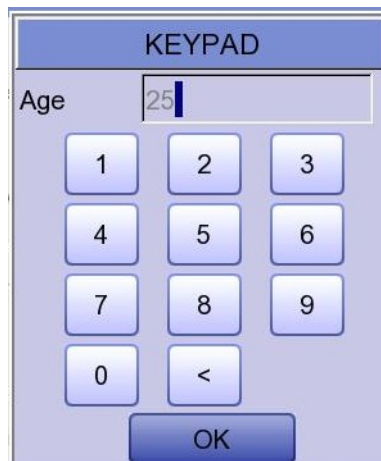
**<Keypad>**

2-4) Entering Gender

Touch the input field of Gender to select Male or Female.

2-5) Entering Height

Enter the patient height in the same way as entering the age.

If the Height Unit is set to inches in System General Setup, enter the height in *ft* and *inches*.

2-6) Entering Weight

Enter the patient weight in the same way as entering the age.

2-7) Entering Race

Enter the race of the patient. There are 3 registered races: Asian, White, and Black.

Touch the input field of Race to select the race type.

2-8) Entering Smoke

Enter whether the patient smokes or not.

Note
Patient information will be initialized if the language preference is changed at system set-up.

3) Forced Vital Capacity (FVC) Test

3-1) FVC Test (Base Test)

Select [FVC] by turning the rotary key or touch. At this time, the patient information must be entered beforehand to ensure diagnosis based on the measured results.

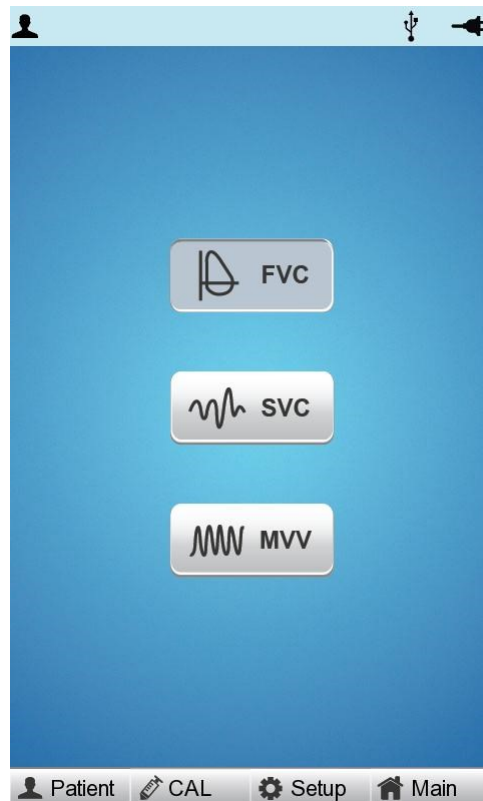

When you select the [FVC] menu, the screen shifts to the FVC Test screen following the test preparation process as shown in the figure below.

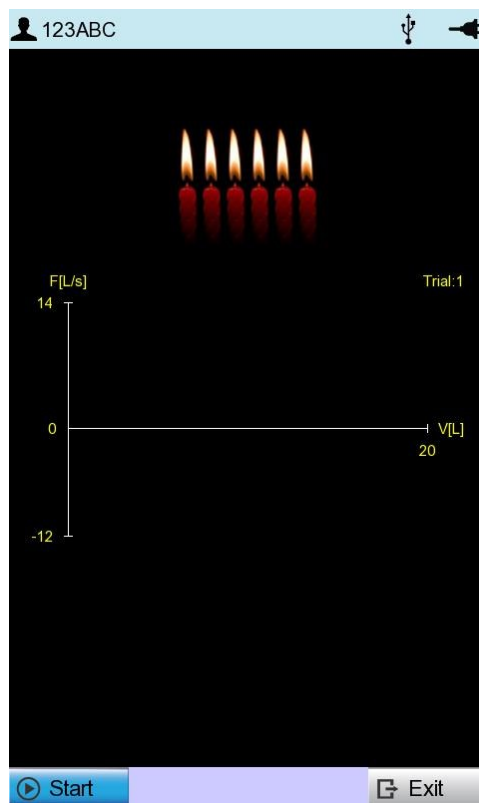

A message appears as shown below if the Spirometer handle is not connected or power is turned off on the handle. This message is also displayed in the same way during the SVC Test and MVV Test. At this time, touch [Exit] by hand or press it using the rotary key to go to the main menu and check the handle before resuming the test.

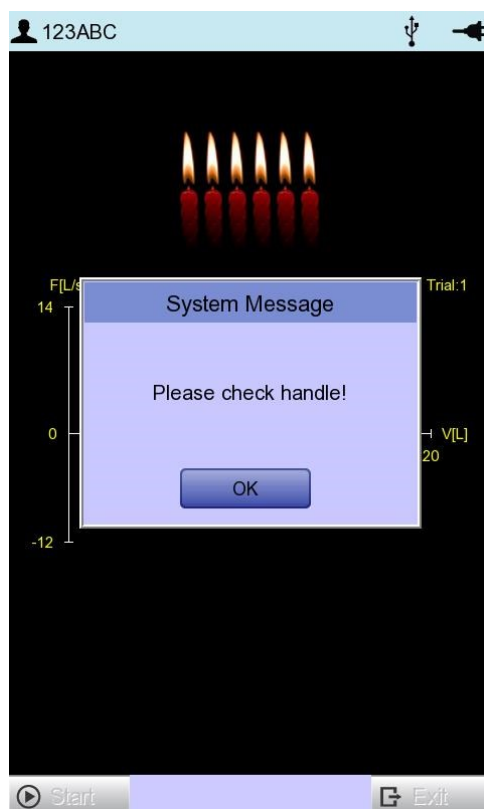

The screen below appears, and FVC test measurement is ready if the Spirometer handle is connected normally.

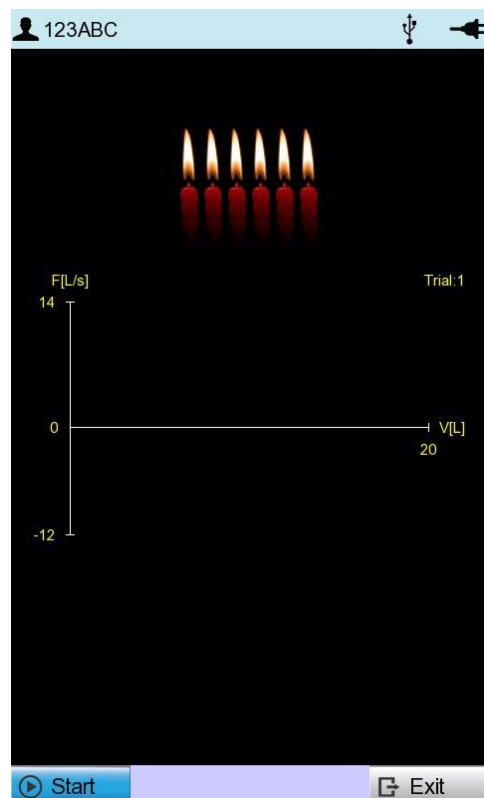

Have the patient hold the spiro handle and place it in front of his or her mouth, and touch [Start]. To ensure accuracy, measurement must be carried out exactly according to the procedure described below.

< **How to Breathe during FVC Test** >



1) Breathe twice or more as usual.

Prepare for the measurement while breathing as usual. This is recommended to achieve accurate test results.



2) Inhale as much as possible. (TLC level)

Breathe in as much as you can regardless of the speed. (Instruct the patient to inhale as much as he or she can.)



3) Exhale as fast and much as possible. (Forced expiration)

Exhale as fast as possible and also as much as possible. Try to blow off all 6 candles in the candlelight animation. 1 candle means 1 second.



4) Inhale fast and much as possible. (Forced inspiration)

Now that you are running out of breath, you are naturally panting for breath, but you should try your best to inhale as much as possible, not to inhale in order to overcome your shortness of breath.

5) Touch [Stop] to end the test.

Note

- In principle, the patient should be in standing position. The test can be done in a sitting position as well, but the more effortful lung capacity are acquired in standing position. Pregnant women, obese people and pediatric can sit down to take the test.
- Raise your chin upwards by about 15 degrees and keep it all the way: avoid bending your neck or chin. Do not bend or twist your back, and keep the original posture until you're done with the test.

If the patient has any difficulties with breathing while performing aforementioned tasks, change the procedures as following.

- 1) Take normal breath at least once and then,
- 2) Inhale as much as possible,
- 3) Exhale as much as possible,
- 4) Inhale again.
- 5) Press the [Stop] button.

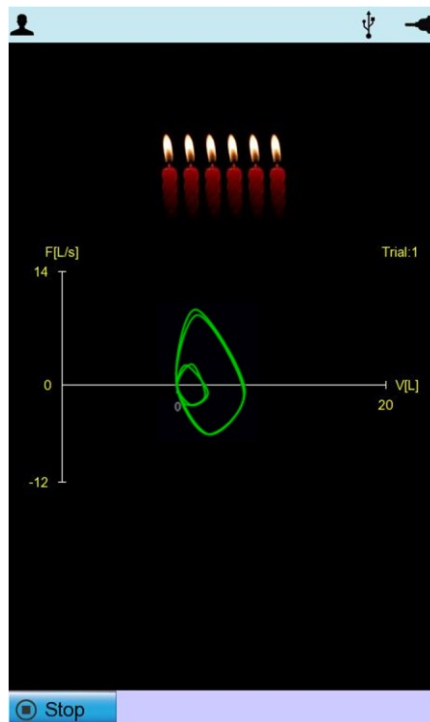

If you take breaths in above-mentioned orders, a graph showing the result of normal breaths appears in small size. If you go ahead with step 2 to 4, a big graph is drawn in the screen. If the user presses the button, one round of measurement is finished. The shape of this graph is not

important, since the graph drawn during the measurement just indicates the fact that the patient is breathing, and does not correspond with actual breathing data.

3-2) Result screen

Press [Stop] button by using rotary key or touchscreen to signal the machine that measurement is finished. After pressing the button, the following screen showing the result of the measurement will appear.



<Result screen menu>

● **New:** Start a new test.

- Touch [New] to start a new test.

If you touch [New], a message asking whether to accept the previous test result appears. Here, [Yes] increases the number of tests and [No] ignores the previous result.

In a new exam screen, touch [Start].



● **Print** : Print out the test result.

- It prints the measurement result in a graph and a chart.

Note

Do not attempt to attach or detach a USB device while the printer is working as it may cause the printer module to rattle.

● **VT** : The measured result will be presented as a VT graph.

- The measured result will be presented as a Volume & Time graph as shown below. Press 'FV' again by using the rotary switch or touch to see it in Flow & Volume graph.



● Select BEST measurement

- At the end of the measurement, it shows the BEST measurement number selected in the automatic diagnosis. The selection criteria for Best measurement are obtained at the maximum value of the FVC+FEV1. If it needs to change the automatically selected Best measurement, it can select a different measurement PEF number with a touch.

● Exit : End the test and return to the Spiro main screen.

- If you press "Yes" after finishing all measurements, the machine will show the main screen.

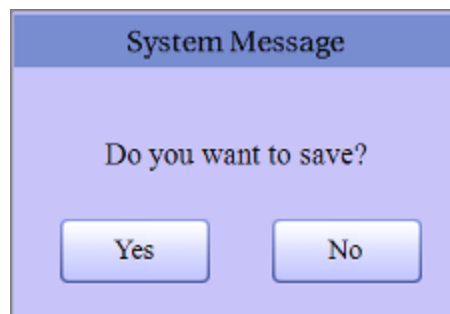

At this time, select "Yes" to save the data, or "No" to cancel.

◆ If "Yes" is selected

- (1) A message appears, requiring the entry of Patient ID; if the Patient ID was not entered before saving the data, the Patient Information Entry window would be displayed.

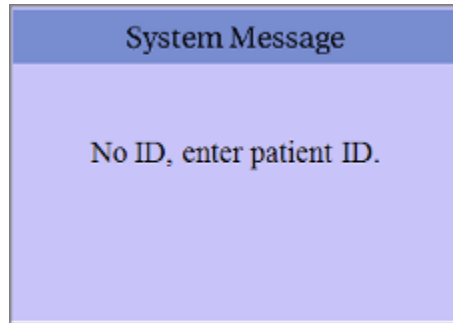

- (2) The data-saving process starts if Patient ID is entered

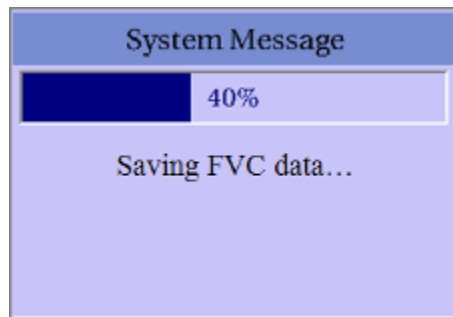

- (3) Once the saving process is complete, a message box asking whether the patient information is to be deleted appears.

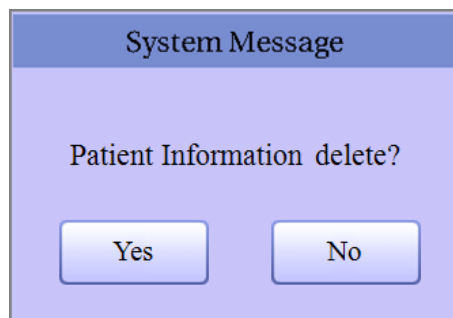

- (4) The main screen of Spiro is displayed.

Note

The following messages will appear when the memory is full.

- Message appeared after saving the last data

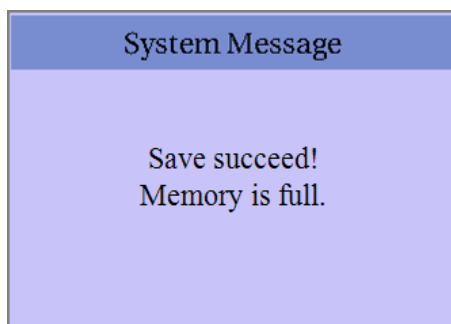

- Message appeared when selecting to save data again after saving all data

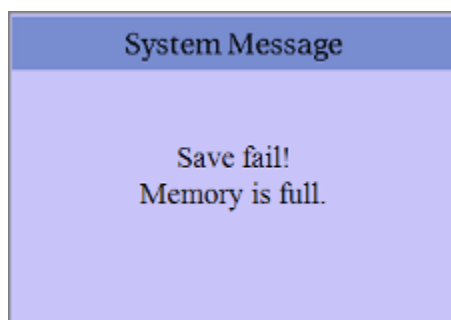

- FVC Test Print Form

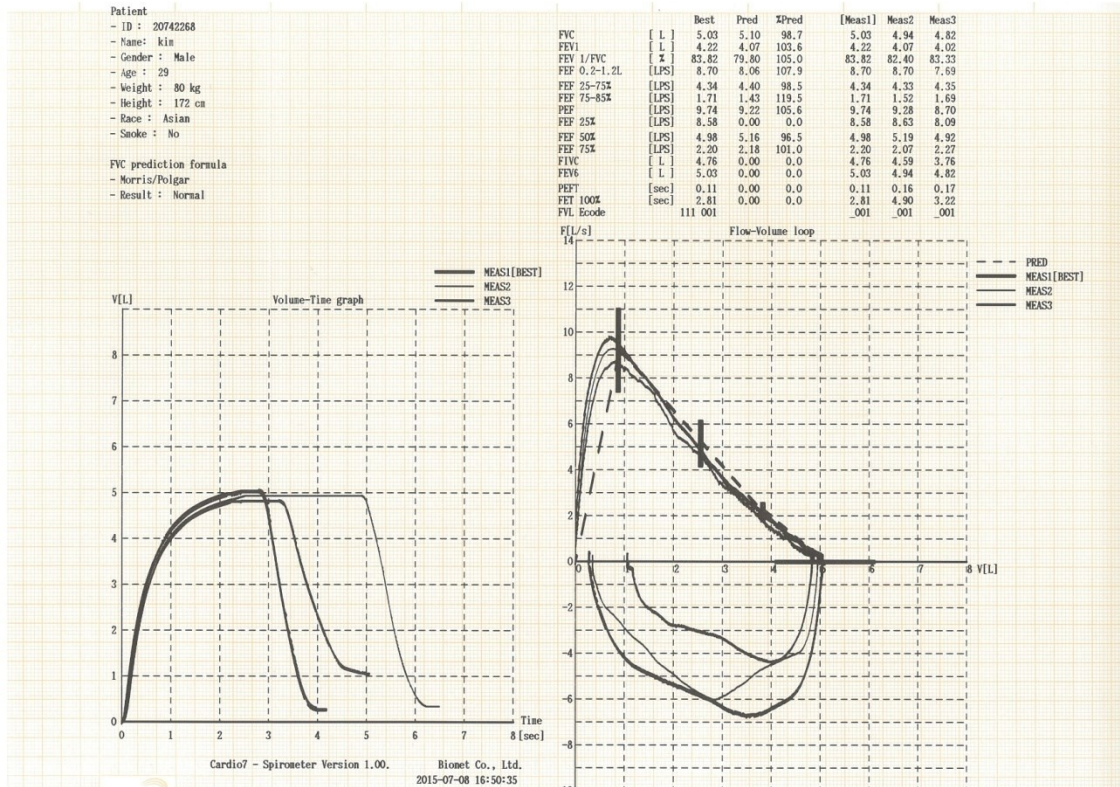

Note

If a USB device is installed or detached during printout, the printer module may rattle, so please refrain from removing and installing it during printout.

3-3) FVC+(PRE-POST Bronchodilator Comparison) Test

- (1) "FVC+" enables the comparison of the results of the test performed twice before and after medicine is administered. The procedure is as follows: First, conduct the measurement according to the FVC test method, and then save the data.
- (2) Once the data is saved, go to the Data List menu to check the data indicated as "FVC" based on the entered ID type of the patient.

No	ID	Name	Age	Date	Study
1	ddfd1		0	19700101	ECG
2	abcdefg		0	19700101	FVC
3	12345678...		0	19700101	SVC
4	dog		0	19700101	MVV
5	abcdefg		0	20000101	FVC+
6	abcdefg		0	20150101	MVV
7	111	aaa	0	20140101	MVV
8	hhgtggug		46	19700101	ECG
9	ttftyh		0	19700101	ECG
10	help me	RYU	0	19700101	ECG
11	qwe	45678	18	20150101	FVC
12	qwe	45678	18	20150101	SVC
13	7hh		0	20150101	MVV
14	yhh		0	20150101	ECG
15	hgx		0	19700101	FVC
16			0		SVC
17	hhgtggug		46		ECG
18			0		SVC
19	111	aaa	0	20140101	MVV
20	7hh		0	20150101	MVV
21	abcdefg		0	19700101	FVC
22	abcdefg		0	20000101	MVV
23	abcdefg		0	20150101	MVV
24	help me	RYU	0		ECG

Save the results of the first test prior to the administration of medicine.

Save the results of the second test after the administration of medicine.

- (3) Select the saved FVC data of the patient from the Post-Medication Test List, and then select Spiro from the Main manu.
- (4) Selecting Spiro from the Main menu leads back to the Spirometer Main menu; at that time, switch from FVC Test menu to 'FVC(P)' can be confirmed. Switch to 'FVC(P)' must be confirmed before conducting test.

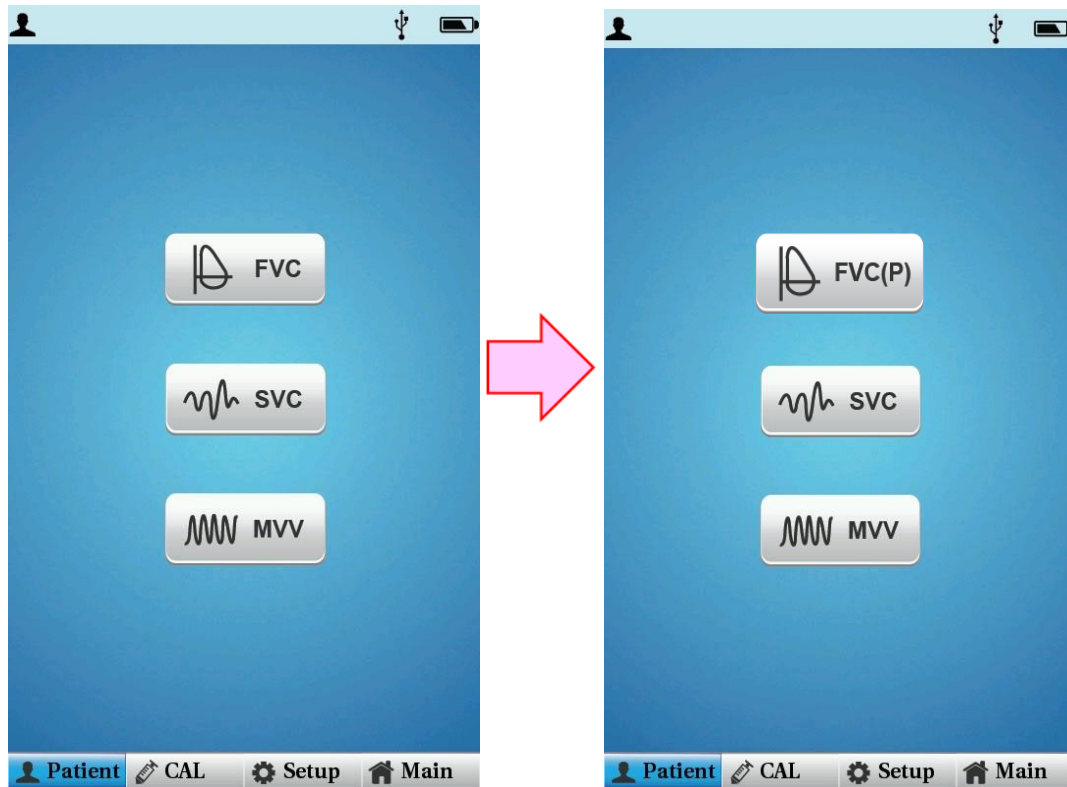

(5) The test can be conducted in the same way as FVC by selecting "FVC+" menu.

(6) The parameters and graphs of pre-administration (Base) and post-administration (Post) can be compared if the results of measurement are printed.

(7) You can see "FVC+" displayed on the data list menu if you press the "Exit" button and save the data. "FVC+" displays the saved data showing the results of the test conducted twice, before and after the administration of medicine.

Note

- If test needs to be performed twice, i.e. before and after medication, set up as [Setup → SPIRO → FVC Post → On] before use.
- Select the Patient Information Entry mode followed by the "New" button in the Patient Information Entry window to go back to the initial test screen if you want to test a new patient with "FVC(p)" displayed on the main screen of the Spirometer. At this time, the previous patient information can be initialized only if you select "New" from "Patient Information" and enter the patient information.

- FVC+ Test Print Form

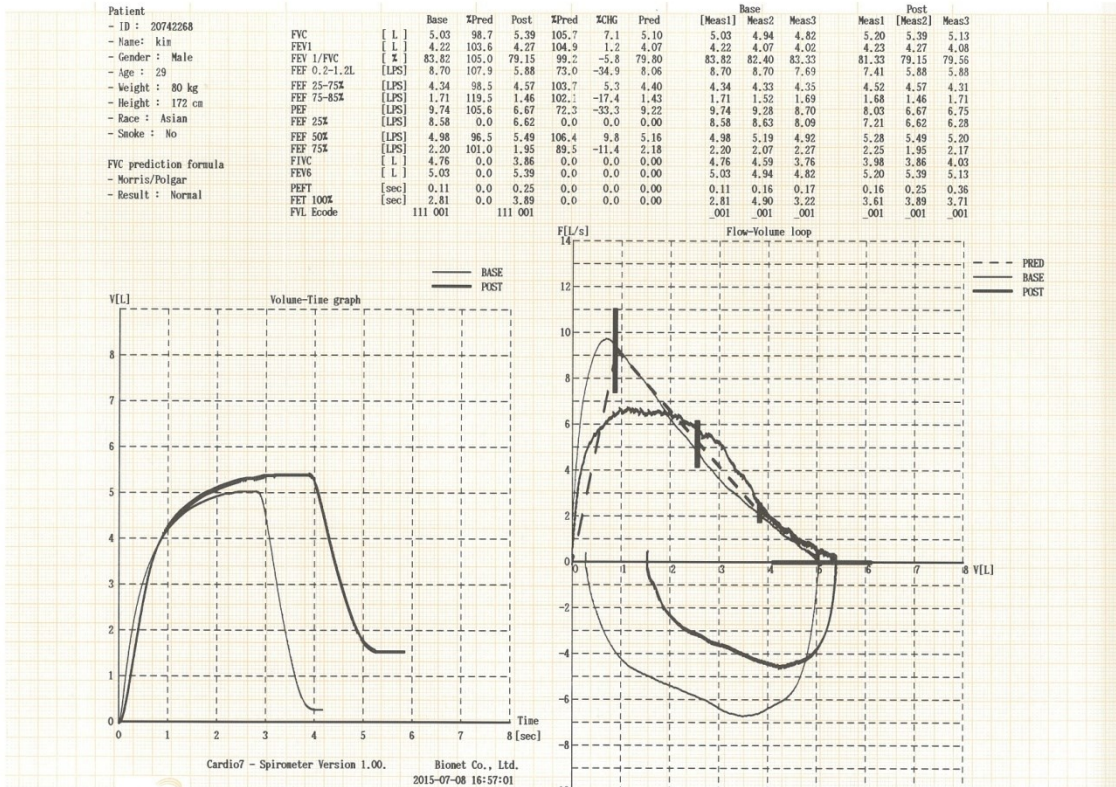

4) Slow Vital Capacity (SVC) Test

Touch [SVC] in the Spiro main screen to start SVC testing.

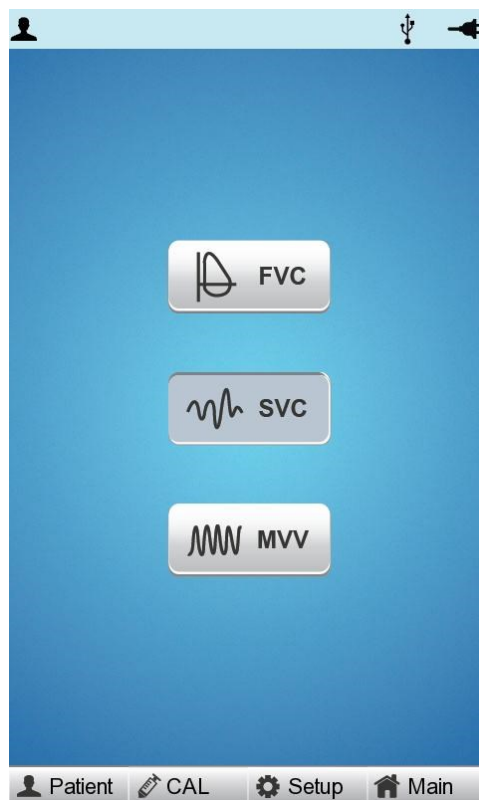

Have the patient hold the spiro handle and place it in front of his or her mouth, and touch [Start].

When the equipment sounds a beep, have the patient bite the mouthpiece and start the test.

Follow the procedure below to achieve accurate test result.

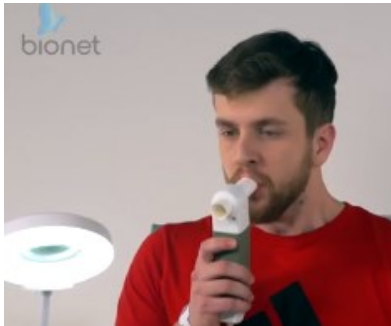
< How to Breathe during SVC Test >**1) Breathe as usual for at least four times**

You will hear a click if breathing is detected as usual for more than four times.

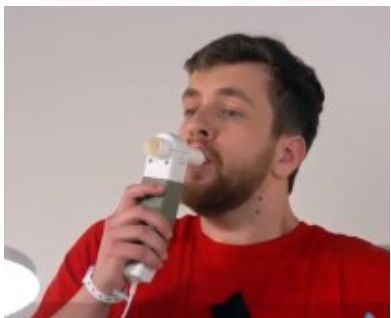
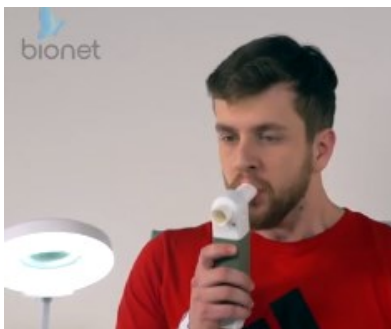
**3) Exhale slowly as much as possible (RV level).****3) Inhale slowly as much as possible (TLC level).****4) Return to normal breathing.**

If you breathe in the above order, the breathing speed is shown on the graph (V-T). Breathing as usual is shown smaller and a bigger graph is shown on the screen if you have followed the order from 2) to 3).

A positive velocity (F[L/s]) means exhaling and a negative velocity means inhaling.

Touch [Stop] after the test. A (V-T) graph showing the changes in the lung capacity over time appears.

Speed in the positive side(F[L/s]) of the screen indicates exhalation and that in the negative side inhalation. If you press [ESC] key while you are taking measurement, the machine would stop taking the measurement, and return to spirometer initial menu screen.

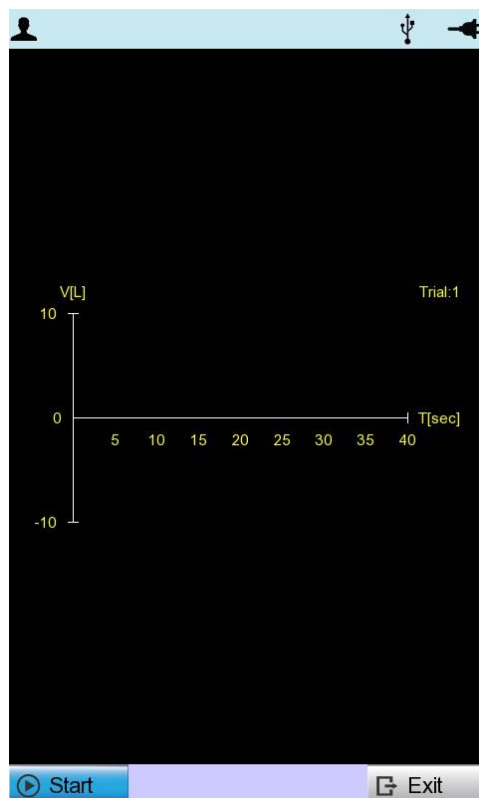

Once the measurement is finished, a graph(V-T) showing change in volume of lungs to passage of time is drawn like the screen shown below.

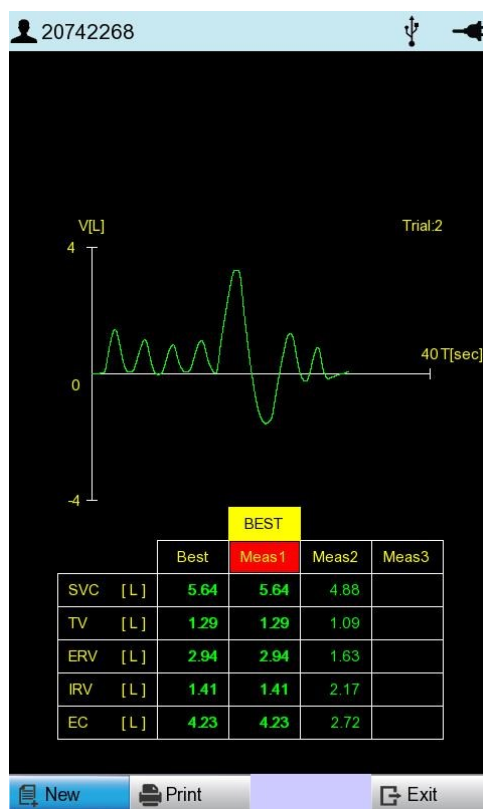

The best choice of SVC for automatic diagnosis is determined by the maximum value of SVC. The 'Best', 'New', 'Print' and 'Exit' menus are used the same way as for FVC test measurements.

- SVC Test Print Form

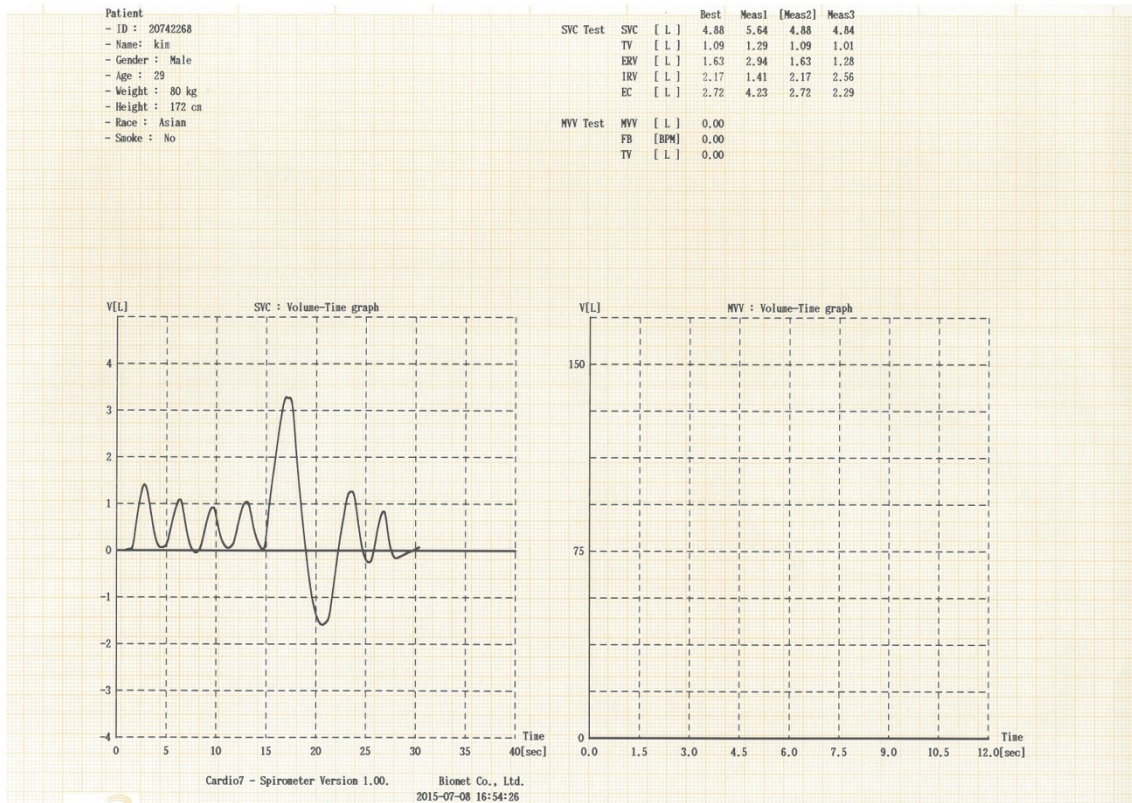

5) MVV(Maximum Voluntary Ventilation) Test

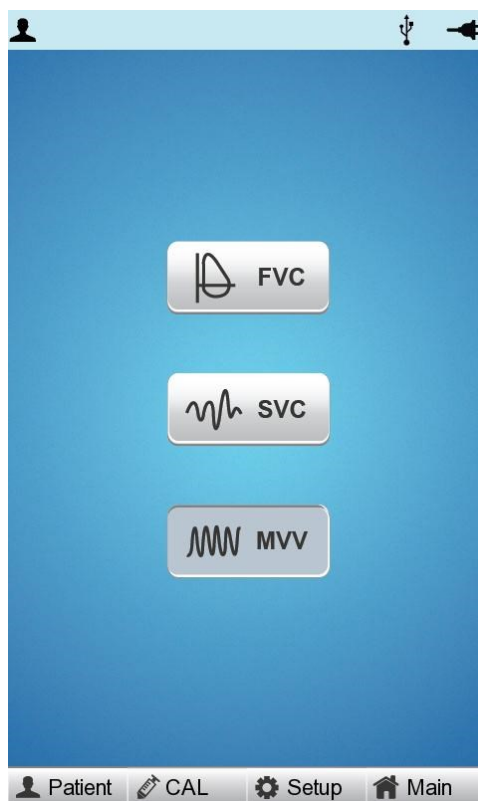

Touch [MVV] in the Spiro main screen to start MVV testing.

Touch [Start] in the screen shown below to start a test.

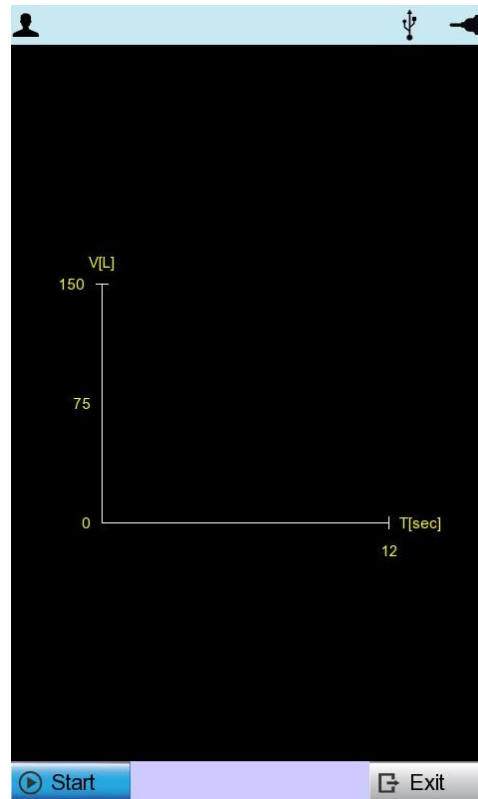

Have the patient hold the spiro handle and place it in front of his or her mouth, and touch [Start]. When the equipment sounds a beep, have the patient bite the mouthpiece and start the test. Follow the procedure below to achieve accurate test result.

< How to Breathe during MVV Test >

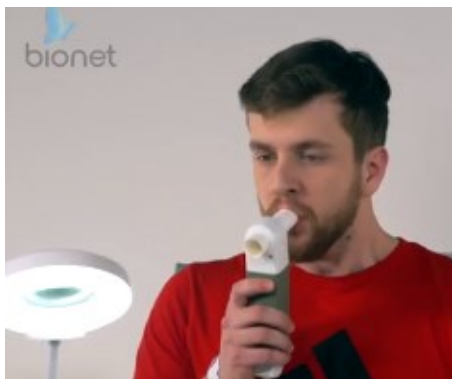

- 1) **Start a new test.**
- 2) **Breathe as fast and much as possible. (MVV)**
- 3) **When the set time (TMVV) passes, the test ends and the result is displayed on the screen. (TMVV is set to 12 seconds.)**
- 4) **Return to the normal breathing.**

If the patient performs "MVV" test following the above orders, Volume-Time graph would be drawn on the screen. The volume shown here is the result of adding amounts of inhaled and exhaled air.

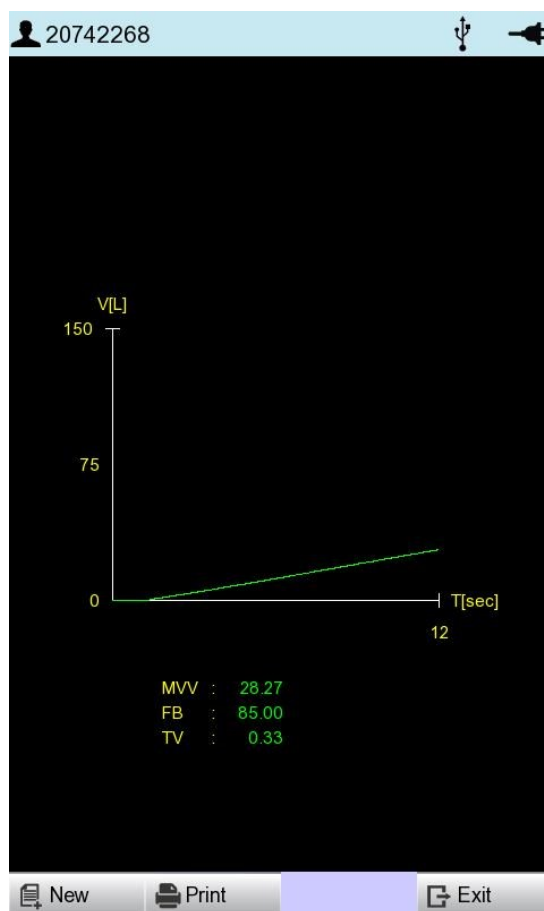

When the set time (TMVV) - 12 seconds - passes, the test ends and the result is displayed on the screen. MVV, respiratory cycle (FB), and total respiratory capacity (TV) are calculated and displayed at the top of the screen. Touch [Stop] to finish during the test. You are moved to the initial MVV test screen.

New, Print, Network, Auto, and Exit menus in the same way as in the FVC test.

- MVV Test Print Form

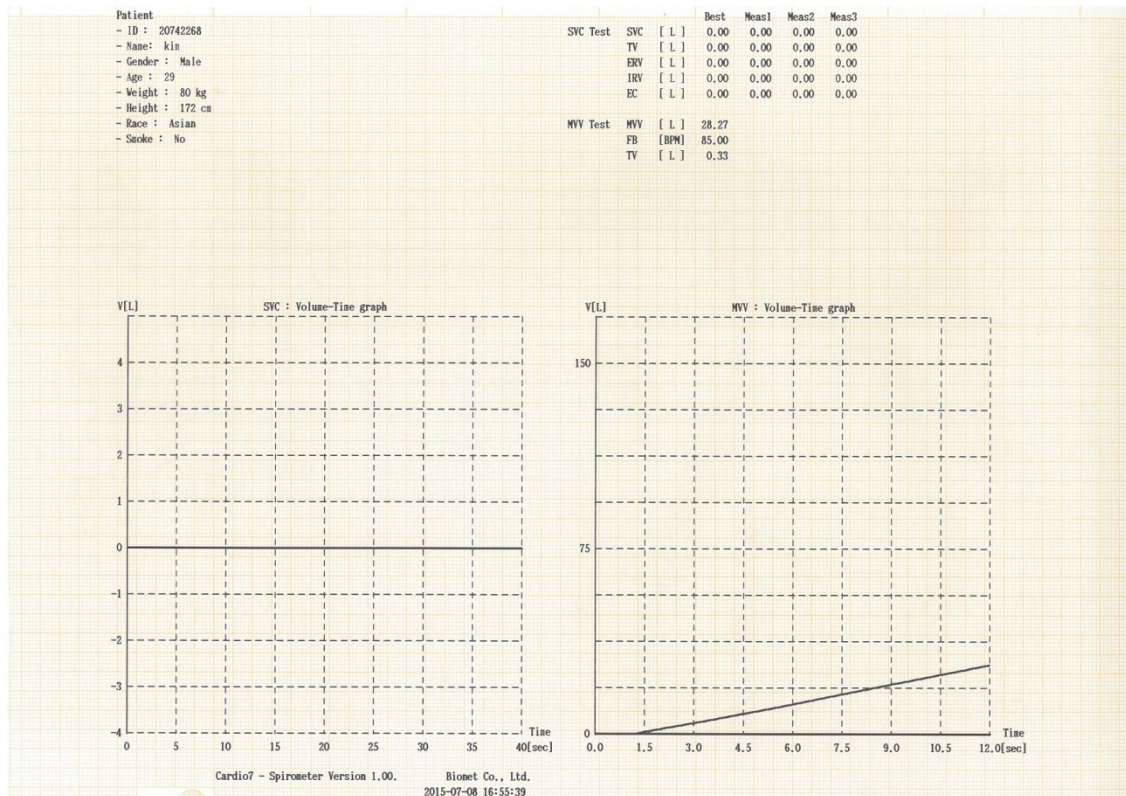

6) Calibration

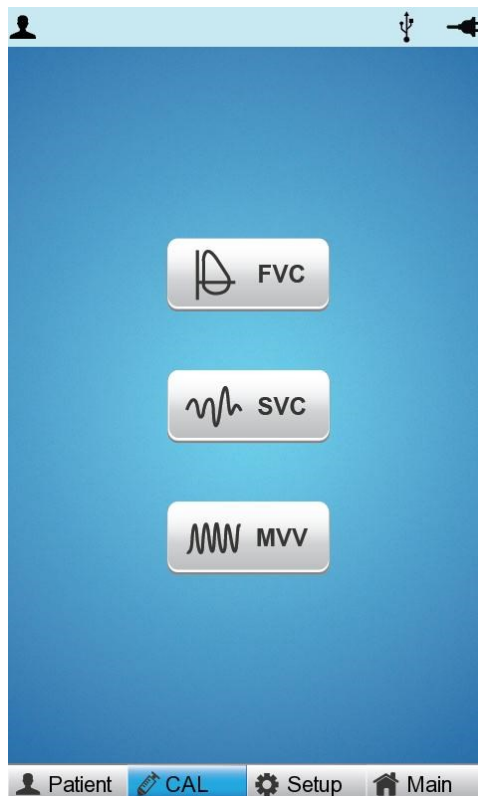

Select [CAL] from the sub-menu and press the Rotary key, or tab to the 'CAL' field to see the Calibration Main menu screen as below.

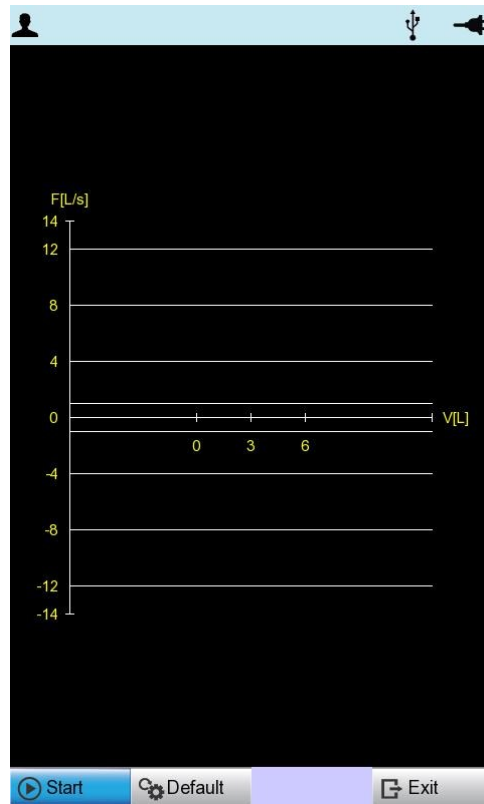

Calibration should be conducted in the following order: Violation of order might cause error in measurement.

- 1) Connect the spiro handle to the equipment.
- 2) Connect the mouthpiece installed in the spirometer handle to mouth of syringe.
Insert it tightly to prevent any leakages.
- 3) Press [Start] button. If the machine is ready for the calibration, it beeps.
- 4) Move syringe handle back and forth ten times each.
Make sure to move the handle after you hear the machine beep.
- 5) Decide whether to apply the calibrated setting to the device.

6-1) Calibration

When you are ready, touch [Start] to start calibration. The screen below appears if the syringe handle is moved back and forth. To ensure accurate correction, move the handle only after a beeping sound is heard.

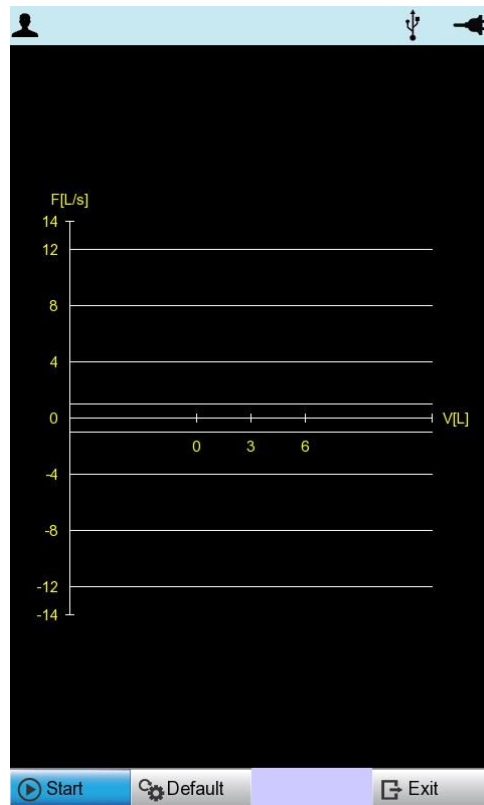

A graph representing Flow and Volume is drawn according to the movement of the syringe. After you move the syringe back and forth 5 times each, volume measuring results and error (%) are shown on the screen as below. If there is no click every time you move the syringe, touch [Exit] to return to the initial Calibration menu and start again.

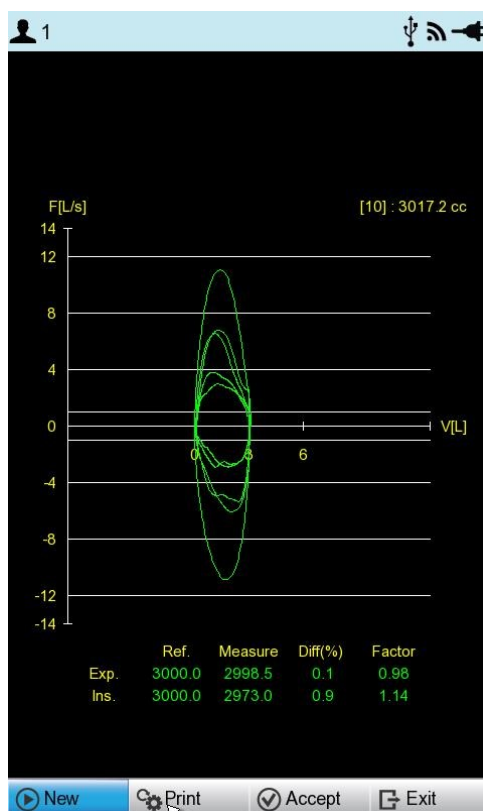

Touch [Print] to print out the Calibration results.

Touch [Accept] to apply the Calibration results to the equipment.

Touch [Exit] to finish Calibration and return to the top menu.

Note

- Bionet recommends quarterly calibration of spirometer measuring device. Be sure to perform calibration when changes in temperature and air pressure are significant.
- Repeat the calibration until the calibration result falls within $\pm 3\%$.
- A graph of not less than ± 0.5 litres shall be drawn during syringe calibration. It is recommended to calibrate so that the graph is drawn at least once within the range of ± 4 liters, ± 8 liters, and ± 12 liters.

- Calibration Print Form

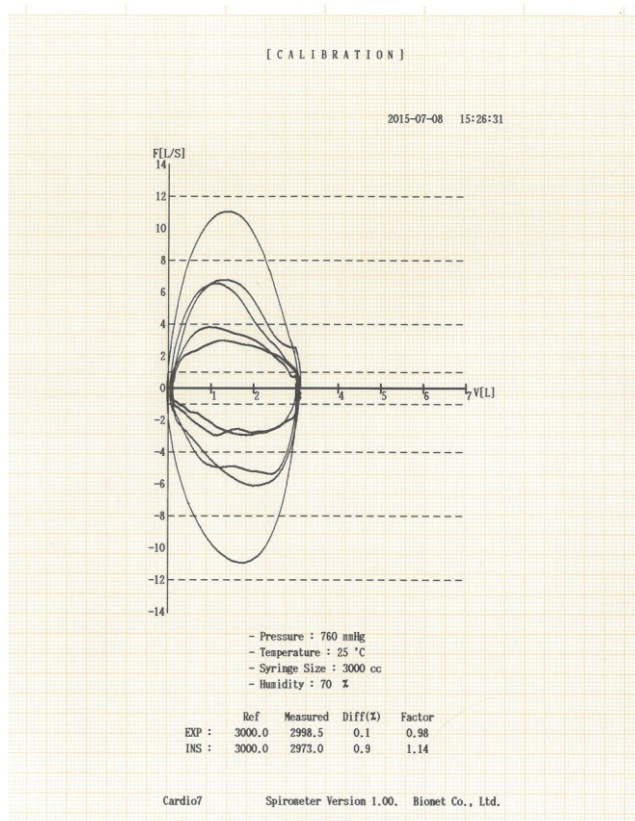

7) System Setup

System Setup menu is used to set up device-related details. From the initial screen of Spirometer, select 'SETUP' by using Rotary switch or tab.

System Setup menu consists of Basic Setup, Network Setup, Hospital Setup, Spiro Setup, Calibration Setup and Service Setup and you can change the setting at each window. The main page shows Basic Setup.

After finishing the settings, press [OK] to save the new information or press [Cancel] to cancel it. You can choose [Exit] or [ESC] button to exit from the System setup menu.

[Default] button is used to default every setting.

The screenshot shows the 'Basic' setup window. On the left is a vertical menu with buttons for 'Basic', 'Network', 'Hospital', 'SPIRO', 'CALIB', 'Service', and 'Exit'. The main area contains the following settings:

- Date: 1970 - 01 - 01 (Y-M-D)
- Time: 00 : 26 : 12 (with a 'Setting' button next to it)
- TouchScrn (button)
- Lang: ENG (button)
- Start Opt: Main (button)
- Units: cm/kg (button)
- Date Type: Y-M-D (button)
- DeviceName: [text input field]
- Device ID: [text input field]
- Bottom buttons: OK, Cancel, Default

7-1) Basic Setup

See "Chapter 2. 11-1) Basic Setup"

7-2) Network Setup

See "Chapter 2. 11-2) Network Setup"

7-3) Hospital Setup

See "Chapter 2. 11-3) Hospital Setup"

7-4) SPIRO Setup

When selecting the 'SPIRO' menu at the left side of the Setup page, Spiro Setup page will show up at the right side.

7-4-1) Formula

The 'Formula' is the diagnosis standard when executing a FVC test, therefore, after selecting the 'Formula', it is required to select one menu among 'Morris', 'Knudson', 'ECCS', 'Korea CJK' or 'Pereira'.

In addition, the contents of each Formula are explained as the below.

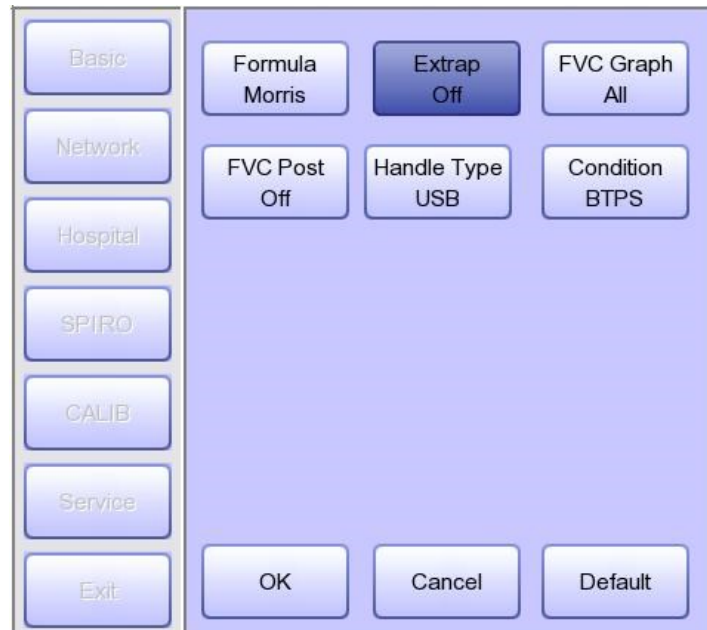

Main Use Area	Formula	Description
North America	Morris/Polgar	Widely used in North America (Default Value)
	Knudson/ITS	Widely used worldwide
Europe and Latin America	ECCS/Quanjer	Widely used in Europe
	Pereira	Widely used in Latin America
Korea	Korea CJK (Choi Jung Geun-Type)	A formula developed to suit the characteristics of Koreans

7-4-2) Extrapolation

The 'Extrapolation' function decides if the extapolated volume is printed in the FVC test.

You are able to select ON/OFF by using the touch or rotary key.

1-second forced vital capacity is calculated at the point of 1 second from the start.

If blowing with a slightly weak force at the initial point and then blowing hard,

spirometry calculates 1-second forced vital capacity at the point 1 second from the

start of weak blowing. However, it should in fact calculate at the point 1 second from the start of hard blowing. This amount of difference is called extrapolational difference.

The valid value scope of the extrapolated volume is 0.15L or within 15% of the FVC.

7-4-3) Set the 'FVC' graph format

'FVC Graph' is used to set the 'FVC' graph format. If it will be set up as 'All', all graphs of three times test are printed. And if it will be set up as 'BEST', the best one graph of three times test is printed.

Note
- Even if the FVC Graph is set to All, only the best graph is drawn when the FVC Test Count is set to 3 times.

7-4-4) The settings for the Post inspection

In case of the FVC inspection, all details of the drug test could be set. If it is set up as ON, the post inspection could be executed and if it is set up as OFF, the post inspection is not going to be executed.

Note
- Please select the patient of the FVC data in the File for the Post inspection and execute the 'Main'→ 'Spiro' menu.

7-4-5) Spirometer handle type

Set type of the Spirometer handle (USB or Serial). Cardio7 only connects to this type of Spirometer handle.

7-4-6) Condition Setting

"Condition" is used to set the air condition. If set to BTPS, the actual patient's respiration is measured, and if set to ATP, flow rate using external air such as a simulator or syringe can be measured.

7-5) Calibration Setup

When selecting the 'CALIB' menu at the left side of the Setup page, Calibration Setup page will show up at the right side.

Basic	- Pressure :	760	mmHg
Network	- Humidity :	70	%
Hospital	- Temp :	25	°C
SPIRO	- Syringe :	3000	cc

OK Cancel Default

When selecting items such as Pressure, Humidity, Temperature and Syringe Size by using Rotary switch or tabbing, the number keypad input window will appear.

When entering the appropriate value for each item in the Keypad input window, Calibration defaults are modified.

7-6) Factory (Reset Settings)

See "Chapter 2. 11-6) Service Setup"

Part III. Data & System Management

Chapter 5. File management

1) Display and function

The screenshot shows a file management interface with a table of data. Above the table, callouts 1 through 6 point to the top status bar and navigation buttons. Below the table, callouts 7 through 10 point to the bottom action buttons.

No	ID	Name	Age	Date	Study
1	ujj	ryhj	0	20150708	ECG
2	1234		0		ECG
3	234		0		ECG
4	cdee		0	20150512	MVV
5	drrg	rdvgy	0	20150512	FVC
6	ed		0	20150512	FVC
7	gjin		0	20150512	ECG
8	ujj		3	20150512	FVC
9	wrtu		0	20150512	FVC
10	1234		0		ECG
11	234		0		ECG
12	cdee		0	20150512	MVV
13	drrg	rdvgy	0	20150512	FVC
14	ed		0	20150512	FVC
15	gjin		0	20150512	ECG
16	ujj		3	20150512	FVC
17	wrtu		0	20150512	FVC
18	1234		0		ECG
19	234		0		ECG
20	cdee		0	20150512	MVV
21	drrg	rdvgy	0	20150512	FVC
22	ed		0	20150512	FVC
23	gjin		0	20150512	ECG
24	ujj		3	20150512	FVC

① Page information

For example, [1/20] means that you see the first page among total 20 pages. 1 Page contains 24 lines of Data.

If Rotary is selected, the focus will be moved to Data list.

② Button to skip to the previous page

- ③ Button to skip to the next page
- ④ Button to check the patient's information of the chosen data saved
- ⑤ Button to search the data you want
- ⑥ State of battery or AC power connection
- ⑦ Button to print out the chosen saved data
- ⑧ Button to delete the data
- ⑨ Button to set up the environment of 'File Management'
- ⑩ Button to move to other main screen from 'File Management'

At the initial file management page, the first data of the list has the focus. The focus will automatically move to the menu bar at the bottom of the screen, when you click the data by touching the screen or rotating the rotary key on the control panel.

If there is no data in the page, the focus can be found on [Print] button.

When there is no patient information you want to select, please press [<] or [>] button or the 'Search' menu to move to other pages.

- Menu direction (Rotary Key's right spin)

Print → Delete → Setup → Main → Page information → [<] → [>] → Info → Search → Print

- Menu direction (Rotary Key's left spin)

Print → Search → Info → [>] → [<] → Page information → Main → Setup → Delete → Print

2) Data printing

When selecting a saved data at the ECG file management page by using rotary key or touch screen, the focus will appear at the data list.

Press the 'Print' button to print out the data. Then you will see a message as shown below.

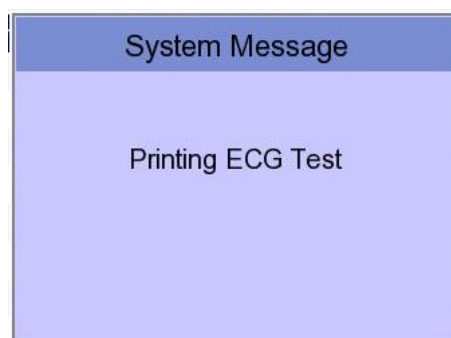

Note

You should avoid attaching and detaching a USB device while printing out, as it could cause the printer module to rattle.

3) Data deleting

When pressing the 'Delete' button, a small pop-up menu will show up. You can choose to press the 'select' or 'all' button.

When you press the 'Select' button, one data will be deleted, but if you press the 'All' button, all data in the list will be deleted.

In order to help the user not to make a mistake when deleting the data, a message shown as below will appear to reaffirm whether you really want to delete the data.

**Caution**

Please think carefully before selecting the 'All' button, as it will permanently delete all of the ECG data.

4) System Setup

When clicking the 'Setup' button at the ECG data file management page, you will see a 'System Setup' window as shown below.

The screenshot shows the 'System Setup' window. On the left is a vertical sidebar with buttons: Basic, Network, Hospital, FILE, Export, Service, and Exit. The main area contains the following elements:

- Date: 2022 - 05 - 20 (Y-M-D)
- Time: 09 : 58 : 53 (Setting)
- TouchScri button
- Language: ENG button
- Start Opt. Main button
- Units: cm/kg button
- Date Type: Y-M-D button
- PAT Info. Delete button
- DeviceName: HMG-EC-0012
- Device ID: NP000000
- OK, Cancel, and Default buttons at the bottom.

See "Chapter 2. 11) Setup".

4-1) Basic Setup

'PAT Info.' menu is to set up whether the patient information is retained or not, when you move the main screen of the Spiro/ECG. When you click the menu, 'Retain' will be set up and when clicking the menu again, 'Delete' will be set up. Default is set as 'Delete'.

- 'Delete': To set up the patient information is deleted, when you move to main screen of the Spiro/ECG.
- 'Retain': To set up the patient information is retained, when you move to main screen of the Spiro/ECG This may result in more than one record for the same patient.

4-2) File Setup

When clicking the 'FILE' button, you will see 'FILE' window as shown below.



You can activate the automatic deletion function by clicking the 'Auto Del.' menu in the 'FILE' menu window.

When the automatic deletion function is activated, when a new file is saved beyond the maximum storage capacity, the oldest file is deleted and then saved.

4-3) Export Setup

When clicking the 'Export' button, you will see 'Export' window as shown below.

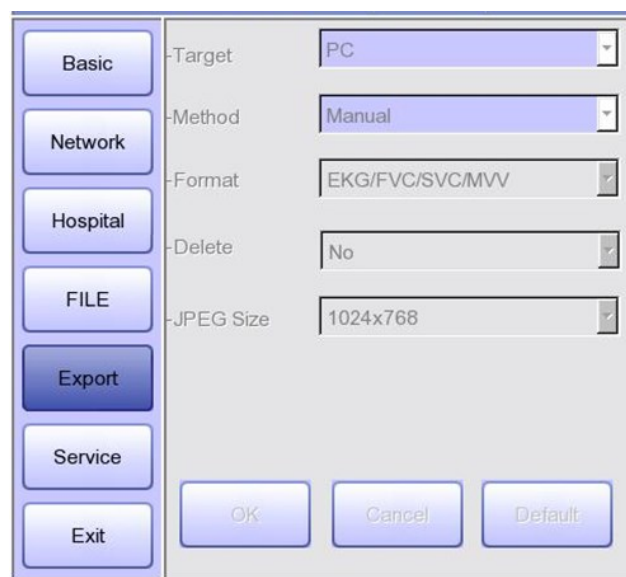

When clicking the 'Target' button, a POP-UP window will show up and it will disappear

when selecting one of BMS Server or USB.

- BMS Server/PACS Server
: To save the data in the BMS Server or PACS Server.
- USB: To save the data in the external USB Memory

When clicking the 'Method' button, a small line window will show up and it will disappear when selecting Manual, Select, All or All New.

- Manual: menu window allows user to select either 'Selected, All, All New, Cancel' or 'Selected, Cancel' whenever transferring data
- Select: To transfer the selected data
- All: To transfer all data
- All New: To transfer the newly saved data

When clicking the 'Format' button, a line window will show up and it will disappear when selecting EKG/FVC/SVC/MVV, MFER(ECG), XML(ECG), JPEG, PDF. 'Format' menu is used to select the user's options when transferring the data.

- EKG/FVC/SVC/MVV: To save the data by type of '***.ekg' / '***.fvc' / '***.svc' / '***.mvv'
- MFER: To save the data by type of '***.mwf'
- XML: To save the data by type of '***.xml'
- JPEG: To save the data by type of '***.jpg'
- PDF: To save the data by type of '***.pdf'
- DICOM: To save the data by type of '***.dcm'

When clicking the 'Delete' button, a line window will show up and it will disappear when selecting Yes or No. 'Delete' menu is used to select the user's options after the data has transferred.

- Yes: To delete the data after it has transferred
- No: To not delete the data after it has transferred

Note
- If 'Format' menu has only 'EKG/FVC/SVC/MVV' options, it is possible to select 'All' or 'All New' in 'Method' menu; for other formats, 'Selected' is the only option.

5) Switching menu

When selecting the 'Main' button at the main page of 'File management', a line window will show up. You can choose ECG, Spiro or Worklist to go to the chosen page.

The patient's information of selected data does not transmit when skipping to 'Worklist Management' screen. But it depends on the setting value of 'PAT Info.' menu when skipping to 'ECG' main screen.

- ECG: Skip to ECG main screen
- Worklist: Skip to 'Worklist Management' screen
- Spiro: Skip to spirometry measurement screen

6) Patient information

When selecting a saved data at the Spiro/ECG file management page by using a rotary key or a touch screen, the focus will appear at the data list.

Press the 'Info' button. Then you will see a 'Patient Information' window as shown below. Information other than patient name cannot be changed.

No.	ID	Name	Age	Date	Study
24	06262202	nhgkg	2	20180628	ECG

7) Data search

When clicking the 'Search' button at the Spiro/ECG data file management page, you will see a 'Patient Search' window as shown below. If you rotate the rotary key, the 'search condition' button will have focus. Press the 'Find' button after inputting the information about ID, Name, Date or Age.

When the search takes a long time, a message will show up to let you know the progress. After searching, you will see a data search result page.

The screenshot shows a software interface with a table of patient data and a 'Patient Search' dialog box. The table has columns for No, ID, Name, Age, Date, and Study. The search dialog box has a 'Search Condition' dropdown set to 'ID' and a list of search criteria including ID, Name, Day, and Age. Below the dialog box, the table continues with rows 20 through 24.

No	ID	Name	Age	Date	Study
1	11270410	phudg	0	20151127	ECG
2	11275510	gqafb	0	20151127	ECG
3	11275510	gqafb	0	20151127	ECG
4	7890	dvvv	32	20151127	FVC
Patient Search					
Search Condition: ID					
- ID: []					
- Name: []					
- Day: [] - [] - [] ~ []					
Y-M-D: [] - [] - []					
- Age: [] ~ []					
[Find] [Close] [All]					
20	193	193	0	20150720	ECG
21	194	194	0	20150720	ECG
22	189	189	0	20150720	ECG
23	190	190	0	20150720	ECG
24	191	191	0	20150720	ECG
[Print] [Delete] [Setup] [Main]					

8) Data transfer

You can transfer the saved data to the external device at the Spiro/ECG data file management page by using the 'NETWORK' key on the control panel.

When pressing the 'NETWORK' key, a message will show up, asking which menu you want to select.

The screenshot shows a dialog box titled 'FILE EXPORT MANUAL'. It asks 'Which menu do you want to select?' and provides four buttons: 'Selected', 'All', 'All New', and 'Cancel'.

If you transfer a selected data, a message with progress speed or other information will be shown as below.

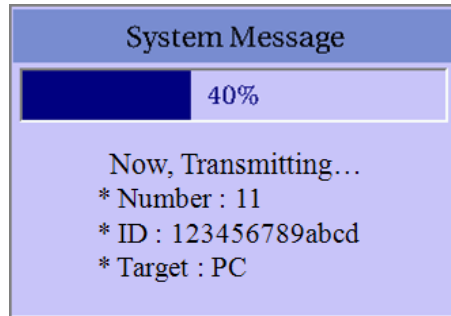

If you transfer all of the data, a message with progress speed or other information will be shown as below. In this case, the total number of files and the file being transferred currently will be displayed.

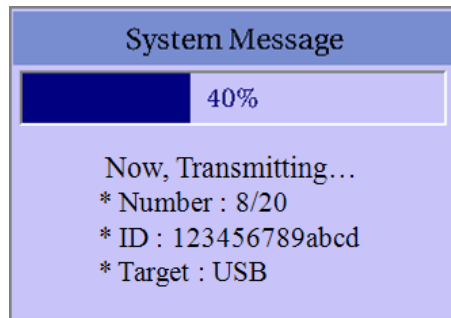

Note

When transmitting multiple sets of data to PC after saving, a network error could occur which may cause transmission halt and subsequent loss of data. Therefore, we recommend users to practice following procedures to minimize such loss.

1. In EKG Main, press [NET] button to transmit data to PC immediately after measuring.
2. When transmitting multiple sets of measurements, rather than sending all data at once, we recommend users to transmit individual records after each measurement.

Note

If the system boots up without having LAN cable connected, the network function may not work properly. In this case, enter [System] -> [Network] -> [OK] then press 'NETWORK' button to attempt running the network function again. Please refer Network Setup part of the manual to get more information regarding IP configuration setup.

9) Data import

You can import the saved data from the external device at the ECG data file management page by using the [RECORD] key on the control panel.

When pressing the [RECORD] key, 'Import File List' screen will be shown as below.

No	ID	Name	Age	Date	Study
1	ddfd1		0	19700101	ECG
2	abcdefg		0	19700101	FVC
3	12345678...		0	19700101	SVC
4	dog		0	19700101	MVV
5	abcdefg		0	20000101	MVV

FILE LIST MANAGEMENT	
No	Name
1	1234567890_19700101002436.SVC
2	111_20140101002029.MVV
3	7hh_20150101053631.MVV
4	abcdefg_19700101000101.FVC
5	abcdefg_20000101001909.MVV
6	abcdefg_20150101011837.MVV
7	ddfd1_19700101000750.ekg

Select All Close

Print Delete Setup Main

If 2 different USB memory devices are connected, a system message window prompting you to select one of them will appear.

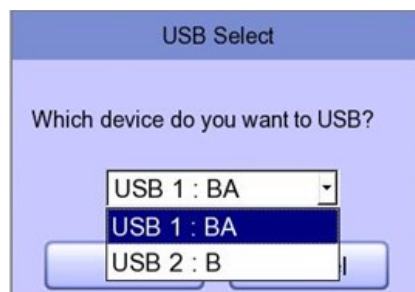

If the external device is not connected to Cardio7, the error message will be shown as below.



If you select the 'Selected' menu in the 'Import File List' screen, after receiving the selected data from the external device a system message will be shown as below.



If you select the 'All' menu in the 'Import File List' screen, a system message with progress speed will be shown as below.

After receiving all data from the external device, a system message will be shown as below.



Chapter 6. Worklist management

1) Display and function

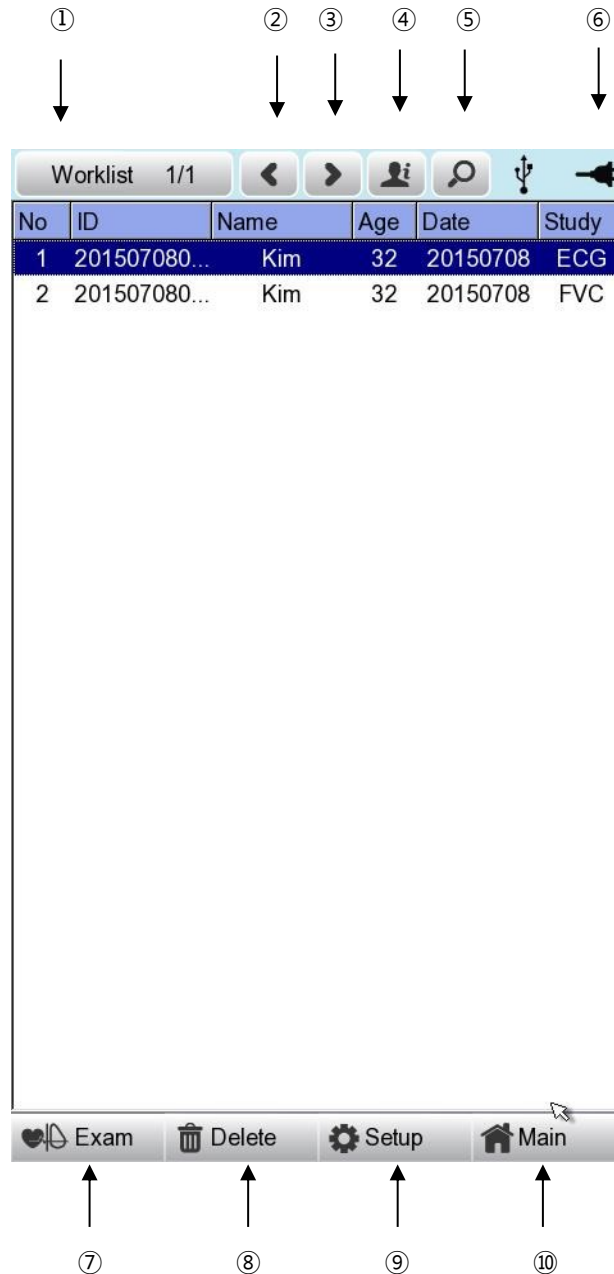

- ① Current page/total number of file pages
For example, [1/20] means that you see the first page among total 20 pages. 1 Page contains 24 Data.
If Rotary is selected, the focus will be moved to Data list.
- ② Go to the previous page.

- ③ Go to the next page.
- ④ Patient information
- ⑤ Worklist Search
- ⑥ Battery status or AC power connection status
- ⑦ Connection status of the external device.
- ⑧ Deleting a User button
(After interlocking with the PACS Server, press the 'Update' button)
- ⑨ Setup Menu
- ⑩ Touch this button to move to other menus such as ECG, Spiro, or File.

At the initial file management page, the first data of the list has the focus. The focus will automatically move to the menu bar at the bottom of the screen, when you click the data by touching the screen or rotating the rotary key on the control panel.

If there is no data in the page, the focus can be found on [Exam] button.

When there is no patient information you want to select, please press [<] or [>] button or the 'Search' menu to move to other pages.

- Menu direction (Rotary Key's right spin)

Exam → Delete → Setup → Main → Page information → [<] → [>] → Info → Search → Exam

-Menu direction (Rotary Key's left spin)

Exam → Search → Info → [>] → [<] → Page information → Main → Setup → Delete → Exam

We recommend using less than 200 work lists.

2) Spiro/ECG Test

Select 'Exam' button to go Spiro /ECG main screen in order to start ECG measurement with patient information in the test-requested data list.

There is no need to input additional information, as all the patient information is already saved upon Spiro / ECG test.

Caution

Each functional key action of Spiro / ECG Main Menu is as follows:

- RECORD: not saving measured data but performing output only.
- NET: not saving measured data but transferring it to a PC.
- AUTO: running according to Auto Key setup of system.

To save measured data for the Test requested, configure **Spiro / ECG Store on Auto Key setup as Yes**, and then start measurement by pressing the Auto button.

3) Data deleting

When pressing the 'Delete' button, a small pop-up menu will show up. You can choose to press the 'select' or 'all' button.

When you press the 'Select' button, one data will be deleted, but if you press the 'All' button, every data in the list will be deleted.

To help the user not to make a mistake when deleting the data, a message shown as below will appear to reaffirm whether you really want to delete the data.

**Caution**

Please think carefully before selecting the 'All' button, as it will permanently delete all of the ECG data.

4) System Setup

When clicking the 'Setup' button at the Spiro / ECG data worklist management page, you will see the 'worklist System Setup' window as shown below.

The screenshot shows the 'worklist System Setup' window. On the left is a vertical sidebar with buttons for 'Basic', 'Network', 'Hospital', 'Service', and 'Exit'. The 'Basic' button is highlighted. The main content area is divided into several sections:

- Date:** 2015 - 07 - 10 (Y-M-D format)
- Time:** 03 : 09 : 24
- TouchSern** (button)
- Lang:** ENG (button)
- Start Opt.:** Main (button)
- Units:** cm/kg (button)
- Date Type:** Y-M-D (button)
- DeviceName:** Cardio7 (text input field)
- Device ID:** NPFFFFFF (text input field)
- At the bottom are three buttons: **OK**, **Cancel**, and **Default**.

Note

The steps for Network, Hospital and Service Setting are identical with the steps for Spiro/ECG Main setting.

5) Switching menu

When selecting the 'Main' button at the main page of the ECG file management, a line window will show up. You can choose ECG or FILE to go to the chosen page.

The patient's information of selected data does not transmit, when moving to another main screen.

- ECG: skip to ECG main screen
- FILE: skip to 'File Management' screen
- Spiro: skip to spirometry measurement screen

6) Patient information

When selecting saved data at the ECG file management page by using rotary key or touch screen, the focus will appear at the data list.

Press the 'Info' button to see the 'Patient Information' page. After checking all the information, press the OK button and then the 'Patient Information' page will disappear.

The screenshot shows a mobile application interface with a 'Patient Information' form overlaid on a data list. The form contains the following fields and values:

ID	Name	Age	Date	Study
06262208	fufhr	6 - 26 - 2018	Date of birth	

The 'Patient Information' form fields include:

- ID: 06262208
- Name: fufhr
- F. Name: (empty)
- Age: 6 - 26 - 2018 (Date of birth)
- Gender: Female
- Height: (empty) cm
- Weight: (empty) kg
- Race: White
- Smoke: No
- Department: (empty)
- Room No: (empty)
- Study Desc.: ECG
- Accession No.: 262208
- Ref. Physician: JOHN DOE

The form has an 'OK' button at the bottom. The background shows a data list with columns for No., ID, Name, Age, Date, and Study. The bottom navigation bar includes Exam, Update, Setup, and Main.

7) Data search

When clicking the 'Search' button at the Spiro/ECG data order management page, you will see a 'Patient Search' window as shown below. If you rotate the rotary key, the 'search condition' button will have focus.

Press the [Find] button after inputting the information about ID, Name, Date or Age.

When the search takes a long time, a message will show up to let you know the progress. After searching, you will see a data search result page.

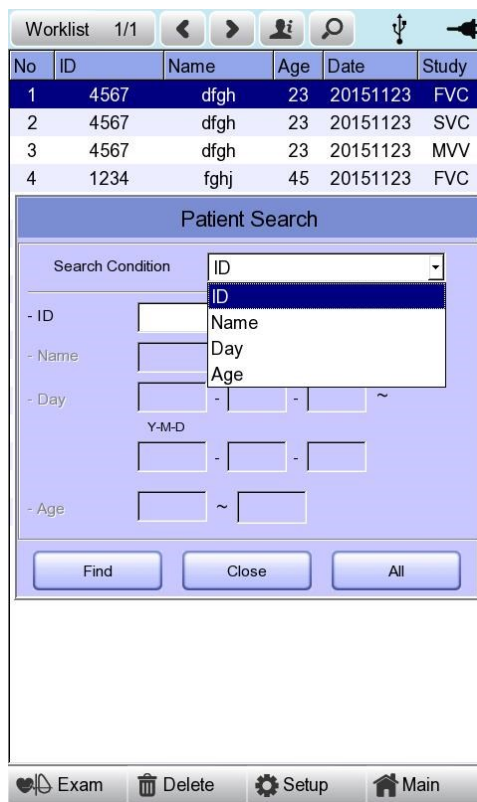

Chapter 7. System Management

1) Maintenance and Cleanliness

Keep Cardio7 equipment and handles clean. Avoid damaging or contaminating the equipment using the methods recommended below.

If you use the substances - including not allowed substances - that can damage on the product, warranty is not applied even during the warranty period.

Note
Clean the equipment and examine the body and electrodes thoroughly. Do not use old or damaged equipment.

At least once a month, wipe the body and measuring electrodes with a soft cloth moistened with alcohol to keep them clean. Do not use lacquer, thinner, ethylene, or oxide. Keep cables and limb and chest electrodes free of dust and dirt, and wipe them with a cloth dampened in lukewarm water (40°C/104°F) after use. Wipe them with clinical grade alcohol at least once a week. Do not immerse equipment or ECG wires in liquids or detergents. Keep the equipment and cables away from liquids.

Note
If the equipment is determined to be visibly unclean at the end of the cleaning steps, you should repeat the relevant previous cleaning process.

Note
If the equipment experiences unacceptable deterioration, such as corrosion, discoloration, dents, or cracked seals, contact the seller where you purchased the equipment and follow his or her instructions whether to dispose of or repair it.

Existing Device Disposal

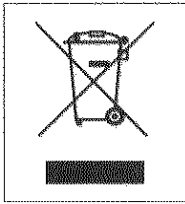

1. Products bearing this symbol (X-marked wheeled bins) are subject to European Directive 2002/96/EC.
2. All electrical and electronic products must be disposed of separately from municipal waste at the collection facility designated by government or local authorities.
3. Proper disposal of old devices helps prevent potential adverse consequences against environmental and human health.
4. For more information on the disposal of existing devices, contact City Hall, Waste Disposal Service Center, or the store where you purchased the product.

2) Regular Check-up

Like every other medical product, Cardio7 requires a regular check-up once a year. Please refer to the Service manual for the information on the check-up.

3) Trouble Shooting

- **Printing was not successful:**
The cover may not be closed properly. Please close the cover and print again.
- **When using the battery power, there was a beep for more than 3 times and a message came as shown below:**

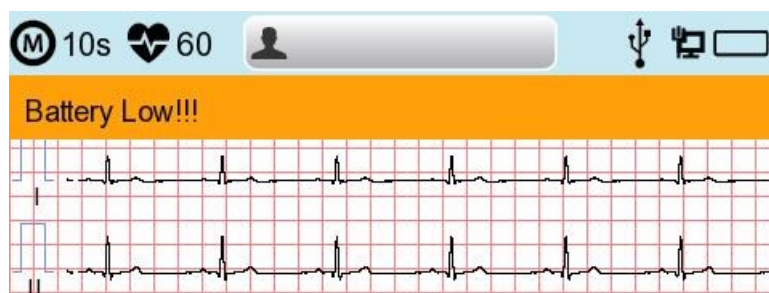

The battery is low. Please connect to the AC power to use.

- **The signal is printed out with noise:**
First, check that you set up the AC power filter. If it still makes noise with the AC power supply, please connect grounding line to the grounding electrode of the system.
The grounding should not be used with the AC power's grounding and please

connect it to the metal around the patient's bed or the building.

- **When the external USB keyboard is not working properly:**

Connect the external USB keyboard to the USB port before you turn on the power of Cardio7. If you connect the external USB keyboard to the USB port after you turn on the power of Cardio7, you should turn off the power of Cardio7 and turn on again.

- **Flickering screen when turning on the device**

This indicates that the battery is running low, and therefore it will disappear when the device is turned on again after connecting AC power.

If it is still not working, please contact our customer service center.

- **System messages**

The following system messages may occur while you are operating this system. You may be required to perform some action. If you perform the recommended actions and the condition still remains, contact authorized service personnel.

No.	System message	Cause	Solution
1	Please check date and time	Internal coin battery is discharged.	Please contact CS (Customer Support) team of Bionet to replace old coin type battery with new one
2	Address is not valid	When wrong network Address (IP, SM, GW) is entered	Check the right network address before input
3	Invalid value. [Use: 0~9, A~F]	When wrong character is entered at time of inputting Mac address	Please input valid character such as 0~9, A to F in number and alphabet respectively
4	There is no patient ID. Please enter patient ID.	When you implement AUTO or NET button without patient ID	Please enter patient ID in patient information window to implement
5	Wrong password. Please re-enter your password.	When wrong password is entered	Check and input right password

6	Enter password length error. Please re-enter your password	When wrong number of characters be entered as password	Please check and input valid and correct password
7	The internal memory is full. Please erase other files or transfer to external storage.	When over 200 files are stored at internal memory	Erase files in File menu
8	Not enough free disk space	USB memory device has insufficient space to receive files.	Remove unnecessary files from USB memory (Minimum 500KB space is needed to export 1 file)
9	Please check the USB memory.	When USB memory stick is not inserted, or is out of order	Please check and insert USB memory stick in right position. Note that USB memory file format supports FAT, FAT32 only (this can be checked on PC)
10	There is no Access Point. Please check the AP	There is no wireless access point detected.	Check AP and retry
11	Fail, connecting. Do you want to retry?	When wireless AP connection is failed	- Press Retry button - Retry after checking AP
12	Ping: Failed	When there is connecting failure between network and PC with BMS Server	-Check System setup and network - Check PC network setup -Check LAN cable or wireless environment
13	Verify: C-Echo Failed	When there is failure between PACS Server PC and network	- Check system setup and network - Check PC network setup -Check LAN cable or wireless environment -Please check PACS programs are working

14	IP address conflict.	The devices IP address is already in use on the network	Please contact 'Network Team' to check IP address, and set right IP in turn of System setup and Network
15	Connection Error. Check Lan cable, network setting and relevant program.	When there is failure of network connection	Please check LAN cable connection, network setting, server PC's networking and related S/W programs
16	File Trans Fail!!	When file transmission to server PC or USB memory fails	Check server PC's networking conditions, and USB memory, and retry
17	Check Worklist Server IP	When server IP of PACS worklist is not input	Input server IP of PACS worklist in turn of System setup, Network and PACS setting
18	Check Device AE Title	When AE Title of device is not input	Input AE title of device in turn of System setup, Network and PACS setting
19	Check Device Port	When port of device is not input	Input port of device in turn of System setup, Network and PACS setting
20	Check Worklist Server Port	When server port of PACS Worklist server is not input	Input server port of PACS Worklist server in turn of System setup, Network and PACS setting
21	Check Store AE Title	AE title of PACS store server is not input	Input AE title of PACS store server in turn of System setup, Network and PACS setting
22	Fail to send Image	When file transmission to PACS store server has failed	Retry after checking network conditions
23	Fail to connect Store Server	When there is connection failure between PACS store server and device	Check network condition with PACS store server
24	Transmission failed file is existing. Are you sure to delete?	When the transmission failed file to PACS store server needs to be deleted	Delete the failed file after transmitting the file to PACS store server

25	Recharge Battery!	When the battery level is Low	Please connect power cable or charge battery
26	Printer: Time out.	Printer stops working due to technical problem of device	React the printer
27	Printer: Busy continue	When the wrong printer data were input	React the printer
28	Printer: Temperature high	When the Printer gets heated due to long and continuous use of printer	Please stop the use of printer for at least one minute and try again
29	Printer: Paper empty	When the printing paper is completely out	Please put new roll of printing paper for use
30	Printer: Printer not ready	When there is no 'ready' answer from printer module	React the printer
31	Printer: Unknown data	When the wrong protocol was put into the printer	React the printer
32	Abnormal End!	When the printer was abnormally forced to stop during printing	Re-start printing
33	Lead Fault!	When the lead is off from the patient body	Please reattach the electrode on patient body
		When the conductivity between patient body and electrode is weak	Apply some water to reusable electrodes, and reattach them
34	No ECG Recorded Data!	When the user tries to execute copy printing without any recording data	Try make copy after recording data by "RECORD", "AUTO", and "NET" button
35	Please check handle!	- When the Spirometer handle is not connected - When the spirometer handle is disconnected during test	Check the Spirometer handle is connected

36	Correction factor(s) outside of acceptable range of 0.8~1.2	When the factor value is out of tolerance range during the calibration	Repeat the calibration until the calibrated values are within the tolerance range
37	Please repeat the calibration until the calibrated value reaches the tolerance range 3% (2.91~3.09L)!	When the difference values are out of tolerance range during the calibration	Repeat the calibration until the calibrated values are within the tolerance range
38	Fail : Time out!!	- When the calibration time is exceeded - When the FVC test time is exceeded	React the calibration React the FVC test
39	The breath protocol Failed!	When the test protocol goes wrong	Re-test with right test protocol of FVC, SVC and MVV
40	Examination Zeroing Fail!	When the zeroing of spirometer handle is failed	React the test
41	Examination Start Fail!	When initialization is failed	React the test after initialization
42	Fill patient information	When necessary patient information is not input	Fill all necessary information(*) in patient information window, and retry the test

4) Manufacturer's Declaration

Electromagnetic compatibility_ Guidance and manufacturer's declaration

Guidance and manufacturer's declaration – electromagnetic emissions		
The Cardio7 is intended for use in the electromagnetic environment specified below. The customer or the user of the Cardio7 should assure that it is used in such an environment.		
Emissions test	Compliance	Electromagnetic environment - guidance
Mains terminal disturbance voltage CISPR 11	Group 1 Class A	The EMISSIONS characteristics of Cardio7 make it suitable for use in industrial areas and hospitals (CISPR 11 class A). If it is used in a residential environment (for which CISPR 11 class B is normally required) this equipment might not offer adequate protection to radio-frequency communication services. The user might need to take mitigation measures, such as relocating or re-orienting the equipment.
Radiated disturbance CISPR 11	Group1, Class A	
Harmonics IEC 61000-3-2	Class A	The Cardio7 is suitable for use in all establishments other than domestic, and may be used in domestic establishments and those directly connected to the public low-voltage power supply network that supplies buildings used for domestic purposes, provided the following warning is heeded:
Voltage fluctuations/Flicker IEC 61000-3-3	Complies	Warning: This equipment/system is intended for use by healthcare professionals only. This equipment/ system may cause radio interference or may disrupt the operation of nearby equipment. It may be necessary to take mitigation measures, such as re-orienting or relocating the Cardio7 or shielding the location.

Guidance and manufacturer's declaration – electromagnetic immunity			
The Cardio7 is intended for use in the electromagnetic environment specified below. The customer or the user of the Cardio7 should assure that it is used in such an environment.			
IMMUNITY test	IEC 60601 test level	Compliance level	Electromagnetic environment - guidance
Electrostatic Discharge Immunity (ESD) IEC 61000-4-2	± 8 kV/Contact $\pm 2, \pm 4, \pm 8, \pm 15$ kV/Air	± 8 kV/Contact $\pm 2, \pm 4, \pm 8, \pm 15$ kV/Air	Floors should be wood, concrete or ceramic tile. If floors are covered with synthetic material, the relative humidity should be at least 30 %.
Radiated RF Electromagnetic Field Immunity IEC 61000-4-3	3 V/m 80 MHz - 2.7 GHz 80% AM at 1 kHz	3 V/m 80 MHz - 2.7 GHz 80% AM at 1 kHz	Cardio7 is suitable to use in professional healthcare environment.
Immunity to Proximity Fields from RF wireless Communications Equipment IEC 61000-4-3	28 V/m Max. 385-5785 MHz in according to table 9 in IEC 60601-1-2	28 V/m Max. 385-5785 MHz in according to table 9 in IEC 60601-1-2	RF communication equipment is used no closer than 30 cm to any part of the Cardio7, including cables specified by Bionet.
Electrical Fast Transient/Burst Immunity IEC 61000-4-4	± 2 kV, 100 kHz repetition frequency	± 2 kV, 100 kHz repetition frequency	The quality of supplied power should be suitable for general business site or hospital environment
Surge Immunity IEC 61000-4-5	Line to Line ± 0.5 kV, ± 1 kV Line to Ground ± 0.5 kV, ± 1 kV, ± 2 kV	Line to Line ± 0.5 kV, ± 1 kV Line to Ground ± 0.5 kV, ± 1 kV, ± 2 kV	The quality of supplied power should be suitable for general business site or hospital environment.
Immunity to Conducted Disturbances Induced by RF fields	3 V 0.15 MHz - 80 MHz 6 V in ISM bands between 0.15 MHz	3 V 0.15 MHz - 80 MHz 6 V in ISM bands between 0.15 MHz and	The strength of RF field in the frequency range higher than 150kHz~80MHz, the strength of the RF field is smaller than 3 V

IEC 61000-4-6	and 80 MHz 80% AM at 1 kHz	80 MHz 80% AM at 1 kHz	
Power Frequency Magnetic Field Immunity IEC 61000-4-8	30 A/m 50 & 60 Hz	30 A/m 50 & 60 Hz	Power frequency magnetic fields should be at levels characteristic of a typical location in a typical domestic, residential or Home Health Care environment.
Voltage dips IEC 61000-4-11*	0 % U_T ; 0.5 cycle At 0°, 45°, 90°, 135°, 180°, 225°, 270° and 315° 0 % U_T ; 1 cycle and 70 % U_T ; 30 cycles Single phase: at 0°	0 % U_T ; 0.5 cycle At 0°, 45°, 90°, 135°, 180°, 225°, 270° and 315° 0 % U_T ; 1 cycle and 70 % U_T ; 30 cycles Single phase: at 0°	Mains power quality should be that of a typical residential or hospital environment. If the user of the Cardio7 requires continued operation during power mains interruptions, it is recommended that the Cardio7 be powered from an uninterruptible power supply or a battery be used with the system power source.
Voltage interruption IEC 61000-4-11*	0 % U_T ; 250/300 cycles	0 % U_T ; 250/300 cycles	
Radiated fields in close proximity IEC 61000-4-39	65 A/m Max 30 kHz - 13.56 MHz in according to table 11 in IEC 60601-1-2	65 A/m Max 30 kHz - 13.56 MHz in according to table 11 in IEC 60601-1-2	Cardio7 is suitable to use in professional healthcare environment. Portable radio frequency (RF, RFID) communication devices can interfere with the medical electrical device. Therefore, do not use your mobile phone in a medical office or hospital environment
*Note: U_T is the AC voltage of the power before using test level			

Chapter 8) Specification

ECG	
ECG Leads	Simultaneous 12 Leads Resting ECG
Recording Channel	3CH+1RHY, 3CH+3RHY, 6CH+1RHY, 12CH, 6CH+ST map, 1CH+3, Cabrera Report 1CH Long Time (1min, 3min, 5min,10min) and Special Beat Report (Text, Guide, Vector, ST map)
Gain	2.5, 5, 10, 20, Auto (I~aVF: 10, V1~V6: 5) mm/mV
Printing Speed	5, 12.5, 25, 50, 100 mm/sec
Sampling Rate	Analysis Sampling Rate - 500 Digital Sampling Rate - 8,000
Filters	AC (50/60 Hz, -20dB or better), Muscle (25~35Hz, -3dB or better), Baseline drift (0.05Hz, 0.1Hz, 0.2Hz, -3dB or better), Low pass filter (off, 40Hz, 100Hz, 150Hz)
Patient data	ID, name, age, gender, height, weight, race, smoke, department, room number, study desc., accession no., referring physician
Basic Measurement	Heart rate (30~300bpm, ± 3 bpm), PR/RR int., QRS dur., QT/QTc int., P-R-T axis, SV1/RV5/R+S amp.
Electrical	Internal noise: 20uV(p-p) max Input impedance: $\geq 50M\Omega$ Input voltage range: ± 5 mV CMRR: > 105 dB DC offset voltage: $\geq \pm 400$ mV Patient leakage current: < 10 uA Frequency response: 0.05 ~ 200 with in -3 dB Isolated, defibrillation and ESU protected
Signal Quality Control	Pacemaker pulse detection Lead fault detection, Signal Saturation Detection

Spiro	
Measuring values	FVC: FVC, FEV1, FEV1/FVC, FEF 0.2-1.2L, FEF 25-75%, FEF 75-85%, PEF, FEF 25%, FEF 50%, FEF 75%, FIVC, FEV6, PEFT, FET 100%, Error Code, Extrapolation volume SVC: SVC, TV, ERV, IRV, EC MVV: MVV, FB, TV
Presentation	Flow Volume loop Volume Time Graph Measurement values table
Measuring range	Flow: 0 to ± 14 L/s Volume: 0 to ± 12 L
Measuring method	Differential pressure method
Prediction equation	Morris-Polgar, Knudson-ITS, ECCS-Quanjer, Korea CJK, Pereira
Sample rate	200 samples/sec
Flow impedance	< 0.2 mbar s/L at 12 L/s
Measuring accuracy	Complies with ISO 26782, ISO 23747
Common	
Data Storage	Internal Storage for 200 ECGs: Built- in memory
Display	800 x 480 pixel resolution, 7" Color TFT wide display 12 channels preview, ID, HR, Gain, Speed, Power status
User Interface	Touch screen (Alphanumeric and symbol available) Rotary push-knob
Printer Resolution	Thermal print head, Roll Paper Report paper - width: A4/Letter 215mm (8.5") - length: A4 297 mm (11.7") Letter 279mm (11") Resolution: 8dot/mm (0.125mm pitch)
Line Power	Input: 100-240Vac, 1.5-0.75A, 50-60Hz, Output: 15Vdc, 4.2A

Battery type		Replaceable and Rechargeable, Lithium ion, 10.8V, 3250mA
Battery Capacity		6 hours of normal use or print 200 ECG pages (12 channel format at 25mm/s and 10mm/mV) The battery will charge to its full capacity within 3 hours with the power off.
Communication		LAN, WIFI (option), USB flash driver, USB barcode scanner
Safety Conformity		Class I, Type CF defibrillation-proof applied part.
Environmental	Operation	Ambient Temperature: 10~40°C Relative Humidity: 30~85%RH Atmospheric Pressure: 70~106KPa
	Storage/Ship	Ambient Temperature: -20~60°C Relative Humidity: 10~95%RH Atmospheric Pressure: 50~106KPa
Dimension		300(W) x 290(D) x 97.5(H)mm, Approx. 3.5kg (Main Body) 48(W) x 39(D) x 201(H) mm, approx. 250g (Spiro Handle)
Standard Accessory		Patient Cable (1ea.), Limb Electrodes (1 set), Chest Electrodes (1 set), ECG Paper (1ea.), Power Cable (1ea.), ECG Gel (1ea.) Quick Manual (1ea.), ECG Diagnostic Guide (1ea.), Operation Manual (1ea.)
Options		Rechargeable Battery (1ea.) Spiro Handle (1ea.), Spiro Diagnostic Guide (1ea.) Disposable Mouthpiece (2ea.), Nose Clip (1ea.) Mouthpiece Adapter (1ea), Handle Supporter (1ea.), Spiro Connector (1ea.), Disposable Mouthpiece 1 box (100ea.), PFT Filter (20ea), Calibration Syringe[3L] (1ea)

Warning

Do not touch patient cables or equipment when using a ventricular defibrillator.

Warning

When connecting electrodes or patient cables, do not allow connectors to touch conductive parts or ground. In particular, when attaching the electrodes to the patient's body, make sure that they do not come into contact with conductive parts or the ground.

Warning

Do not use the supplied ECG patient cables to measure respiration. They should be used for ECG measurement only.

Caution

For the electrode, use the same product as provided or a product with biocompatibility certified by international standards.

Caution

Cardio7 should be used in the presence of a health care professional when used for patients who have undergone Cardiac Assist Device surgery.