

How to start the device

Please check the following Before using the device.

I Operating procedure I

- Connect the power cable to the device.
- Run the 'CardioSync' program
- Connect the leads to the patient according to the ECG preparation steps.
- Check the settings of filter, signal size, output speed, channel configuration, rhythm lead, etc. and set them to the desired values if you want to modify them.
- Enter patient information according to the patient information input method.
- If the waveform displayed on the PC screen is abnormal or there is a lot of noise, take action according to the 'Correspondence for bad lead wiring'.
- If the waveform displayed on the PC screen is normal, press the AUTO key to record the patient's ECG.
- Press the 'STOP' key while saving ECG to stop the operation.

How to read the eIFU

- 1) <https://www.ebionet.com/operation-manuals/>
- 2) After entering the provided password, you can download the eIFU.

PW: C9Mbh5

Product Configuration

Basic composition and accessories

- ① Cardio P1 Main Body (1EA)
- ② Patient Cable (1EA)
- ③ Limb Electrodes (1SET)
- ④ Chest Electrodes (1SET)
- ⑤ Power (USB Data) Cable (1EA)
- ⑥ USB Lock Key (1EA)
- ⑦ ECG Diagnosis Guide (1EA)

Body Configuration

■Top View

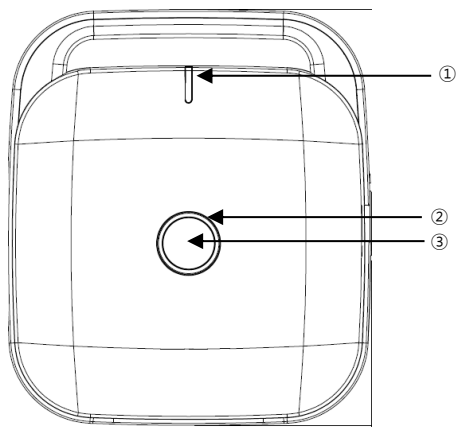

- ① Indication Part (LED) : Part showing the power connection status of a product
- ② Indication Part (LED) : Part that informs the lead connection status
- ③ Function Switch: Start record (push more than 3 seconds), event marker key

■Bottom View

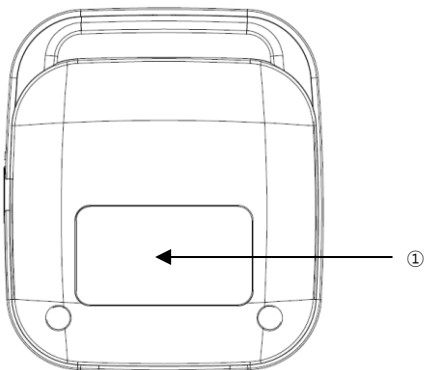

- ① ID Label : Part to attach ID Label

Side View

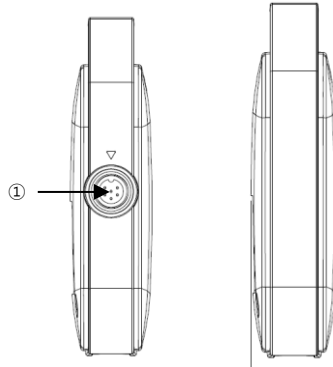

① Power (USB Data) Cable Connection Port

Rear View

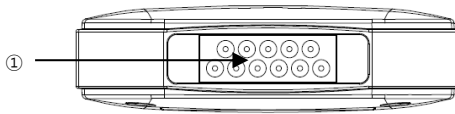

① ECG Cable Connection Port

Control Key	Status Display
	<p>Auto / Event.</p> <p>1. Short Press Performed to mark as a marker when abnormalities such as arrhythmias were felt in the ECG diagnostic test</p> <p>2. Long Press (more than 3 seconds) Perform the operation that is the most frequently performed in the saving, transmission and printing of data in the ECG diagnosis test with one key</p>

Trouble Shooting

- When the signal is output with a lot of noise

In this case, first check whether the AC power filter is set. If it is set and still noisy, connect a ground wire to the system's ground electrode.

The grounding should not be used with the AC power grounding. Connect it to a nearby patient bed or metal connected to the building.

- Cybersecurity-related issues

- 1) In case of equipment theft or loss, immediately report it to the hospital staff or the manufacturer. When receiving a report, the hospital network administrator must take measures to prevent the device from accessing the hospital network.
- 2) If a cyber security threat is detected while using the device, immediately disconnect the device from the network and contact the hospital official or manufacturer.

※ Please refer to the contact information below for the manufacturer's contact information.

Specification

ECG Leads	Simultaneous 12 channel ECG and acquisition
Recording Channel	3CH+3RHY, 3CH+1RHY, 6CH+1RHY, 12CH, 6CH+ST map 1CH Long Time (1min, 3min, 5min, 10min, 20min, 30min) and Special Beat Report (Text, Guide, Vector, ST map)
Gain	2.5, 5, 10, 20, Auto (I~aVF: 10, V1~V6: 5) mm/mV
Printing Speed	5, 12.5, 25, 50, 100 mm/sec
Sampling Rate	Analysis Sampling Rate - 500Hz Digital Sampling Rate - 8,000Hz
Filters	AC (50/60 Hz, -20dB or better), Muscle (25~35Hz, -3dB or better), Baseline Drift (0.05Hz, 0.1Hz, 0.2Hz, -3dB or better), Low Pass Filter(off, 40Hz, 100Hz, 150Hz)
Patient Data	ID, Name, Birthday, Age, Gender, Height, Weight, Race, Smoke, Department, Room No., Study Desc., Accession No., Referring Physician
Basic Measurement	Heart Rate (30~300bpm, ± 3 bpm), PR/RR Int, QRS Dur, QT/QTc Int, P-R-T axis, SV1/RV5/R+S Amp

Electrical		Internal Noise : 20uV(p-p)max Input Impedance : $\geq 50M\Omega$ Input Voltage Range : $\pm 5mV$ CMRR : $> 105dB$ DC Offset Voltage : $\geq \pm 400mV$ Patient Leakage Current : $< 10uA$ Frequency Response : 0.05~200 with in -3dB Isolated, Defibrillation and ESU Protected
Signal Quality Control		Pacemaker Pulse Detection Lead Fault Detection, Signal Saturation Detection
Input Power		5VDC (USB), Max. 0.5A
Communication		USB data communication (to PC)
Safety Conformity		Class I, Type CF applied parts: ECG electrodes
Environm ental	Operation	Ambient Temperature : 10 to 40°C Relative Humidity : 30 to 85% Atmospheric Pressure : 700 to 1060hPa
	Storage/Sh ip	Ambient Temperature : -20 to 60°C Relative Humidity : 10 to 95% Atmospheric Pressure: 500 to 1060hPa
Dimensions		Body - 90.75(W) x 103.5(D) x 24.93(H)mm - Approx. 110g
Standard Accessory		Patient cable (1 EA), Limb electrodes (1 SET), Chest electrodes (1 SET), Power (USB data) cable (1 EA), Hanger (1 EA), Rubber belt (1 EA), ECG Gel (1EA) Operation manual (1 EA), ECG diagnosis guide (1 EA) USB Lock Key (1 EA)

Request for Instructions for use in paper form

Electronic form instructions are now being widely used to reduce paper consumption, increase accessibility for users. Instructions for use of the device are supplied in electronic form instead of in paper form. Instructions for use in paper form can be requested at no additional cost within 7 calendar days from our distributors by mail.