

CANDO®



Magneciser®

pedal exerciser

REF 01-8030



Bi-directional upper and lower body exerciser with magnetic resistance for smooth operation

MAGNETIC™
RESISTANCE

TABLE OF CONTENTS

Assembly Instructions	3-4
Electronic Monitor	5
Safety Precautions	6
Operating Instructions	7



Use on a tabletop for upper body exercise



Use on the floor for lower body exercise

ASSEMBLY PARTS

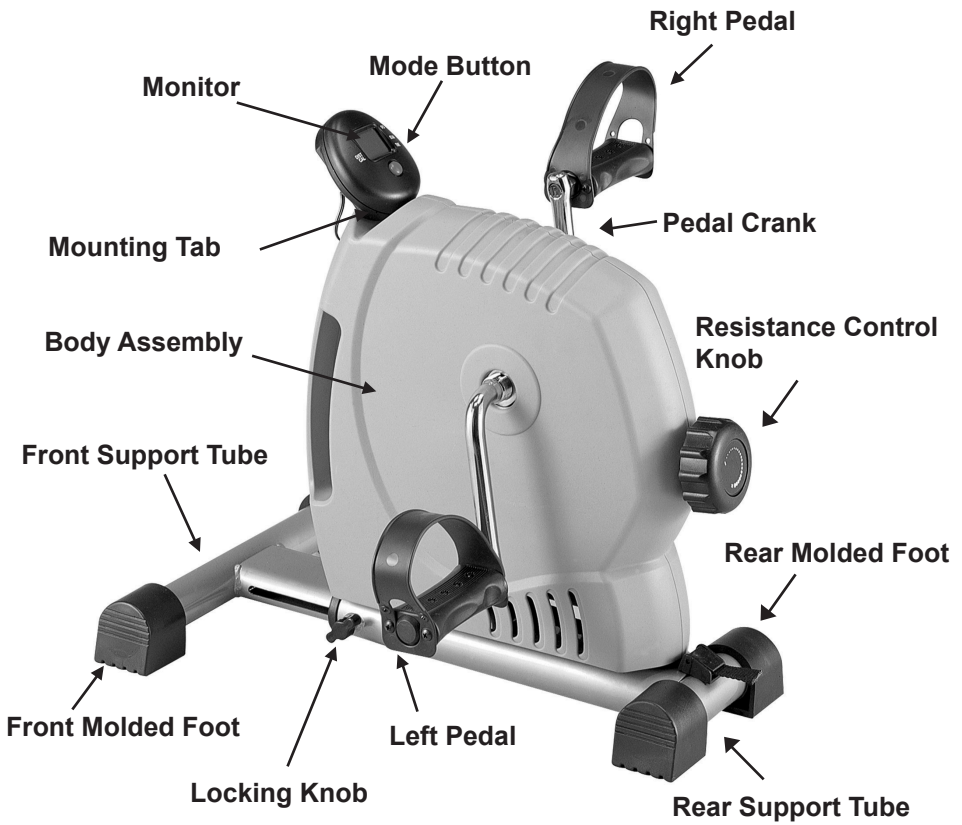

ASSEMBLY INSTRUCTIONS

Step 1: Insert the Front support tube into the body assembly and adjust it to the desired position. Then attach the locking knob and tighten it.

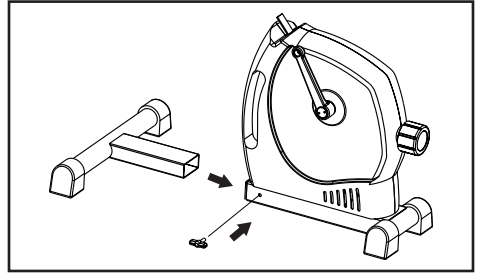

Step 2: Screw the left pedal into the pedal crank by turning the pedal counter-clockwise. Tighten using the wrench.

Screw the right pedal into the pedal crank by turning the pedal clockwise. Tighten using the wrench.

Note: L and R stickers and engravings on the unit and pedals show which direction to screw the pedal into the pedal crank.

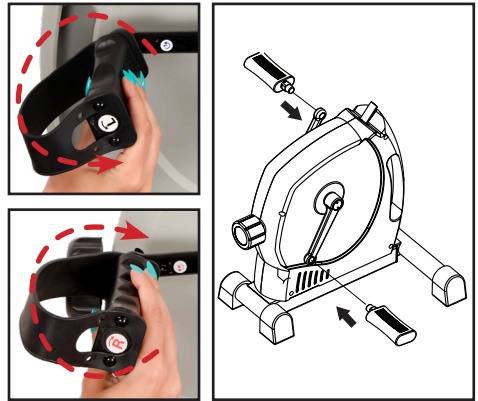

Step 3: Plug the monitor wire to the monitor and slide monitor completely onto mounting tab.

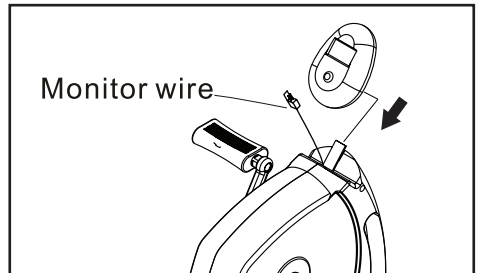

Step 4: The resistance knob controls the amount of resistance applied against the pedal movement. Turn the resistance knob clockwise to increase resistance (for a more difficult workout), and counter clockwise to decrease resistance (a less difficult workout).

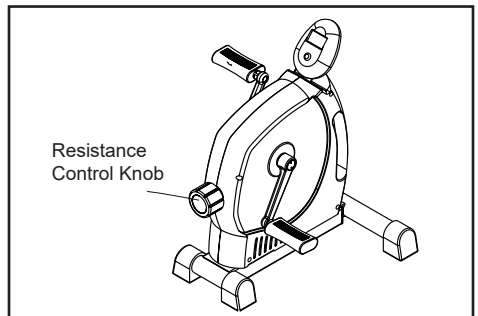

ELECTRONIC MONITOR

FUNCTION BUTTON MODE: Use to select functions: time, speed and distance. Hold the “MODE” button for 2 seconds to reset all values.

SCAN: Press “MODE” button to select “SCAN” mode with a “SCAN” sign on the upper left corner of the monitor. This function will automatically scan through all the functions displayed on the bottom line of the monitor.

TIME: Automatically accumulates workout time when starting exercise.

SPEED: Displays current speed during workout.

DISTANCE: Automatically accumulates distance “traveled” during workout.

NOTE:

1. If an improper display is seen on the monitor replace the batteries.
2. Monitor uses two 1.5v “AA” batteries for power supply.
3. The monitor will automatically shut off if no input signal is received for a 4 to 5 minute period.
4. Monitor will automatically start when you begin exercising or press the button.



SAFETY PRECAUTIONS

CAUTION

Read this instruction guide before using your Pedal Exerciser and follow all safety precautions.

- Check unit before each use to make sure it is in working condition. Never operate this unit if it is not functioning properly.
- Handle unit with care.
- DO NOT permit any foreign materials or liquids to enter the unit.
- DO NOT modify or remodel the unit.
- Always operate this unit on a level surface.
- This unit should not be used by or near children.
- Handicapped or disabled people must have medical approval before using unit, and should be under close supervision when using any exercise equipment.
- Do not put hands, feet, or any foreign objects on or near this unit when in use by other people.
- Use caution to prevent fingers or hands from being pinched in moving parts when operating the unit.
- Use this unit only for its intended purpose described in this manual.
- If you have difficulty operating the unit after carefully reviewing this operator's guide, contact your dealer for assistance.
- Failure to use and maintain the Pedal Exerciser in accordance with the instructions outlined in this manual will invalidate your warranty.
- Dispose of product in accordance with applicable regulations and codes.
- Consult your healthcare professional before beginning an exercise program with this machine. Ask what exercise program is best for you including warm-up, amount of exercise, and cool-down. No specific health claims are made or implied as they relate to the equipment.
- Know your heart rate and pulse, as well as your physician recommended target heart rate. Monitor these during exercise.
- If the user experiences dizziness, nausea, chest pain, or any other abnormal symptoms, stop the exercise at once and consult a physician immediately.
- Warm up before exercise program with stretching or as advised by your healthcare provider.
- Wear comfortable clothes that allow freedom of movement and are not tight or restricting.
- Wear comfortable shoes with good support and nonslip soles.
- Breathe naturally, and never hold your breath during an exercise.
- Perform exercises consistently with proper technique, and with a full range of motion.
- Avoid over-training.
- Start exercising slowly then you may wish to gradually increase the amount of resistance on the exerciser.
- After an exercise session, cool down with slow stretching, cycling, or walking.

Disposal Information: Dispose of item in accordance with the local/regional/national/international regulations.

OPERATING INSTRUCTIONS

Upper body exercise:

Place this product on a level table. Put your hands on the pedals and cycle arms forward or backward.

Note: The front support tube is adjustable. Unscrew the knob then slide tube in or out of the assembly to adjust the distance from the exerciser. Tighten knob again before exercising.



Lower body exercise:

Place this product on a level floor. Put your feet on the pedals and cycle forward or backward.

Remember: To increase resistance turn knob clockwise.



