

# CANDO®

## *SHOULDER EXERCISER*

bi-directional  
exerciser



with magnetic resistance for smooth operation



**TABLE OF CONTENTS**

Safety Precautions .....	3-4
Assembly Parts & Hardware Pack .....	5
Mounting and Assembly .....	6-7
Parts List .....	8
Assembly Diagram .....	9
Electronic Monitor .....	10
Operating Instructions .....	11

## SAFETY PRECAUTIONS

Read this instruction guide before using your Shoulder Exerciser and follow all safety precautions.

### CAUTION

- Check unit before each use to make sure it is in working condition. Never operate this unit if it is not functioning properly.
- Make sure unit is securely fastened to wall before each use.
- Handle unit with care.
- **DO NOT** permit any foreign materials or liquids to enter the unit.
- **DO NOT** modify or remodel the unit.
- This unit should not be used by or near children.
- Handicapped or disabled people must have medical approval before using unit, and should be under close supervision when using any exercise equipment.
- Do not put hands, feet, or any foreign objects on or near this unit when in use by other people.
- Use caution to prevent fingers or hands from being pinched in moving parts when operating the unit.
- Use this unit only for its intended purpose described in this manual.
- If you have difficulty operating the unit after carefully reviewing this operator's guide, contact your dealer for assistance.
- Failure to use and maintain the Shoulder Exerciser in accordance with the instructions outlined in this manual will invalidate your warranty.
- Dispose of product in accordance with applicable regulations and codes.
- Consult your healthcare professional before beginning an exercise program with this machine. Ask what exercise program is best for you including warm-up, amount of exercise, and cool-down. No specific health claims are made or implied as they relate to the equipment.
- Know your heart rate and pulse, as well as your physician recommended target heart rate. Monitor these during exercise.
- If the user experiences dizziness, nausea, chest pain, or any other abnormal symptoms, stop the exercise at once and consult a physician immediately.
- Warm up before exercise program with stretching or as advised by your healthcare provider.

- Wear comfortable clothes that allow freedom of movement and are not tight or restricting.
- Wear comfortable shoes with good support and nonslip soles.
- Breathe naturally, and never hold your breath during an exercise.
- Perform exercises consistently with proper technique, and with a full range of motion.
- Avoid over-training.
- Start exercising slowly and gradually increase the amount of resistance on the exerciser.
- After exercise session, cool down with slow stretching, cycling, or walking.

## ASSEMBLY PARTS

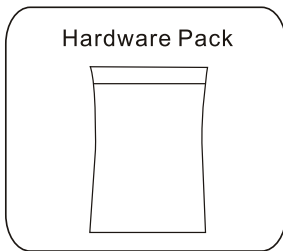
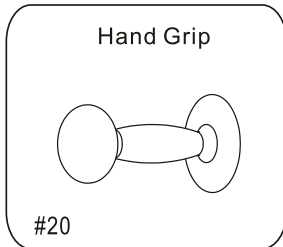
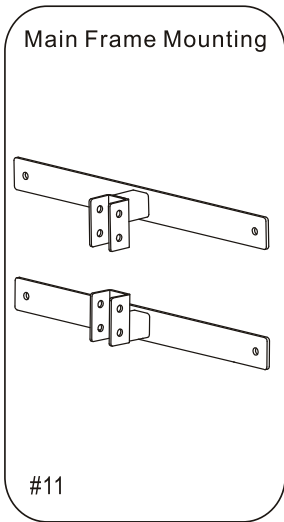
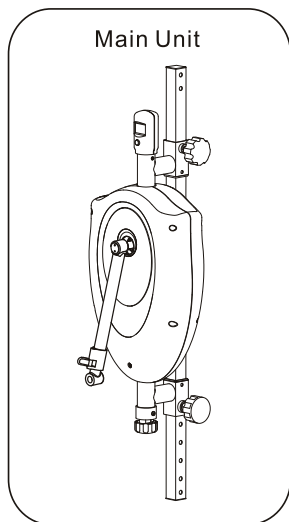

## HARDWARE PACK

<p>Socket Head Screw (M8x50L) 4pcs</p> <p>#13</p>	<p>Hex head screw (1/4 x 2) 4pcs</p> <p>#16</p>	<p>Flat Wrench</p>
<p>Flat Washer (<math>\phi 8.5 \times \phi 16 \times 1.5t</math>) 4pcs</p> <p>#14</p>	<p>Flat Washer (<math>\phi 1/4 \times \phi 14 \times 1.0t</math>) 4pcs</p> <p>#17</p>	<p>Flat Wrench</p>
<p>Nylon nut (M8) 4pcs</p> <p>#15</p>	<p>Wall mount 4pcs</p> <p>#18</p>	<p>Allen wrench</p>
		<p>1.5v AA Battery 1Pc</p>

**MOUNTING and ASSEMBLY**

**STEP 1.**

Attach the Main Unit to the Main Frame Mounting (#11). Then secure it with four M8X50L Socket screws (#13), four Flat washers (#14) and four M8 Nylon Nut (#15).

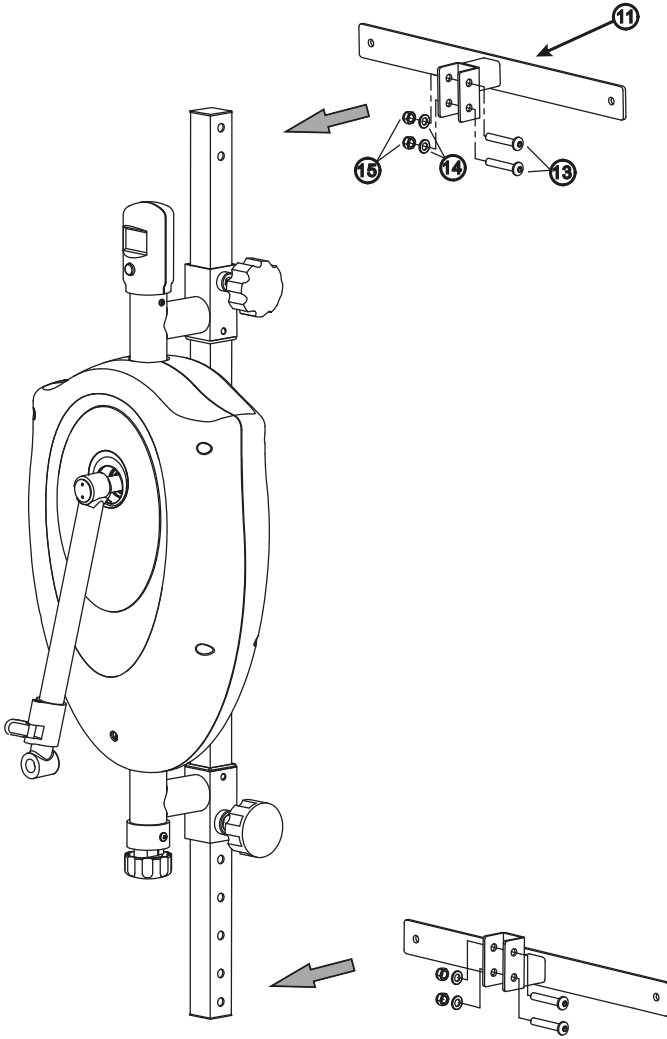

## STEP 2.

Secure the Main Unit to a level wall, board with four Hex Head screw (#16), four Flat washers (#17) and four Wall mounts (#18). Attach the Hand Grip (#20) to the Handle bar (# 03) and tighten it.

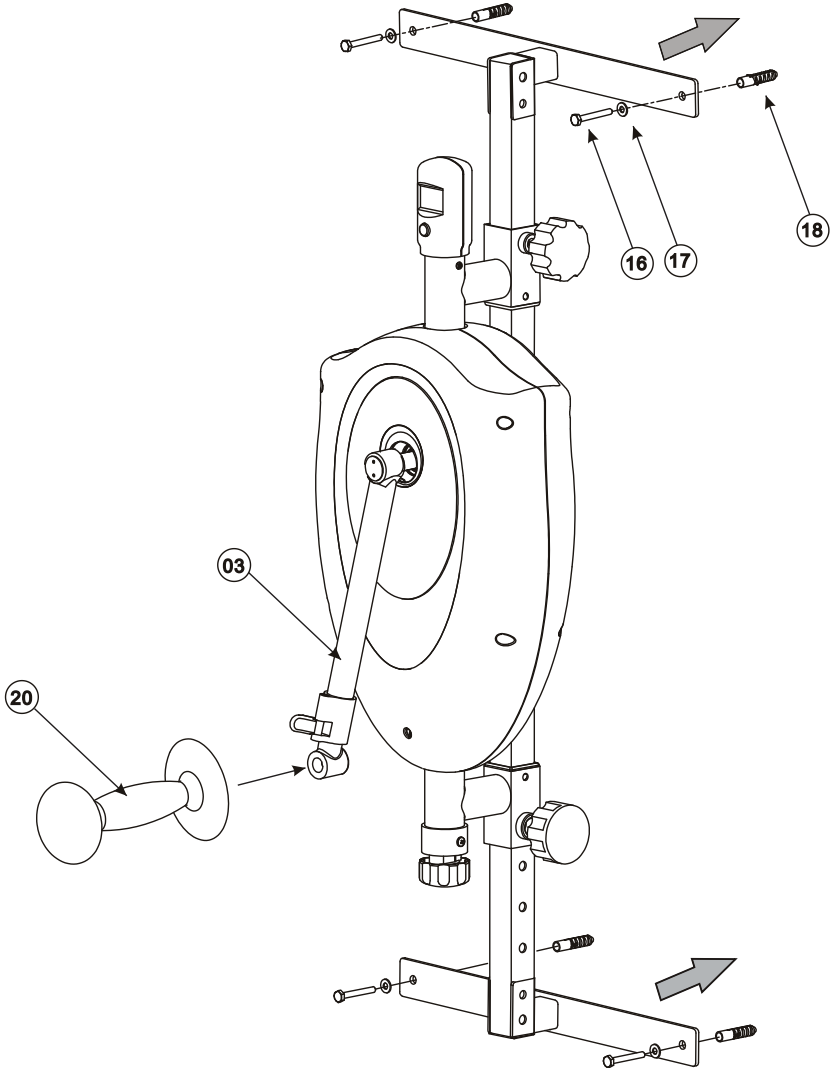

**PARTS LIST**

---

<b>NO.</b>	<b>DESCRIPTIONS</b>	<b>QTY</b>
01	Main Unit.....	1
02	Decoration Plate .....	2
03	Handle Bar .....	1
04	Electronic Monitor .....	1
05	Resistance Control Knob .....	1
06	Knob .....	1
07	Pop Knob .....	1
08	Upright Tube .....	1
10	Square Plug .....	2
11	Main Frame Mounting .....	2
19	Shaft Clamp .....	1
20	Hand Grip.....	1

## ASSEMBLY DIAGRAM

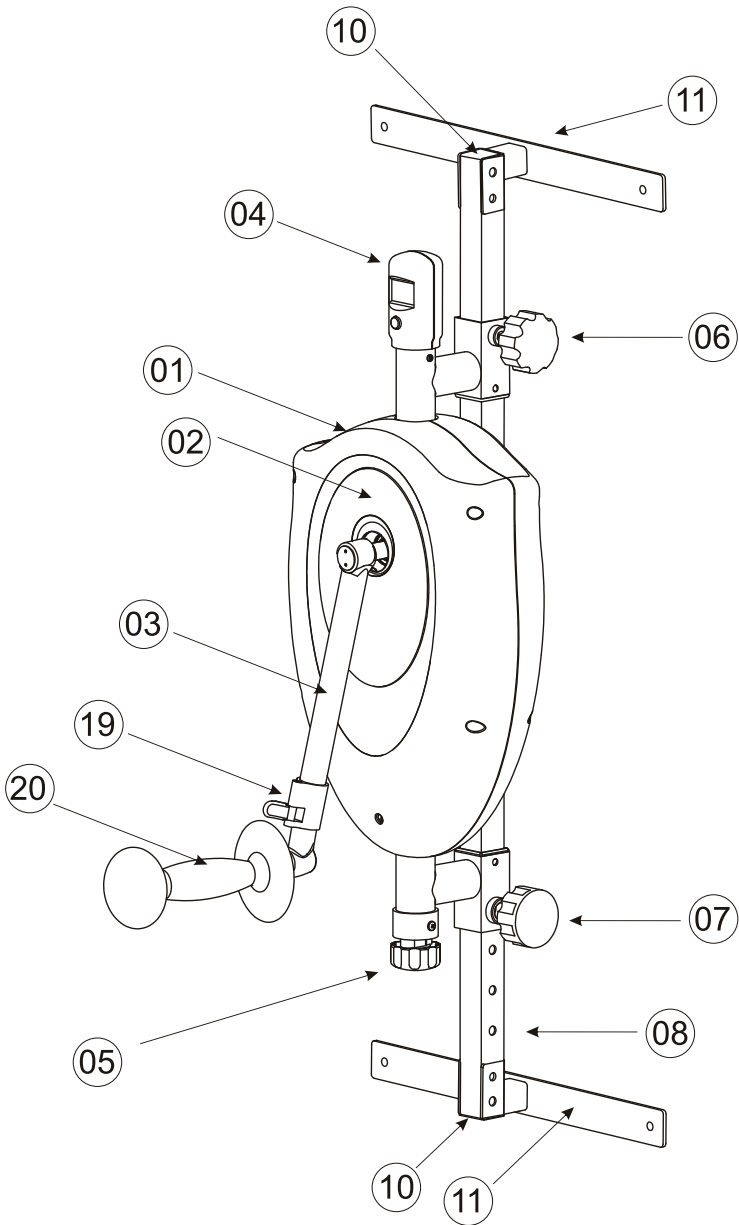

**ELECTRONIC MONITOR**



**FUNCTION “MODE” BUTTON**

Use “MODE” button to select functions: time, revolutions per minute, and total revolutions. Hold the “MODE” button for 2 seconds to reset all values.

**FUNCTIONS**

**SCAN**

Press “MODE” button to select “SCAN” mode with a “SCAN” sign on the upper left corner of the monitor. This function will automatically scan through all the functions displayed on the bottom line of the monitor.

**TIME**

Automatically accumulates workout time when starting exercise.

**REVOLUTIONS / MIN**

Displays current number of revolutions per minute.

**TOTAL REVOLUTIONS**

Displays number of revolutions completed during exercise session.

**STOP**

“STOP” displays on LCD when exercise ends.

**NOTE**

1. If an improper display is seen on the monitor replace the batteries.
2. Monitor uses two 1.5v “AA” batteries for power supply.
3. The monitor will automatically shut off if no input signal is received for a 4 to 5 minute period.
4. Monitor will automatically start when you start exercising or press the button.

## OPERATION INSTRUCTIONS



Hold the Hand Grip (#20 on page 9), then exercise clockwise or counter-clockwise.



Before using your **Shoulder Exerciser**, please adjust the height of the Main Unit to a proper height.

1. Main Unit Height Adjustment  
Loosen the Knob (#06) and Pop Knob (#07), then adjust the Main Unit up or down to your desire position, then fasten them.
2. Handle Bar Length Adjustment  
Pull up the Shaft Clamp (#19) to loosen the handle bar, then adjust the length to proper position, then push down to tighten it.
3. Resistance Control Knob (#05)  
This is to control the amount of resistance applied during exercise. Turn the Resistance Control Knob clockwise (+) for a more difficult workout, and counter clockwise (-) for a less difficult workout. It is recommended for a beginner to start the exercise from the lightest resistance to avoid injury. Gradually increase the resistance for increased difficulty.

