

M38e Carts

User Manual

For Models with Manual Lift



Elevating performance, every day.

Warnings



IMPORTANT – Indicates a situation that does not present any hazard but is very important in maintaining a well functioning workstation.



ATTENTION – Consult manual to avoid a potentially hazardous situation which may result in minor or moderate injury.



ELECTRICAL – Indicates an impending electrical hazard which, if not avoided, may result in personal injury, fire and/or death.



- The supplied power cord is rated for medical use. Connecting the cord to an outlet that is not medical grade (indicated with a green dot) will not ensure grounding protection.
 - Where the integrity of the external PROTECTIVE EARTH GROUND CONDUCTOR arrangement is in doubt, the equipment shall be operated from its internal electrical power source (battery).
 - Power cord, USB extension, and workstation are for INDOOR use only. **DO NOT OPERATE OUTDOORS.**
 - Keep power cord away from water. **DO NOT PLUG CORD INTO OUTLET IF WET.**
 - **DO NOT OPERATE PRODUCT IF WET.** If the WORKSTATION becomes wet, unplug it immediately, wipe off any excess liquid, and allow it to dry before using again.
 - Inspect power cord before integration. **DO NOT USE POWER CORD IF DAMAGED.**
 - Fully insert power cord plug into outlet. **DO NOT** unplug by pulling on cord. **DO NOT** remove, bend or modify any metal prongs or pins of power cord.
 - **DO NOT** use excessive force to make mechanical or electrical connections.
 - **DO NOT** obstruct the cooling vents.
 - **DO NOT** use an electrical extension cord with your workstation.
 - **DO NOT** use a flammable cleaner on the station as it can result in fire or explosion.
 - **DO NOT overload the cart. Weight of all customer installed technology not to exceed 30 lbs (13.6 kg). Weight of monitor not to exceed 15 lbs (6.8 kg).**
 - **DO NOT** operate the cart on an incline exceeding 10 degrees.
 - **DO NOT** use the cart to power equipment that is not part of the configured cart system.
 - **DO NOT** connect equipment that is not mounted on the cart into the power system outlets. The power system is designed for power cart mounted equipment only.
 - Equipment not suitable for use in the presence of a **FLAMMABLE ANESTHETIC FIXTURE WITH AIR, or WITH METERED OXYGEN OR NITROUS OXIDE.**
-  Do not adjust lift mechanism until cart has been outfitted with technology. Failure to do so may cause the shuttle and work surface to rise rapidly when actuator is released potentially causing personal injury or damage to the cart.
-  To avoid potential electrical shock, **DO NOT** simultaneously touch any cart system components and the patient or any apparatus not connected to the cart system. Electric current may try to flow through you between the M38e system and the other point of contact as it seeks the easiest path to ground.

Table of Contents

Warnings	3
Introduction	6
Box Contents	6
Specifications	7
Statement of Use.....	7
Overall View.....	8
Get Started	9
Install the Power Cord	9
Charge the Battery (Carts w/Power, Medpak Expansions).....	9
Setup	10
Setup Procedure	10
Remove the Work Surface.....	11
Install Keyboard and Mouse	12
Install the Monitor	13
Install a Thin Client or Closed Laptop.....	14
Install a Laptop Computer	15
Install the Work Surface.....	16
Adjust the manual Work Surface Lift Preload	17
Configure the control system (MedPak Expansion).....	18
Operation	19
Quick Start Procedure	19
Manual Work Surface Lift.....	20
Keyboard tray.....	20
Power on/Power off AC Powered Carts.....	21
Power on/Power off Non-Powered Carts.....	21
LCD User Interface (UI)	23
LCD Contrast	23
Keyboard Light	24
Mute Button	24
AC Power Expansion User Interface (UI)	25
Battery Charge Indicator.....	25
Drawer Modules	27
Casters.....	29
Bidirectional Work Surface.....	29

Maintenance	30
Remove and Replace the Battery	30
Remove and Replace the Input Power Fuses	31
Remove and Replace the Battery Power Fuse	31
Preventative Maintenance	32
Inspection Checklist	32
Troubleshooting	34
Service	35
Service Request	35
Service Level Commitment	35
M38e Accessories	35
Cleaning	36
Recommendations	36
Cleaning of High Touch Point Items	36
Warranty	38
Limited Warranty for M38e Computer Cart	38
Service Details	38
Transport/Storage/Disposal	38
Transport/Storage.....	38
Cart/Battery Disposal	38
Standards Compliance	39

Introduction

BOX CONTENTS

A

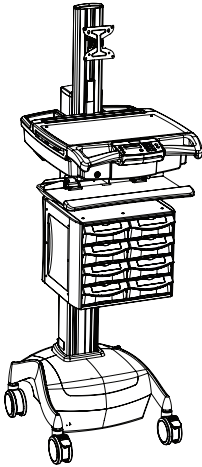

- A M38e Cart
- B Security Keys
- C Power Cord
- D M38e User Manual
- E Accessory Kit

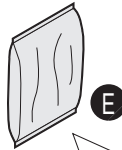
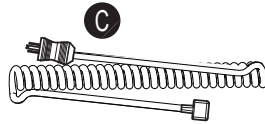

D

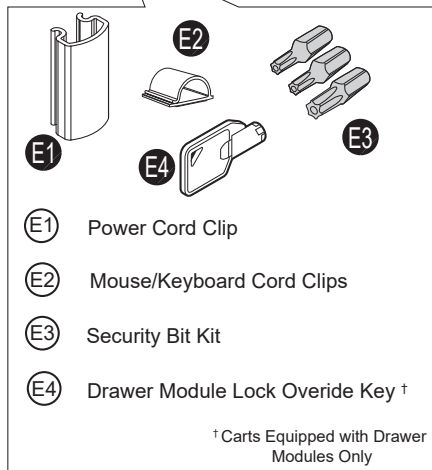

- E1 Power Cord Clip
- E2 Mouse/Keyboard Cord Clips
- E3 Security Bit Kit
- E4 Drawer Module Lock Override Key †

† Carts Equipped with Drawer Modules Only

Introduction

SPECIFICATIONS

Base Size	17" x 19" (43.2 cm x 48.3 cm)
Weight	Configurations starting at 100 lb (45.4 kg)
Height Adjustment	Up to 16" (40.6 cm)
Cart Height	49.3" to 65" (125.2 cm to 165.3 cm)
Keyboard Height	4.8" (12.2 cm) of vertical travel
Work Surface	17.25" W x 10.25" D (43.815 cm W x 26.035 cm D)
Casters	4" (10.2 cm) 2 locking 4" (10.2 cm) 2 locking; optional Tracking Caster 5" (12/7 cm) 2 locking; optional Tracking Caster
Keyboard Platform	Accommodates 1.75" H x 18" W x 8" D (4.5 cm x 45.7 cm x 20.3 cm) USB keyboard
CPU Cavity	17.0" x 11.25" x 3.0" (43.8 cm x 28.575 cm x 7.62 cm) 15.25" x 13.25" x 3.0" (38.735 cm x 33.655 cm x 7.62 cm)
LCD Monitor Mount	15 lbs (6.8 kg) max. 24" Monitor max.
Power Cord	2.5 ft (.75 m) hospital grade spiral cord – extends to 8 ft (2.4 m), recharges on board technology, 120/240 Vac, 6.3 A, 50/60 Hz
Power Strip	NEMA X3 Multiple Socket Outlet
UPS input	120 Vac, 5.1A (fused) North America 230 Vac, 2.5 A (fused) International Models
UPS output	120 Vac @1.25 A
Sealed Lead Acid (SLA) Battery	35 or 55 Ahr/12 V AGM (fused battery output) 12 Ahr (non-powered cart)
Lithium Battery	U1-12 Vdc @ 512 Wh (fused battery output)

STATEMENT OF USE

The M38e Mobile Computer Cart is designed and manufactured by Capsa Healthcare. Capsa Healthcare is dedicated to providing innovative quality products. Our goal is to increase the capacity to care by improving productivity, ergonomics and compliance while enhancing your facility image.

- The M38e Mobile Computer Cart is a mobile computing workstation cart designed for safe use in general patient areas for the purpose of clinical data entry and retrieval and medication delivery
- The M38e Mobile Computer Cart is not intended for home use
- The M38e Mobile Computer Cart has no potential electromagnetic or other interference risks when operated according to guidelines covered in this instruction manual

Introduction

OVERALL VIEW

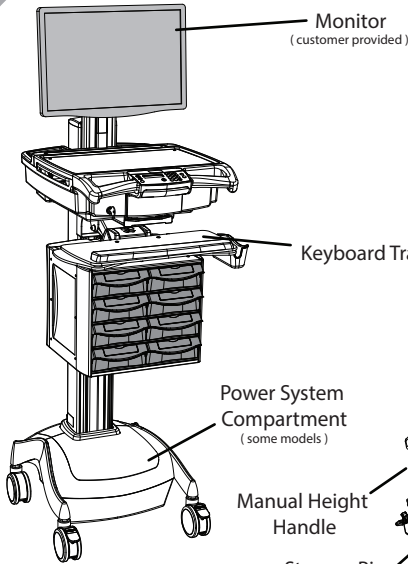

LCD Cart Configuration

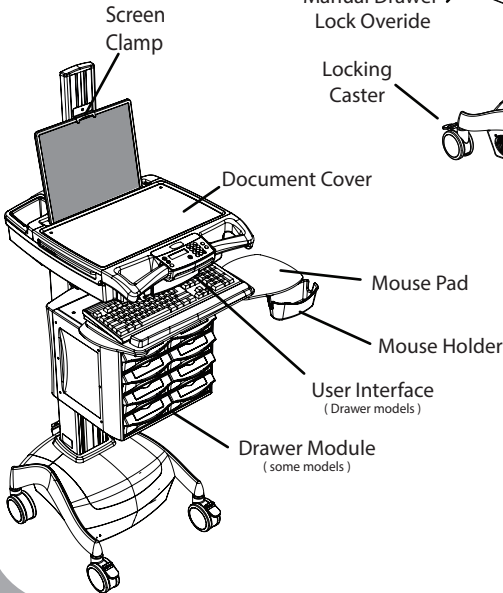
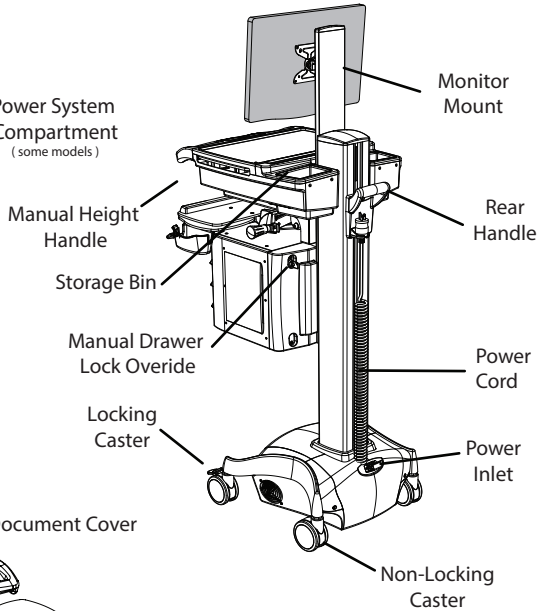

Laptop Cart Configuration

Get Started

INSTALL THE POWER CORD

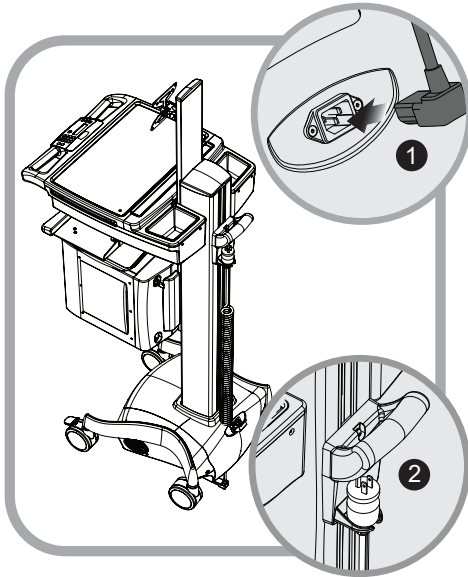

Install the power cord.

1. Plug the power cord into the power inlet as shown.
2. Place the plug in the cord holder.

Note: If the cart has a cord retainer clip installed, flex the front of the clip down and plug in the cord (3).

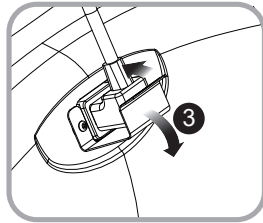

CHARGE THE BATTERY (CARTS W/POWER, MEDPAK EXPANSIONS)

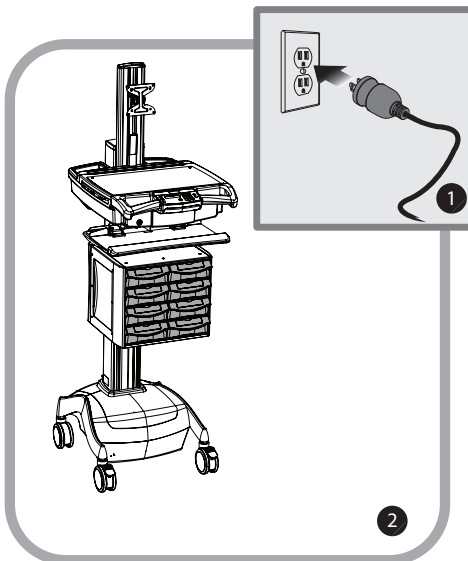

When carts configured with battery powered expansions are new, or have been removed from service for more than 30 days, the battery must be conditioned.

To condition the battery:

1. Plug in the power cord.
2. Leave the cart plugged in for approximately 8 hours.

Note: The initial (User Interface) UI charge indicator reading may be incorrect. Charge the cart for 8 hours to ensure that the battery is at full charge and that the charge indicator is set to the correct level of charge.

Setup

SETUP PROCEDURE

1. De-energize the M38e cart (refer to pages 21-22).
 2. Remove the storage bins.
 3. Remove the work surface.
 4. Install the keyboard and mouse.
 5. Install any technology devices.
 - Monitor
 - CPU or laptop
 - USB hub
 6. Test and Troubleshoot the installation
 - Make sure all connections are correct
 - Power the M38e cart
 - Start the technology devices and troubleshoot as necessary
 - Configure the technology devices to power on when the cart is powered on
 7. Configure the control system on models equipped with electronic controls.
 8. Replace the work surface and storage bins.
 9. Adjust lift mechanism preload on carts equipped with the manual surface lift.
- The M38e cart is now ready for use.



To fully shut down a non-powered cart:

1. Unplug the power cord.
2. Position the battery cut-off switch to the **Off** position.



Observe local safety procedure (e.g., lock out/tag out) to ensure that cart remains de-energized during maintenance and cleaning cycles.

Setup

REMOVE THE WORK SURFACE

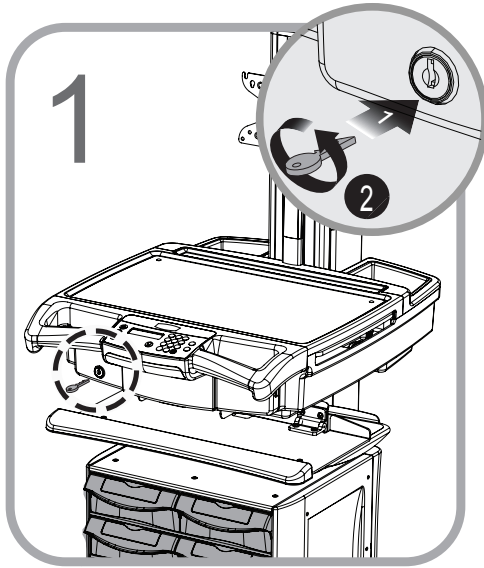

1. Insert the security key in the lock as shown.
2. Turn it counterclockwise to unlock the work surface.

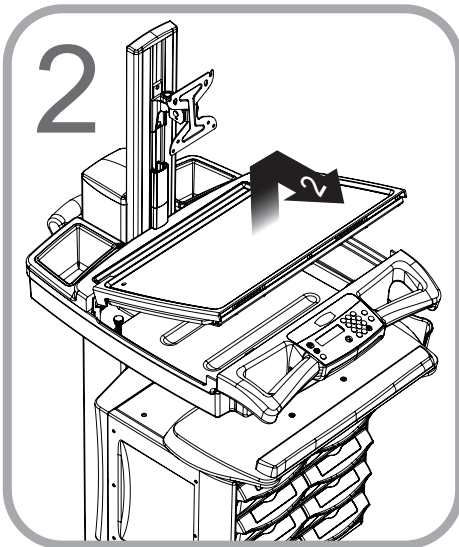

1. Lift the front of the work surface and pull it toward you.

Setup

INSTALL KEYBOARD AND MOUSE

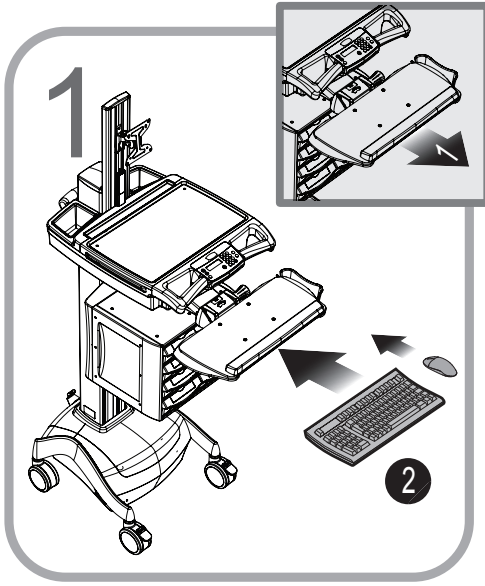

1. Grasp the front edge of the keyboard tray and pull it toward you to extend the keyboard tray.

2. Place the keyboard and mouse on the keyboard tray. Use self adhesive hook and loop material to keep the keyboard in position.

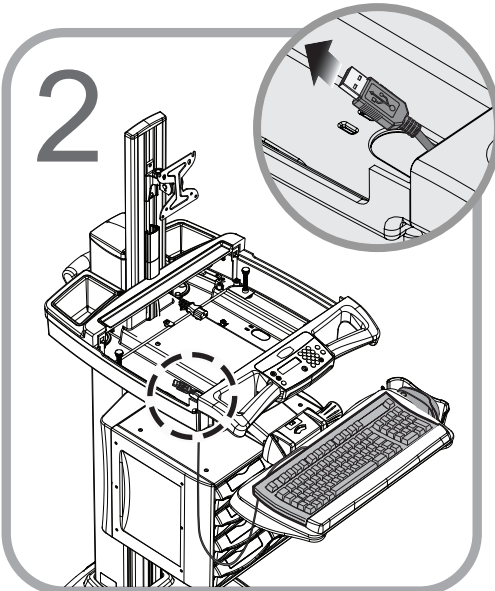

1. Route the keyboard and mouse cables through the front holes of the technology tray and under the laptop tray.

2. Secure the cables with cable ties using the smaller pass through holes provided.

Setup

INSTALL THE MONITOR

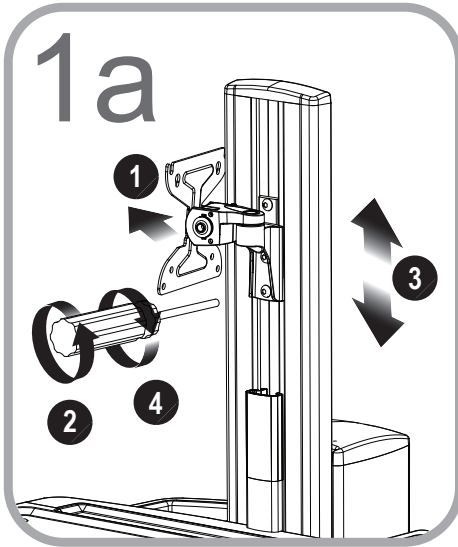

For pivoting monitor mount:

1. Pivot the mount head to allow access to the mounting holes. Assemble the mount to the T-Nut in the sliding track of the column with the screws provided.
2. To adjust the height of the mount, loosen the T-Nut screws.
3. Slide the T-Nut and the mount to the desired height on the column.
4. Tighten all of the screws to secure the mount into position. Use the mounting screws provided with the monitor to attach the monitor to the mount faceplate.

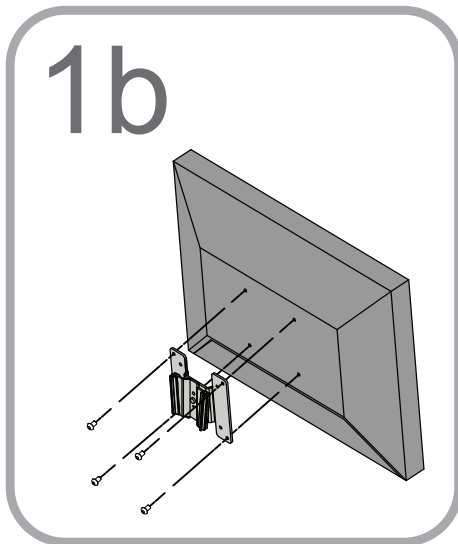

For non-pivoting monitor mount:

Use the mounting screws provided with the monitor to attach the monitor mount to the monitor.

Note: The mounting holes may need to be enlarged to accommodate the monitor mounting screws.

Note: If mounting screws are not provided along with the monitor, refer to the monitor documentation for the correct mounting screw size.

Note: It may be easier to connect the monitor cables while the monitor is off the M38e cart.

Setup

INSTALL THE MONITOR

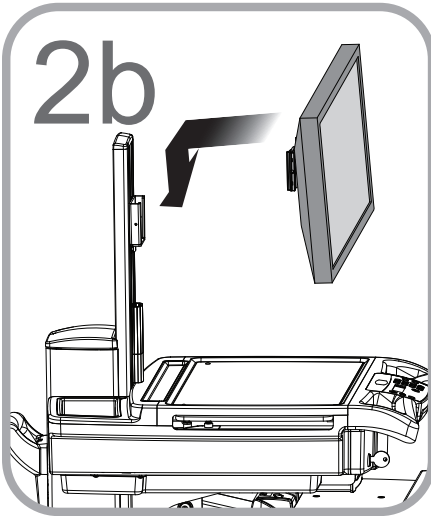

1. Insert the monitor/mount assembly onto the column mount.
2. Install the monitor cables if they haven't been already.
3. Route the cables to the technology tray.
4. Plug the power cord into the power strip.



Note: Ensure full movement of the monitor mount! To avoid damage to the monitor connections, verify there is enough cable slack to allow for full rotation of the mount and that accessories do not interfere with the range of motion.

INSTALL A THIN CLIENT OR CLOSED LAPTOP

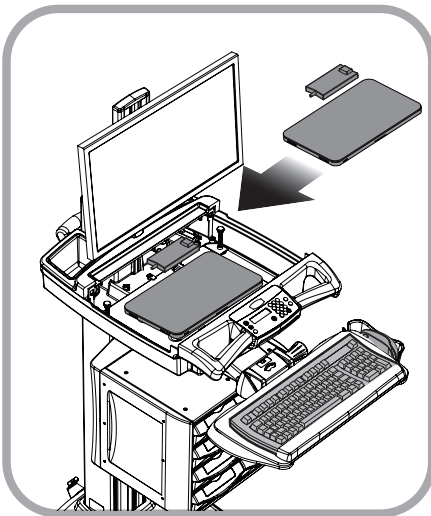

1. Place the laptop/thin client and power supply in the technology tray.
2. Connect the cables.
3. Plug the power cord into the power strip.

Note: To power the task light on an unpowered cart, plug in the black USB cable onto a powered USB port or hub.

Note: To monitor the power supply, connect the beige USB cable to the computer.

Note: A small form-factor computer may be mounted to the rear column. Contact Capsa Healthcare at: customer.service@CapsaHealthcare.com or 800-437-6633 for more information.

Setup

INSTALL A LAPTOP COMPUTER

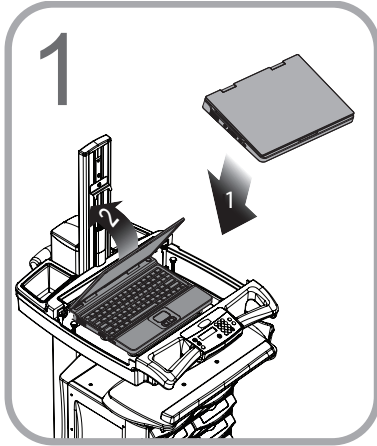

1. Place the laptop on the wire-form platform.

- Connect the cables to the laptop
- Plug the power supply into the power strip

Note: Use self-adhesive hook and loop material to anchor the laptop to the platform.

Note: to operate the task light on a non-powered cart, plug the black USB cable into a powered USB port or hub.

2. Open the laptop and rest the lid against the column.

Note: Use the thumb screws to raise the rear of the laptop platform so the bottom of the screen will be visible when the work surface is installed.

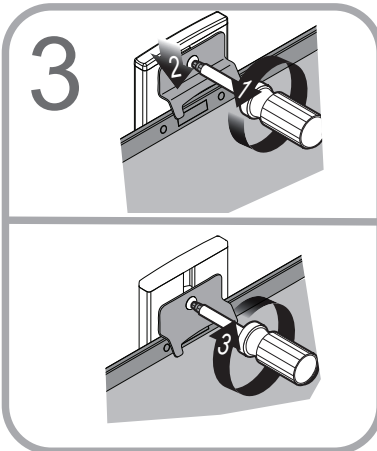
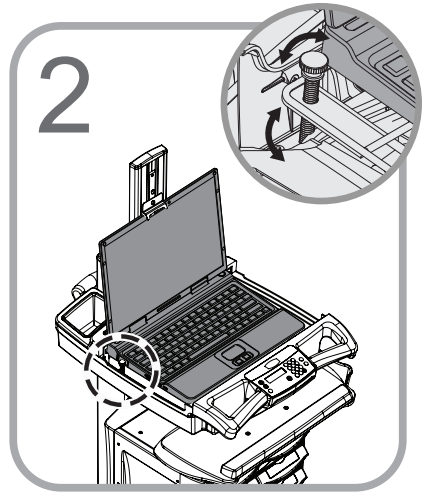

1. Loosen the monitor clamp screw.

2. Lower the monitor clamp until it contacts the top of the monitor as shown.

3. Tighten the monitor clamp screw.

Setup

INSTALL THE WORK SURFACE

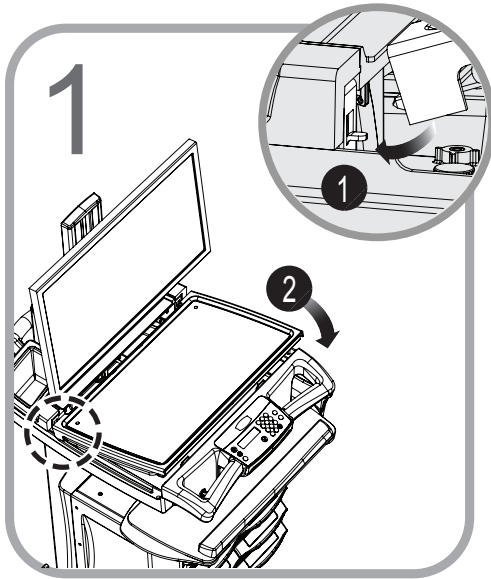

1. Align the work surface rear pins with the openings on the brackets of the technology tray as shown.
2. Lower the front of the work surface and engage the latches at the front of the technology tray.

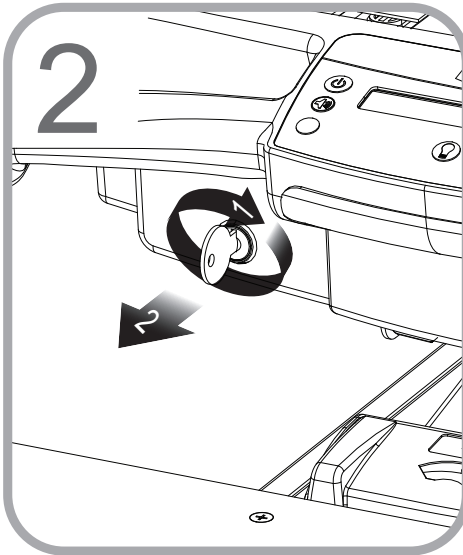

1. Turn the security key clockwise to lock the front latch.
2. Remove the security key.

Setup

ADJUST THE MANUAL WORK SURFACE LIFT PRELOAD

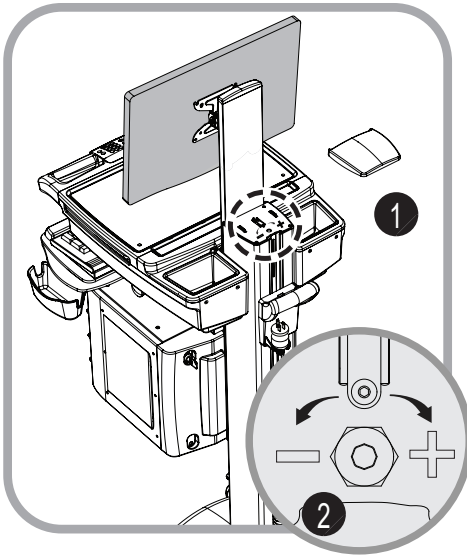

On models equipped with the manual work surface lift, it may be necessary to adjust the lift preload to compensate for the weight of the technology components added during setup.

Adjust the lift preload as follows:

1. Use a soft tool to pry and remove the column top cap (1).
 2. Use a 17mm (11/16) wrench to turn the adjusting screw (2) as necessary.
 - Turn the screw clockwise to increase the preload
 - Turn the screw counterclockwise to decrease the preload
 3. Raise and lower the work surface to test the adjustment
 4. Repeat steps 2-3 until the lift is adjusted
- Note:** The lift is adjusted when the work surface can be raised and lowered with approximately the same effort.
5. Replace the top cap (1).

Setup

CONFIGURE THE CONTROL SYSTEM (MEDPAK EXPANSION)

The electronic drawer control system offers a number of configurable advanced features which aid cart and fleet management.

Cart interface configuration software application and drivers are available for download at: www.capsahealthcare.com.

Control system features available for configuration are listed below:

Keyless Entry System PIN Number Management – The drawer control system stores up to 128 PIN numbers. PIN numbers control the locking mechanism for the storage and side mounted drawer modules.

Keyless Entry System Auditing – The drawer control system keeps a rolling log of PIN transactions listed by PIN number. Log data can be exported for off-line review.

Asset ID/Tagging – The **cart name** and **serial number** are provided for asset management. The **Serial** number is entered into the controller at manufacture and may only be viewed with the configuration software. The **cart name** is displayed on the LCD and is configurable with the software application.

Timers – The configuration software sets timers for the following:

- Drawer Lock-Down Time 1 - 255 seconds
- Keyboard Light Time-out 1 - 255 seconds
- LCD Backlight Time-out 1 - 99 seconds

Power Alert/Power Management Applications

The optional battery/power supply monitoring software application may be installed on the (customer supplied) installed computer. This software monitors battery usage and provides an indication of the current physical condition of the battery. The monitoring software also logs data log to either the installed computer or user's network depending on the configuration. The Power Alert/Power Management applications are available for download at: www.capsahealthcare.com.

Operation

QUICK START PROCEDURE

Good practice for starting the M38e cart is as follows:

1. Turn on the cart (refer to page 21).
2. Note the condition of the battery (the cart may need to be plugged in - refer to pages 25-26).
3. Move the cart to the desired location:
 - Unplug the cart from the wall outlet
 - Place the plug in the cord holder
 - Unlock the casters (refer to page 29)
 - Move the cart
4. Lock the casters.
5. Adjust the work surface height (refer page 20).
6. Enter Your PIN to unlock the drawers (refer to page 27).
7. Set work light as needed (refer to page 24).
8. When you finish your work cycle return the cart and plug it in to charge.

Note: Plug the cart into an electrical outlet where it will be left unattended for a length of time.

Operation

MANUAL WORK SURFACE LIFT

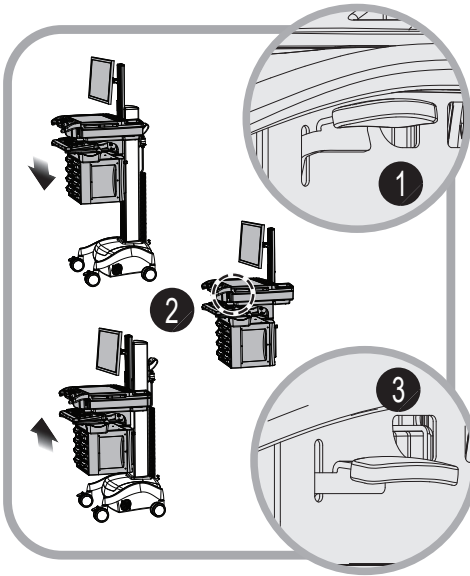

To raise or lower the work surface:

1. Position your hands to hold the work surface steady.
2. Lift the height lever located beneath the right handle.
3. Raise or lower the work surface to the desired height.
4. Release the height lever and slightly raise or lower the work surface to make sure the locking pin is seated. (You will feel the locking pin detent and lock in position if it is not seated.)

KEYBOARD TRAY

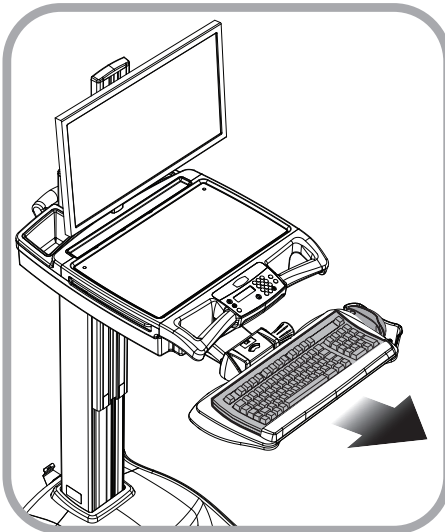

To extend the keyboard tray, pull the key board tray toward you until it stops.

To retract the keyboard tray, push in on the keyboard tray until it stops.

To extend the mouse pads, grasp the top edge and rotate them outward (down) into the open position.

To retract the mouse pads, grasp the bottom edge and rotate them inward (up) to the closed position.

Operation

POWER ON/POWER OFF AC POWERED CARTS

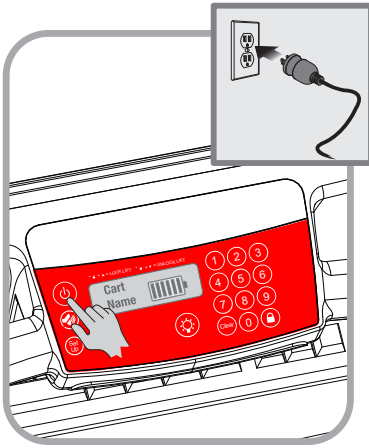

To turn on AC powered carts:

1. Plug in the power cord.
2. Press and hold the **Power** button  for 3-5 seconds.

Note: The UI displays the battery condition and the keypad will function.

Note: Plug the cart into an electrical outlet when it will be left unattended for any length of time.

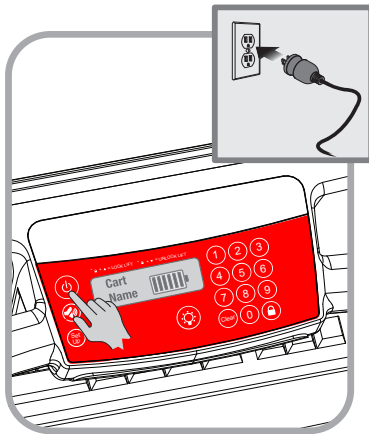

To turn off AC powered carts:

1. Unplug in the power cord, and place it in the cord holder.
2. Press and hold the **Power** button  for 3-5 seconds.

The UI goes dark or blank and the keypad will not function. Cart power to all devices plugged into the cart power system is turned off.

The cart is electrically de-energized for cleaning or maintenance.

Operation

POWER ON/POWER OFF NON-POWERED CARTS

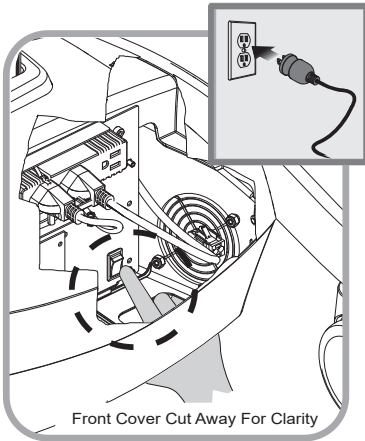

To turn on non-powered carts:

Note: The **Power** button  is not used by the non-powered control system. The battery cutoff switch is the power switch.

1. Turn on the battery cutoff switch as shown.
2. Plug in the power cord.

The UI will display the battery condition and the keypad will function.

Note: Plug the cart into an electrical outlet where it will be left unattended for a length of time.

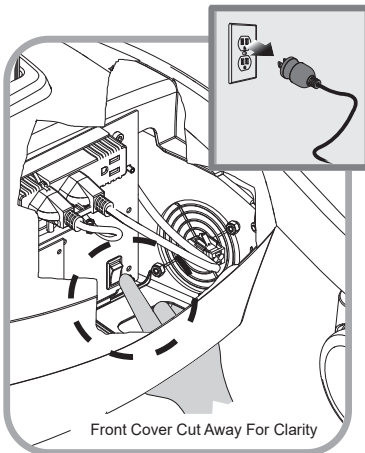

To turn off non-powered carts:

1. Unplug in the power cord.
2. Turn off the battery cutoff switch as shown.

The UI goes dark or blank and the keypad will not function. Cart power to all devices plugged into the cart power system is turned off.

The cart is now electrically de-energized cleaning or maintenance.

Note: The M38e cart should only be powered off for the following conditions:

- The audible alarm cannot be muted
- When the cart will not be used for an extended period (the cart is placed in storage)
- For maintenance
- If the cart is moved to a different facility

Operation

LCD USER INTERFACE (UI)

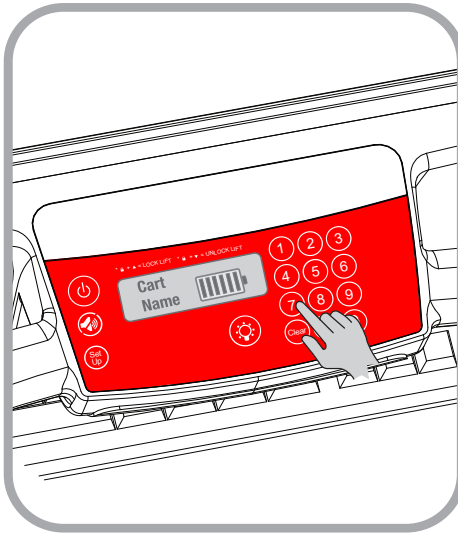

Powered and non-powered carts configured with the electronic locking drawer expansion module are equipped with the User Interface (UI). The UI controls the low battery alarm, keyboard light, drawer control system, power supply and PIN entry to unlock the drawers.

Depending on the cart power configuration, use one of two methods to power on/power off the cart:

- For AC powered carts, see page 21.
- For non-powered carts, see page 22.

LCD CONTRAST

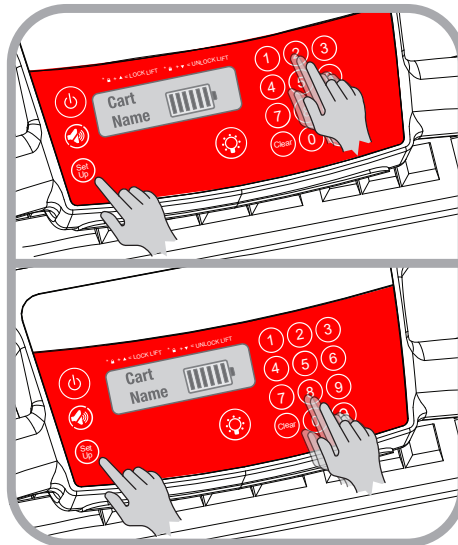

The LCD level of contrast is adjusted as follows:

To increase the contrast:

1. Press and hold down the **Setup**  key.
2. Repeatedly press the **2** key (the up arrow) until the display shows the desired level of contrast.

To decrease the contrast:

1. Press and hold down the **Setup** key.
2. Repeatedly press the **8** key (the down arrow) until the display shows the desired level of contrast.

Operation

KEYBOARD LIGHT

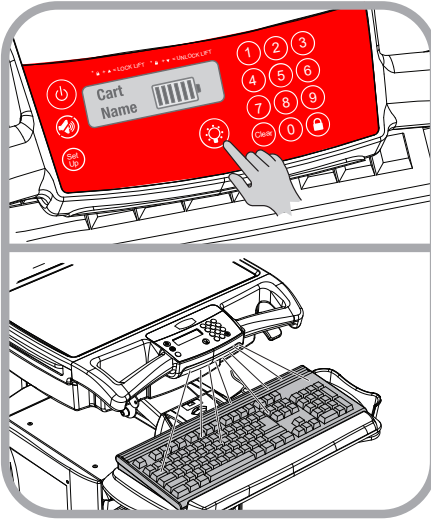

A keyboard light is included to enhance cart usability in darkened patient areas. The keyboard light that is operated by using the **Light** button located on the membrane keypad at the front of the cart.

The keyboard light is designed to illuminate the keyboard in the extended position. When the keyboard tray is retracted, the keyboard light will illuminate the floor in front of the cart.

To use the keyboard light:

- Press the **Light** button  to turn on the keyboard light.
- Press the **Light** button again to turn off the keyboard light.

Note: The keyboard light will turn off automatically when the keyboard light timer counts down to zero.

MUTE BUTTON

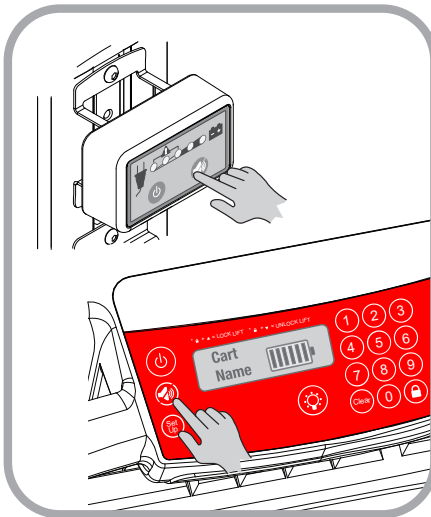

The **Mute** button  is used to silence the power system audible alarm.

To mute the audible alarm, press and hold down the **Mute** button  until the alarm is silenced.

Note: When the battery is at 10% (1/8) charge or less, the audible alarm will sound again after a minute when the mute button is used until the power system is turned off or the cart is plugged in to charge the battery. Failure to plug in or turn off the power system will damage the battery.

Note: Do not allow the battery charge to drop below 20%, the battery may lose the ability to recharge.

Operation

AC POWER EXPANSION USER INTERFACE (UI)

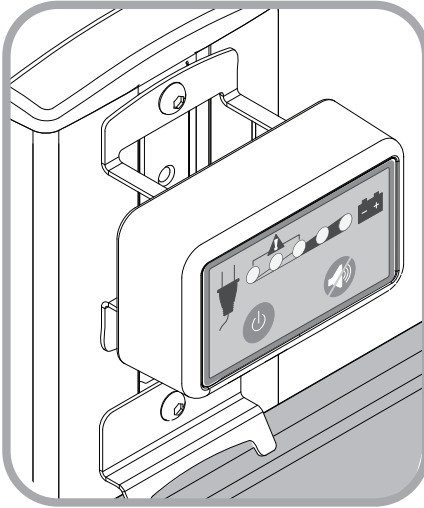

The LED UI is included on M38e computer carts configured with the AC power expansion but without drawer expansions. The LED UI controls the AC power supply and monitors the condition of the cart power battery.

Power Indicator The left hand LED is the power indicator. If the light is green, there is AC power to the installed technology devices.

Battery Charge Indicator The other four LEDs are designated for the battery charge level. Each LED indicates roughly 25% charge. The battery indicator is further explained below.

BATTERY CHARGE INDICATOR

M38e cart power expansions are equipped with a battery gauge that displays the level of battery charge. Powered carts without powered drawer expansions are equipped with LED battery gauges. The UI for powered carts equipped with powered drawer expansions has an LCD battery gauge.

The UI also indicates power system status:

Normal	> 50% to 100%	The cart may be unplugged and used on battery power.
Charge Mode	< 50% to 20%	The cart should be plugged in to charge but may be used on battery power alone. The audible alarm will sound but may be muted.
Recovery	< 20%	The cart must be plugged in. The cart may shutdown for deep discharge recovery cycle and should remain plugged in for 6-8 hours. Powered components will not be available during this period. The audible alarm will continue to sound. When the battery level drops below 10% the alarm cannot be muted unless the cart is plugged in.



Caution: Never allow battery charge level to drop below 20%. Failure to keep the battery charge greater than 20% may damage the battery and render it unable to recharge.

Operation

Powered Drawer Expansion LCD User Interface

The LCD displays a graphic battery gauge. The interior of the battery graphic displays 6 bars to indicate charge level.

Charging - The indicator bars scroll to indicate charging

Recovery - The LCD will darken

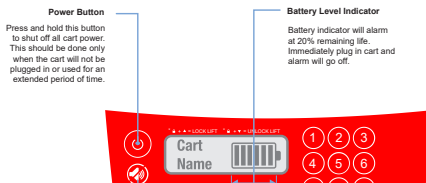

The condition of the battery gauge bars and audible alarm for corresponding levels of battery charge are listed in the table below.

>83%-100%	On	On	On	On	On	On	Off
>65%-83%	On	On	On	On	On	Off	Off
>49%-65%	On	On	On	On	Off	Off	Off
>33%-49%	On	On	On	Off	Off	Off	On
>16%-33%	On	On	Off	Off	Off	Off	On
>0%-16%	On	Off	Off	Off	Off	Off	On

Operation

DRAWER MODULES

Drawer Locks

The drawers are accessible when a valid personal identification number (PIN) is entered into the controller. A user may lock the drawers by either pressing the **Lock**  button or by waiting until the drawer lock timer counts down. The electronic drawer lock will not function when the battery is dead, conditioning, or if the cart is electrically de-energized. When there is no power to the drawer module, open the drawers by using the manual lock override that is located at the rear of the drawer module.

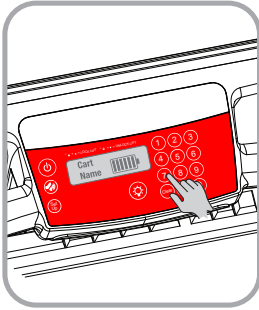

Enter A PIN

Press the number keys (1-0) to enter the 4 digit PIN code.

Note: The factory default PIN is **8034**.

As you enter digits a ***** symbol is displayed to indicate that a digit has been entered into the controller.

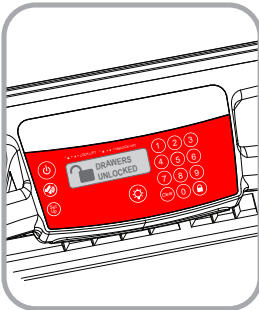
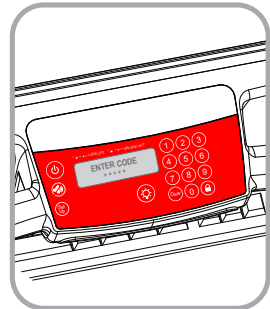

If the 4 digits entered are a valid PIN, the drawer module will unlock and the **Drawers Unlocked** message will be displayed.

If the digits are not a valid PIN, the **Error Invalid Code** message is displayed for a short time, then the displays changes to the battery monitor.

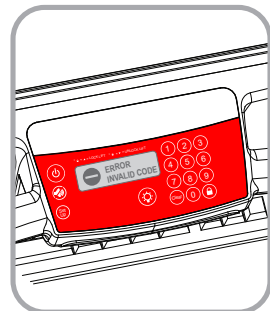

Operation

DRAWER MODULES

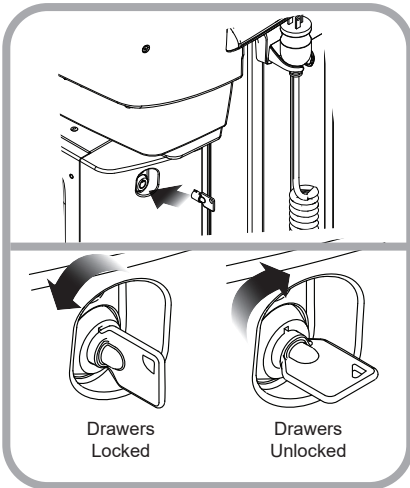

Manual Drawer Lock

Use the manual drawer lock override as follows:

1. Insert the lock override key into the lock located on the rear of the drawer module.
2. Turn the key clockwise to open the drawers.
The key cannot be removed while the drawers are unlocked.
3. Turn the key counterclockwise to lock the drawers and remove the key.
The drawers are locked, the key may be removed from the lock.

Drawer Labeling

Drawers are equipped with a dual labeling system that is located on the drawer pull. There are Wet-erase labels located beneath the clear label guard (white for locking drawers, gray for non-locking). Also, the label guard forms a pocket which accepts a 4 1/8" (10.5 cm) X 7/8" (2.2 cm) paper or card label.

Label the drawers in the following manner:

Wet-erase labels

1. Remove the clear plastic label guard.
2. Use a wet erase marker (Expo® Vis-a-vis® or equivalent) to label the drawer.
3. Replace the label guard.

Paper labels

1. Cut out and print a sufficient number of 4 1/8" X 7/8" labels.
2. Insert the label between the label guard and the dry erase surface.

Operation

CASTERS

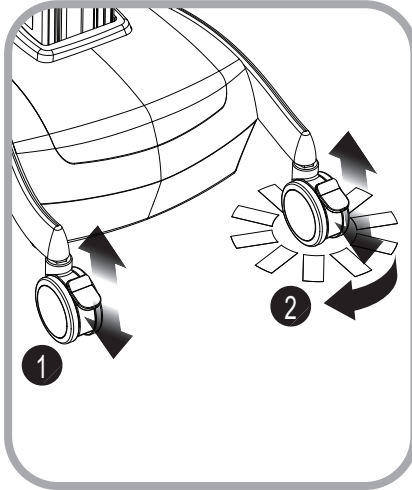

To operate braking casters:

1. Lower the tab with your toe to lock a caster.
2. Lift the tab with your toe to unlock a caster.

To operate tracking casters:

1. Lower the tab with your toe to engage tracking feature.

Note: When the tab is lowered, the tracking caster will align to the nearest angle position.

2. Lift the tab with your toe to disengage the tracking feature.

BIDIRECTIONAL WORK SURFACE

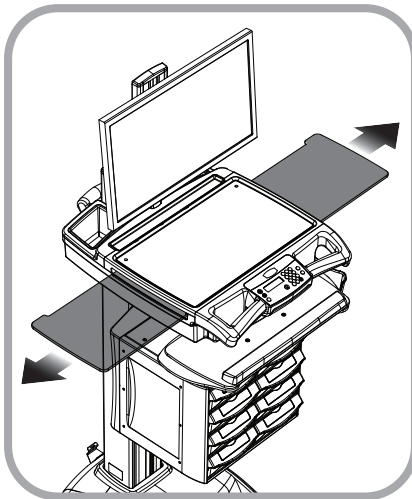

To extend the bidirectional work surface:

- Pull the end of the bidirectional work surface in the desired direction.

Note: You may have to push the opposite end of the work surface into the tech box in order to get a hand hold.

To Retract the bidirectional work surface:

- Push the exposed end of the bidirectional work surface until it is flush with the side of the tech box.

Maintenance

REMOVE AND REPLACE THE BATTERY

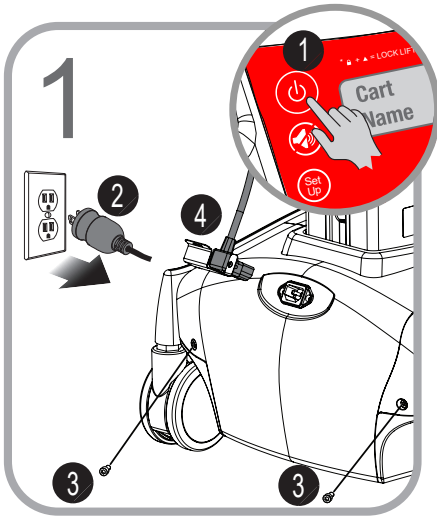

Shut down the M38e cart and remove the rear cover:

1. Unplug the M38e cart from the wall outlet.
2. Press and hold down the **Power** button (1) for approximately 2 seconds to turn off the M38e cart.
3. Remove the power cord (2) from the rear of the M38e cart.

Note: If cart is equipped with cord retaining clip, remove 2 screws and cord retaining clip.

4. Use a 4mm hex key wrench to remove 2 screws (3) and battery cover (4) from the rear of the M38e cart.

Reverse these steps to replace the rear cover and power cord.

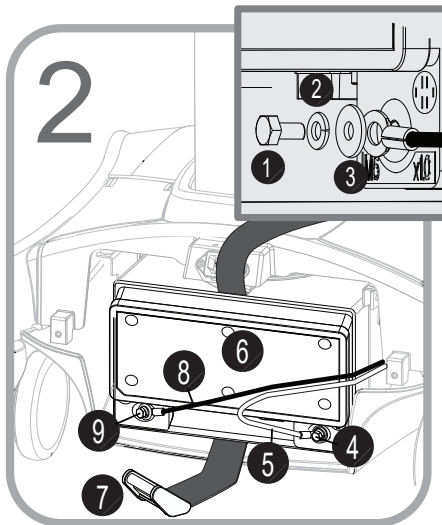

Remove the battery:

1. Unbuckle the web belt (7).
2. Remove bolt (1), lock washer (2), washer (3), and **Red** cable (5) from positive battery terminal (4).
3. Remove bolt (1), lock washer (2), washer (3), and **Black** cable (8) from negative battery terminal (9).
4. Remove battery (6) from the M38e cart.

Reverse these steps to install the battery.

Maintenance

REMOVE AND REPLACE THE INPUT POWER FUSES

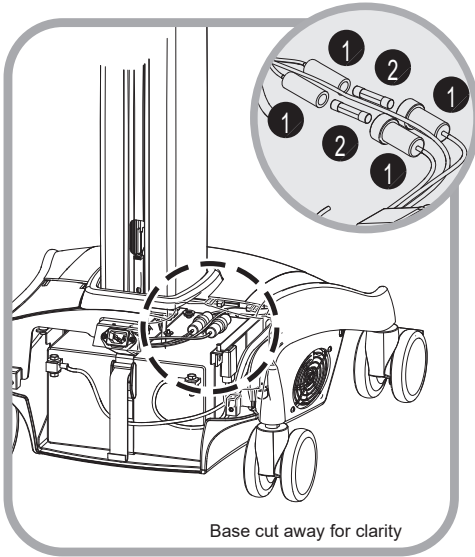

Shut down the M38e cart, remove the rear cover, remove the battery, remove and replace the fuses:

1. Power down the M38e cart and remove the rear cover as directed on page 30 of this manual.
2. Remove the battery as directed on page 30 of this manual.
3. Twist open fuse holders (1) and remove fuses (2). Discard blown fuses.

Replace fuses with Eaton Bussmann® AGC-6 or equivalent.

Reverse the order of these steps to reassemble the cart.

REMOVE AND REPLACE THE BATTERY POWER FUSE

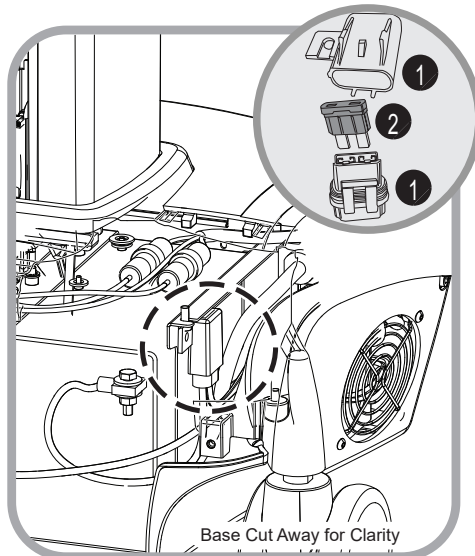

Shut down the M38e cart, remove the rear cover, remove and replace the battery fuse:

1. Power down the M38e cart and remove the rear cover as directed on page 30 of this manual.
2. Remove the lower half of battery fuse holder (1) as shown.
3. Remove fuse (2). Discard the blown fuse.

Replace fuse with Littelfuse® ATOF # 0287030 30A or equivalent.

Reverse the order of these steps to reassemble the cart.

Preventative Maintenance

INSPECTION CHECKLIST

To protect optimal performance, Capsa Healthcare recommends a periodic inspection and preventative maintenance of your computing cart fleet. These simple steps can safeguard against breakdowns and help you realize uninterrupted workflow and cart availability.

Items	Action	Benefit
Power supply	Check voltage and current output to original power supply specifications. Inspect fan and airflow for dust and lint buildup.	Helps prevent unexpected power failures and ensures proper airflow to power system for cooling.
AC power cord, fuses, and internal cables assemblies	Inspect wires and components for any damage; ensure there are no loose connectors.	Identifies potential safety issues, extends life of battery, ensures consistent recharging and optimizes workstation runtime.
Battery	Check if battery voltage is within normal operating range. Check battery cable connectors for correct tightness; terminals are free of corrosion.	Extends life of battery and supports consistent performance.
Casters	Check casters for proper tightness, ensure casters are free of dirt and grime and operate smoothly.	Mitigates risk of injury due to loose casters. Ensures proper maneuverability of workstation.
Inspect base covers and hardware	Check for loose or broken covers.	Ensures proper airflow and power system cooling. Prevents unexpected power failure; mitigates chance for interrupted workflow and clinical processes.
Inspect keyboard tray movement	Check range of keyboard tray for full field of motion and stability.	Proper adjustment supports ergonomic capability that meets unique requirements of multiple users.
Inspect work surface area	Inspect work surface for cleanness and damage.	Promotes proper infection control practices and maintains protected area for internal electrical components.

Preventative Maintenance

INSPECTION CHECKLIST

Items	Action	Benefit
Inspect height adjustment, electrical or manual	Check height adjustment for proper function, including full range of motion.	Facilitates simple height and ergonomic adjustments; ensures comfortable use by clinical staff.
Inspect keyboard light	Check all lighting and switch operation; confirm lights function properly.	Supports proper lighting for reading, work surface tasks, and safe cart maneuvering in low light environments.
Inspect User Interface (including storage module functions)	Check proper functionality of all cart controls.	Functional controls allow users the full benefit of the cart features and capabilities.
Inspect all bins and drawers	Check functionality of bins and drawers including locking function.	Smooth operation of bins and drawers provides secure, organized storage.
Inspect mounted accessories	Check for secure fit to mount area and tighten if necessary.	Ensure stable accommodation of peripheral device holders and other accessories and supplies.

Troubleshooting

Problem	Solution
Cart Will Not Power Up	Plug the power cord into a working hospital grade outlet.
	Verify the power cord is securely plugged into the back of the cart.
	Check to see if the Power System Interface (PSI) is charging when it is plugged in.
	If the charge level is critically low (20% or less) allow the cart to fully charge.
	If the cart does not start, verify the PSI cables are seated properly.
Cart Will Not Charge	Verify the external spiral cord is plugged into the base of the cart.
	Ensure outlet is functioning properly.
	Plug the power cord into a working hospital grade outlet.
	Verify the power cord is securely plugged into the back of the cart.
	Check to see if the PSI indicates the station is charging when plugged in.
	If the charge level is critically low (20% or less) allow the cart to fully charge.
	If the cart still does not charge, verify the PSI are seated properly.
Audible Alarm Will Not Turn Off	When the battery capacity remaining reaches approximately 10%, the audible alarm will sound. The alarm may be muted for 1 minute. Until the cart is plugged in to charge, the audible alarm will continue to sound every minute.
	If the alarm fails to sound after plugging in the cart for several minutes, power down the unit by holding the On/Off button for 2  seconds.
Cart Is Hard To Push	Verify the caster locks are in the unlocked (up) position.
	Examine the casters for any foreign debris.
Keyboard Tray Will Not Raise or Lower	Inspect for cable obstructions.
	Adjust the keyboard arm tray knob counterclockwise to loosen.
	Adjust the keyboard arm tray knob clockwise to tighten.
Keyboard Light Does Not Work for Non-Powered Version	Make sure the USB cable is plugged into the laptop.
Keyboard Light Does Not Work for Powered Cart	Verify the powered USB hub is plugged into the power supply (green light indicator).
	Ensure the USB cable is plugged into the hub.

Troubleshooting

Problem	Solution
Mouse Does Not Work Properly (Powered Cart Only)	Verify the powered USB hub is plugged into the power supply (green light indicator).
	Make sure the mouse is plugged into the USB hub.
	If the problem persists, plug the device into another cart to see if it functions properly.
Keyboard Does Not Work Properly	Ensure the USB hub is powered and plugged into the power supply (green light indicator).
	Make sure the keyboard is plugged into the USB hub.
	If the problem persists, plug the device into another cart to see if it functions properly.
Computer Does Not Work Properly	Check that computer has power.
	Check the battery charge. If it is less than 20%, recharge the battery.
	If problem persists, plug device into another cart to see if it functions properly.

Service

SERVICE REQUEST

Contact your IT department, or file a service request at our website: www.capsahealthcare.com.

SERVICE LEVEL COMMITMENT

Capsa Healthcare is committed to providing best-in-class service. This document details our standard warranty and instructions for requesting service using our customer support system.

Capsa Healthcare will provide a service manual upon request.

Cleaning



CAUTION: Due to the close proximity of electrical power and equipment, flammable cleaners should never be used on the cart!

- Verify that your cart is powered down and unplugged from the wall outlet before cleaning
- Allow your cart to dry completely before plugging the power cord into a wall outlet
- When cleaning the cart, wipe off the surface with a damp cloth and thoroughly dry
- Never immerse the cart or its components in liquid or allow liquids to flow into the cart
- Never use steel wool or other abrasive materials as these could damage the surface finish
- Before using any cleaner on the cart, first test it on a small area to ensure that the surface is not harmed
- These guidelines cannot guarantee infection control. The hospital's Infection Control administrator should be consulted for cleaning procedures and processes.

RECOMMENDATIONS

- Clean plastic components with diluted, non-abrasive solutions. Suggested cleaners are: water, soap, diluted bleach and alcohol solutions.
- Remove pen and dry erase marker stains with a soft cloth and 91% isopropyl alcohol
- Remove iodine stains with a soft cloth and any of the cleaners suggested above
- DO NOT use the following chemicals to clean your cart: acetone, mineral spirits, abrasive cleansers, paint thinner or any other harsh or toxic chemicals

CLEANING OF HIGH TOUCH POINT ITEMS

- The work surface is fully removable to facilitate cleaning.
- The document protector is removable (pull up on the back corners). To refasten, press the nylon fastener into the hole in the work surface. This is a replaceable item.
- The back handle is fully removable.
- Rear bins can be removed by grabbing the outside edge of the bin and lifting up.
- The keyboard tray and mouse pads are composed of melamine resin and are easy to wipe down.

Warranty

LIMITED WARRANTY FOR M38E COMPUTER CART

Capsa Healthcare is pleased to offer a three-year warranty on durable components and a three-year warranty on electronic components.

If, during the warranty period, this Capsa Healthcare product proves defective in materials or workmanship under normal use by the original purchaser, please contact Capsa Healthcare technical support (please be ready to furnish complete information, including the product serial number, description of the issue and full contact information). Capsa Healthcare will determine, at its sole discretion, how to best address your warranty issue, which may include sending you a replacement part covered under warranty or for sale. Capsa Healthcare reserves the right to require proof of purchase prior to honoring any warranty request. This warranty does not cover product abuse, improper or lack of maintenance or cleaning, modification, integration with third party products, improper storage, failure to adhere to product instructions, improper operation or misuse. Examples of misuse include, but are not limited to: improper battery charging / discharging behavior, over stuffing of drawers and side bins, use of sharp objects on user interface screens or keypads, improper handling of and over stressing power cords, spilling liquids on product or exposure to harsh elements including temperatures and moisture outside the operating and storage specifications. CAPSA HEALTHCARE SHALL NOT BE LIABLE FOR ANY CONSEQUENTIAL OR INCIDENTAL DAMAGES WHATSOEVER. Some states do not allow the exclusion or limitation of incidental or consequential damages, so the above limitation or exclusion may not apply to you. This warranty gives you specific legal rights and you may also have other rights which vary from state to state or country to country. Components that generally do not warrant onsite technical assistance include, but are not limited to: storage bins, power cords, drawers and battery replacement. Components that are not covered under this warranty include, but are not limited to: post cart manufacturing installed accessories, document protectors, wrist rests and any customer or third party provided items. Preventative maintenance is necessary and recommended once per year for proper function and safety. Examples of preventative maintenance include, but not limited to: the removal of dust and lint from the power system, inspecting and tightening casters. Preventative maintenance is the sole responsibility of the customer unless this service is purchased separately from Capsa Healthcare. Battery performance warranties are different from product warranty and are based on battery type. Capsa Healthcare will determine, in its sole discretion, how to best address your warranty issue, which may include any one or combination of the following: phone support, sending you a replacement part, or providing on-site technical assistance. When Capsa Healthcare provides on-site services, the customer will provide access to the product with minimum wait time. The customer is required to return all parts at the request of Capsa Healthcare.

SERVICE DETAILS

Consumable components are not covered under warranty and include:

- Locks and keys
- Document cover

Other standard components will be replaced under the applicable warranty following a filed service request.

*The above terms for replacement parts applies to facilities located in the United States. All other customers should contact the appropriate reseller for the terms of part replacement.

All terms are subject to change without notice.

Transport/Storage/Disposal

TRANSPORT/STORAGE

- The shipping weight of the M38e cart is approximately 105-160 lbs (50-72 kg). Use proper lifting techniques to prevent injury.
- Care should be taken to transport and store this system within a temperature range of 32° F to 90° F (0° C to 32° C); humidity 20% RH to 95% RH non-condensing

CART/BATTERY DISPOSAL

Battery Disposal/Recycling

Dispose/Recycle Lithium and SLA batteries according to local guidelines and regulations for disposal/recycling of batteries.

Cart Disposal

Dispose of this cart according to local guidelines and regulations for disposal of electronic equipment.

Standards Compliance

TEST COMPLIANCE:

NRTL

- UL 60601-1:2003
- CAN/CSA-C22.2 No.601.1-M90
- IEC 60601-1/A2:1995
- EN 60602-1/A2:1995
Standard for Safety Medical Electrical Equipment, Part 1: General Requirements for Safety - Collateral Standard: Safety Requirements for Medical Electrical Systems

FCC

PART 15, Subpart B, Class A – Unintentional Radiators

PRODUCT CLASSIFICATION:

- Class 1/ Internally powered device with no applied parts
- This equipment is designed for continuous operation
- Class A, Group 1 ISM Equipment
- This device is classified IPX0 for water ingress
- Input 120 Vac, 60 Hz, 5.1 Amp North America
- Input 230 Vac, 50 Hz, 2.5 A International Models



