

# SpiroCare Operation Manual



**Ver. 1.13**

2020.07.14



## Warranty

- This product was made through strict quality control and examination.
- The warranty for this product runs for 3 years. The warranty for accessories runs for 90 days.
- When having troubles during this period, please provide us with the model name, serial number, date of purchase and a description of the problem you are experiencing.

### - Indications for Use

The SpiroCare Spirometer is intended for prescription use only to conduct diagnostic spirometry testing of adults and pediatric patients in general practice, speciality physician, and hospital settings.

Caution
Federal law restricts this device to sale by or on the order of a physician

## Fee-Based Service

**If you wish to make a claim when the product is damaged through misuse, we charge repair fees. Please read the manual before you make a claim.**

<ul style="list-style-type: none"> <li>- For simple inspection without giving instruction or disassembling the product</li> <li>- For reinstalling due to poor installation by the retailer</li> </ul>	<p>Fee charged</p>
<ul style="list-style-type: none"> <li>- For poor installation due to moving</li> <li>- For reinstallation after initial installation due to customer's requirements</li> <li>- For reinstallation due to customer's unskilled installation</li> <li>- For offering service when a foreign substance is introduced or mis-cleaned by the customer</li> </ul>	<p>Fee charged</p>

**1. The warranty does not cover cleaning, adjusting and instruction for use.**

(Separate standard will apply when repair is impossible)

**2. Fault of customer**

When the product is damaged or broken due to customer's improper use or misuse

- When the power cord is replaced improperly by the user
- When the user drops the product.
- When the user uses unauthorized accessories
- When the product is repaired by unauthorized person

**3. Others**

- When the product is damaged by a natural disaster (fire, flood or earthquake)
- When lifespan of accessories ends

## Definition of WARNING, CAUTIONS and NOTE

- In order to stress the contents of this manual, we define the terms as below. Please follow the warning and cautions instruction.
- The manufacturer or service agents are not responsible for damage resulting from inappropriate use or carelessness.

### WARNING

There may be serious injuries, fatal accidents or financial damages if you violate this instruction

### CAUTIONS





There may be slight injuries or reduced damages if you violate this instruction

### NOTE

There may not be any dangerous events, but it is important to note this instruction for installation, use, maintenance or repair

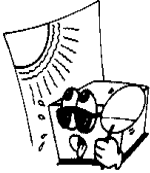
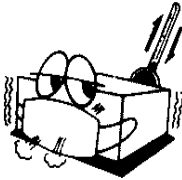
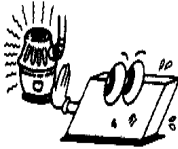
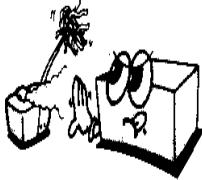
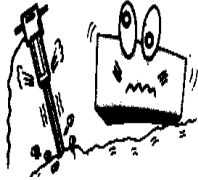
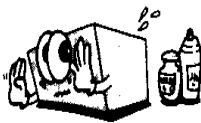
## Environment Instructions

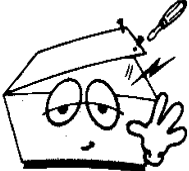
- Please do NOT use or place the product in such environments explained below.

	<p>Steamy environment. Do not use the product with wet hands.</p>		<p>Direct sunlight.</p>
	<p>Place with high fluctuation of temperature. (Scope of temperature is 5°C ~ 40°C, and the scope of humidity is 10% ~ 90%)</p>		<p>Near electronic heaters</p>
	<p>High humidity or ill-ventilated place</p>		<p>Place where excessive shock or vibration may occur</p>
	<p>Place exposed to flammable chemicals or explosive gas.</p>		<p>Please note there is no dust or metal in the product.</p>
	<p>Do not disassemble the product. The product warranty does not cover problems resulting from disassembling the product.</p>		<p>Do not plug the power supply cord before installing the product completely. It may cause damage on the product.</p>

## Safety Instructions for Electricity

Please note the following precautions before using the product.

- Is the power supply cord proper? (100 - 240V AC)
- Is every cord connected properly to the product?
- Is the grounding connected correctly? (Otherwise, noise can occur.)

### Classification.

- This device is classified as follows, in accordance with IEC60601-1.
- Its classification against electric shocks is Class I, Type CF defibrillation - proof applied part.
- Degree of protection against harmful ingress of water: Ordinary
- It is not proper to use this product near a flammable anesthetic or solvent.
- Continuous operation.
- IEC/EN60601-1-2 (Electromagnetic Compatibility Requirements) standard :

Classification	Description
Class A	The device or system is suitable for use in all establishments other than domestic and those directly connected to the public low-voltage power supply network that supplies buildings used for domestic purposes. Mains power should be a typical commercial or hospital environment.

### NOTE

Diagnosis provided by Cardio7 must be confirmed by a qualified medical professional.

### Note

The EMISSIONS characteristics of this equipment make it suitable for use in industrial areas and hospitals (CISPR 11 class A). If it is used in a residential environment (for which CISPR 11 class B is normally required) this equipment might not offer adequate protection to radio-frequency communication services. The user might need to take mitigation measures, such as relocating or re-orienting the equipment.

## Safety Messages

The following messages apply to the product as a whole. Specific messages may also appear elsewhere in the manual.

**WARNING:**

ACCIDENTAL SPILLS — If liquids enter a device, take the device out of service and have it checked by a service technician before it is used again.

To avoid electric shock or device malfunction, liquids must not be allowed to enter the device.

**WARNING:**

BATTERY OPERATION — If the integrity of the electrical ground is in doubt, operate the unit from its battery.

**WARNING:**

CONNECTION TO MAINS — This is class I equipment.

The mains plug must be connected to an appropriate power supply.

**WARNING:**

MAGNETIC AND ELECTRICAL INTERFERENCE — Magnetic and electrical fields are capable of interfering with the proper performance of the device.

For this reason, make sure that all external devices operated in the vicinity of the device comply with the relevant EMC requirements. X-ray equipment or MRI devices are possible sources of interference as they may emit higher levels of electromagnetic radiation.

Use of this equipment adjacent to or stacked with other equipment should be avoided because it could result in improper operation. If such use is necessary, this equipment and the other equipment should be observed to verify that they are operating normally.

**WARNING:**

EXPLOSION HAZARD — DO NOT use in the presence of flammable anesthetics vapors or liquids.

**WARNING:**

INTERPRETATION HAZARD — Computerized interpretation is only significant when used in conjunction with clinical findings.

A qualified physician must verify all computer-generated diagnoses.

**WARNING:**

OPERATOR — Medical technical equipment such as this system must be used only by qualified and trained personnel.

**WARNING:**

SHOCK HAZARD — Improper use of this device presents a shock hazard. Strictly observe the following guidelines. Failure to do so may endanger the lives of the patient, user, and bystanders.

When disconnecting the device from the power line, remove the plug from the wall outlet before disconnecting the cable from the device; otherwise, there is a risk of coming into contact with line voltage by inadvertently introducing metal parts in the sockets of the power cord.

Additional equipment connected to medical electrical equipment must comply with the respective IEC or ISO standards (e.g. IEC 60950 for data processing equipment). Furthermore all configurations shall comply with the requirements for medical electrical systems (see IEC 60601-1-1 or clause 16 of the 3 Ed. of IEC 60601-1, respectively). Anybody connecting additional equipment to medical electrical equipment configures a medical system and is therefore responsible that the system complies with the requirements for medical electrical systems.

# SpiroCare Operation Manual

Attention is drawn to the fact that local laws take priority over the above-mentioned requirements.

If in doubt, consult your local representative or the technical service department.

**WARNING:**

**SITE REQUIREMENTS** — Improper placement of the device and/or accessories may result in a hazard to the patient, operator, or bystanders.

Do not route cables in a way that they may present a stumbling hazard.

For safety reasons, all connectors for patient cables and lead-wires are designed to prevent inadvertent disconnection, should someone pull on them.

For devices installed above the patient, adequate precautions must be taken to prevent them from dropping on the patient.

**CAUTION:**

**ACCESSORIES (SUPPLIES)** — Parts and accessories used must meet the requirements of the applicable IEC 60601 series safety standards and essential performance standards, and/or the system configuration must meet the requirements of the IEC 60601-1-1 medical electrical systems standards.

Use of accessories, transducers and cables other than those specified or provided by the manufacturer of this equipment could result in increased electromagnetic emissions or decreased electromagnetic immunity of this equipment and result in improper operation.

**CAUTION:**

**ACCESSORIES (EQUIPMENT)** — The use of accessory equipment that does not comply with the equivalent safety requirements of this equipment may lead to a reduced level of safety of the resulting system.

Consideration relating to the choice of equipment shall include:

- Use of the accessory in the patient vicinity, and Evidence that the safety certification of the accessory has been performed in accordance with the appropriate IEC 60601-1 and/or IEC 60601-1-1 harmonized national standard.

**CAUTION:**

**BATTERY POWER** — If a device equipped with an optional battery pack will not be used or connected to the power line for a period of over six months, remove the battery.

**CAUTION:**

**BEFORE INSTALLATION** — Compatibility is critical to safe and effective use of this device. Please contact your local sales or service representative prior to installation to verify equipment compatibility.

**CAUTION:**

**DISPOSABLES** — Disposable devices are intended for single use only. They should not be reused as performance may degrade or contamination could occur.

**CAUTION:**

**DISPOSAL** — At the end of its service life, the product described in this manual, as well as its accessories, must be disposed of in compliance with local, state, or federal guidelines regulating the disposal of such products.

If you have questions concerning the disposal of the product, please contact bionet or its representative.

**CAUTION:**

**EQUIPMENT DAMAGE** — Devices intended for emergency application must not be exposed to low temperatures during storage and transport to avoid moisture condensation at the application site.

Wait until all moisture has vaporized before using the device.

Portable RF communications equipment (including peripherals such as antenna cables and external antennas) should be used no closer than 30 cm (12 inches) to any part of the [ME EQUIPMENT or ME SYSTEM], including cables specified by the manufacturer.

# SpiroCare Operation Manual

**CAUTION:**

ELECTRIC SHOCK — To reduce the risk of electric shock, do not remove cover or back. Refer servicing to qualified personnel.











**CAUTION:**

OPERATOR — Medical technical equipment such as this electrocardiograph system must only be used by persons who have received adequate training in the use of such equipment and who are capable of applying it properly.



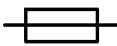



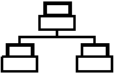

**CAUTION:**

SUPERVISED USE — This equipment is intended for use under the direct supervision of a licensed health care practitioner.

## Safety Symbols

Symbols	Contents
	ATTENTION : Consult accompanying documents
	Consult instructions for use: This symbol advises the reader to consult the operating instructions for information needed for the proper use of the device.
	Safety Sign : To signify that the instruction manual must be read. Reading the instruction manual before starting work or before operating equipment.
	General prohibition sign
	Defibrillation –proof type CF APPLIED PART
	Type B APPLIED PART
	Alternating Current Power
	Fuse
	Conductor provides a connection between equipment and the potential equalization bus bar of the electrical installation
	ECG Patient Cable Connector
	USB Connector

# SpiroCare Operation Manual

Symbols	Contents
	Spirometry Connector
	Local Area Network(LAN) Connector
	Power Off
	Power On
	Battery Operation Indicator
	AC Power Connection Indicator
	Manufacturer name and address
	Authorized European representative
	<p>Waste of electrical and electronic equipment must not be disposed as unsorted municipal waste and must be collected separately.</p> <p>Please contact an authorized representative of the manufacturer for information concerning the decommissioning of your equipment.</p>

# Contents

<b>Chapter 1. General Information.....</b>	<b>16</b>
2) Indication for use .....	16
1) Product Overview .....	17
2) Indication for use .....	17
3) Product Features .....	18
4) Product Configuration .....	19
Basic Components and Accessories .....	19
Body Configuration .....	22
Spirometer Configuration .....	25
Front Panel .....	29
Control Panel .....	31
Power.....	32
5) System Installation .....	<b>33</b>
Precautions For Installation .....	34
Power Connection .....	34
Paper Installation.....	34
System Start.....	35
<b>Chapter 2. Installing Spirometer.....</b>	<b>36</b>
1) Connecting Spirometer Handle.....	37
2) Installing Mouthpiece .....	37
<b>Chapter 3. Using Spirometer.....</b>	<b>39</b>
1) Start .....	40
2) Entry of Patient Information .....	41
3) FVC(Forced Vital Capacity) TEST .....	46
FVC Test .....	46
FVC+(PRE-POST Bronchodilator Comparison) Test.....	58
4) SVC(Slow Vital Capacity) TEST .....	61

5) MVV(Maximum Voluntary Ventilation) TEST .....	66
6) Calibration.....	71
7) System Setup .....	76
Basic Setup.....	77
Network Setup .....	83
Hospital Setup .....	97
SPIRO Setup .....	98
Calibration Setup.....	103
Service Setup .....	104
<b>Chapter 4. Spiro file management .....</b>	<b>109</b>
1) Display and function.....	110
2) Data printing.....	111
3) Data deleting .....	112
4) System Setup .....	113
5) Switching menu.....	115
6) Patient information.....	116
7) Data search.....	117
8) Data transfer.....	118
9) Data import.....	119
<b>Chapter 5. Spiro worklist management.....</b>	<b>122</b>
1) Display and function.....	123
2) Spiro Test.....	124
3) Data deleting .....	125
4) System Setup .....	126
5) Switching menu.....	127
6) Patient information.....	127
7) Data search.....	128

**Chapter 6. System Management..... 129**

- 1) Maintenance and Cleaning ..... 130**
- 2) Regular Check-up ..... 131**
- 3) Trouble Shooting ..... 131**
- 4) Manufacturer Declaration..... 135**

**Chapter 7. Specification ..... 141**

## Chapter 1. General Information

### 1) Product Overview

### 2) Indication for use

### 3) Product Features

### 4) Product Configuration

- Basic Components and Accessories

- Body Configuration

- Spirometer Configuration

- Front Panel

- Control Panel

- Power

### 5) System Installation

- Precautions For Installation

- Power Connection

- Paper Installation

- System Start

## 1) Product Overview



SpiroCare is a Spirometer device capable of measuring and recording lung capacities of patients. Upon entering information on the patient, users can get not just lung capacity of patients measured by SpiroCare, but also record of automatic detection of abnormalities, which SpiroCare calculated using measurements and patient information. In addition, the device allows users to have patient information to be printed alongside spirometer reports, so that users can sort and manage charts confidently. Furthermore, user convenience has been enhanced by digital file management function in which users can retrieve saved data on the device from connected PCs. A battery (optional) can be added to the device so that device can be operated conveniently during bedside visits or emergency conditions.

## 2) Indication for use

The Spirometer is intended for prescription use only to conduct diagnostic spirometry testing of adults and pediatric patients in general practice, speciality physician, and hospital settings.

### Indications

The ECG has proven to be among the most useful diagnostic tests in clinical medicine. The ECG is now routine in the evaluation of patients with implanted defibrillators and pacemakers, as well as to detect myocardial injury, ischemia, and the presence of prior infarction as well. In addition to its usefulness in ischemic coronary disease, the ECG, in conjunction with ambulatory ECG monitoring, is of particular use in the diagnosis of disorders of the cardiac rhythm and the evaluation of syncope.

### Contraindications

No absolute contraindications to performing an electrocardiogram, other than patient refusal, exist. Some patients may have allergies, or more commonly, sensitivities to the adhesive used to affix the leads; in these cases, hypoallergenic alternatives are available from various manufacturers.

## 3) Product Features

- Can perform real time monitoring of Lung Functionality testing progress and results via the device's LCD screen; best result out of 3 trials will be automatically selected as outcome.
- Get diagnostic reports using automatic detection by entering patient information
- Results of the lung function test can be saved on a long term basis by transferring them to the connected PC, and a hard copy can be retained after printing it out with a general PC printer.
- Unlike competitors' mouthpieces (screen or turbine modules) which needs to be washed and disinfected after each use due to potential germ and bacteria growth, SpiroCare' mouthpiece uses patented SmarTube™ technology which is disposable and does not require such efforts by users.
- Effective management of charts is enabled, as patient information and user information are available to be entered and printed out.
- Able to attach a battery so that the device can become portable
- Up to 200 recordings can be saved on device memory, and saved data can be move to other PC by USB memory or specified network.
- Supply various protocols to connect hospital network, tighten the file and the worklist database.

## 4) Product Configuration

The SpiroCare system consists of the items below. Unpack the package and check the items below are included. Also, be sure to check for any damage to the body and accessories.

### Basic Components and Accessories

#### ■ Main Body



- ① SpiroCare body (1 EA)
- ② User Manual (1 EA)
- ③ ECG Paper (1 EA)
- ④ Power Cable (1 EA)

# SpiroCare Operation Manual

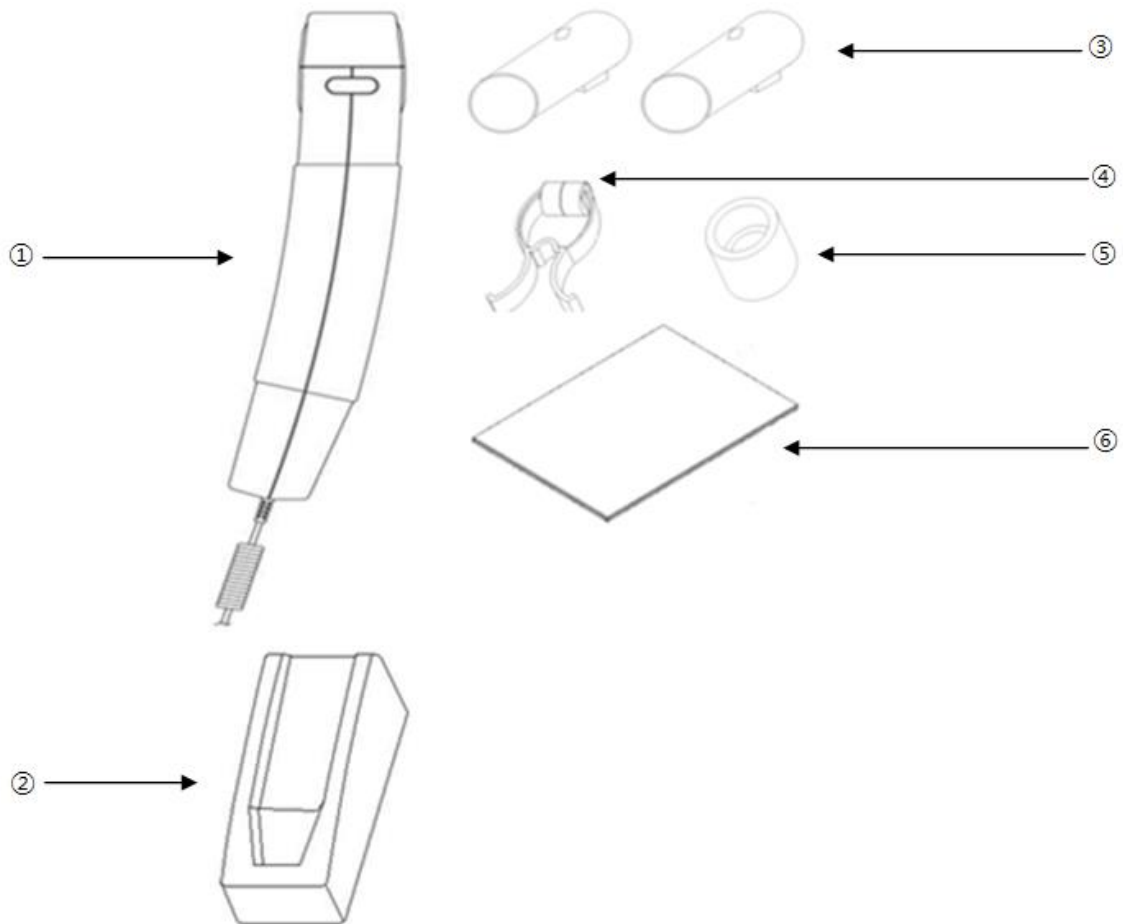

- ① Spirometer Handle (1 EA) - Length: 880mm (Normal), 3,480mm (Max)
- ② Handle Dock (1 EA)
- ③ Disposable Mouthpiece (2 EA)
- ④ Nose clip (1 EA)
- ⑤ Mouthpiece Adapter (1 EA)
- ⑥ Quick use & diagnosis guide

# SpiroCare Operation Manual

## Options



- ① Battery (1 EA)
- ② Cart (1 EA)
- ③ PFT filter (100EA)
- ④ Calibration Syringe[3L] (1 EA)

### Caution

You may have distortion or signal noise when you use nonstandard or other brand's accessories. We strongly recommend you use only the authorized accessories which we supply.

### WARNING

How to replace battery: Please make sure you use the right battery we show here. Otherwise we are not liable for any damages and/or explosion/fire caused by using the wrong battery.



**Lithium-ion battery**  
(11.1V / 2600mAh)



**Ni-MH Battery**  
(12V / 2600mAh)

## Body Configuration

### ■ Top view

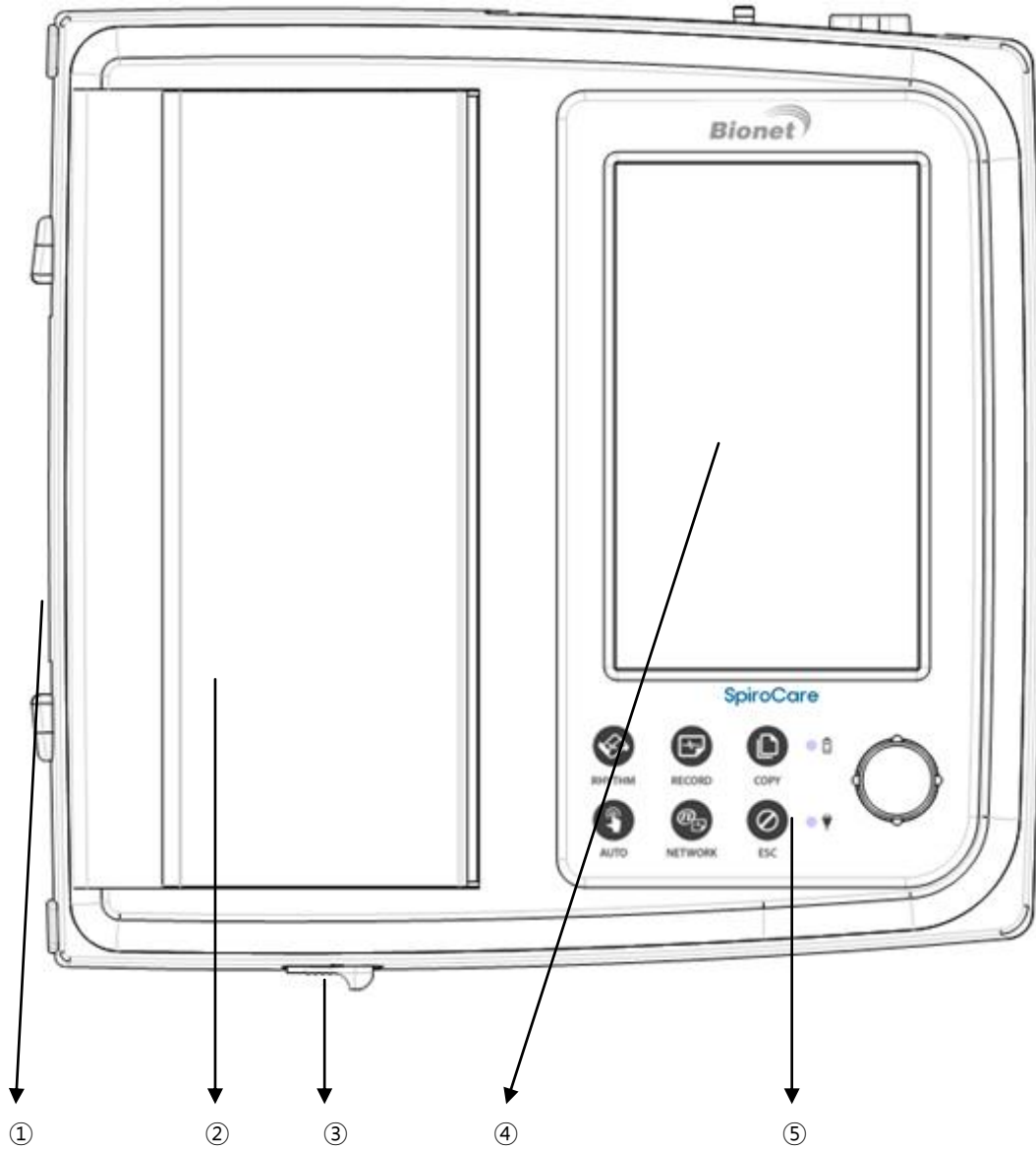

- ① Handle
- ② Printer Cover
- ③ Printer Cover Switch
- ④ LCD
- ⑤ Control Panel

# SpiroCare Operation Manual

## ■ Front View

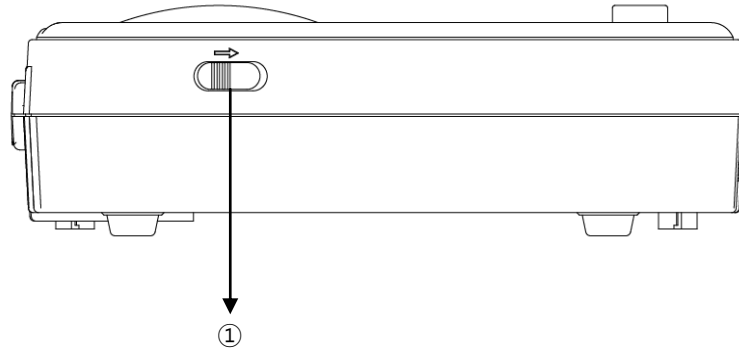

## ① Printer Cover Switch

## ■ Rear View

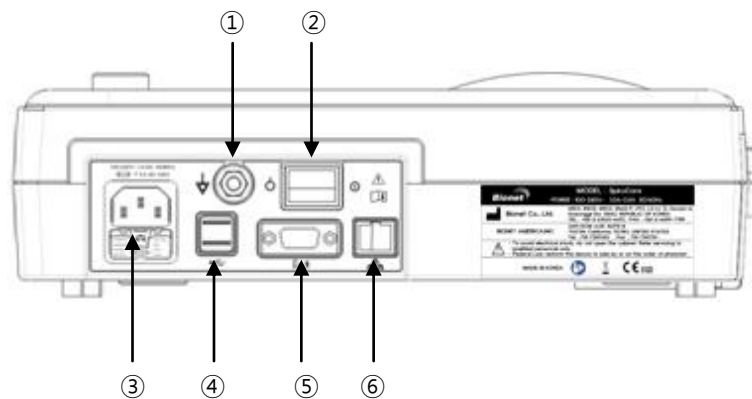

## ① Protective Ground Terminal

## ② Power Switch

## ③ AC Power Connection Port ( Fuse : 250V , 5A ( High breaking type ) )

## ④ USB Port

## ⑤ Spirometry port

## ⑥ RJ45 LAN Port

# SpiroCare Operation Manual

## ■ Left Side View

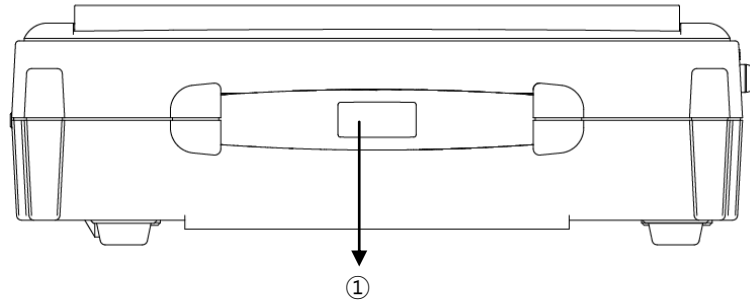

## ① Handle

## ■ Right Side View

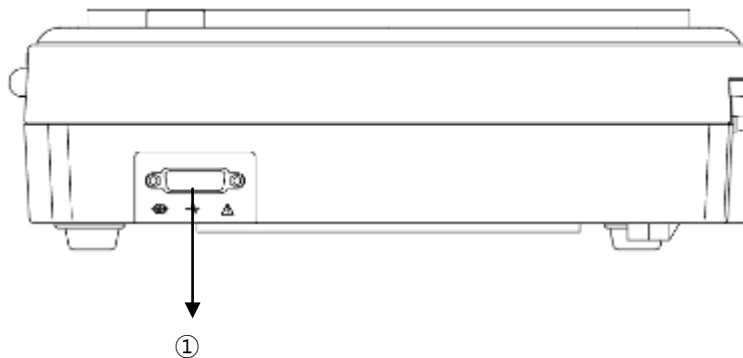

## ① Patient Cable Connection Port

### NOTE

To avoid an expected electric shock, do not open the equipment cover or disassemble the equipment. Refer servicing to Bionet, Inc.

## Spirometer Configuration

### ▣ Front part of spirometer handle

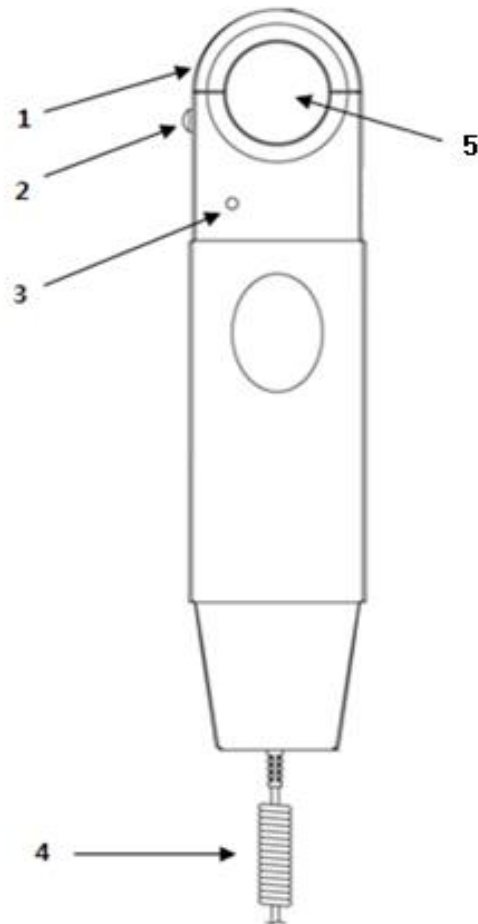

1. Upper cover: Upper cover that fixes mouthpiece.
2. Upper cover lock: Part that locks upper cover fixing the mouthpiece.
3. Action lamp: Lamp showing action status (green)
4. Connection conductor: Conductor connected to serial cable connection hole of serial cable in the back of the main body.
5. Mouthpiece insertion hole: Hole, in which the mouthpiece would be inserted.

## ■ Left side of spirometer handle

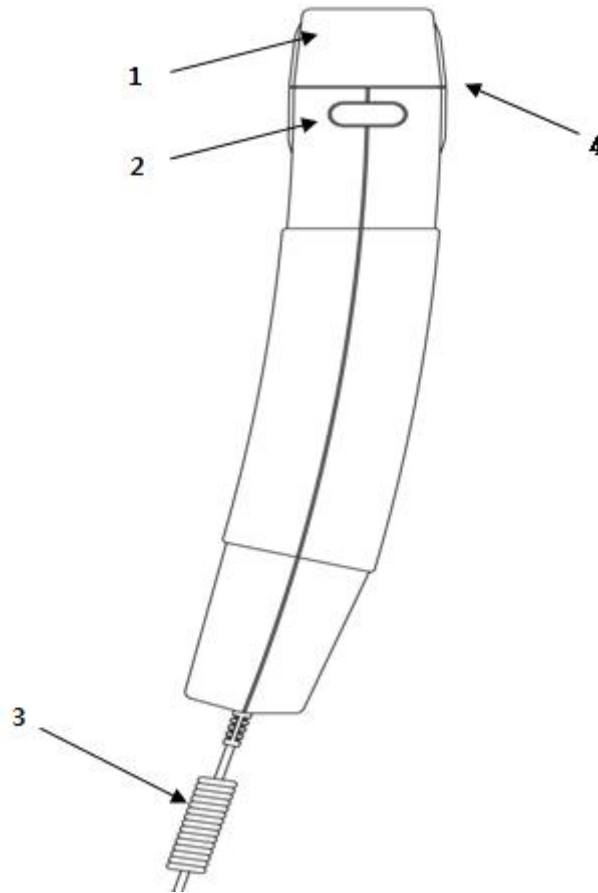

1. Upper cover: Upper cover that fixes mouthpiece.
2. Upper cover lock: Part that locks upper cover fixing the mouthpiece.
3. Connection conductor: Conductor connected to serial cable connection hole in the back of the main body.
4. Mouthpiece insertion hole: Hole, in which the mouthpiece would be inserted.

## ■ Right side of spirometer handle

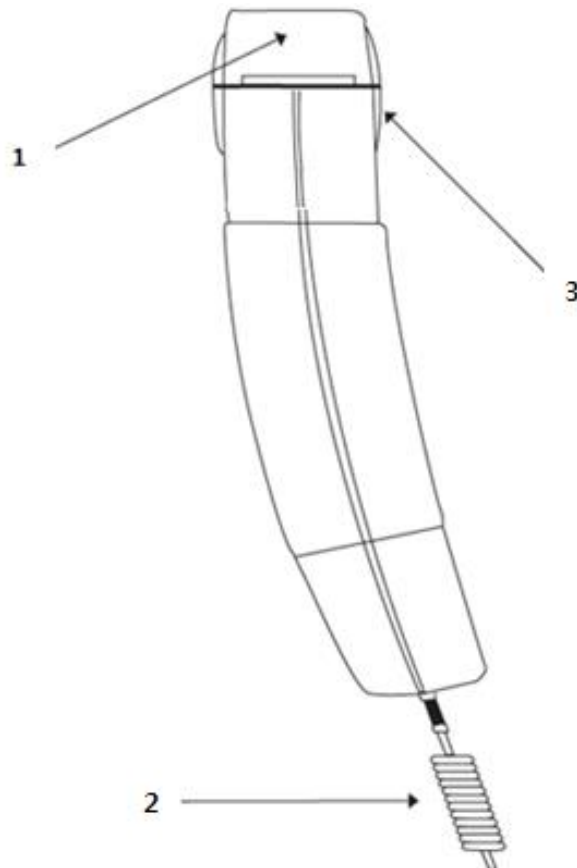

1. Upper cover: Upper cover that fixes the mouthpiece.
2. Connection conductor: Conductor connected to serial cable connection hole in the back of the main body.
3. Mouthpiece insertion hole: Hole, in which the mouthpiece would be inserted.

## ■ Back of the spirometer handle

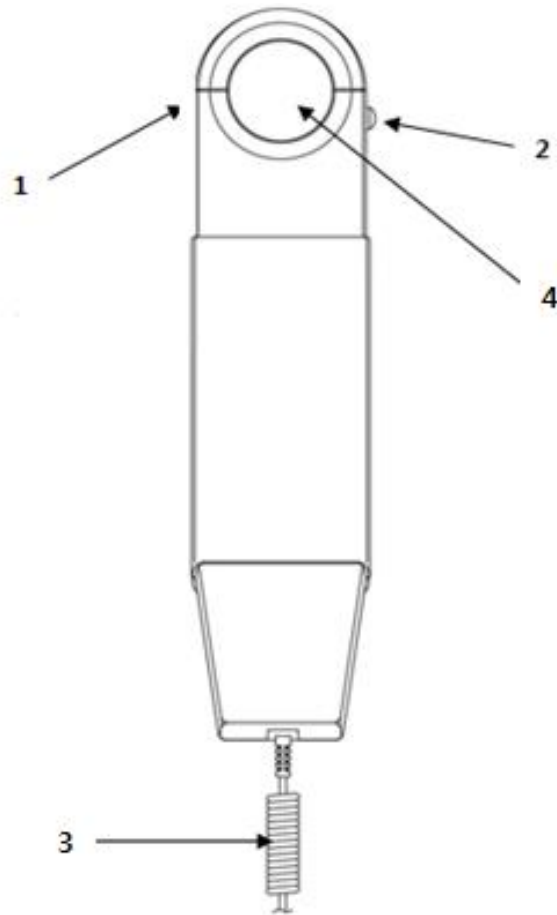

1. Upper cover: Upper cover that fixes the mouthpiece.
2. Upper cover lock: Part that locks upper cover fixing the mouthpiece.
3. Connection conductor: Conductor connected to serial cable connection hole in the back of the main body.
4. Mouthpiece insertion hole: Hole, in which the mouthpiece would be inserted.

## Front Panel

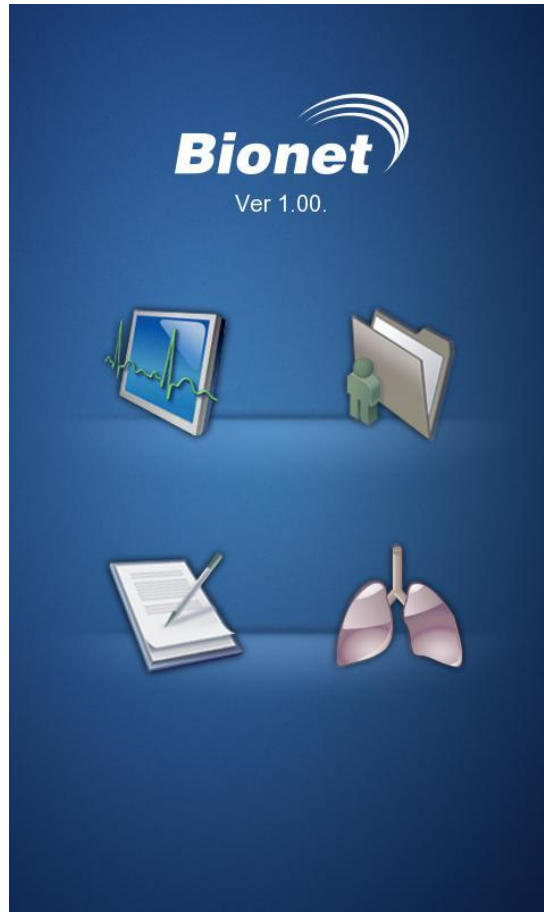

Graphic Display Window

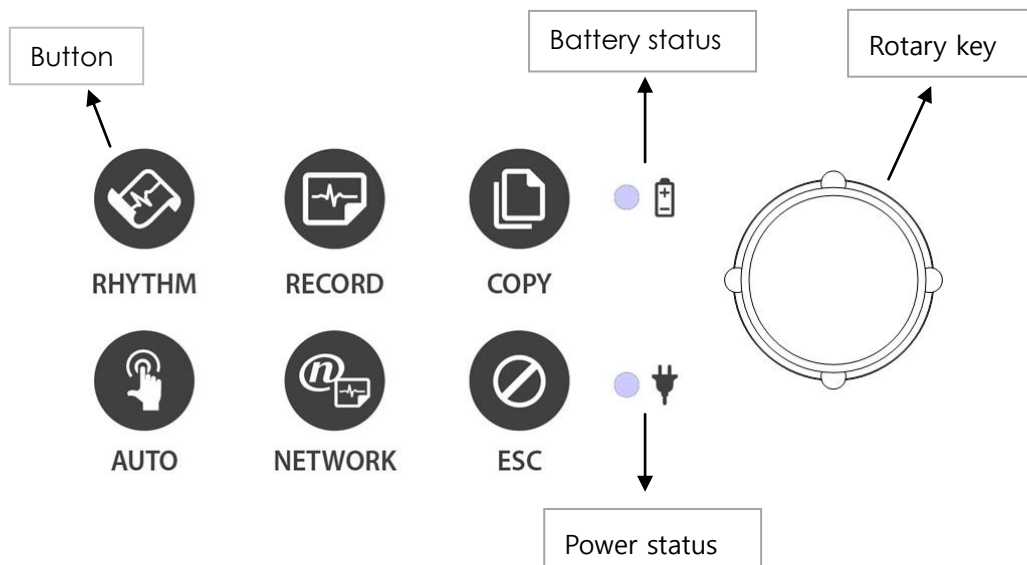

During device boot up, you can see the system version and the company name.

# SpiroCare Operation Manual

The following descriptions explain data on the graphic LCD.

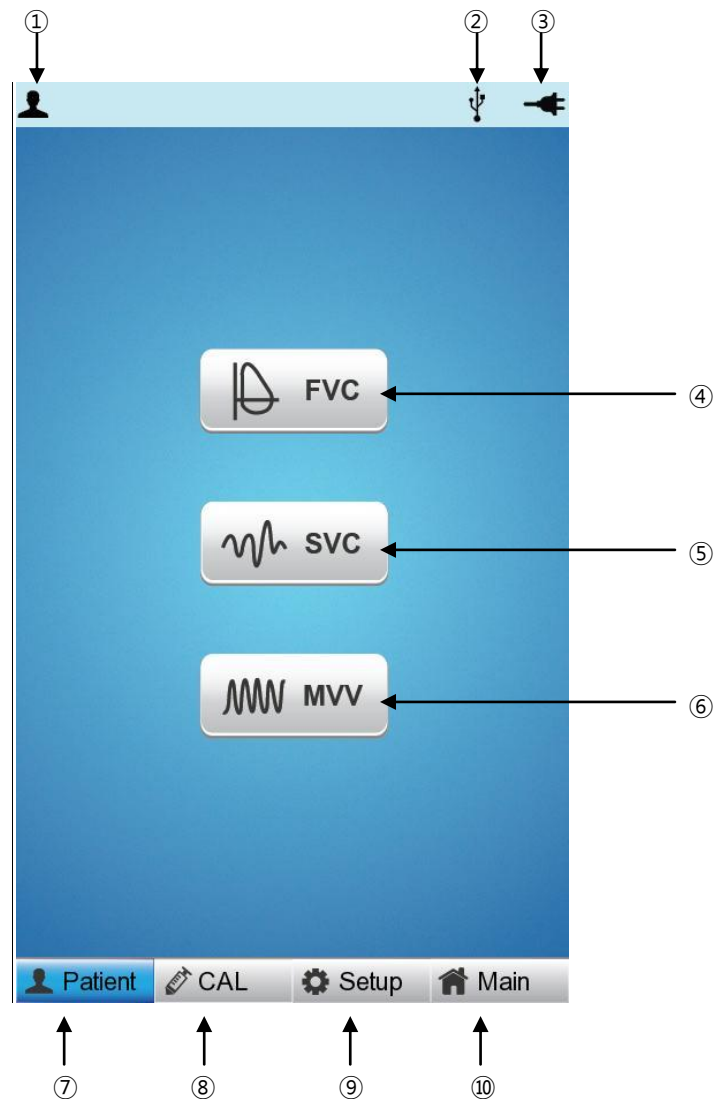

- ① Display patient ID
- ② External connecting device display
- ③ Display battery status or AC power connection status
- ④ Menu to measure Forced volume Vital Capacity (FVC)
- ⑤ Menu to measure Slow Vital Capacity (SVC)
- ⑥ Menu to measure Maximum Voluntary Ventilation (MVV)
- ⑦ Patient information input menu
- ⑧ Menu to calibrate stored parameters such as Pressure and Temperature
- ⑨ Device settings menu
- ⑩ Select a menu to go the Spiro Main, File Management and Worklist Management screen

## Control Panel

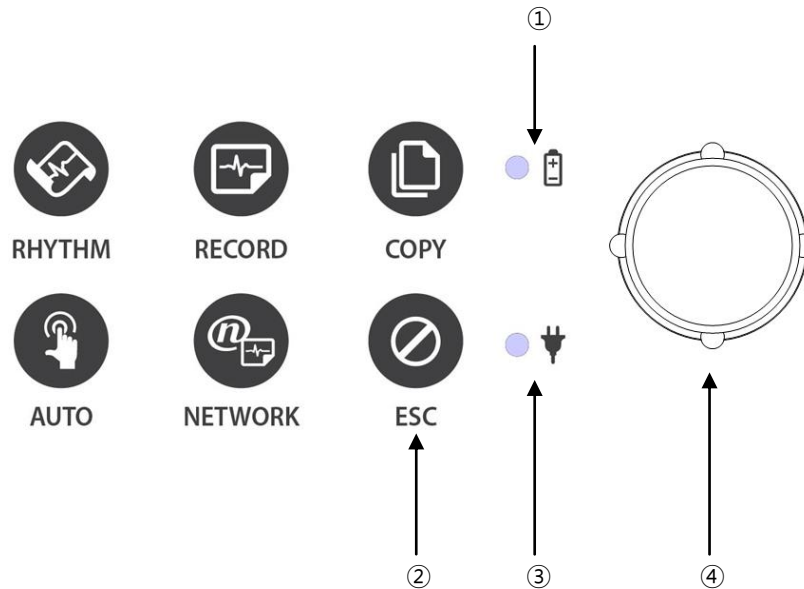

### ■ Button

①		Change the view of the graphic display window to initial main window.
---	--	---

### ■ LED

②		A light indicator lets you know that the battery is on and shows your current battery charging status. A red light indicator lets you know that the battery is charging and a green light indicator lets you know the batter is fully charged.
③		Green light indicates connection with an AC adapter.

### ■ Rotary Switch

④		Use when navigating or selecting menu items (Same functionalities can be achieved by touching menu items on the screen).
---	--	--

## Power

### ■ AC Power

When AC Power is connected to the device, power LED light will be green; if the battery is installed, charging will commence.

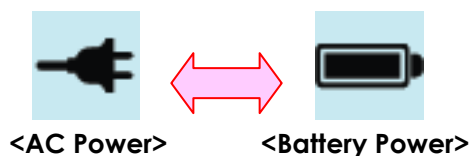

### WARNING





This equipment must be connected to a power supply with a ground.

### ■ Battery Power

The device will get its power from the battery and the unit will display the battery power icon (shown above), when the system is powered on, the battery is connected to the device and the AC power is disconnected. When the battery power is low, an alarm sound will ring from the device speaker and LCD display will show a "Battery Low" message. Connect the AC power immediately or the device will automatically shut down in 1 minute.

- Time to full recharge from full discharge: Max. 3 hours
- Duration of continuous usage after full recharge: if running ECG record in 12 channel format by choosing to set successive function for about 360 min. at 25mm/s and 10mm/mV or in the absence of ECG record, it is possible to record a max. of 200 ECGs.

### ■ Display Battery Power Status

-  : Battery Fully Charged
-  : Battery Charge Half-Full
-  : Battery Charge Low
-  : Battery Almost Fully Drained

### ■ Replacing Battery

When replacing battery for this device, the same type of battery should be used.

- Type: Lithium-ion battery 3ICR19/65 ( 11.1V-2600mAh )
- When to replace: Battery will automatically be charged when the device is connected to AC power, and cannot be charged when separated from the device. Battery is designed to have a charging cycle of 300 times or more. If the device only lasts 20 minutes or less on battery power, the battery needs to be replaced. Additionally, when a battery pack is damaged or leaking chemicals, replace it immediately. Do not use damaged battery packs with the device.

## WARNING

EXPLOSION HAZARD —

DO NOT incinerate the battery or store at high temperatures. Serious injury or death could result.

### **The Impact of Lithium-Ion Battery Technology on the Battery**

The following are the key points you should know about Lithium-Ion battery technology:

The battery will discharge on its own, even when it is not installed in a monitor. This discharge is the result of the Lithium-Ion cells and the bias current required for the integrated electronics.

By the nature of Lithium-Ion cells, the battery will self-discharge.

The self-discharge rate doubles for every 10°C (18°F) rise in temperature.

The capacity loss of the battery degrades significantly at higher temperatures.

As the battery ages, the full-charge capacity of the battery will degrade and be permanently lost. As a result, the amount of charge that is stored and available for use is reduced.

### **Conditioning Guideline**

The battery in the monitor should be fully charged and discharged every six months and condition it using the battery charger.

### **Storage Guideline**

Store the battery outside of the monitor at a temperature between 20°C to 25°C (68°F to 77°F).

When the battery is stored inside a monitor that is powered by an AC power source, the battery cell temperature increases by 15°C to 20°C (59°F to 68°F) above the room's ambient temperature. This reduces the life of the battery.

When the battery is stored inside a monitor that is continuously powered by an AC power source and is not powered by battery on a regular basis, the life of the battery may be less than 12 months. BIONET recommends that you remove the battery and store it near the monitor until it is needed for transport.

### **How to Recycle the Battery**

When the battery no longer holds a charge, it should be replaced. The battery is recyclable. Remove the old battery from the monitor and follow your local recycling guidelines.

## WARNING

EXPLOSION HAZARD —

DO NOT incinerate the battery or store at high temperatures. Serious injury or death could result.

## 5) System Installation

### Precautions For Installation

While installing SpiroCare, please pay attention to following items:

- Use the equipment between the ambient temperature 5 to 40°C (25 to 104°F) and humidity 10 -90%.
- Check the power cord is properly connected, and the probe carefully handled.
- Do not plug multiple cords in a power outlet.
- Install and operate SpiroCare unit on a flat surface.
- If you experience noise, ground the device.
- Do not use a power cord that may make a connection noise.
- Device settings will be recorded in the internal memory even when it is off.
- Prevent any shock or excessive force that may cause damage to the device.
- Place the device away from any dust or flammable materials.

### Power Connection

The equipment needs electrical power to operate. Plug in one end of the power cable to wall socket and the other to SpiroCare.

### Paper Installation

- Push the printer cover release switch to the right to open the printer door of the SpiroCare. Install recording paper with the side to be recorded appear on top. Close the cover to finish paper installation process.

Caution
Do not use SpiroCare in combination with any Electro-surgical equipment.

Caution
Users must use either the same type of mouthpiece or any other mouthpieces with biocompatibility certification proven by international standards.

## System Start

When every preference is set, the system version and the company name will be displayed when switched on, and then the initial menu selection will show on the screen as in the figure below.

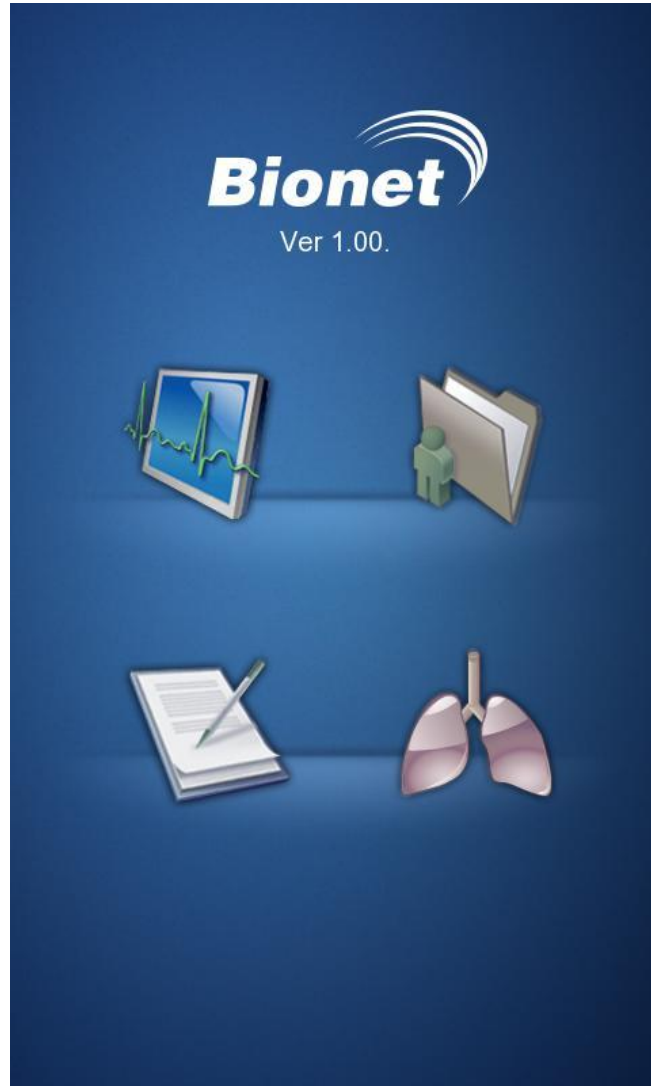

You can move to the main page of the chosen menu by touching the menu on the screen or rotating the key on the control panel.

## **Chapter 2. Installing Spirometer**

**1) Connecting Spirometer Handle**

**2) Installing Mouthpiece**

## 1) Connecting Spirometer Handle

Spirometer handle should be connected to the main body by plugging in the end of its cable to serial input port or USB port in the main body (shown below)

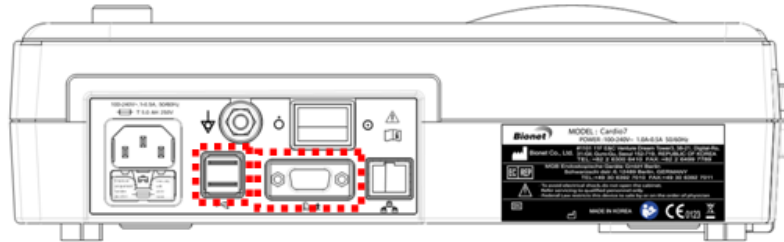

<Rear View>

- (1) Connect spirometer handle to main body while the power of the main body is off.
- (2) Turn on power switch of main body.

### Verifying Spirometer Handle's status

Spirometer handle is ready to operational status when the green lamp on the handle is on.

## 2) Installing Mouthpiece

To start spirometer measurements, mouthpiece should be inserted in spirometer handle. Start by first pressing 'Upper cover lock' in the upper left side of spirometer handle. Then open semicircle upper cover to insert the mouthpiece into a groove made in open side. Finally, close the upper cover to finish mouthpiece installation, by giving it a little pressure on top. For correct placement of mouthpiece, make sure mouthpiece tube is longer in the front side of the spirometer handle than that in the back side



(1)

- (1) First press 'Upper cover lock' in the upper left side of spirometer handle to open semicircle upper cover.

# SpiroCare Operation Manual



(2) Insert Mouthpiece into a groove made in open side

(2)



(3) Close upper cover by giving it a little pressure on top

(3)

## Caution

- Mouthpiece is designed for single-use
- Do not close cover while Lock Switch is pressed.

## Chapter 3. Using Spirometer

### 1) Start

### 2) Entry of Patient Information

### 3) FVC(Forced Vital Capacity) TEST

FVC Test

FVC+(PRE-POST Bronchodilator Comparison) Test

### 4) SVC(Slow Vital Capacity) TEST

### 5) MVV(Maximum Voluntary Ventilation) TEST

### 6) Calibration

### 7) System Setup

Basic Setup

Network Setup

Hospital Setup

SPIRO Setup

Calibration Setup

Service Setup

## 1) Start

Turn on the switch on the main body and locate the selection box in the Spirometer area by turning the rotary key on the initial screen. Afterward, press the rotary key or touch the selection box in the Spirometer area to shift to Spirometer measurement mode.

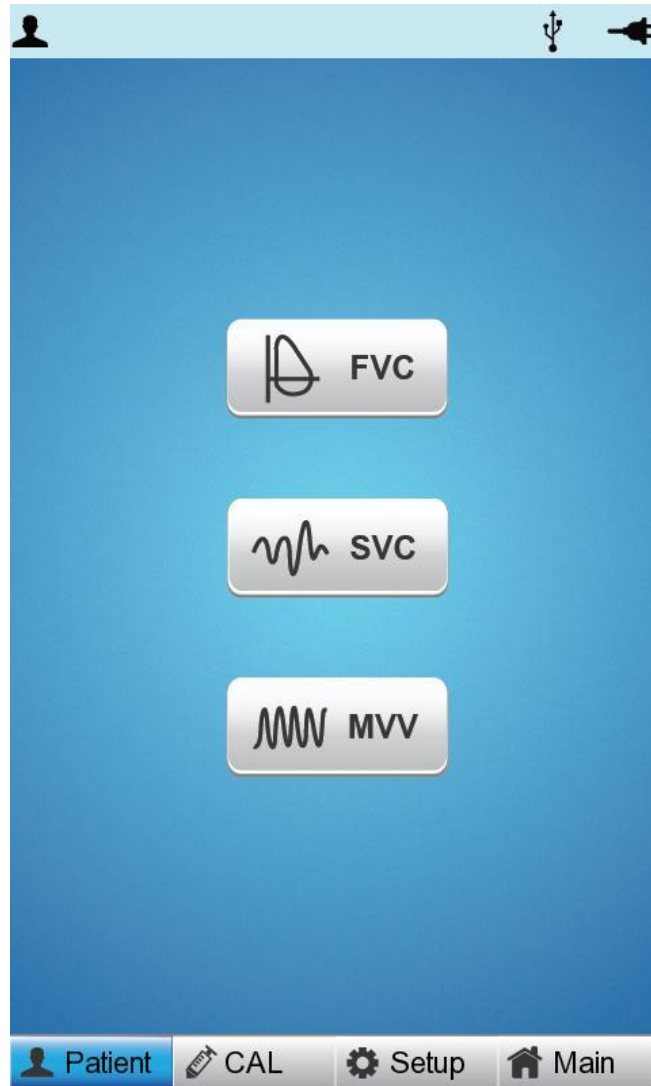

<Menu screen of Spirometer>

To activate the function of the selected item, turn the rotary key on the menu screen of the spirometer above and locate the selection box in the desired item area; afterward, press the rotary key or touch the desired item area.

All functions are selected and activated when the items on the screen are touched or the button/rotary key on the operation panel is used.

## 2) Entry of Patient Information

The personal information of the patient must be entered before the pulmonary function test begins. Specifically, items such as "Age", "Gender", "Height" and "Race", which are indicated as "\*" in their input fields, must be entered because they are essential for the diagnosis of the pulmonary function.

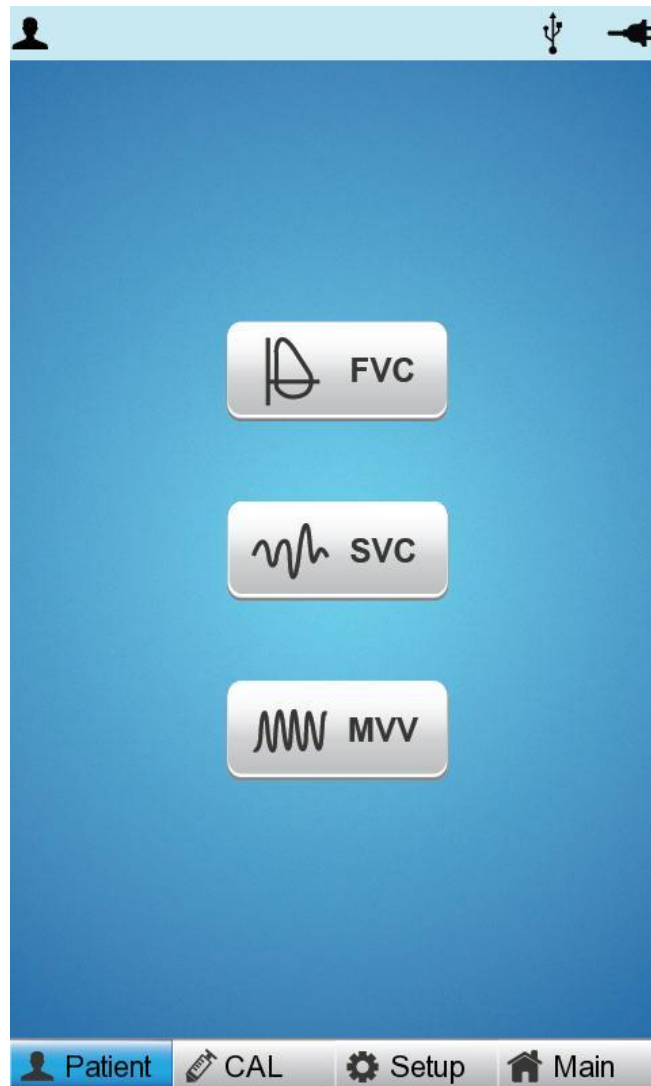

To enter the Patient ID and other information, locate the shaded block in "Patient" as the Patient ID area, and then press the rotary key or touch the area to shift to Patient Information Selection mode as illustrated in the figure below.

The screenshot shows a 'Patient Information' form with the following fields and values:

- ID: [Empty text box]
- Name: [Empty text box]
- Age: [Empty text box] years
- Gender: Female
- Height: [Empty text box] cm
- Weight: [Empty text box] kg
- Race: Asian
- Smoke: No
- Department: [Empty text box]
- Room No: [Empty text box]

Buttons at the bottom: OK, Cancel, New

## <Patient Information Selection Mode>

To activate the Information Input mode, locate the shaded block in the desired "Patient Information" area and press the rotary key. The information can be entered by using the rotary key or touching the desired area. The Entry Mode consists of the Keyboard mode, which enables the input of both characters and numbers, and the Key Pad mode, which enables the input of numbers only. The Key Pad Entry mode appears if no alphanumeric characters need to be fed into the Information Entry section.

### Entering ID

Enter ID value used in the hospital to classify examination result. You can enter a value made from a combination of up to 20 letters and numbers by using the rotary key or the touchscreen. If you select "ID", letter entry space that consists of alphabet and numbers appears on the screen.

If you turn the rotary key to the right, cursor moves consecutively from left top to right bottom. Letters or numbers on which the cursor is placed are highlighted on the screen. If you press the rotary key or touch here, the selected letters or numbers are entered. If you place "OK" on the cursor and press the rotary key after completing entry, the ID numbers entered in advance are saved and the letter entry space disappears from the screen. If you turn the rotary key to the right, the cursor moves to "Name" entry space.

#### NOTE

- When entering an ID, it is impossible to enter special characters such as " , < , > , ? , / , \* , | , ; , \ , etc. (these invalid characters are set to be inactive)
- When entering an ID, an English keyboard will be displayed, regardless of whether there is a multi-language set-up.
- When entering an ID by connecting to an external keyboard, proceed by using general alphabet and numbers only. If you enter an ID using Latin extended characters and Russian, an error may occur when transferring files via PC and USB.

# SpiroCare Operation Manual

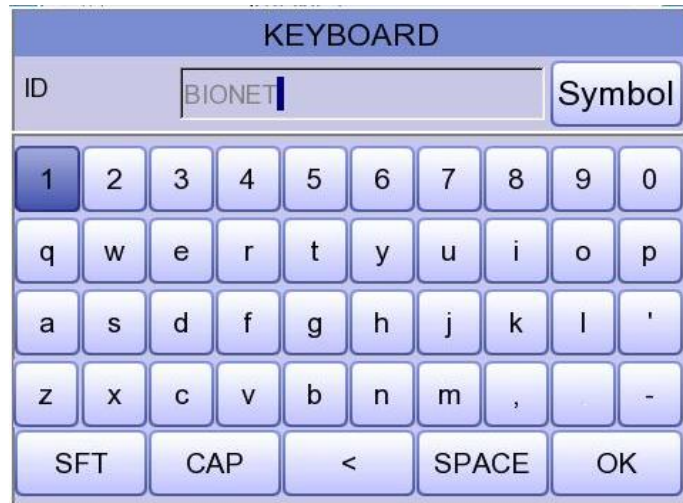

<Keyboard>

## Entering Name

Enter the name of the patient in the same way as in "ID" entry

## Entering Age

After selecting "Age", the number entry keypad titled "Edit Age", as seen below, will appear. Press "OK" key, after entering patient's age.

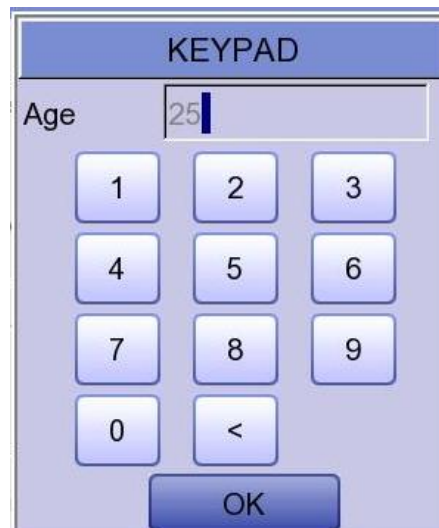

<Keypad>

## Entering Gender

If you press  and turn the rotary key, while "Gender" is highlighted, the patient's gender will alternate between "Male" and "Female". Once selection is complete, you may turn the rotary key clockwise to move the cursor to "Height" entry space.

## Entering Height

Enter "Height" in the same way as Age entry. After completion of the entry, if you place cursor on the "OK" and press the rotary key or use touchscreen, entered information will be saved. If you turn the rotary key to the right, the cursor moves to "Weight" entry space.

## Entering Weight

The Number Entry window appears if "Weight" is selected. Enter the Patient's weight and select "OK." Pressing the "OK" button after entry is complete saves the entered information. If the rotary key is turned to the right, the cursor moves to the "Race" Entry field.

## Entering Race

Enter patient's racial information. The race is registered as Asian, Black and Caucasian. If you press the rotary key in the same way as you did when you entered patient's gender, above-mentioned races appear one after another. If you turn the rotary key to the right, the cursor moves to "Smoke" entry status.

## Entering Smoke

Enter whether the patient smokes or not.

Note
Patient information will be initialized if the language preference is changed at system set-up.

# SpiroCare Operation Manual

## Entering patients information using a barcode reader

Patients' ID can be registered using a barcode scanner. Patients' ID will be entered automatically when the user scans the barcode on Spiro main screen.

Normally barcode scanners are compatible with all products. However, because of inconsistencies in barcode scanner manufacturers implementation of input methods, you need to verify the scanner whether it is supported by Bionet.

- Input methods supported by Bionet : International standards, USB
- Products below are tested and confirmed by Bionet for SpiroCare.

No	Manufacturer	Product name	Product image
1	Symbol	LS-2208	
2	ZEBEX	Z-3110	
3	Honeywell	MS5145	

### Caution

It is must be read the user manual of the barcode scanner to get complete information about it.

The initialization codes for various products would be included. You must run the initialization after verifying the input type.

## 3) FVC(Forced Vital Capacity) TEST

### FVC Test

Select "FVC" by turning the rotary key or touch. At this time, the patient information must be entered beforehand to ensure diagnosis based on the measured results.

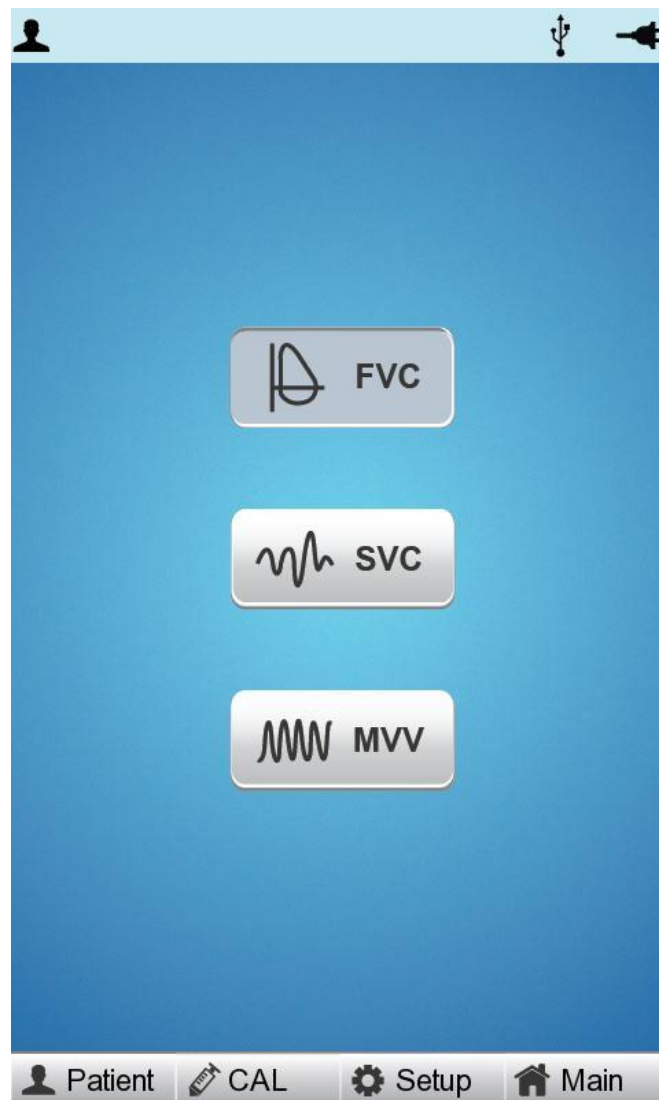

# SpiroCare Operation Manual

When you select the "FVC" menu, the screen shifts to the FVC Test screen following the test preparation process as shown in the figure below.

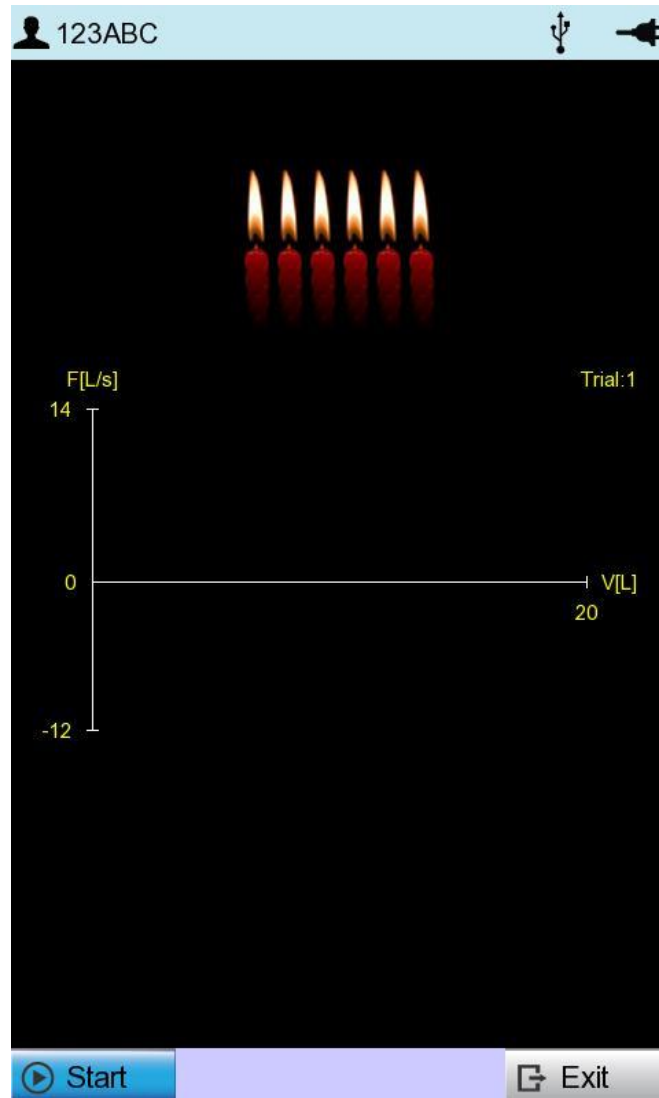

# SpiroCare Operation Manual

A message appears as shown below if the Spirometer handle is not connected or power is turned off on the handle. This message is also displayed in the same way during the SVC Test and MVV Test. At this time, touch "Exit" by hand or press it using the rotary key to go to the main menu and check the handle before resuming the test.



# SpiroCare Operation Manual

The screen below appears, and FVC test measurement is ready if the Spirometer handle is connected normally.

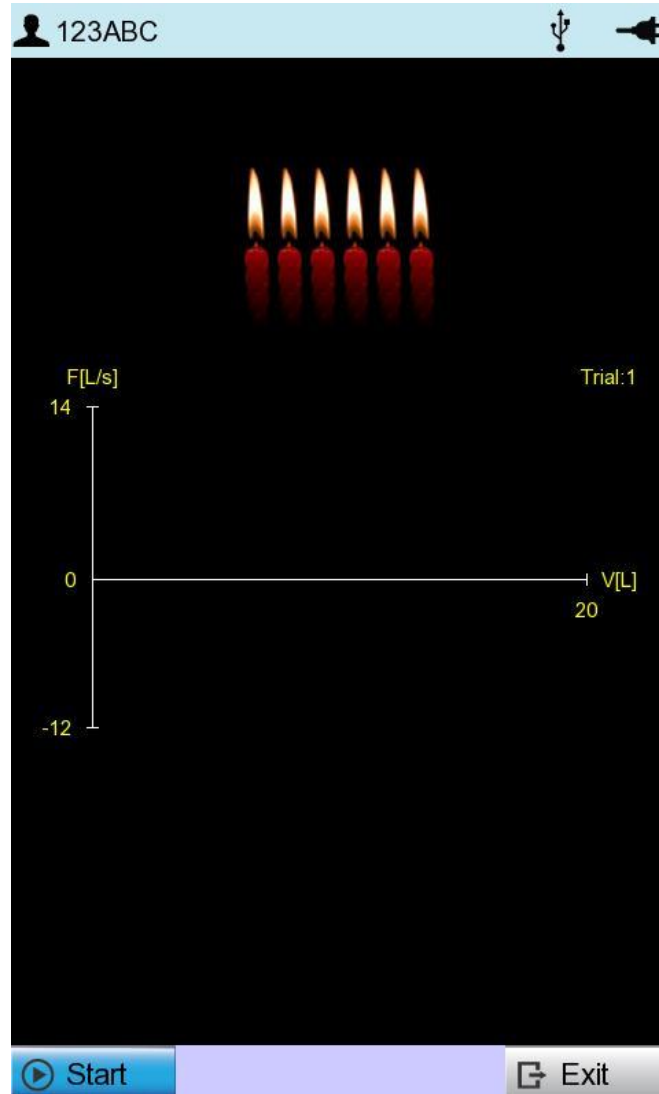

Put the mouthpiece installed the handle on patient lips, and press the "Start" button. After the start alarm, hold the mouthpiece with lips and breathe out to begin.

To ensure accuracy, measurement must be carried out exactly according to the procedure described below.

## < How to breathe in times of FVC measurement >



### 1) Take normal breaths three times or more.

Prepare for the measurement by first taking normal breaths, which are recommended for achieving higher accuracy.



### 2) Inhale as much as possible (TLC level)

Make sure the patient inhales as much air as possible regardless of speed. Instruct the patient to inhale as much as possible.

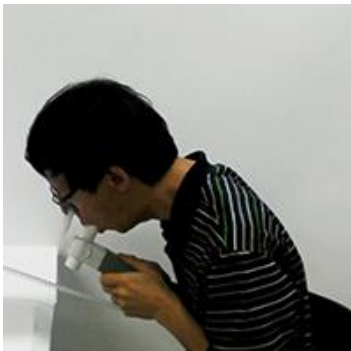

### 3) Exhale as fast and much as possible (Forced expiration)

Make sure the patient exhales as fast as possible until he or she reaches the point where no more exhalation is possible.



### 4) Inhale as fast and much as possible to the end (Forced inspiration)

It is natural for patients to inhale fast, as they run out of breath. You should have patients to inhale as much air as possible to avoid hyperventilation.

5) After that, you should signal the machine that the patient has finished taking the measurement by pressing the stop button on the screen.

# SpiroCare Operation Manual

## NOTE

- In principle, it is done in a standing posture. It is available to do in a sitting position, but it can get a larger effortable lung capacity test when you stand up. It is required that a pregnant, overweight person, or a child do it standing.
- Make sure that the jaw is facing up 15 degrees and stay in this position until the end then do not bend the neck or chin. Do not bend or twist the waist and maintain the initial position until the end.

If the patient has any difficulties with breathing while performing aforementioned tasks, change the procedures as following.

- 1) Take normal breath at least once and then,
- 2) Inhale as much as possible,
- 3) Exhale as much as possible,
- 4) Inhale again.
- 5) Press the "Stop" button.

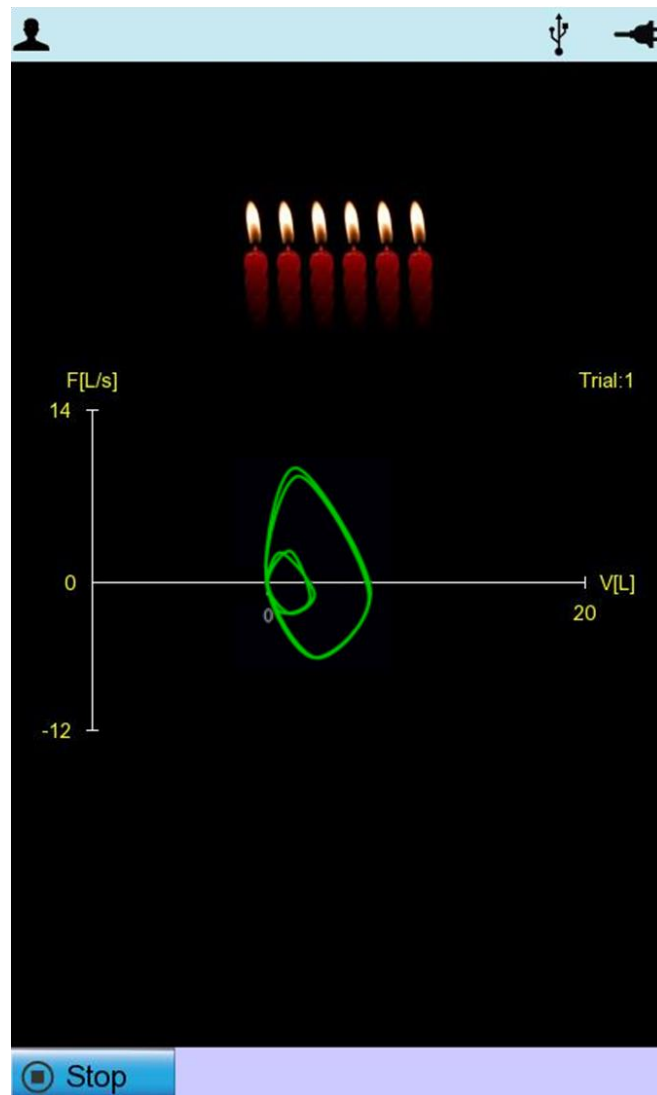

# SpiroCare Operation Manual

If you take breaths in above-mentioned orders, a graph showing the result of normal breaths appears in small size. If you go ahead with step 2 to 4, a big graph is drawn in the screen. If the user presses the button, one round of measurement is finished. The shape of this graph is not important, since the graph drawn during the measurement just indicates the fact that the patient is breathing, and does not correspond with actual breathing data.

## Result screen

Press "Stop" button by using rotary key or touchscreen to signal the machine that measurement is finished. After pressing the button, the following screen showing the result of the measurement will appear.



# SpiroCare Operation Manual

## < Result screen menu >

- **New:** The machine begins to take a new measurement.
- This is used for starting another new test upon completion of measurement. If you click 'Yes,' the screen for a new measurement will appear as shown below; click 'Start' again to start.



# SpiroCare Operation Manual

● **Print:** It prints the measurement result.

- It prints the measurement result in a graph and a chart.

## Note

You should avoid connecting or disconnecting a USB device while printing out, as it could cause the printer module to rattle.

● **VT:** The measured result will be presented as a VT graph.

- The measured result will be presented as a Volume & Time graph as shown below. Press 'FV' again by using the rotary switch or touch to see it in Flow & Volume graph.



## ● Select BEST measurement

- At the end of the measurement, it shows the BEST measurement number selected in the automatic diagnosis. The selection criteria for Best measurement are obtained at the maximum value of the FVC+FEV1. If it needs to change the automatically selected Best measurement, it can select a different measurement number with a touch.

● **Exit:** It finishes measurement mode and returns to the main screen.

- If you press "Yes" after finishing all measurements, the machine will show the main screen.

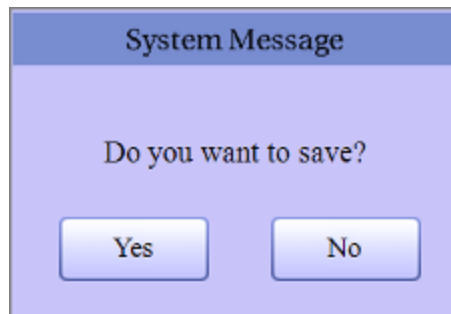

At this time, select "Yes" to save the data, or "No" to cancel.

◆ If "Yes" is selected

(1) A message appears, requiring the entry of Patient ID; if the Patient ID was not entered before saving the data, the Patient Information Entry window would be displayed.

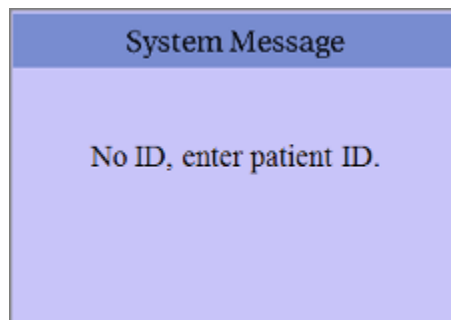

(2) The data-saving process starts if Patient ID is entered

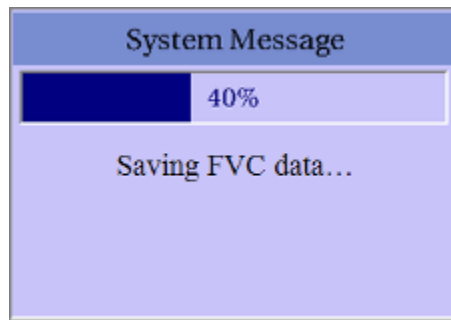

- (3) Once the saving process is complete, a message box asking whether the patient information is to be deleted appears.

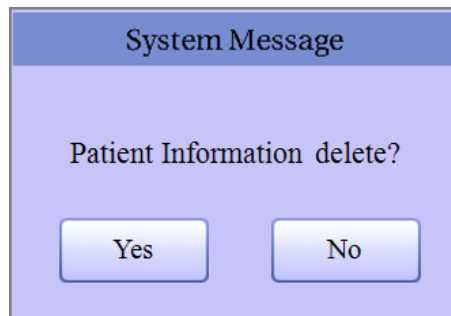

- (4) The main screen of Spiro is displayed.

**NOTE**

The following messages will appear when the memory is full.

- Message appeared after saving the last data

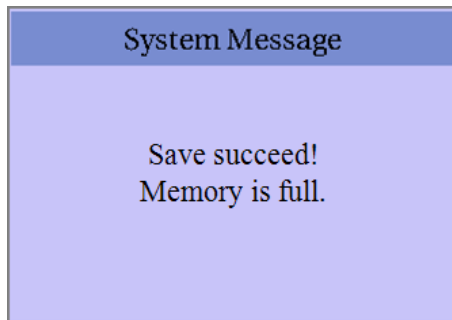

A system message dialog box with a blue header titled "System Message". The text "Save succeed! Memory is full." is displayed in the center.

- Message appears when selecting to save data again after memory full.

# SpiroCare Operation Manual

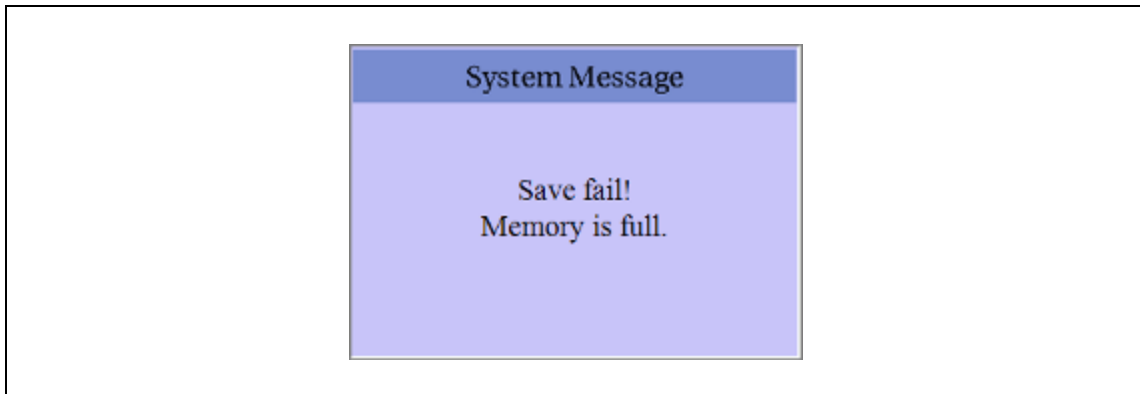

## - FVC Test Print Form

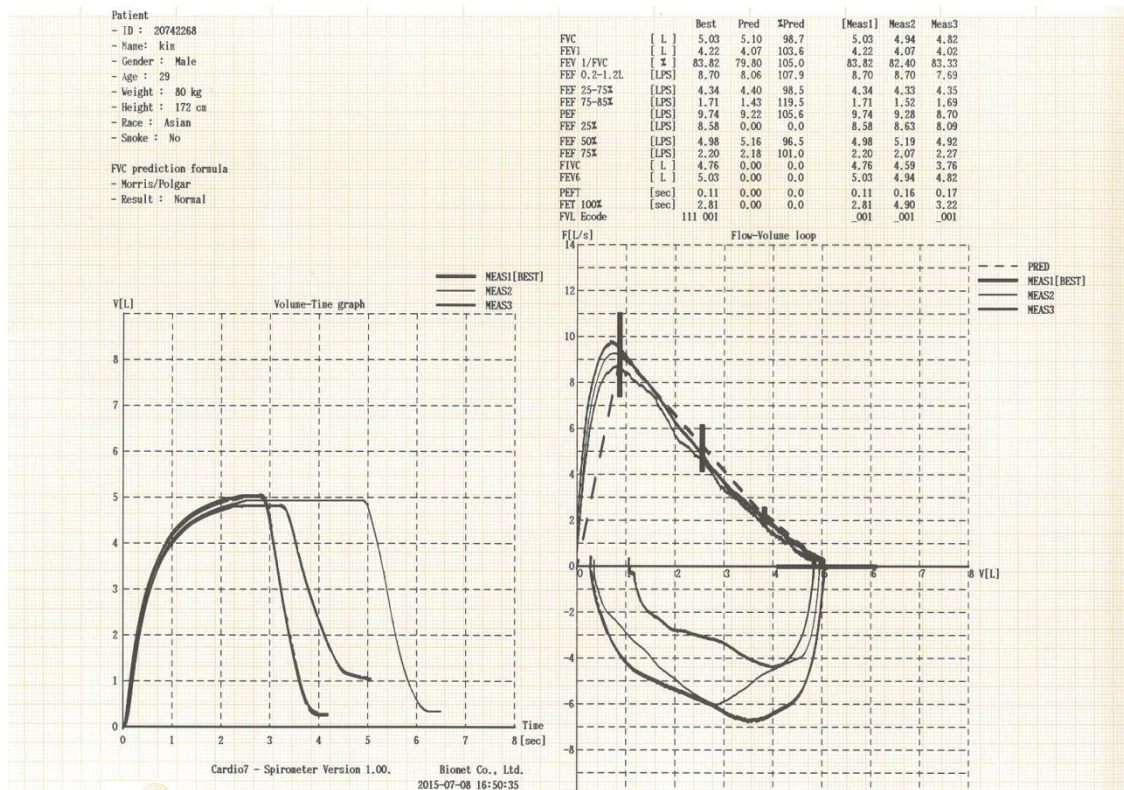

### Note

If a USB device is installed or detached during printout, the printer module may rattle, so please refrain from removing and installing it during printout.

## FVC+(PRE-POST Bronchodilator Comparison) Test

- (1) "FVC+" enables the comparison of the results of the test performed twice before and after medicine is administered. The procedure is as follows: First, conduct the measurement according to the FVC test method, and then save the data.
- (2) Once the data is saved, go to the Data List menu to check the data indicated as "FVC" based on the entered ID type of the patient.

No	ID	Name	Age	Date	Study
1	ddfd1		0	19700101	ECG
2	abcdefg		0	19700101	FVC
3	12345678...		0	19700101	SVC
4	dog		0	19700101	MVV
5	abcdefg		0	20000101	FVC+
6	abcdefg		0	20150101	MVV
7	111	aaa	0	20140101	MVV
8	hhgtggug		46	19700101	ECG
9	ttftyh		0	19700101	ECG
10	help me	RYU	0	19700101	ECG
11	qwe	45678	18	20150101	FVC
12	qwe	45678	18	20150101	SVC
13	7hh		0	20150101	MVV
14	yhh		0	20150101	ECG
15	hgx		0	19700101	FVC
16			0		SVC
17	hhgtggug		46		ECG
18			0		SVC
19	111	aaa	0	20140101	MVV
20	7hh		0	20150101	MVV
21	abcdefg		0	19700101	FVC
22	abcdefg		0	20000101	MVV
23	abcdefg		0	20150101	MVV
24	help me	RYU	0		ECG

Save the results of the first test prior to the administration of

Save the results of the second test after the administration of medicine.

- (3) Select the saved FVC data of the patient from the Post-Medication Test List, and then select Spiro from the Main manu.
- (4) Selecting Spiro from the Main menu leads back to the Spirometer Main menu; at that time, switch from FVC Test menu to 'FVC(P)' can be confirmed. Switch to 'FVC(P)' must be confirmed before conducting test.

# SpiroCare Operation Manual

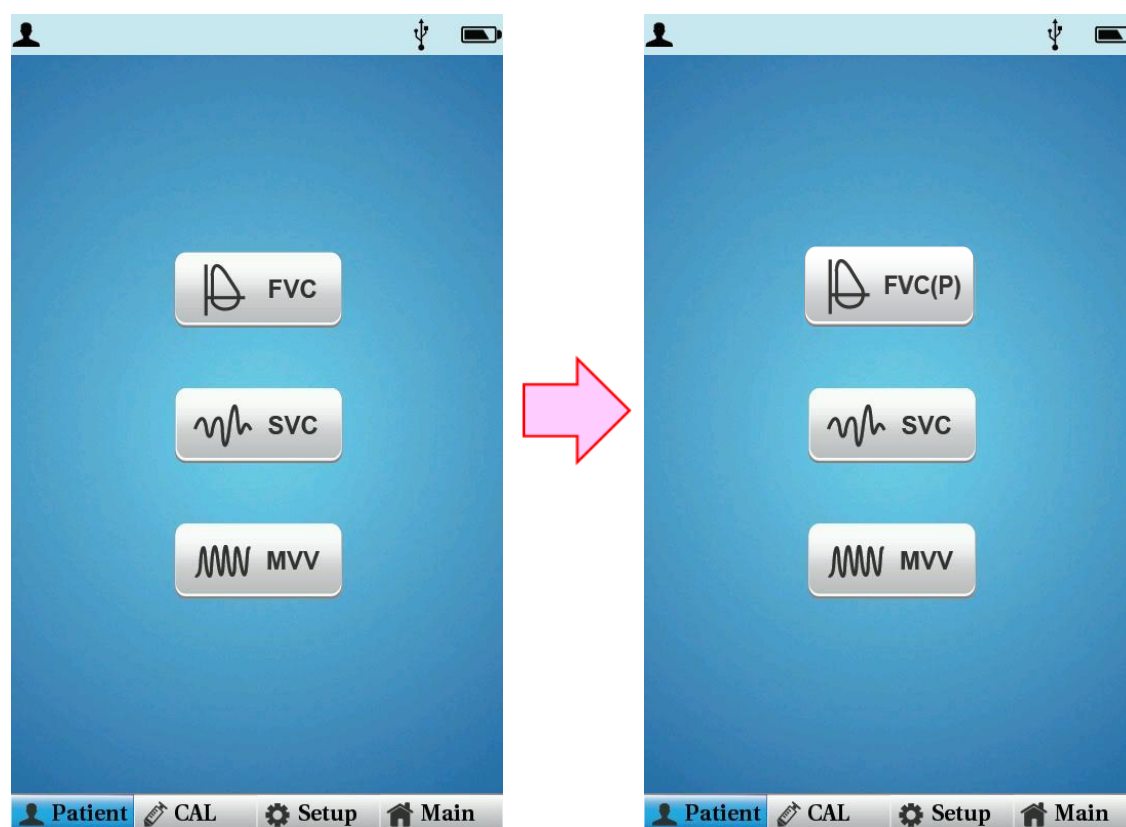

(5) The test can be conducted in the same way as FVC by selecting "FVC+" menu.

(6) The parameters and graphs of pre-administration (Base) and post-administration (Post) can be compared if the results of measurement are printed.

(7) You can see "FVC+" displayed on the data list menu if you press the "Exit" button and save the data. "FVC+" displays the saved data showing the results of the test conducted twice, before and after the administration of medicine.

## Note

- If test needs to be performed twice, i.e. before and after medication, set up as [ Setup → SPIRO → FVC Post → On ] before use.
- Select the Patient Information Entry mode followed by the "New" button in the Patient Information Entry window to go back to the initial test screen if you want to test a new patient with "FVC(p)" displayed on the main screen of the Spirometer. At this time, the previous patient information can be initialized only if you select "New" from "Patient Information" and enter the patient information.

# SpiroCare Operation Manual

## - FVC+ Test Print Form

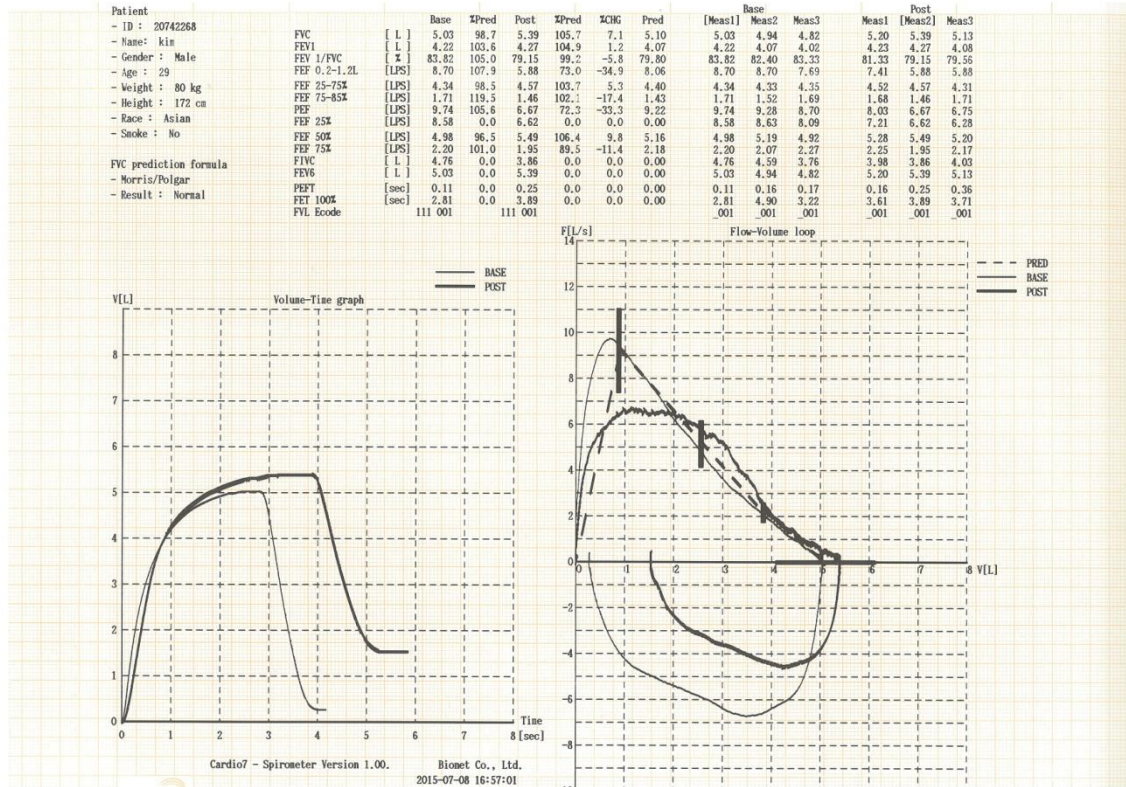

## 4) SVC(Slow Vital Capacity) TEST

If you select "SVC" in the initial menu and press rotary key or touch the touchscreen, the machine will begin to take a "SVC" measurement.

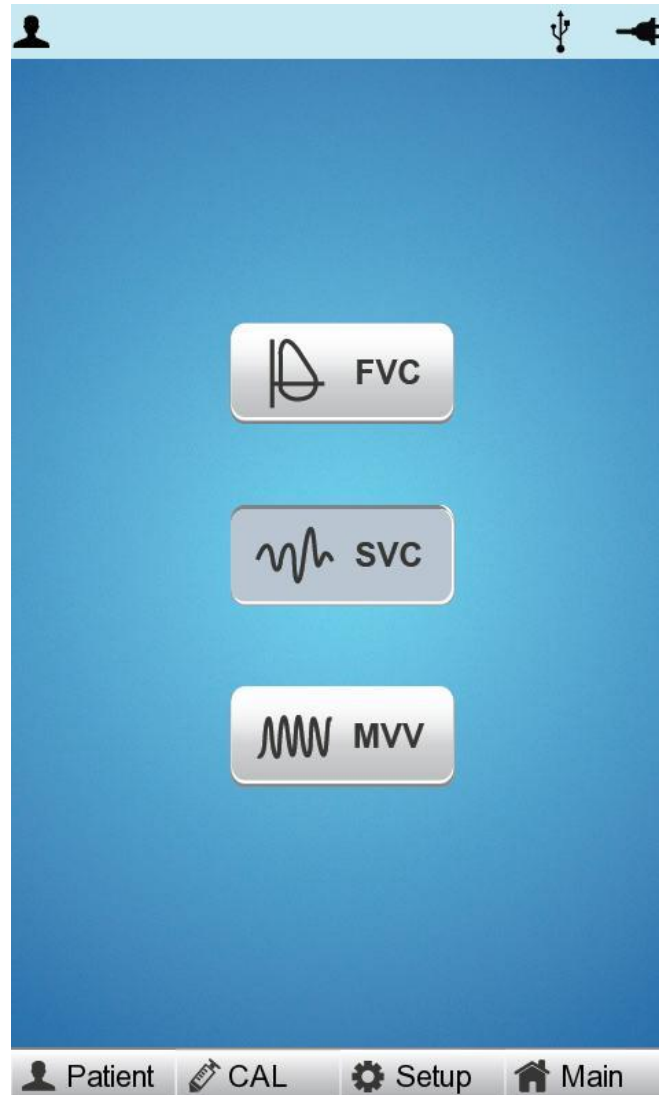

Put the mouthpiece installed the handle on patient lips, and presses the "Start" button. After the start alarm, hold the mouthpiece with lips and breathe out to begin.

To ensure accuracy, measurement must be carried out exactly according to the procedure described below.

## < How to breathe in times of SVC measurement >



**1) Take normal breaths at least four times or more.**  
If the machine senses four or more normal breaths, it beeps.



**2) Exhale as much volume as possible to the end, slowly.**  
(RV level)

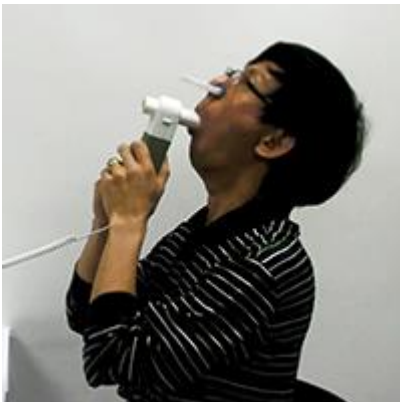

**3) Inhale as much volume as possible to the end, slowly.**  
(TLC level)

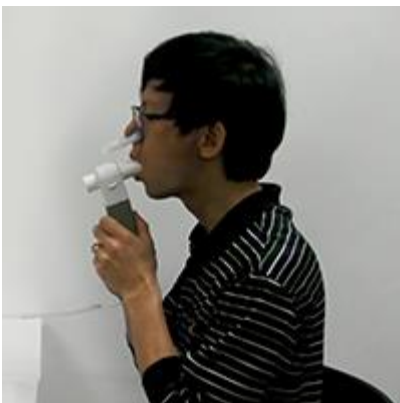

**4) Return to normal breathing.**

# SpiroCare Operation Manual

If you breathe in above-mentioned order, a graph of breathing speed (F-T) appears first. If you take a small normal breath while taking a big breath according to step 2 to 3, a big graph would be re-drawn on screen.

Speed in the positive side(F[L/s]) of the screen indicates exhalation and that in the negative side inhalation. If you press "ESC" key while you are taking measurement, the machine would stop taking the measurement, and return to spirometer initial menu screen.

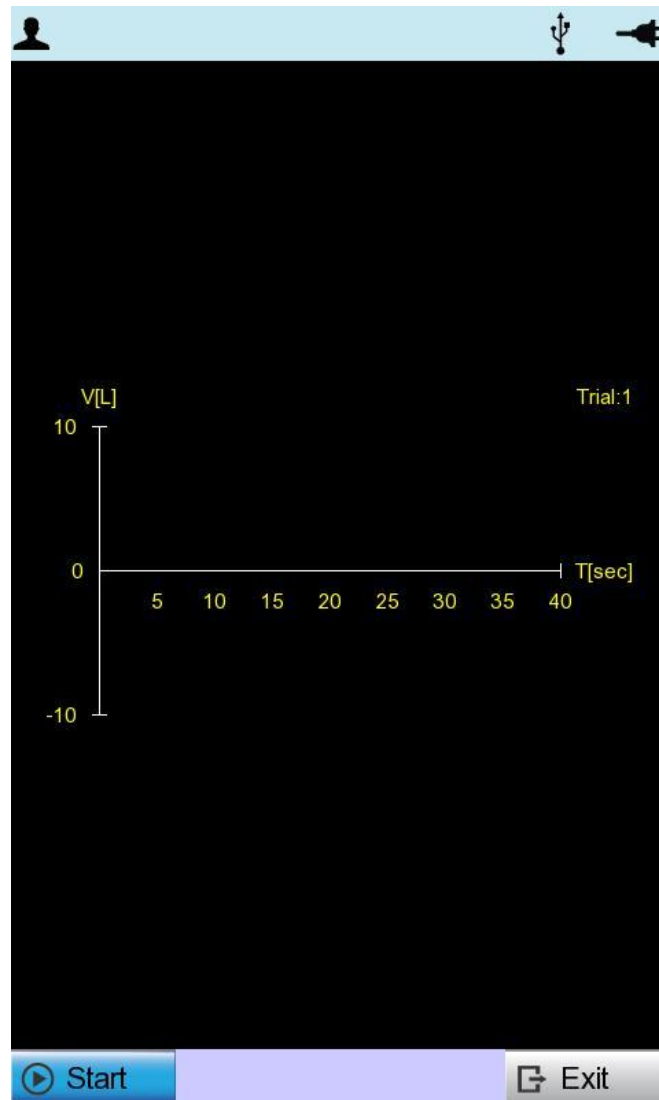

# SpiroCare Operation Manual

Once the measurement is finished, a graph(V-T) showing change in volume of lungs to passage of time is drawn like the screen shown below.

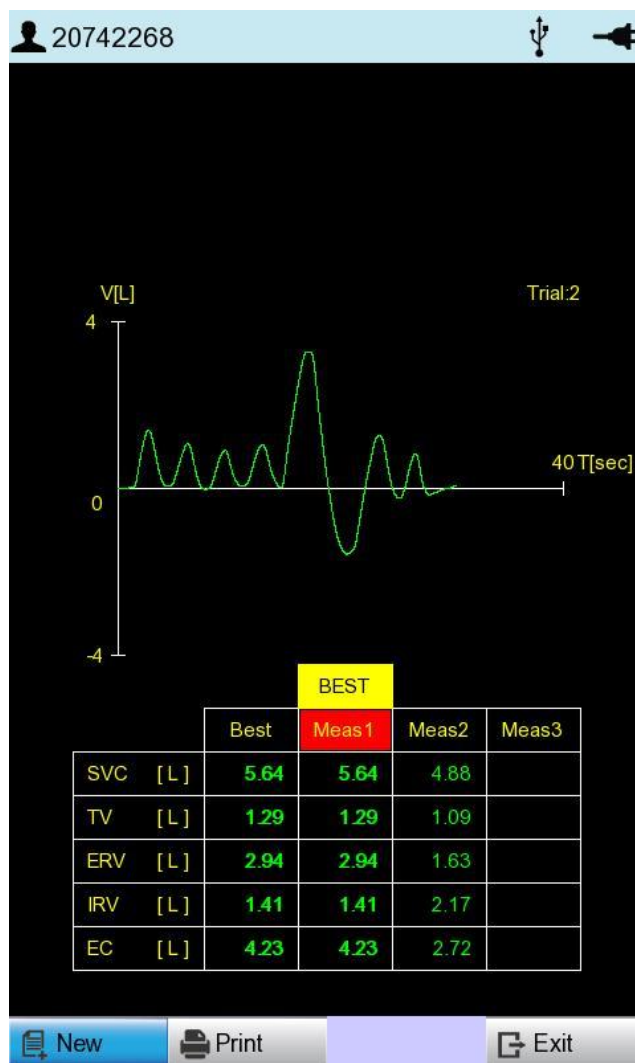

The best choice of SVC for automatic diagnosis is determined by the maximum value of SVC.

The 'Best', 'New', 'Print' and 'Exit' menus are used the same way as for FVC test measurements.

# SpiroCare Operation Manual

## - SVC Test Print Form

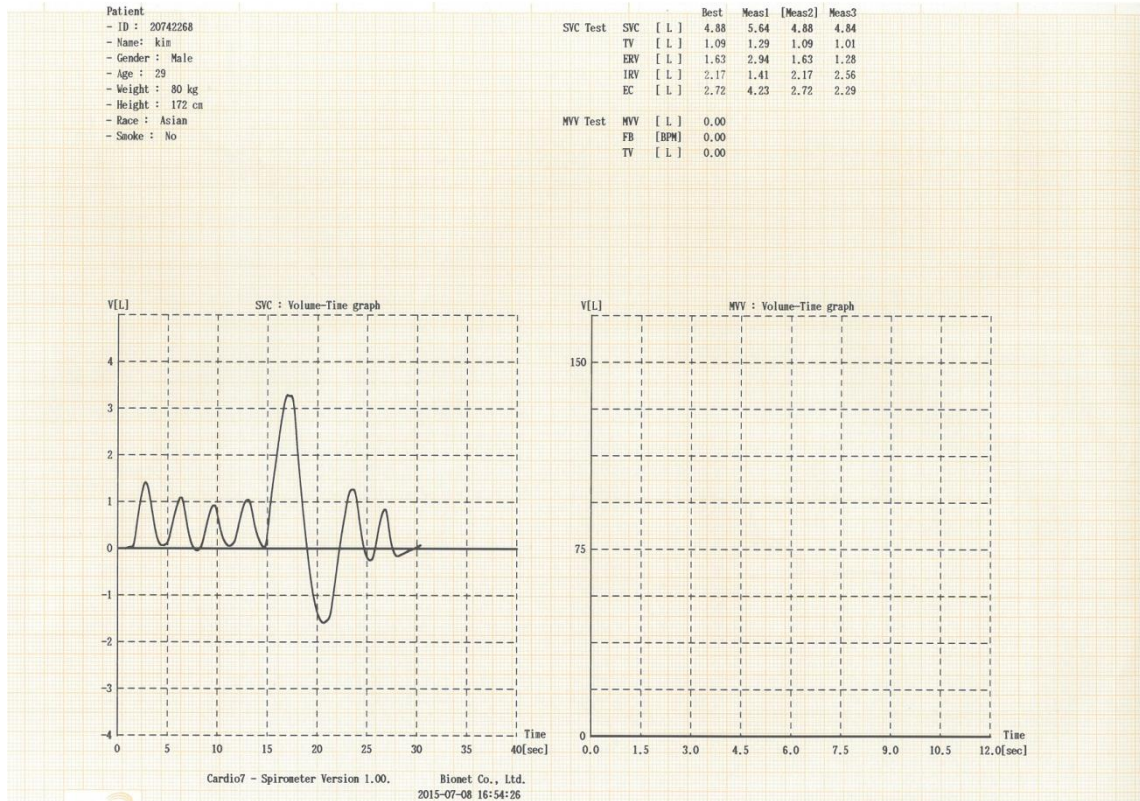

## 5) MVV(Maximum Voluntary Ventilation) TEST

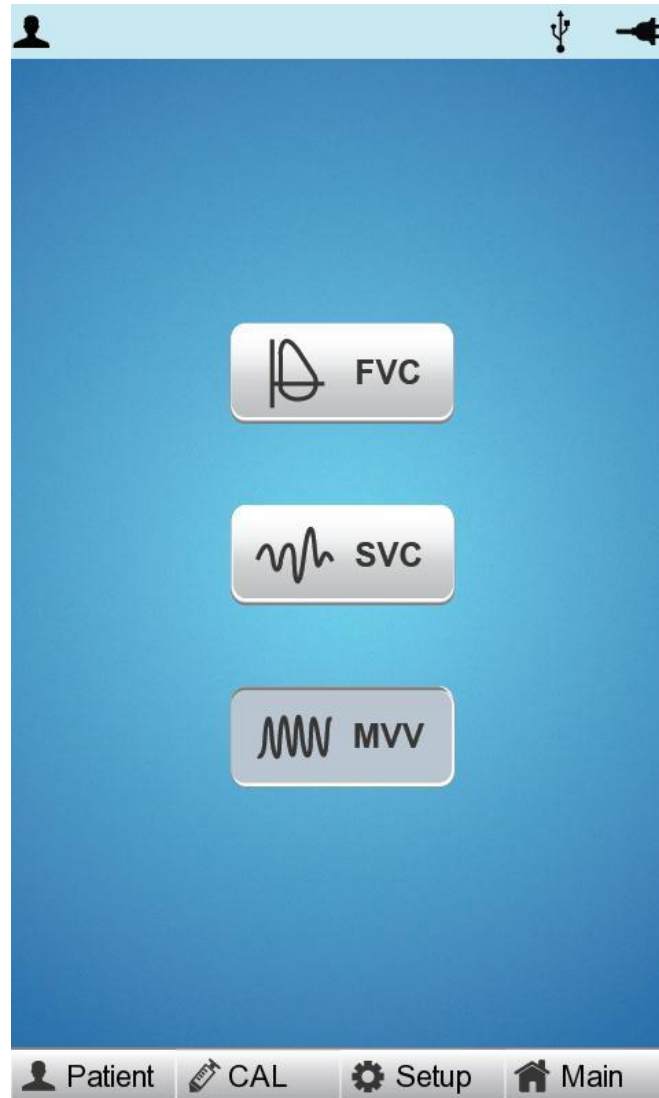

If you select "MVV" in the initial menu and press rotary key or touch the touchscreen, the following screen appears. Press "Start" to begin taking the first "MVV" measurement.

# SpiroCare Operation Manual

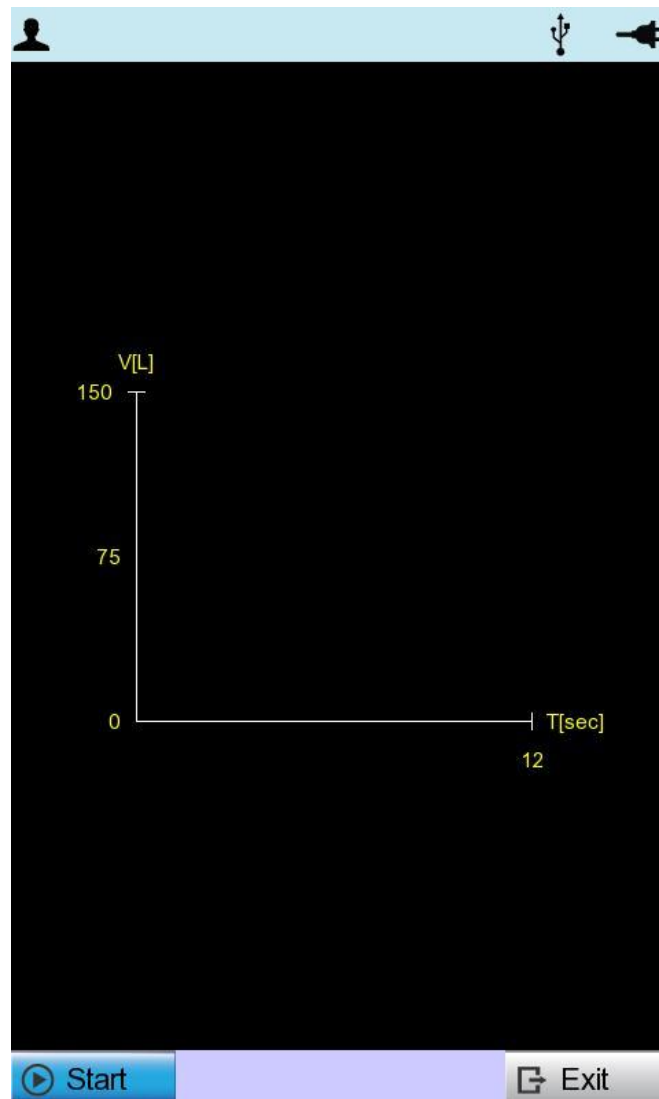

Put the mouthpiece installed in the handle on patient lips, and press the “Start” button. After the start alarm, hold the mouthpiece with lips and breathe out to begin.

To ensure accuracy, measurement must be carried out exactly according to the procedure described below.

## < How to breathe for MVV measurement >

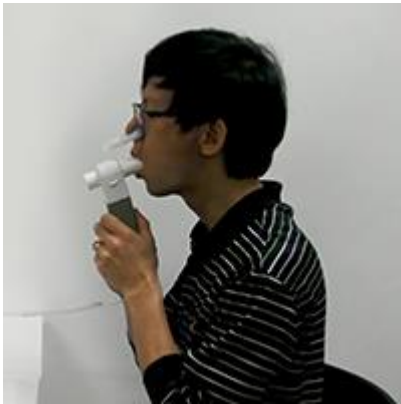

- 1) Begin to take measurement of vital capacity.
- 2) Instruct the patient to breathe as fast and much as possible. (MVV)
- 3) After a specified measurement time (T-MVV) has passed, the machine concludes the measurement, and shows the resulting values on the screen. (Set as T-MVV=12[sec] in advance)
- 4) Return to normal breathing.

If the patient performs "MVV" test following the above orders, Volume-Time graph would be drawn on the screen. The volume shown here is the result of adding amounts of inhaled and exhaled air.

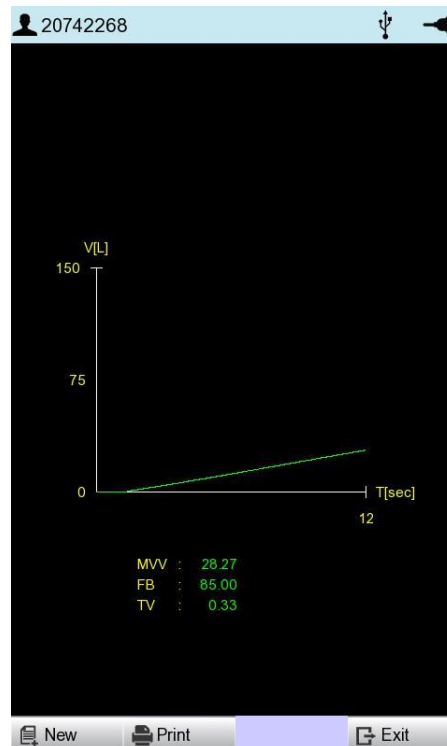

The measurement is automatically completed 12 seconds after the predetermined duration of measurement (T-MVV), and the results are displayed on the screen. MVV, respiratory cycle (FB), and Total Ventilation (TV) are computed and displayed on the upper side of the screen. If the user presses "Stop" during the measurement, the test stops, and the initial screen for the "MVV" test is displayed.

# SpiroCare Operation Manual



The "New", "Print" and "Exit" menu can be used in the same way as in the FVC test.

# SpiroCare Operation Manual

## - MVV Test Print Form

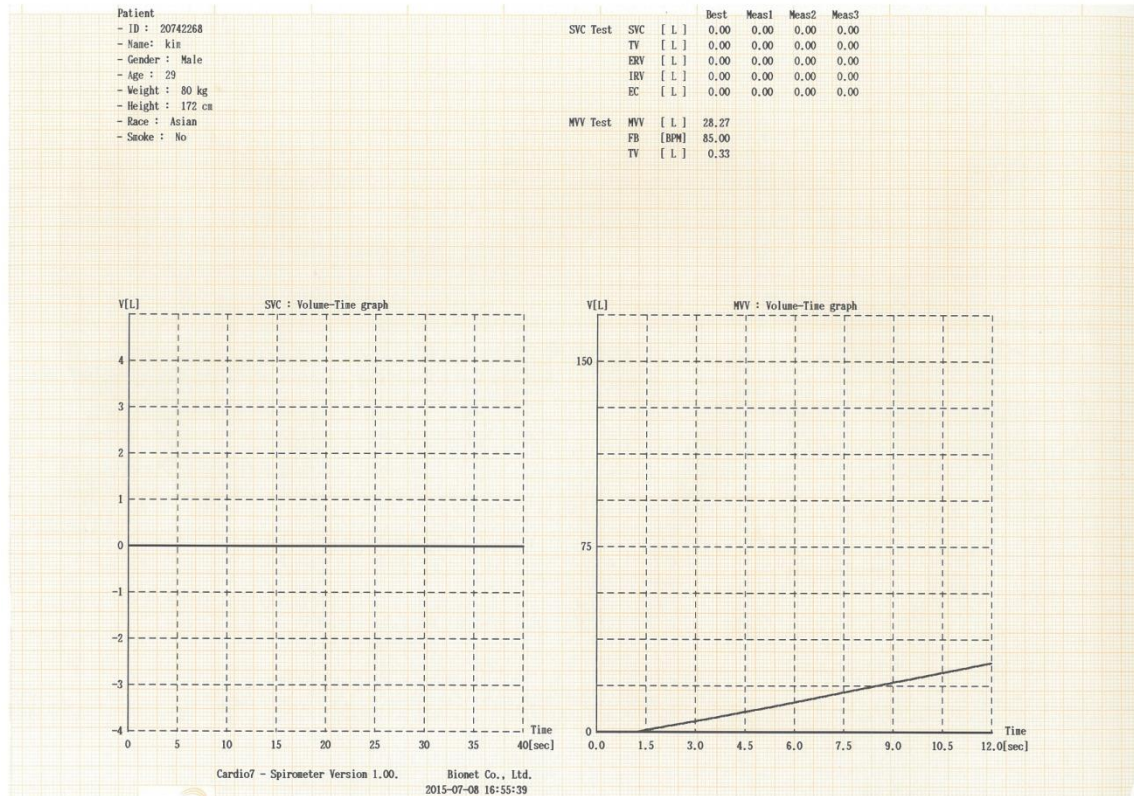

## 6) Calibration

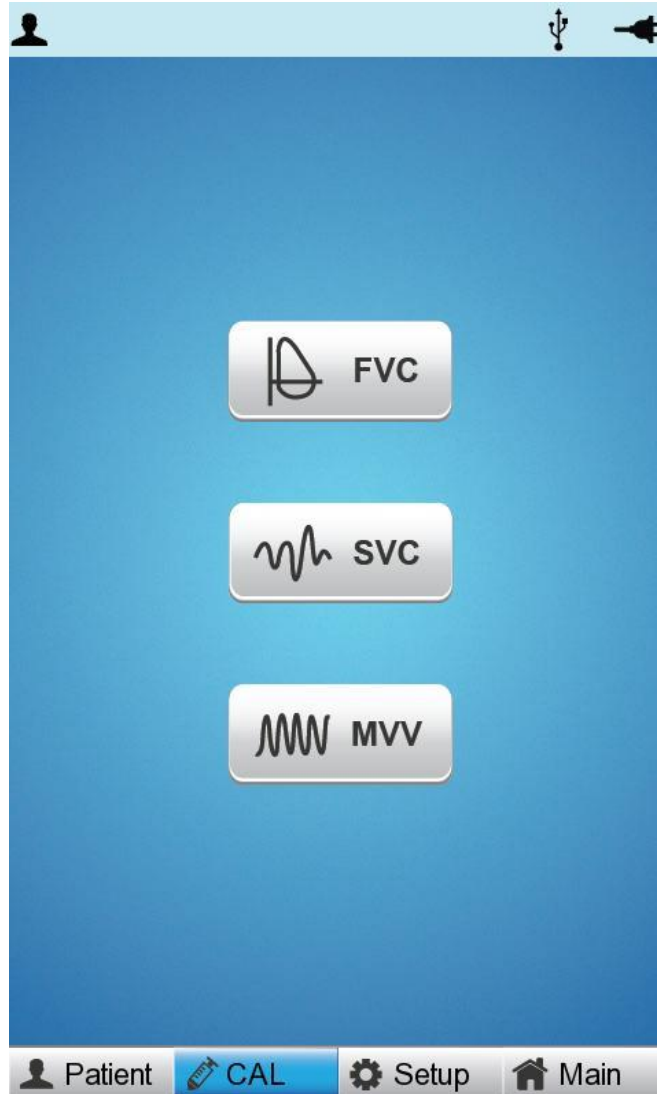

Select 'CAL' from the sub-menu and press the Rotary key, or tab to the 'CAL' field to see the Calibration Main menu screen as below.

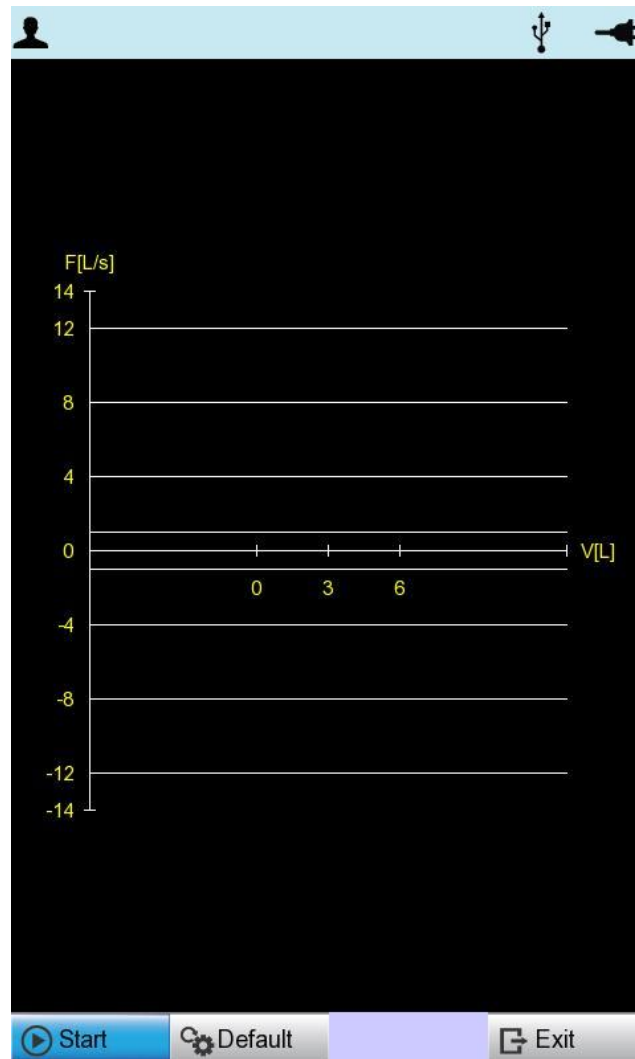

Calibration should be conducted in the following order: Violation of order might cause error in measurement.

- 1) Connect conductor of measurement part of spirometer to the main body.
- 2) Connect the mouthpiece installed in the spirometer handle to mouth of syringe.  
Insert it tightly to prevent any leakages.
- 3) Press start button. If the machine is ready for the calibration, it beeps.
- 4) Move syringe handle back and forth ten times each.  
Make sure to move the handle after you hear the machine beep.
- 5) Decide whether to apply the calibrated setting to the device.

## Calibration

Correction can be made by pressing the “Start” button once you are ready for correction. The screen below appears if the syringe handle is moved back and forth. To ensure accurate correction, move the handle only after a beeping sound is heard.

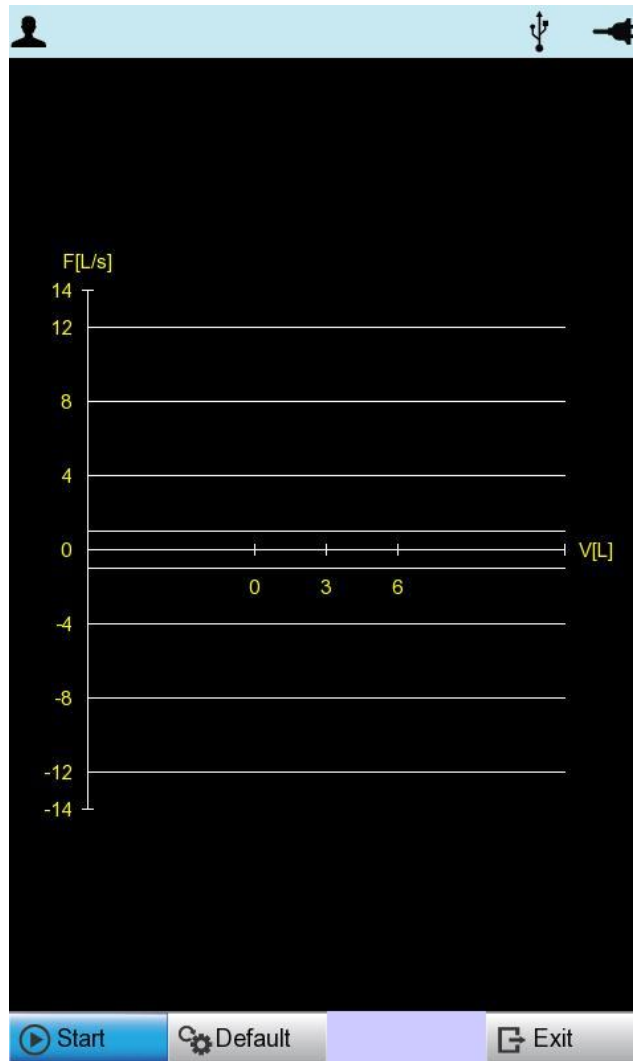

# SpiroCare Operation Manual

A graph as the visual representation of flow and volume will be drawn along the movement of the syringe. The results of previous volume measurement and error (%) will be displayed on the screen as shown below if the syringe makes the round trip 5 times. Press the "Exit" button and return to the initial calibration menu to start again if no beep sound is heard each time.

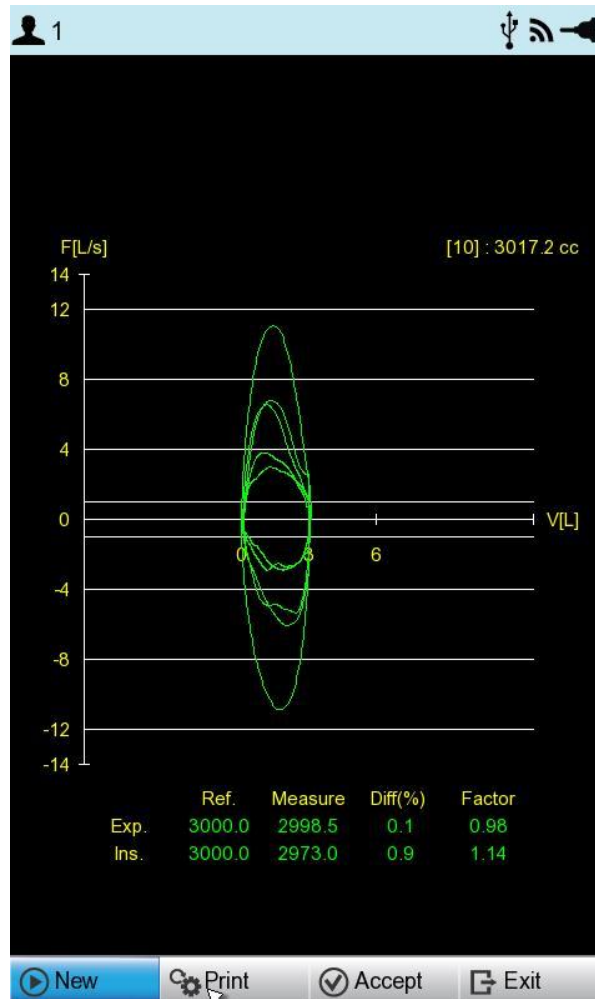

Select 'Print' from the menu to output Calibration result.

Select 'Accept' from the menu to apply Calibration result to the device.

Select 'Exit' from the menu to end Calibration and exit to the top menu.

## Note

- It is recommended that the revision of the lung capacity measuring instrument should be practiced each quarter and if the temperature and atmosphere greatly changes the test should be essentially practiced.
- Re-practice the revision if your revision result does not belong to  $\pm 3\%$  and redo the test until your revision result belongs to  $\pm 3\%$ .
- When calibrating with a syringe, a graph of at least more than  $\pm 0.5$  L shall be drawn and it is recommended that the graph be drawn at least once within the range of  $\pm 4$  L,  $\pm 8$  L and  $\pm 12$  L.

# SpiroCare Operation Manual

## - Calibration Print Form

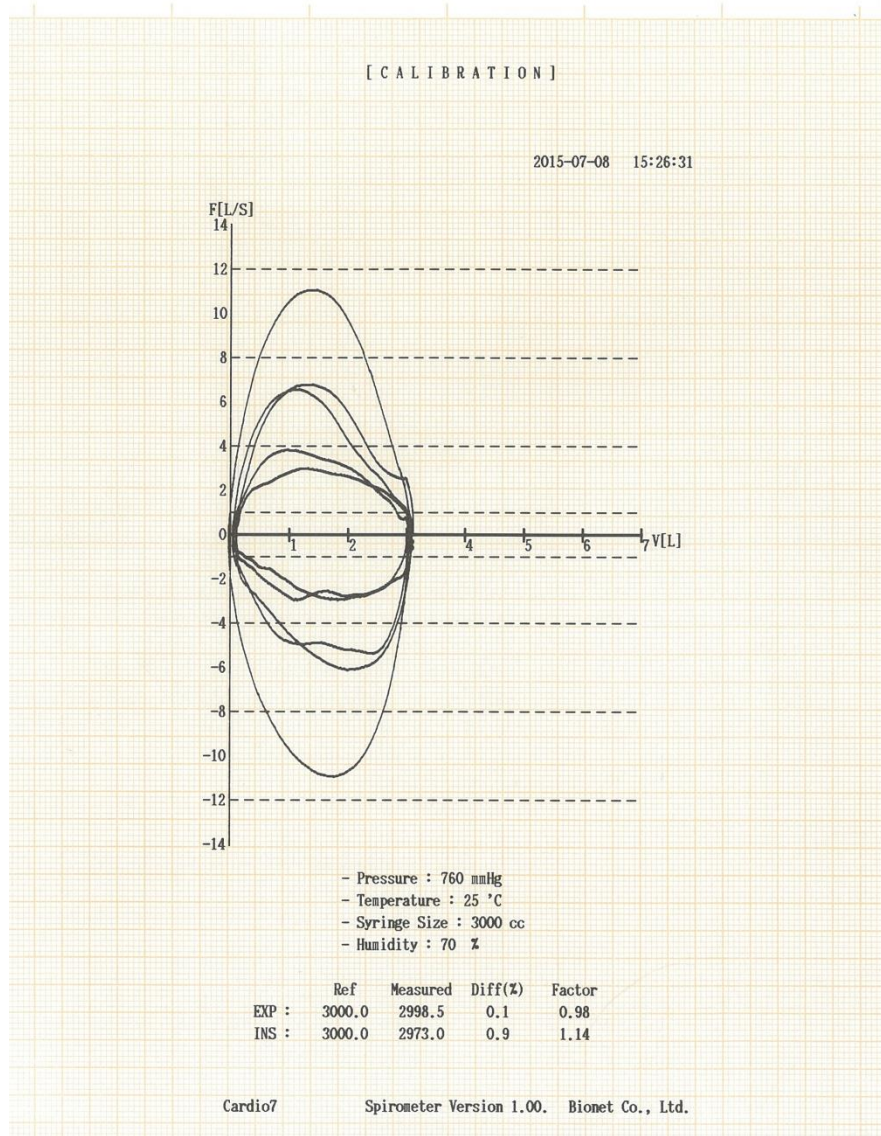

## 7) System Setup

System Setup menu is used to set up device-related details. From the initial screen of Spirometer, select 'SETUP' by using Rotary switch or tab.

System Setup menu consists of Basic Setup, Network Setup, Hospital Setup, Spiro Setup, Calibration Setup and Service Setup and you can change the setting at each window. The main page shows Basic Setup.

After finishing the settings, press 'OK' to save the new information or press 'Cancel' to cancel it. You can choose 'Exit' or 'ESC' button to exit from the System setup menu.

'Default' button is used to default every setting.

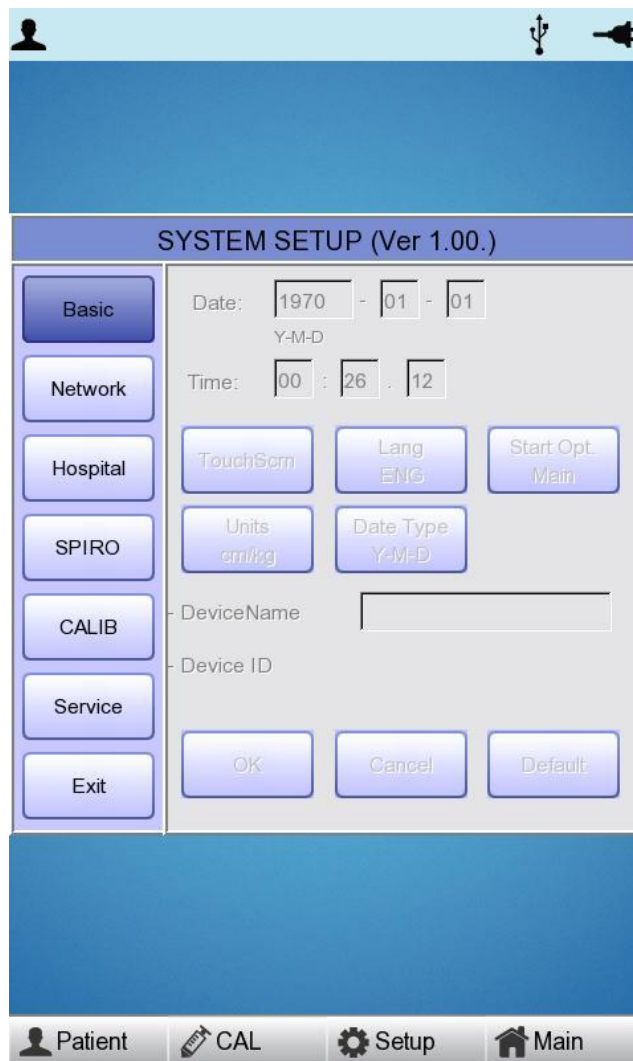

## Basic Setup

When choosing Basic menu at the left side of the Setup page, you will see the page for Basic Setup.

Basic Setup consists of Date, Time, Touch screen, Start Option, Unit, Date Type and Device Name menus.

### Setup date and time

After selecting System Setup, click the Basic button to focus on the 'Date' item.

By using the touch screen or rotating the rotary switch, choose the Date (yyyy/mm/dd) or Time (hr/min/sec), then the keypad will show up. You can set up the information by using this keypad.

The Focus will go 'year → month → day → hour → minute → second' consecutively.

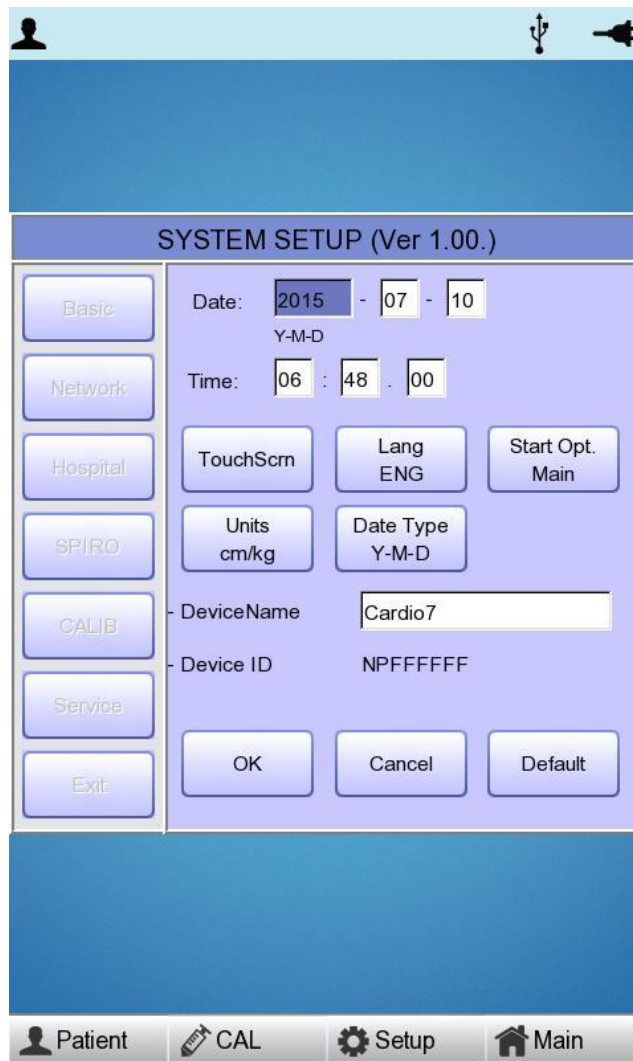

## Touch Setup

This is a menu to set up the coordinates of the touchpad. When selecting the 'Touch' menu at the Basic Setup page, setup page will disappear and the coordinates for setting calibration will appear as shown below. Follow the instructions shown on the screen, and then the coordinates will be set up.

Please input the information in the right place, otherwise the touchpad may not work properly.



### Note

When the user selects the Touch Setup menu, all windows will disappear and the touch screen setup will start. No keys will be operational until the Touch Setup is complete.

## Language

As shown below, when selecting 'Language menu at the Basic Setup page, you can choose the language among

English, French, German, Italian, Korean, Polish, Portuguese, Rumanian, Russian, Spanish and Turkish.

Select the language you want to use and click the OK button and then you can use the service in the chosen language.

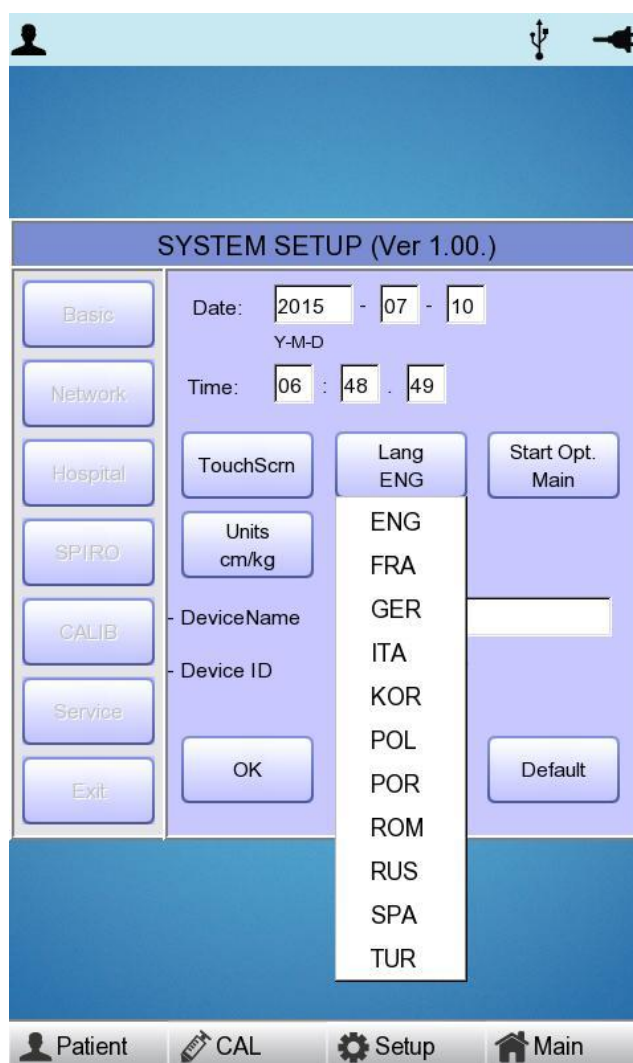

### Note

Patient information previously entered will be initialized if the language preference is changed.

### Note

If language preference is set as "KOR," only the menu on the LCD screen will be shown as Korean, whereas the output will be in English when printing out.

## Start Option

You can set up the index page shown at the time of initial boot up, according to the common dialog.

When clicking the 'Start Option' button, a small menu window will appear and you can select the initial page you want to have among MAIN, FILE, WORKLIST, ECG, SPIRO.

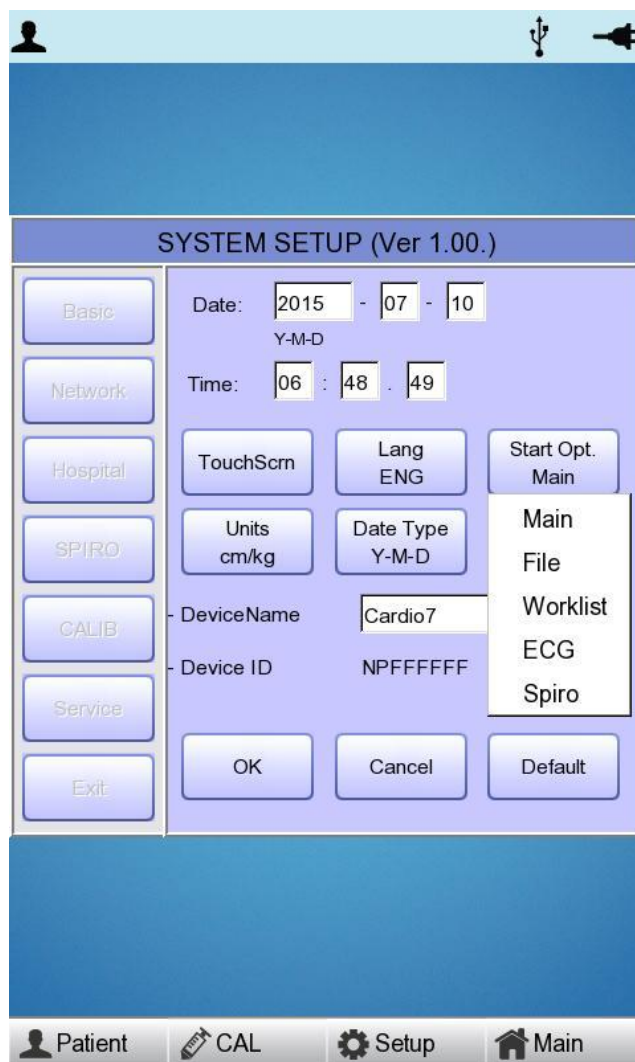

# SpiroCare Operation Manual

## Units

This menu is to select the units for height and weight of the patient. When you click 'Units' button, cm/kg or Inch/Lbs will be shown.

If you select Inch/Lbs unit, the patient's height information will be expressed in \*\*\* Ft (Feet) \*\*\* Inch.

The screenshot displays the 'SYSTEM SETUP (Ver 1.00.)' interface. On the left is a vertical menu with buttons for 'Basic', 'Network', 'Hospital', 'SPIRO', 'CALIB', 'Service', and 'Exit'. The 'SPIRO' section is active, showing a sub-menu with 'Units' selected (displaying 'cm/kg'), 'Date Type' (Y-M-D), 'TouchScrn', 'Lang' (ENG), and 'Start Opt.' (Main). The main area shows 'Date: 2015 - 07 - 10' (Y-M-D), 'Time: 06 : 48 : 49', 'DeviceName: Cardio7', and 'Device ID: NPFFFFFF'. At the bottom are 'OK', 'Cancel', and 'Default' buttons. A bottom navigation bar contains 'Patient', 'CAL', 'Setup', and 'Main' icons.

## Date Type

As seen in the figure below, the date format for printout can be selected by choosing 'Date Type' from the Basic Setup menu. Choose the date format to be used, and then click the 'OK' button; the selected date format is seen on the output.

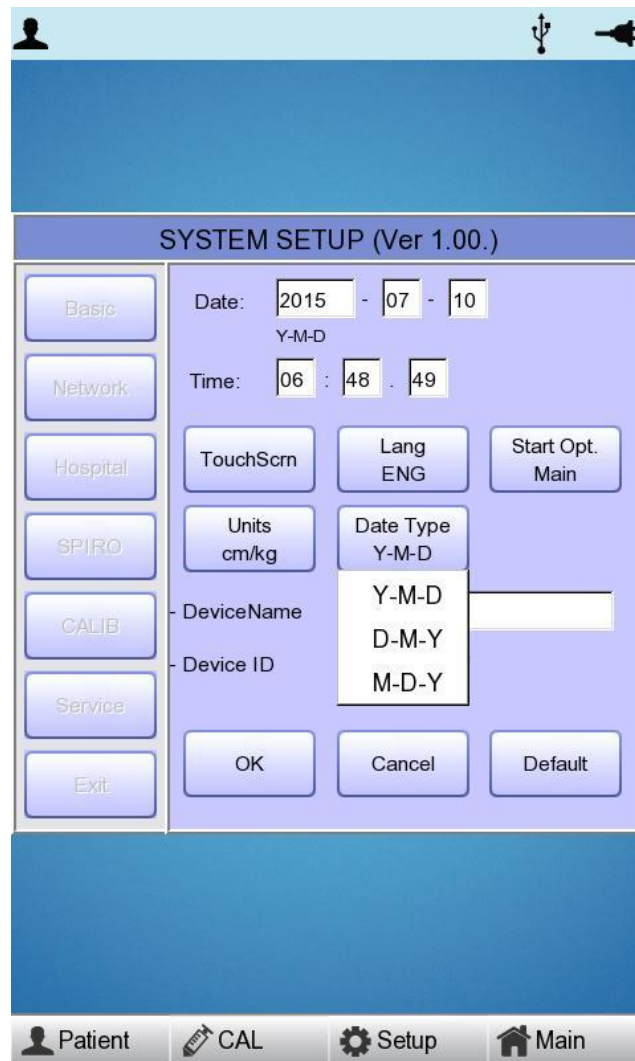

## Device Name Setup

'Device Name' refers to the name of the device. The user can input the name of the device in order to distinguish devices on PC easily.

'Device ID' cannot be revised by the user as it is a unique ID of the device, and is used to identify devices on a PC. 'Device ID' is automatically set for easy identification of devices on the connected PC; therefore, it cannot be revised by user.

## Network Setup

When connecting the equipment with LAN to interface with the outside PC, network setup is needed. Network IP is required and DNS is not used.

When selecting the Network menu at the left side of the System Setup page, Network Setup page will show up at the right side.

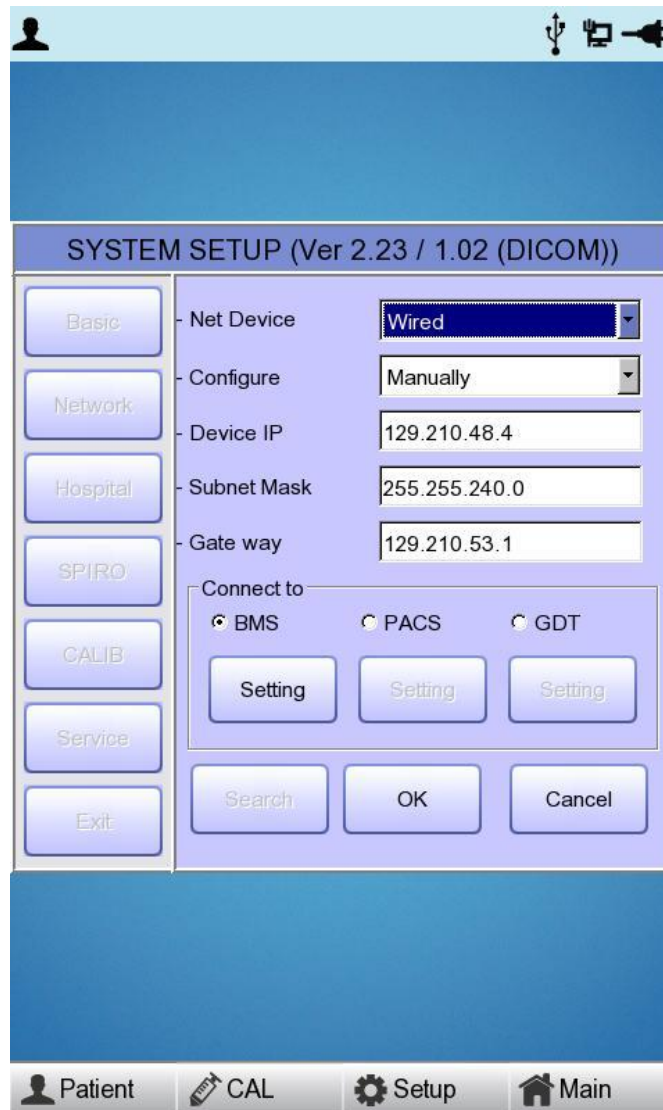

The mode of network connection can be selected as Wired or Wireless in 'Net Device' setup.

The automatic IP(DHCP) or fixed(Manually) can be selected through the 'Configure'.

If the Configure is setup as automatic IP(DHCP), the Device IP, Subnet Mask, Gateway value is received automatically from the DHCP server on your network. If the Configure is set to manually, the user has to enter the Device IP, Subnet Mask, Gateway directly.

When selecting one of the 'Device IP', 'Subnet Mask', 'Gate Way', the keypad will show up. Then, input the information required and press 'OK' button to save or 'ESC' to cancel the information.

# SpiroCare Operation Manual

When selecting each of the 'Device IP', 'Subnet Mask', 'Gate Way', the keypad will show up. Then, input the information required and press 'OK' button to save or 'ESC' to cancel the information.

It allows selecting the server which is available to link with the equipment in the 'Connect to' menu.

After selecting the type of interlocking server, select the 'Setting' button; an appropriate setup window to the choice of server will be displayed.

## Note

- When setting up the connection to the PACS Server, the Device IP should be entered manually (manual IP input) and used. When setting up as DHCP, the Device IP can be changed; if the setting is different from the Device IP registered in the PACS Server, it may prevent interworking with the server.

## BMS Server Setting

IP setup on BMS Server-installed PC can be performed by choosing either Automatic IP (DHCP) or Fixed IP (Manually) in 'Configure' setup.

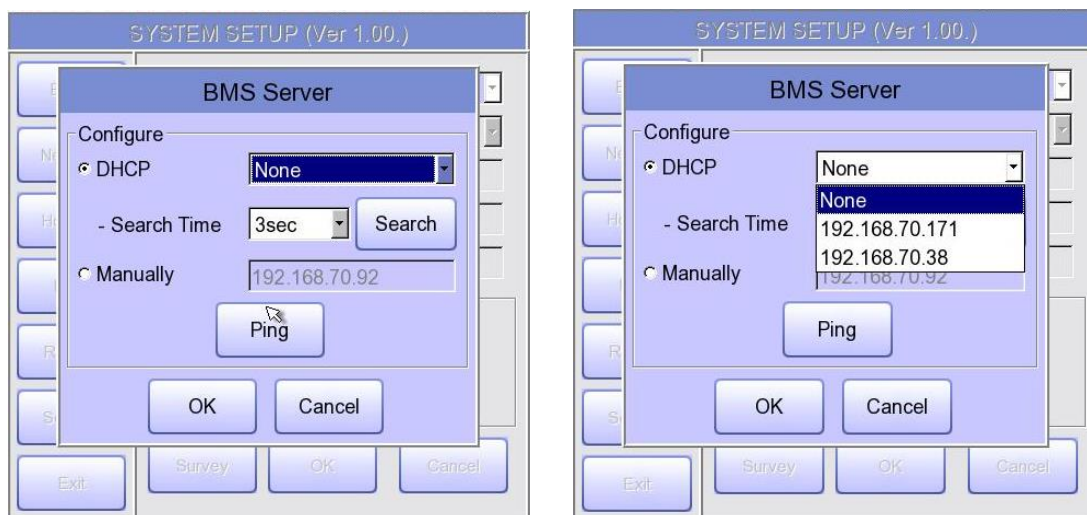

If 'DHCP' is chosen, the IP of the BMS Server-installed PC will be shown on the input box. Choose the IP of the PC you intend to connect as the IP of a BMS Server-installed PC; If multiple IPs are displayed, choose one belonging to the PC to connect. At that time, IP will be shown on the input box only if BMS Server is running on the PC. If no IP of the intended BMS Server to connect is shown on the input box, choose 'Search' button to conduct an additional search. If no IP of the intended BMS Server to connect is shown on the input box, choose 'Manual' mode to perform manual input.

Upon completion of BMS Server IP setup, the Ping Test can be conducted to check successful network connection. If choosing 'Ping' button, "Ping : 100% Succeeded" message will be shown for a successful connection, whereas "Ping : Failed" message will be shown for connection failure.



### Note

- Wired usage is recommended for a BMS Server-installed PC network.
- When setting BMS Server, directly enter the IP of the BMS Server-installed PC by selecting "Manually" if searching with DHCP has failed.

## PACS Server Setting

When selecting the PACS Server, the additional information should be set through the Settings Menu.

The screen for related settings such as the AE Title, IP and Port of SpiroCare, Worklist Server and Store Server will appear.

**PACS SETUP**

Cardio7  
AE Title:  Port:

Worklist Server  
IP:  Port:   
AE Title:

Store Server  
IP:  Port:   
AE Title:

Modality  
ECG:  Spiro:

When the input window of each item is selected, the keyboard window will appear; enter the applicable contents.

When entry is completed, click the "Verify" button so that the connection between the Worklist Server and the Store Server can be confirmed.



# SpiroCare Operation Manual

When successful, the "Verify : Success" message will appear; when it has failed, "Verify : C-Echo Failed" will appear.

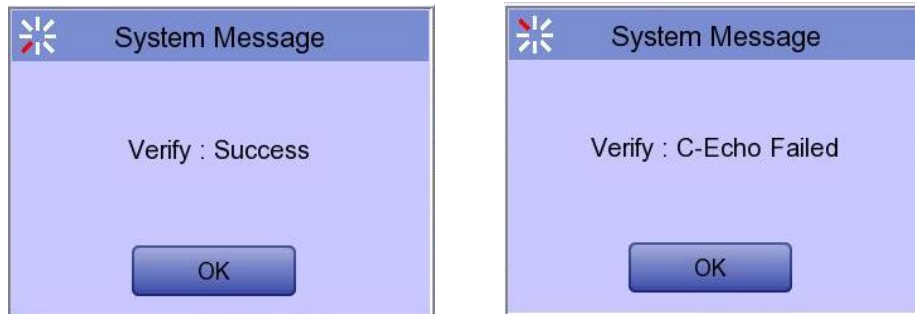

Set the PACS option by pressing the More button when connection to the server is confirmed.

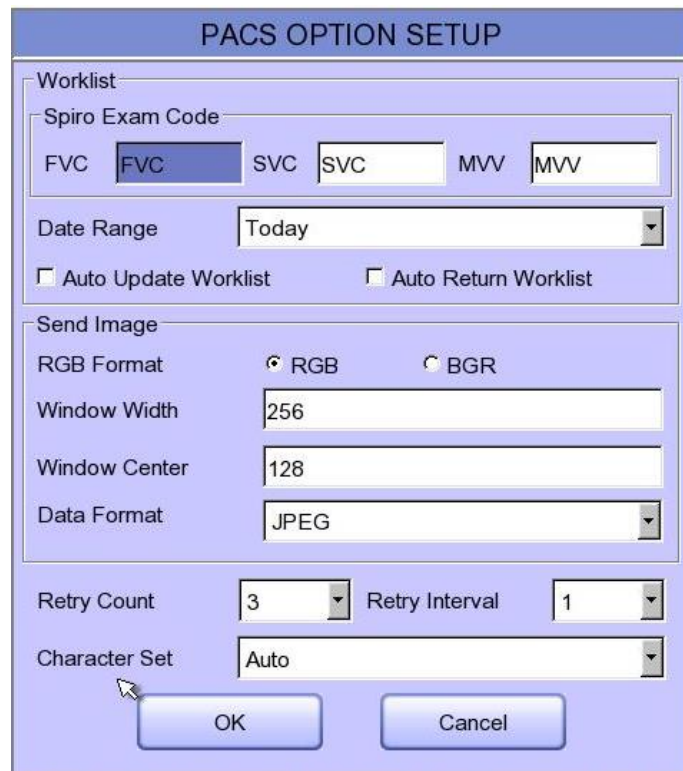
A screenshot of the 'PACS OPTION SETUP' dialog box. It has several sections: 'Worklist' with 'Spiro Exam Code' (FVC, SVC, MVV), 'Date Range' (Today), and checkboxes for 'Auto Update Worklist' and 'Auto Return Worklist'; 'Send Image' with 'RGB Format' (RGB, BGR), 'Window Width' (256), 'Window Center' (128), and 'Data Format' (JPEG); 'Retry Count' (3) and 'Retry Interval' (1); and 'Character Set' (Auto). 'OK' and 'Cancel' buttons are at the bottom.

## Spiro Exam Code

Enter the Exam Code of FVC, SVC and MVV for the Spiro test.

## Data Range

The range of dates when the worklist is brought can be set at the Worklist Server. You can choose appropriate one from the options such as "Today(today-today)," "Yesterday," "Tomorrow" and "One Week".

The screenshot shows the 'PACS OPTION SETUP' dialog box. The 'Date Range' dropdown menu is open, displaying three options: 'Today', 'Yesterday ~ Tomorrow', and 'One Week'. The 'Today' option is currently selected. Other settings in the dialog include: Spiro Exam Code (FVC, SVC, MVV), Auto Update Worklist (unchecked), Send Image (checked), RGB Format (radio buttons for RGB and BGR), Window Width (256), Window Center (128), Data Format (JPEG), Retry Count (3), Retry Interval (1), and Character Set (Auto). The dialog has 'OK' and 'Cancel' buttons at the bottom.

## Auto Update Worklist

If you tick the Auto Update Worklist, the Worklist update will be run automatically whenever you enter the Worklist screen.

## Auto Return Worklist

If you tick Auto Return Worklist, data will be transferred to the PACS Server and the Worklist screen will re-appear automatically by using the Exam button after selecting the patient to measure, or by using the NETWORK key or AUTO key after selecting the patient to measure.

## RGB Format

Select the RGB Format when converting the image to be transferred to the PACS Server. The basic setting shall be "RGB"; if the Grid Colour of the transferred file appears as green, it will be converted to the red colour when the "BGR" is set.

## Window Width / Window Center

Set the Window Width and the Window Center for the file to be transferred to the PACS Server.

If the image of the transferred file appears blurred, check the Window Width and Center values which the PACS Server supports, and enter them.

# SpiroCare Operation Manual

## Data Format

Set the data format for the file to be transferred to the PACS Server. You can select either "JPEG," "PDF" or "RAW" after checking the format supported by the PACS Server.

The screenshot shows the 'PACS OPTION SETUP' dialog box. It is divided into several sections:

- Worklist:** Contains 'Spiro Exam Code' with input fields for FVC, SVC, and MVV. Below it is a 'Date Range' dropdown menu set to 'Today'. There are two checkboxes: 'Auto Update Worklist' and 'Auto Return Worklist', both of which are unchecked.
- Send Image:** Contains 'RGB Format' with radio buttons for 'RGB' (selected) and 'BGR'. Below are 'Window Width' (256) and 'Window Center' (128) input fields. The 'Data Format' dropdown menu is open, showing 'JPEG' as the selected option, with 'PDF' and 'RAW' also visible in the list.
- Retry Count:** A numeric input field set to '3'.
- Character Set:** A dropdown menu set to 'Auto'.

At the bottom of the dialog are 'OK' and 'Cancel' buttons.

## Retry Count

Select the number of Retransmission attempts when a communication error occurs during transfer of data to the PACS Server.

## Retry Interval

Select the interval for Retransmission attempts when a communication error occurs during the transfer of data to the PACS Server.

# SpiroCare Operation Manual

## Character Set

By selecting the Character Set, multiple selections of language are available; it should be selected according to the character set in order to present contents such as patient information by language when transferring a DICOM file to the PACS Server.

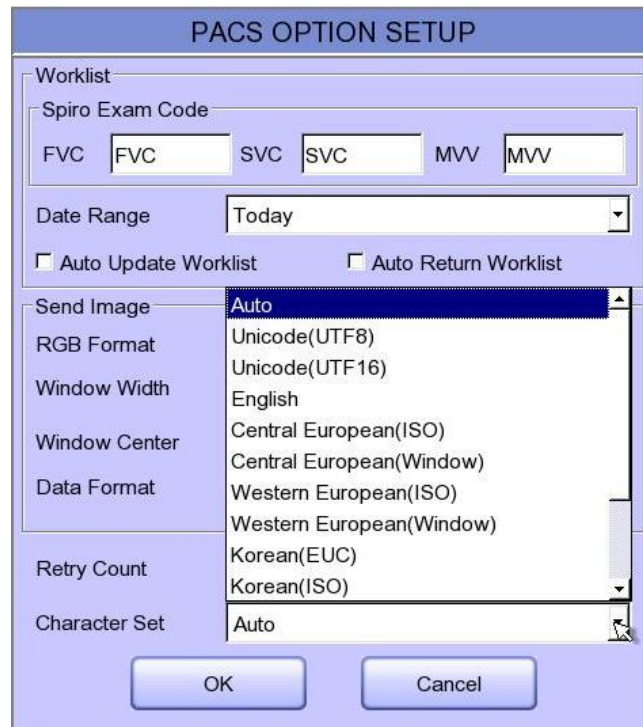

Upon the completion of each setting, press the 'OK' button to save the changes or push the 'Cancel' button or the 'ESC' button of the Operating Panel to cancel them.

## GDT Setting

When selecting GDT, additional information should be set through the Setting menu. It shows the menu screen for related settings such as Work type, GDT Directory, Component name, File name, and Image type.

**GDT SETUP**

Work Type  
 Server  Client

Directory  
Directory Path :  
//192.168.50.162/GDTShare  
User ID : root  
Password : bio2net  
Date : MMDDYYYY

Component  
Import [EMR,HIS]  
Name : ALBIS  
Short Name : SPM  
Export [Cardio7]  
Name : BIONET  
Short Name : BIO

File Name  
Type : RCVSND.NUM  
File Name : SPMBIO.GDT

Image  
 JPEG  PDF  DICOM

OK Cancel

### Work type

Set how the GDT function of the system works.

- Server: Cardio7 receives requests and commands.
- Client: Cardio7 sends requests and commands.

### Directory

Enter the type format in which the shared folder information and date information to be used by the GDT protocol.

# SpiroCare Operation Manual

## Component

To use GDT protocol, enter the EMR name and abbreviation and the name of Cardio7 and abbreviation.

## File name

Select the name form of the file to be shared by the GDT protocol.

## Image

Select the image format of the data file to share with the GDT protocol.

When the user selects the Input window for each item, a keyboard window appears and the user can type its contents. If the input is completed normally, a message about the connection success is displayed at the top of the screen.

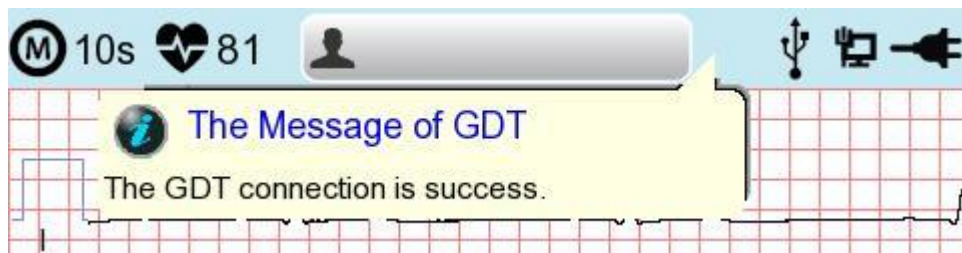

## Wireless Network Setting

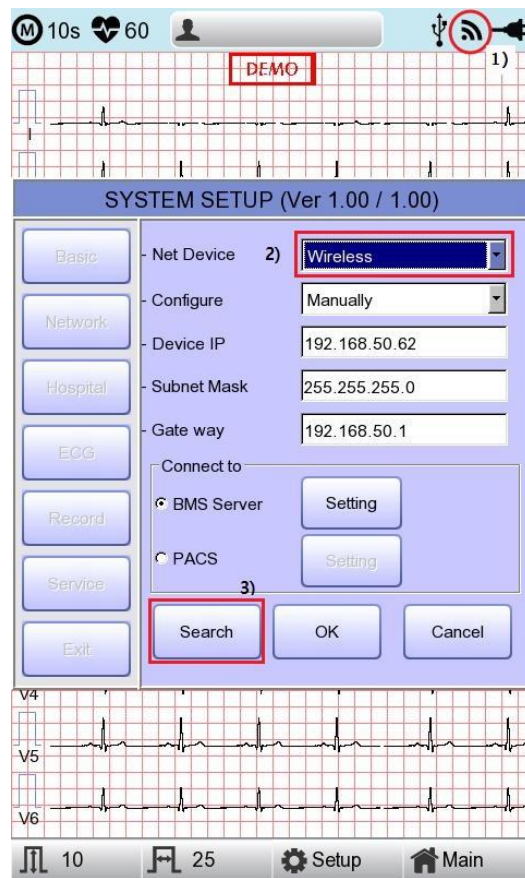

- 1) Connect the USB wireless LAN card to the USB port of SpiroCare and check whether or not the wireless icon (  ) appears in the Status bar on the top of the screen.
- 2) Navigate to System Setup -> Network, and Set the Device as "Wireless". When selection is done properly, the "Survey" button on the bottom will be activated.
- 3) Select the "Search" button to search for the AP. The AP is to be searched automatically when the "Search" button is pressed; the searched AP will appear in the list upon the completion of the search.

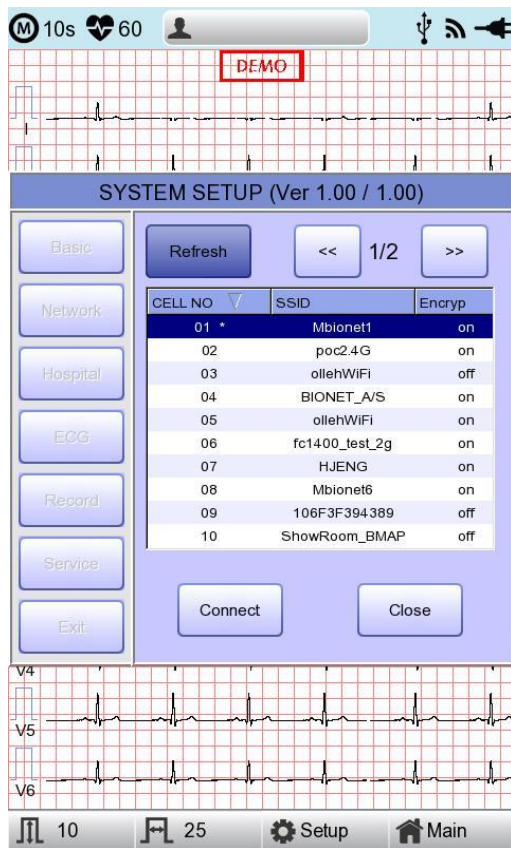

- **Refresh** : AP re-searching
- **<<** : Page up
- **>>** : Page down
  
- **Connect** : Attempting to connect
- **Close** : Closing the window

4) Select the AP to be connected by using the rotary key or touching. Click the "Connect" button. At that time, the security key input window will appear if the "Encrypt" field is "On".

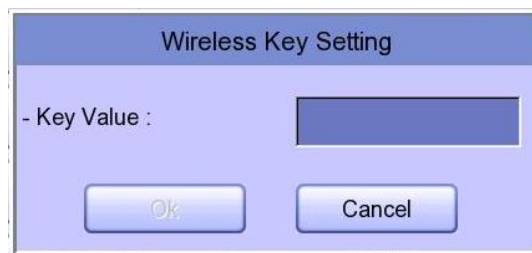

### Note

The user should set the AP Search and Security Key in order to use the wireless network. If there is no security set on the AP to be connected, it will be connected automatically without Security Key setting. In the event that there is an automatic connection to the AP without Security Key setting, the safety of network communication is not guaranteed.

- 5) After clicking the Key Value input line by using the rotary key or touching, enter the security key.
- 6) Upon the completion of input, click the "OK" button; Connection will be attempted and the message describing the connection status will appear.

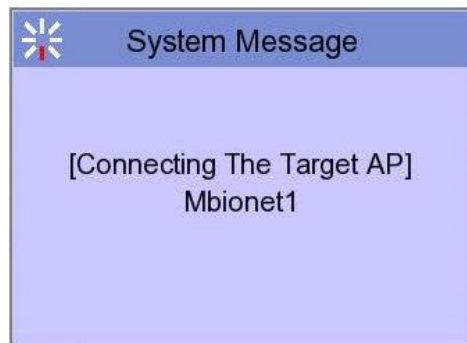

- 7) When the message reporting a proper connection appears, click the "Close" button.



When connection is successful, the wireless icon on the status bar at the bottom of the screen will be changed into .

- 8) If connection fails, connection can be re-attempted by pressing the "Retry" button.  
If connection keeps failing, check the AP and the USB-TO-WLAN status.



# SpiroCare Operation Manual

- 9) When connection with the AP is successful, set the Device IP, Subnet Mask, Gateway, etc. by selecting manually or Configuring with DHCP.  
Refer to the Network Setup part of the User Manual for more details.

## Note

It is recommended to use English for the name of the AP wireless network (SSID). If it is entered in Korean or other languages, Mojibake or illegible characters can appear.

## Note

- It is recommended connecting up to eight units to the same network under normal AP status.
- Due to the nature of wireless, connectivity may be poor depending on the environment.

## Hospital Setup

When selecting the 'Hospital' menu at the left side of the Setup page, Hospital Setup page will show up at the right side.

You can input the names of the hospital and doctor.

When clicking the area to input the information, the keypad will show up. Then you can input the information required and press OK button to save or ESC to cancel the information.

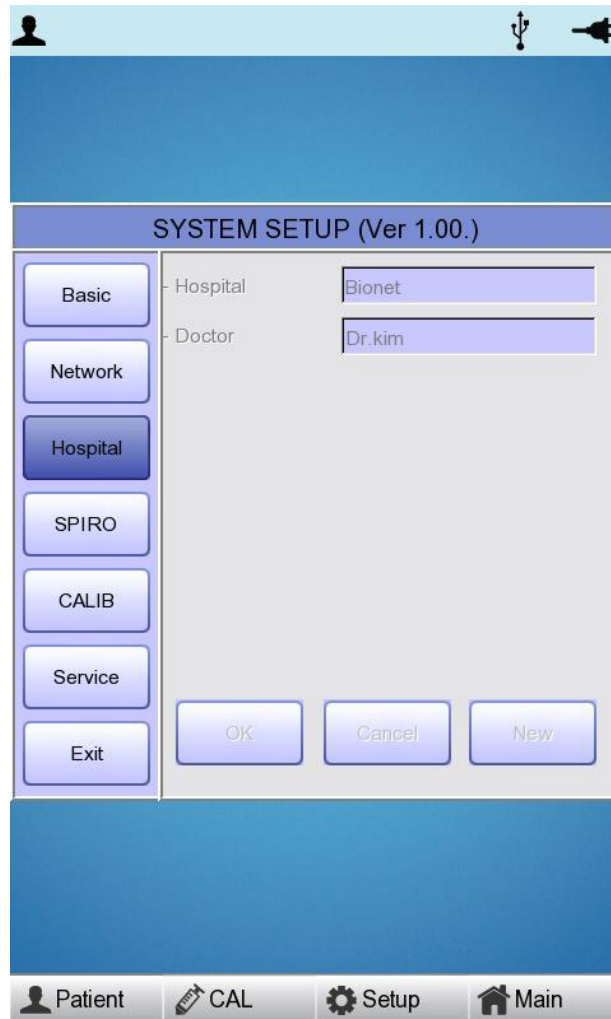

## SPIRO Setup

When selecting the 'SPIRO' menu at the left side of the Setup page, Spiro Setup page will show up at the right side.

### Formula

The 'Formula' is the diagnosis standard when executing a FVC test, therefore, after selecting the 'Formula', it is required to select one menu among 'Morris', 'Knudson', 'ECCS', 'Korea CJK' or 'Pereira'.

In addition, the contents of each Formula is explained as the below.

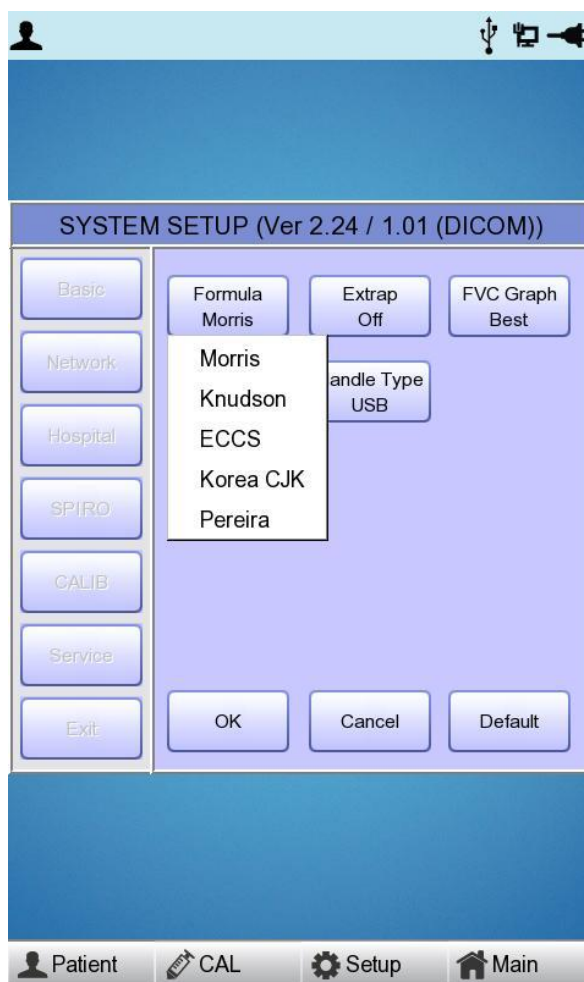

Ethnicity	Formula	Area
North America	Morris/Polgar	Prediction formula widely used in North America (Basic setup)
	Knudson/ITS	Prediction formula used worldwide
EU and Central and South America	ECCS/Quanjer	Prediction formula widely used in the EU
	Pereira	Prediction formula widely used in Central and South America
South Korea	Korea CJK	Prediction formula developed according to Korean characteristics

## Extrapolation

The 'Extrapolation' function decides if the extrapolated volume is printed in the FVC test. You are able to select ON/OFF by using the touch or rotary key.



1-second forced vital capacity is calculated at the point of 1 second from the start. If blowing with a slightly weak force at the initial point and then blowing hard, spirometry calculates 1-second forced vital capacity at the point 1 second from the start of weak blowing. However, it should in fact calculate at the point 1 second from the start of hard blowing. This amount of difference is called extrapolational difference.

The valid value scope of the extrapolated volume is 0.15L or within 15% of the FVC.

## Set the 'FVC' graph format

'FVC Graph' is used to set the 'FVC' graph format. If it will be set up as 'All', all graphs of three times test are printed. And if it will be set up as 'BEST', the best one graph of three times test are printed.

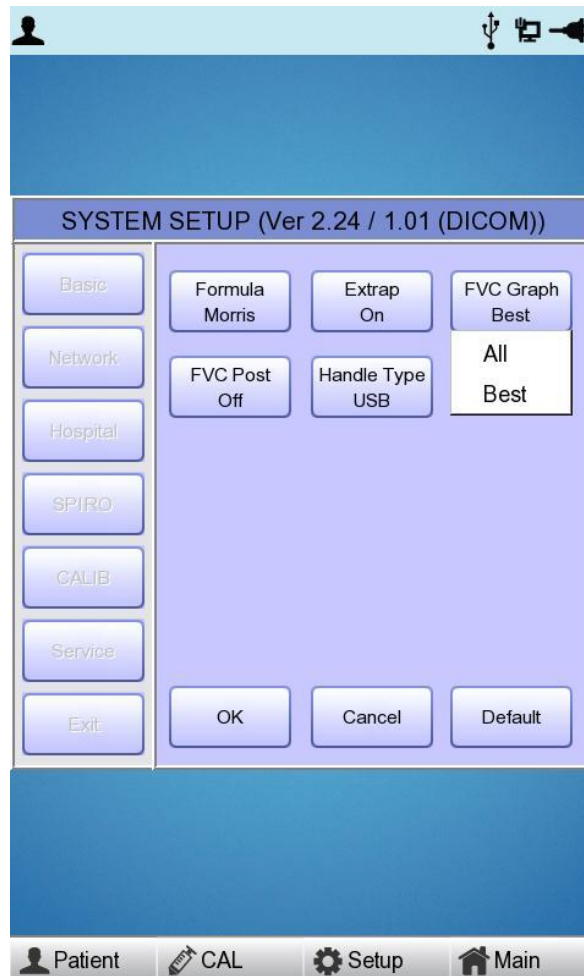

### Note

- In case of doing an 'FVC POST' test, even if 'FVC Graph' is set up as 'All', the best one graph of three times test are printed.

# SpiroCare Operation Manual

## The settings for the Post inspection

In case of the FVC inspection, all details of the drug test could be set. If it is set up as ON, the post inspection will be executed and if it is set up as OFF, the post inspection is not going to be executed.

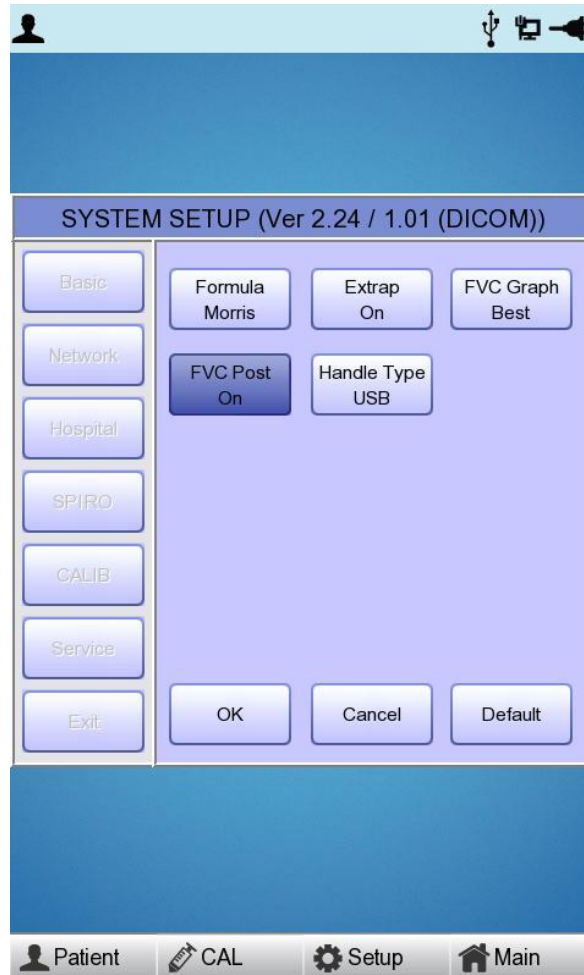

### Note

- Please select the patient of the FVC data in the File for the Post inspection and execute the 'Main' → 'Spiro' menu.

# SpiroCare Operation Manual

## Spirometer handle type

Set type of the Spirometer handle (USB or Serial). SpiroCare only connects to this type of Spirometer handle.

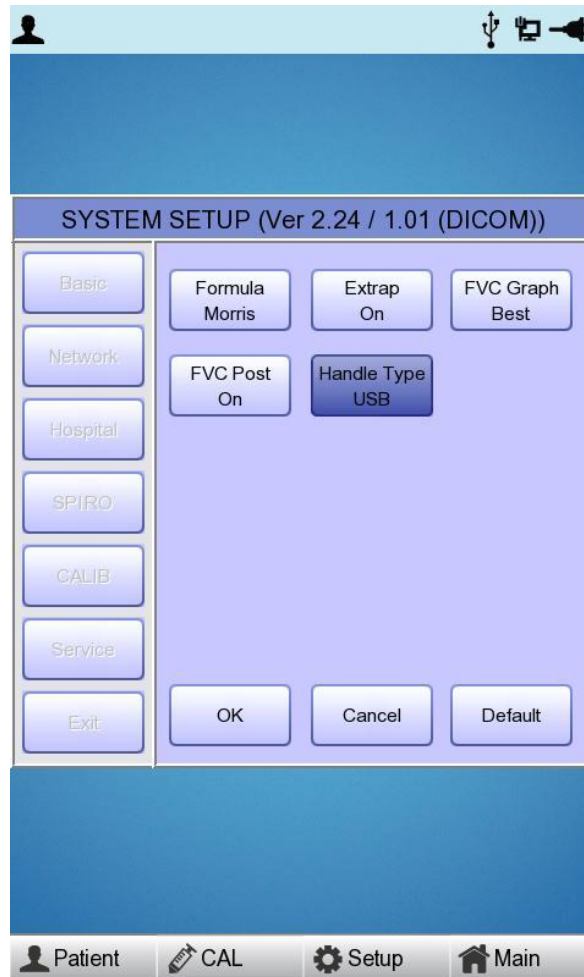

## Calibration Setup

When selecting the 'CALIB' menu at the left side of the Setup page, Calibration Setup page will show up at the right side.

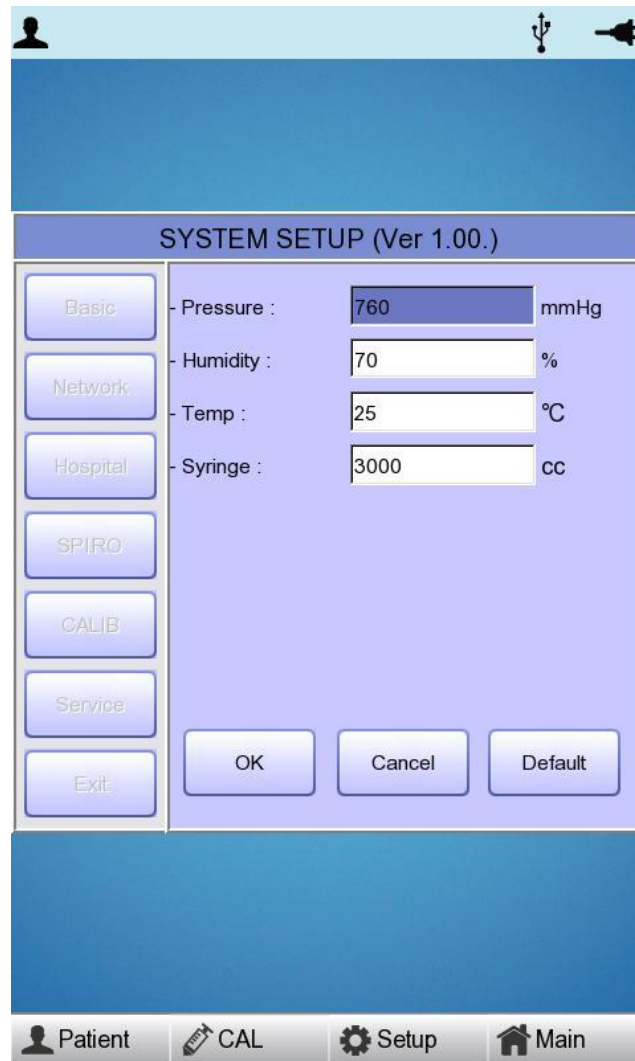

When selecting items such as Pressure, Humidity, Temperature and Syringe Size by using Rotary switch or tabbing, the number keypad input window will appear. When entering the appropriate value for each item in the Keypad input window, Calibration defaults are modified.

## Service Setup

If 'Service' menu on the left of the Setup screen is selected, the other Setup screen related to 'User Security Set' and 'Manufacturer Set' will appear.

At 'User Security Set' setup, it is possible to change Factory Setting and User Password.

At 'Manufacturer Set' setup, it is possible to change Upgrade and Device Options; please contact the Bionet Service Center.

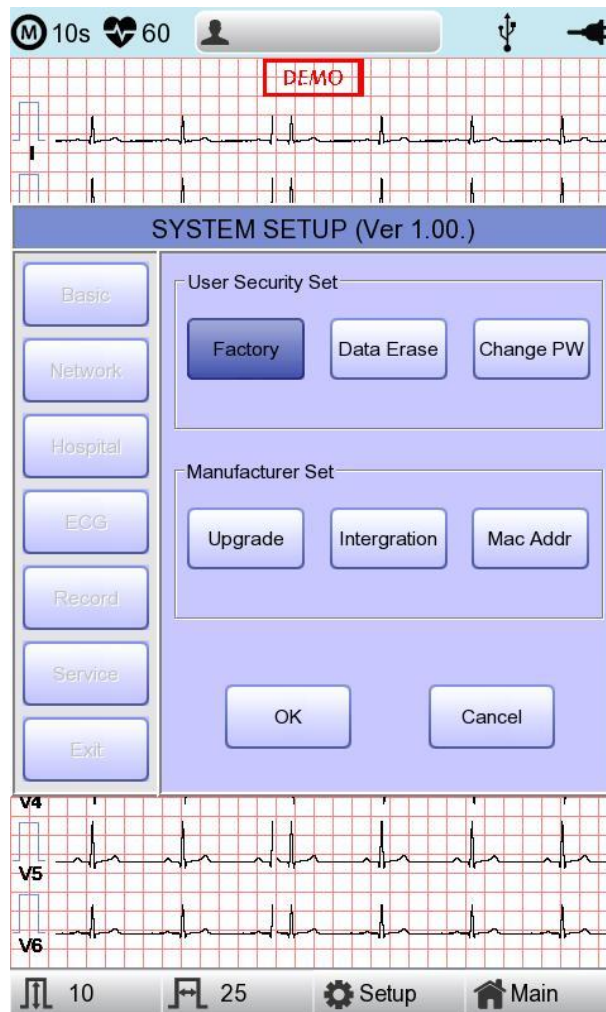

# SpiroCare Operation Manual

## Factory(Reset Settings)

In order to reset to factory conditions, press the 'Factory' button and enter the Password. Reset will proceed, with the message below appearing on the LCD screen for 1 second.

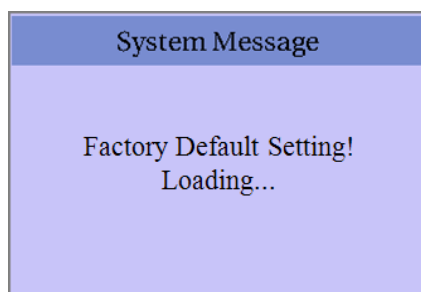

The initialized values are as follows.

Contents	Setting Value
Gain	10mm/mV
Speed	25mm/s
Start Option	Main
Unit	Height : cm, Weight : kg
Date Type	YYYY-MM-DD
Patient Info (File)	Delete
Device Name	SpiroCare
Net Device	Wired
Configure	Manually
Device IP	192.168.30.224
Subnet Mask	255.255.255.0
Gate way	192.168.30.1
BMS Server	0.0.0.0
Hospital	blank
Doctor	blank
Preview	On
Quick Print	Off
Lead Fault	On
Pacemaker	Off
QRS sound	Off
Demo	Off
Mon Form	12ch
Mon Size	Continue

# SpiroCare Operation Manual

Grid	Off
Rec Form	3ch + 3
Paper Size	A4
Print Line	Normal
Beat Form	Off
Rhythm	II, V1, V5
Base Filter	On
AC Filter	For ENG and KOR language, '60Hz' For other languages, '50Hz'
Low Pass Filter	150Hz
EMG Filter	Off
ECG Store	Yes
Print Out	Yes
Export	None
Diagnosis	Professional
ST Level	Auto
V Channel	None
Long Time	Off
Arrhythmia	Off
HRV	Off
Target	PC
Method	Manual
Format	EKG
Delete	Yes
JPEG Size	1024 x 768
Pressure	760mmHg
Humidity	70%
Temp	25°C
Syringe	3000cc
Patient information	initialized

## NOTE

Even though the system is reset, the 'User password' is not initialized.

## Data Erase

All data in Files and Worklist will be deleted.

For the data erasure function, a password must be entered

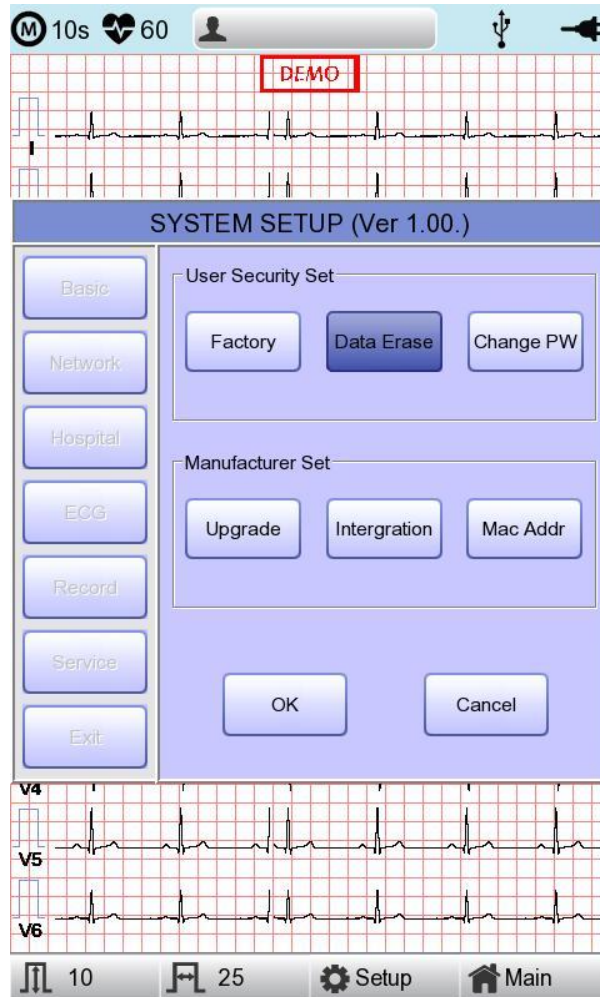

## Change PW

User Password can be configured. User Password is the number entered for Factory and Data Erase. The password should be a 4-digit number.

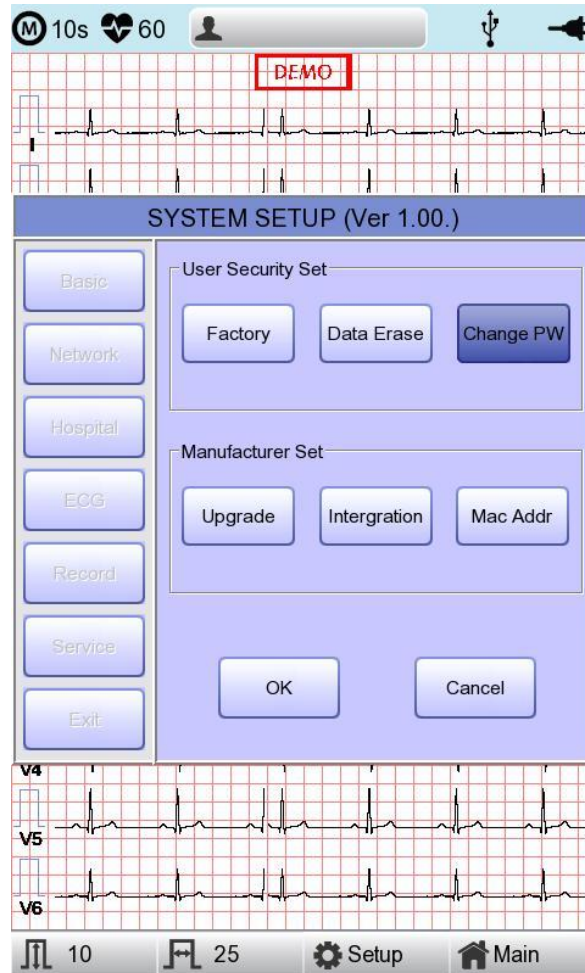

### NOTE

The default User Password is '1234'. If you forget the password, enter '1234' and reset.

## **Chapter 4. Spiro file management**

- 1) Display and function**
- 2) Data printing**
- 3) Data deleting**
- 4) System Setup**
- 5) Switching menu**
- 6) Patient information**
- 7) Data Search**
- 8) Data transfer**
- 9) Data import**

## 1) Display and function

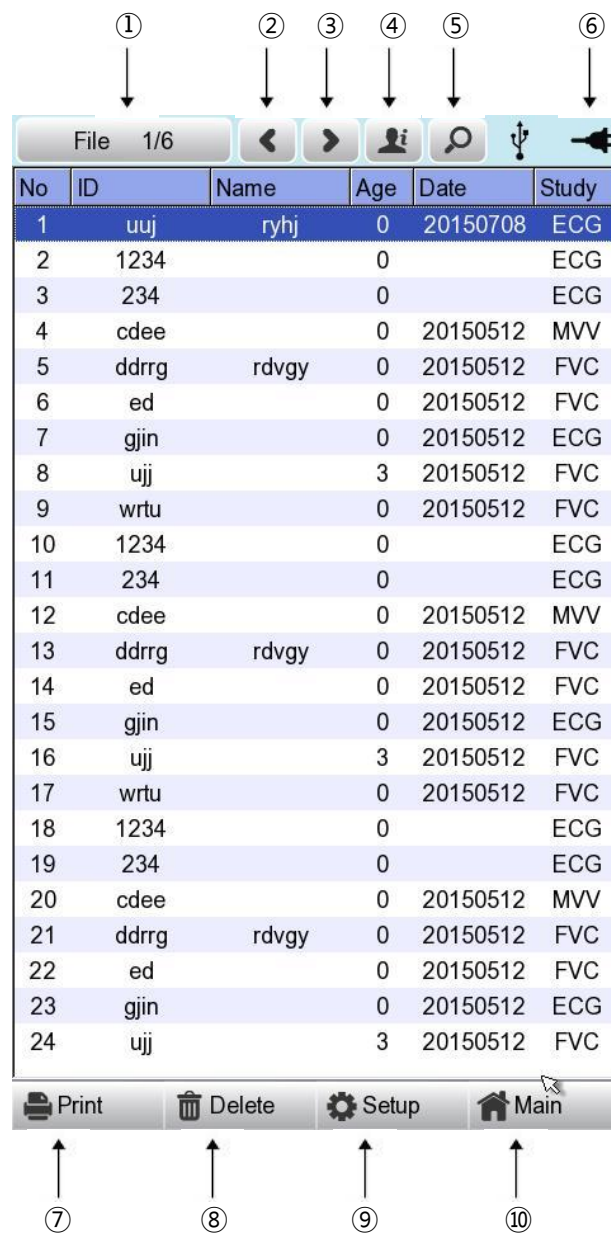

- ① Page information  
- For example, [1/20] means that you see the first page among total 20 pages. 1 Page contains 24 lines of Data.  
If Rotary is selected, the focus will be moved to Data list.
- ② Button to skip to the previous page
- ③ Button to skip to the next page
- ④ Button to check the patient's information of the chosen data saved
- ⑤ Button to search the data you want
- ⑥ State of battery or AC power connection

- ⑦ Button to print out the chosen saved data
- ⑧ Button to delete the data
- ⑨ Button to set up the environment of 'File Management'
- ⑩ Button to move to other main screen from 'File Management'

At the initial file management page, the first data of the list has the focus. The focus will automatically move to the menu bar at the bottom of the screen, when you click the data by touching the screen or rotating the rotary key on the control panel.

If there is no data in the page, the focus can be found on [Print] button.

When there is no patient information you want to select, please press [<] or [>] button or the 'Search' menu to move to other pages.

- Menu direction (Rotary Key's right spin)  
Print → Delete → Setup → Main → Page information → [<] → [>] → Info → Search → Print
- Menu direction (Rotary Key's left spin)  
Print → Search → Info → [>] → [<] → Page information → Main → Setup → Delete → Print

## 2) Data printing

When selecting a saved data at the ECG file management page by using rotary key or touch screen, the focus will appear at the data list.

Press the 'Print' button to print out the data. Then you will see a message as shown below.

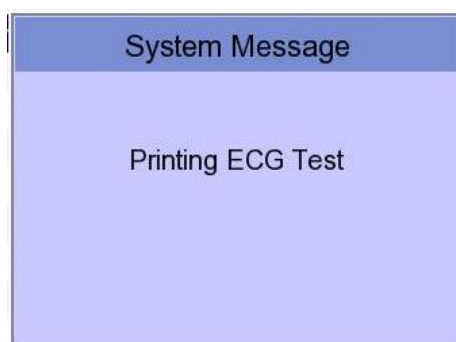

### Note

You should avoid attaching and detaching a USB device while printing out, as it could cause the printer module to rattle.

## 3) Data deleting

When pressing the 'Delete' button, a small pop-up menu will show up. You can choose to press the 'select' or 'all' button.

When you press the 'Select' button, one data record will be deleted, but if you press the 'All' button, all data in the list will be deleted.

In order to help the user not to make a mistake when deleting the data, a message shown as below will appear to reaffirm whether you really want to delete the data.



### Caution

Please think carefully before selecting the 'All' button, as it will permanently delete all of the Spiro data.

## 4) System Setup

When clicking the 'Setup' button at the ECG data file management page, you will see a 'System Setup' window as shown below.

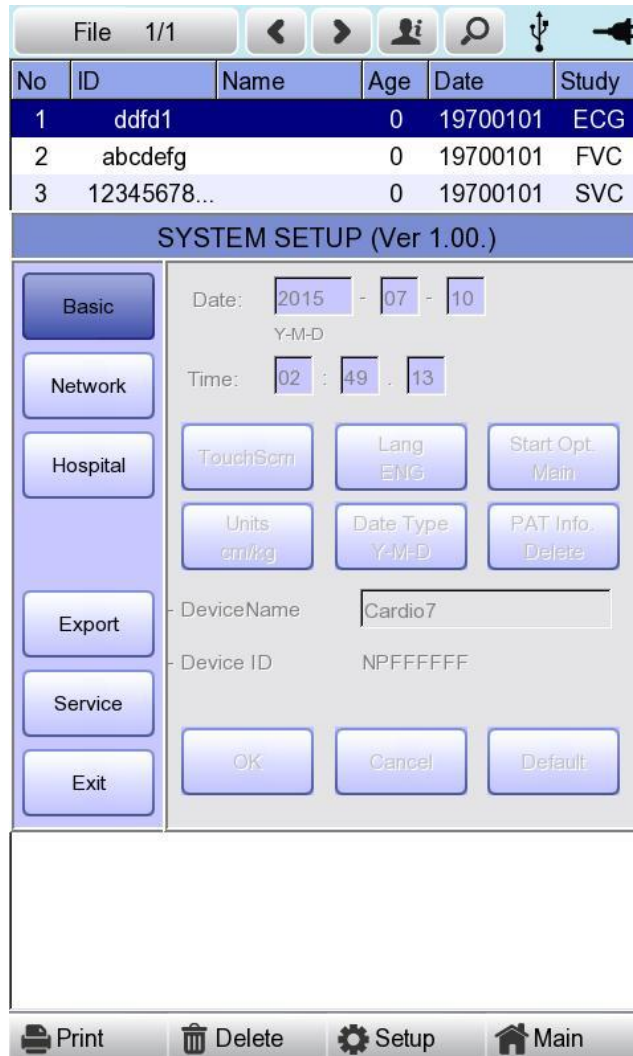

'PAT Info.' menu is to set up whether the patient information is retained or not, when you move the main screen of the Spiro. When you click the menu, 'Retain' will be set up and when clicking the menu again, 'Delete' will be set up. Default is set as 'Delete'.

- 'Delete': To set up the patient information is deleted, when you move to main screen of the Spiro.
- 'Retain': To set up the patient information is retained, when you move to main screen of the Spiro. This may result in more than one record for the same patient.

**Note**

The steps for Network, Hospital and Service Setting are identical with the steps for Spiro Main setting.

# SpiroCare Operation Manual

When clicking the 'Export' button, you will see 'Export' window as shown below.

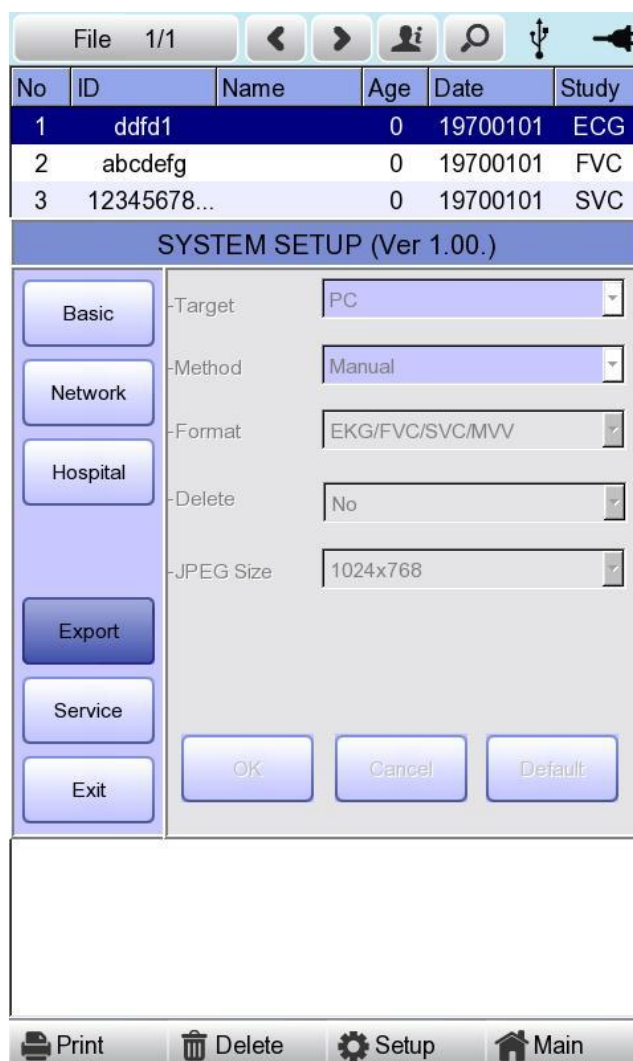

When clicking the 'Target' button, a POP-UP window will show up and it will disappear when selecting one of PC or USB.

- PC: To save the data in the PC connected with the equipment
- USB: To save the data in the external USB Memory

When clicking the 'Method' button, a small line window will show up and it will disappear when selecting Manual, Select, All or All New.

- Manual : menu window allows user to select either 'Selected, All, All New, Cancel' or 'Selected, Cancel' whenever transferring data
- Select : To transfer the selected data
- All : To transfer all data
- All New : To transfer the newly saved data

When clicking the 'Format' button, a line window will show up and it will disappear when selecting EKG/FVC/SVC/MVV, MFER(ECG), XML(ECG), JPEG, PDF. 'Format' menu is used to select the user's options when transferring the data.

- EKG/FVC/SVC/MVV: To save the data by type of '\*\*\*.ekg' / '\*\*\*.fvc' / '\*\*\*.svc' / '\*\*\*.mvv'
- MFER: To save the data by type of '\*\*\*.mwf'
- XML: To save the data by type of '\*\*\*.xml'
- JPEG: To save the data by type of '\*\*\*.jpg'
- PDF: To save the data by type of '\*\*\*.pdf'

When clicking the 'Delete' button, a line window will show up and it will disappear when selecting Yes or No. 'Delete' menu is used to select the user's options after the data has transferred.

- Yes: To delete the data after it has transferred
- No: To not delete the data after it has transferred

## NOTE

If 'Format' menu has only 'EKG/FVC/SVC/MVV' options, it is possible to select 'All' or 'All New' in 'Method' menu; for other formats, 'Selected' is the only option.

## 5) Switching menu

When selecting the 'Main' button at the main page of 'File management', a line window will show up. You can choose ECG, Spiro or Worklist to go to the chosen page.

The patient's information of selected data does not transmit when skipping to 'Worklist Management' screen. But it depends on the setting value of 'PAT Info.' menu when skipping to 'Spiro' main screen.

- ECG : skip to ECG main screen
- Worklist : skip to 'Worklist Management' screen
- Spiro : skip to spirometry measurement screen

## 6) Patient information

When selecting a saved data at the Spiro file management page by using a rotary key or a touch screen, the focus will appear at the data list.

Press the 'Info' button. Then you will see a 'Patient Information' window as shown below. Information other than patient name cannot be changed.

The screenshot displays the SpiroCare software interface. At the top, there is a navigation bar with icons for back, forward, info, search, USB, and power. Below this is a table with columns: No, ID, Name, Age, Date, and Study. The second row is highlighted in blue, indicating it is selected. A 'Patient Information' dialog box is overlaid on the table, containing the following fields:

No	ID	Name	Age	Date	Study
1	ddfd1		0	19700101	ECG
2	abcdefg		0	19700101	FVC
3	10015070		0	10700101	ECG

**Patient Information**

- \* ID:
- Name:
- \* Age:  years
- \* Gender:
- \* Height:  cm
- \* Weight:  kg
- \* Race:
- \* Smoke:
- Department:
- Room No:

Buttons: OK, Cancel

Bottom navigation bar: Print, Delete, Setup, Main

## 7) Data search

When clicking the 'Search' button at the Spiro data file management page, you will see a 'Patient Search' window as shown below. If you rotate the rotary key, the 'search condition' button will have focus. Press the 'Find' button after inputting the information about ID, Name, Date or Age.

When the search takes a long time, a message will show up to let you know the progress. After searching, you will see a data search result page.

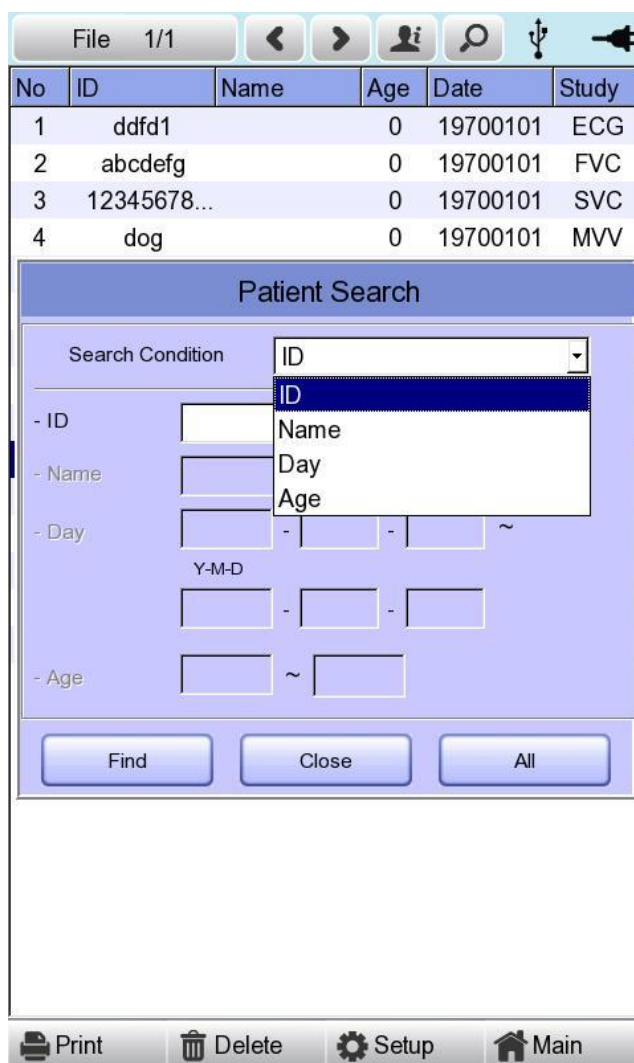

## 8) Data transfer

You can transfer the saved data to the external device at the Spiro data file management page by using the 'NETWORK' key on the control panel.

When pressing the 'NETWORK' key, a message will show up, asking which menu you want to select.



If you transfer a selected data record, a message with progress speed or other information will be shown as below.

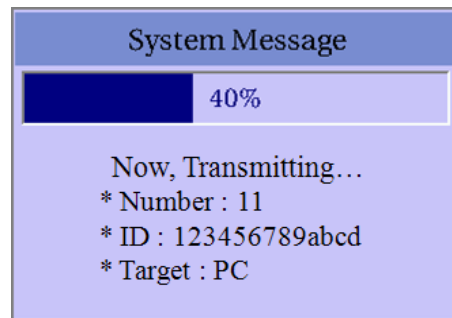

If you transfer all of the data, a message with progress speed or other information will be shown as below. In this case, the total number of files and the file being transferred currently will be displayed.

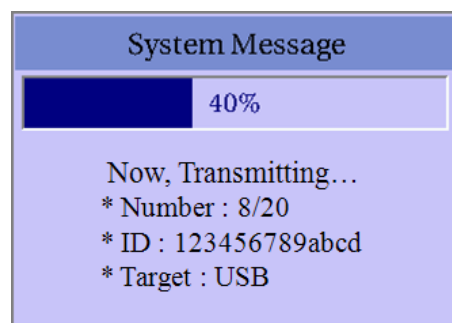

# SpiroCare Operation Manual

## NOTE

When transmitting multiple sets of data to PC after saving, a network error could occur which may cause transmission halt and subsequent loss of data. Therefore, it is recommended to transfer files immediately rather than aggregate a set of saved files.

## NOTE

If the system boots up without having LAN cable connected, the network function may not work properly. In this case, enter [System] -> [Network] -> [OK] then press 'NETWORK' button to attempt running the network function again. Please refer Network Setup part of the manual to get more information regarding IP configuration setup.

## 9) Data import

You can import the saved data from the external device at the Spiro data file management page by using the 'RECORD' key on the control panel.

When pressing the 'RECORD' key, 'Import File List' screen will be shown as below.

The screenshot displays the 'Import File List' screen. At the top, there is a header bar with 'File 1/1' and navigation icons. Below this is a table with columns: No, ID, Name, Age, Date, and Study. The table contains five rows of data. Below the table is a 'FILE LIST MANAGEMENT' dialog box with a table of file names and a 'No' column. The dialog box has 'Select', 'All', and 'Close' buttons. At the bottom of the screen, there are icons for 'Print', 'Delete', 'Setup', and 'Main'.

No	ID	Name	Age	Date	Study
1	ddfd1		0	19700101	ECG
2	abcdefg		0	19700101	FVC
3	12345678...		0	19700101	SVC
4	dog		0	19700101	MVV
5	abcdefg		0	20000101	MVV

No	Name
1	1234567890_19700101002436.SVC
2	111_20140101002029.MVV
3	7hh_20150101053631.MVV
4	abcdefg_19700101000101.FVC
5	abcdefg_20000101001909.MVV
6	abcdefg_20150101011837.MVV
7	ddfd1_19700101000750.ekg
8	111_20140101002029.MVV

# SpiroCare Operation Manual

If 2 different USB memory devices are connected, a system message window prompting you to select one of them will appear.

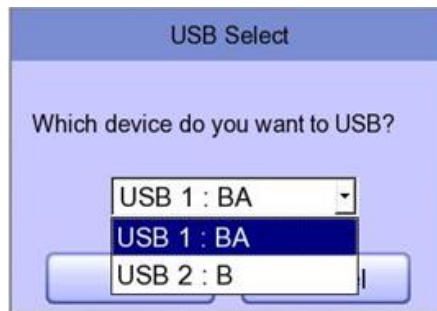

If the external device is not connected to SpiroCare, the error message will be shown as below.



If you select the 'Selected' menu in the 'Import File List' screen, after receiving the selected data from the external device a system message will be shown as below.



# SpiroCare Operation Manual

If you select the 'All' menu in the 'Import File List' screen, a system message with progress speed will be shown as below.

After receiving all data from the external device, a system message will be shown as below.

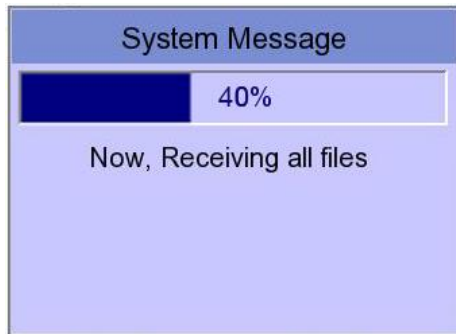

## **Chapter 5. Spiro worklist management**

- 1) Display and function**
- 2) Spiro Test**
- 3) Data deleting**
- 4) System Setup**
- 5) Switching menu**
- 6) Patient information**
- 7) Data search**

## 1) Display and function

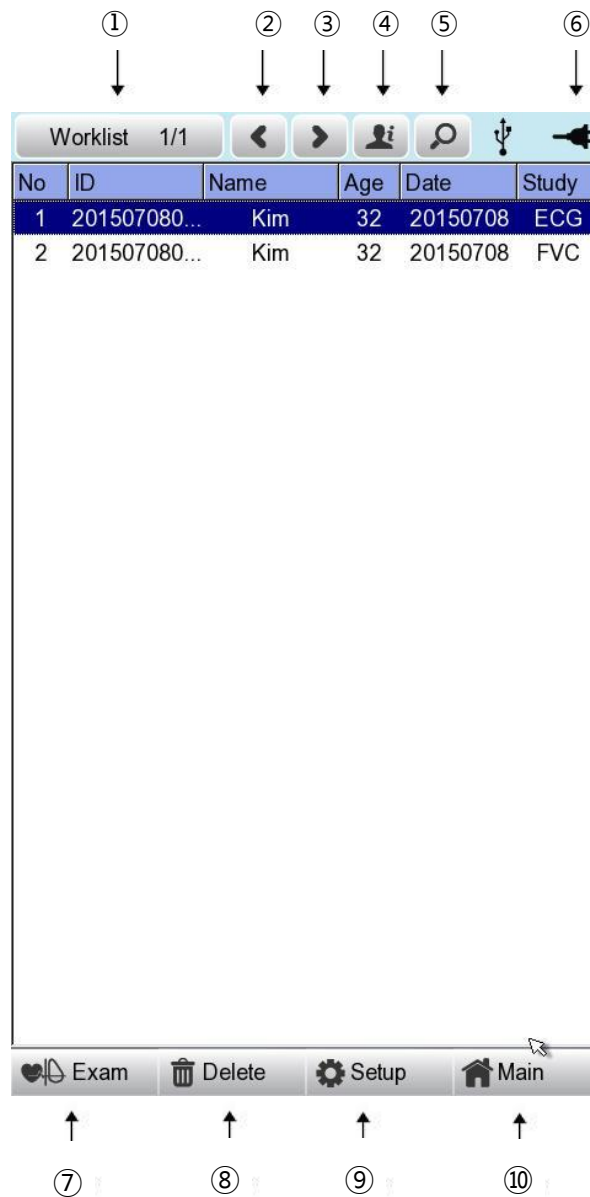

- ① Page information
  - For example, [1/20] means that you see the first page among total 20 pages.
  - 1 Page contains 24 Data.
  - If Rotary is selected, the focus will be moved to Data list.
- ② Button to skip to the previous page
- ③ Button to skip to the next page
- ④ Button to check the patient's information of the chosen data saved
- ⑤ Button to search the data you want
- ⑥ State of battery or AC power connection

- ⑦ Go to test window for the requested choice of data
- ⑧ Button to delete the data
- ⑨ Button to set up the environment of 'Worklist Management'
- ⑩ Button to move to other main screen from 'Worklist Management'

At the initial file management page, the first data of the list has the focus. The focus will automatically move to the menu bar at the bottom of the screen, when you click the data by touching the screen or rotating the rotary key on the control panel.

If there is no data in the page, the focus can be found on [Exam] button.

When there is no patient information you want to select, please press [<] or [>] button or the 'Search' menu to move to other pages.

- Menu direction (Rotary Key's right spin)

Exam → Delete → Setup → Main → Page information → [<] → [>] → Info → Search → Exam

- Menu direction (Rotary Key's left spin)

Exam → Search → Info → [>] → [<] → Page information → Main → Setup → Delete → Exam

## 2) Spiro Test

Select 'Exam' button to go to Spiro main screen in order to start spiro measurement with patient information in the test-requested data list.

There is no need to input additional information, as all of the patient information is already saved upon spiro test.

## 3) Data deleting

When pressing the 'Delete' button, a small pop-up menu will show up. You can choose to press the 'select' or 'all' button.

When you press the 'Select' button, one data will be deleted, but if you press the 'All' button, every data in the list will be deleted.

In order to help the user not to make a mistake when deleting the data, a message shown as below will appear to reaffirm whether you really want to delete the data.



### Caution

Please think carefully before selecting the 'All' button, as it will permanently delete all of the ECG data.

## 4) System Setup

When clicking the 'Setup' button at the Spiro data worklist management page, you will see the 'worklist System Setup' window as shown below.

Worklist 1/1

No	ID	Name	Age	Date	Study
----	----	------	-----	------	-------

**SYSTEM SETUP (Ver 1.00.)**

Basic

Network

Hospital

Service

Exit

Date: 2015 - 07 - 10  
Y-M-D

Time: 03 : 09 : 24

TouchScrn

Lang  
ENG

Start Opt  
Main

Units  
cm/kg

Date Type  
Y-M-D

DeviceName  
Cardio7

Device ID  
NPFFFFFF

OK Cancel Default

Exam Delete Setup Main

### Note

The steps for Network, Hospital and Service Setting are identical with the steps for Spiro Main setting.

## 5) Switching menu

When selecting the Main button at the main page of the Spiro file management, a line window will show up. You can choose ECG or FILE to go to the chosen page.

The patient's information of selected data does not transmit, when moving to other main screen.

- ECG: skip to ECG main screen
- FILE: skip to 'File Management' screen
- Spiro: skip to spirometry measurement screen

## 6) Patient information

When selecting saved data at the ECG file management page by using rotary key or touch screen, the focus will appear at the data list.

Press the 'Info' button to see the 'Patient Information' page. After checking all of the information, press the OK button and then the 'Patient Information' page will disappear.

No	ID	Name	Age	Date	Study
1	4567	dfgh	23		

**Patient Information**

\* ID: 4567

Name: dfgh

\* Age: 23 years

\* Gender: Female

\* Height: 155 cm

\* Weight: 55 kg

\* Race: White

Smoke: No

Department: \_\_\_\_\_

Room No: \_\_\_\_\_

Study Desc.: \_\_\_\_\_

Accession No.: \_\_\_\_\_

Ref. Physician: \_\_\_\_\_

OK

Exam Delete Setup Main

## 7) Data search

When clicking the 'Search' button at the Spiro data order management page, you will see a 'Patient Search' window as shown below. If you rotate the rotary key, the 'search condition' button will have focus.

Press the 'Find' button after inputting the information about ID, Name, Date or Age.

When the search takes a long time, a message will show up to let you know the progress. After searching, you will see a data search result page.

No	ID	Name	Age	Date	Study
1	4567	dfgh	23	20151123	FVC
2	4567	dfgh	23	20151123	SVC
3	4567	dfgh	23	20151123	MVV
4	1234	fghj	45	20151123	FVC

**Patient Search**

Search Condition: ID

- ID:

- Name:

- Day:  -  -  ~

Y-M-D

-  -

- Age:  ~

Exam Delete Setup Main

## **Chapter 6. System Management**

- 1) Maintenance and Cleaning**
- 2) Regular Check-up**
- 3) Trouble Shooting**
- 4) Manufacturer Declaration**

## 1) Maintenance and Cleaning

There are many ways to clean SpiroCare, but it is best to use our recommendation to avoid damage or sanitary issues.

The warranty does not cover problems resulting from the use of harmful substances (unauthorized substances).

### Caution

After cleaning the product, check the hardware and the electrodes.  
Do not use the product if it is damaged or worn.

- Rub the product with gauze damp with alcohol about once a month to clean the product as well as the electrodes. Do not use lacquer, thinner, ethylene or oxide.
- Do not submerge the product or the ECG cable into any liquid or detergent. Also make sure there is no liquid in the product or the cable.

### Disposal of your old appliance

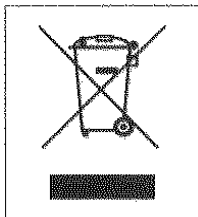

1. When this crossed out wheeled bin symbol is attached to a product it means the product is covered by the European Directive 2002/96/EC.
2. All electrical and electronic products should be disposed of separately from the municipal waste stream via designated collection facilities appointed by the government or the local authorities.
3. The correct disposal of your old appliance will help prevent potential negative consequences for the environment and human health.
4. For more detailed information about disposal of your old appliance, please contact your city office, waste disposal service or the shop where you purchased the product.

### WARNING

This product contains a chemical known to the State of California to cause cancer, birth defects, or other reproductive harm.

## 2) Regular Check-up

Like every other medical product, SpiroCare requires a regular check-up once a year. Please refer to the service manual for the information on the check-up.

## 3) Trouble Shooting

- **Printing was not successful:**  
The cover may not be closed properly. Please close the cover and print again.
- **When using the battery power, there was a beep for more than 3 times and a message came as shown below:**

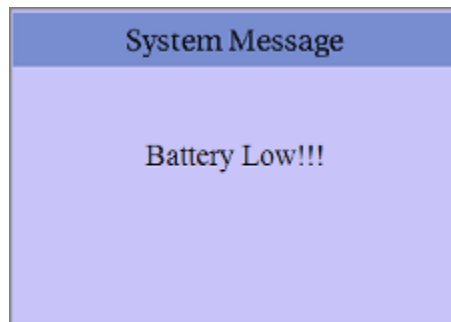

The battery is low. Please connect to the AC power to use.

- **Flickering screen when turning on the device**  
This indicates that the battery is running low, and therefore it will disappear when the device is turned on again after connecting AC power.

\* If it is still not working, please contact our customer service center.

# SpiroCare Operation Manual

## ● System messages

The following system messages may occur while you are operating this system. You may be required to perform some action. If you perform the recommended actions and the condition still remains, contact authorized service personnel.

No.	System message	Cause	Solution
1	Please check date and time	Internal coin battery is discharged.	Please contact CS (Customer Support) team of Bionet to replace old coin type battery with new one
2	Address is not valid	When wrong network address(IP, SM, GW) is entered	Check the right network address before input
3	Invalid value. [Use: 0~9, A~F]	When wrong character is entered at time of inputting Mac address	Please input valid character such as 0~9, A to F in number and alphabet respectively
4	There is no patient ID. Please enter patient ID.	When you implement AUTO or NET button without patient ID	Please enter patient ID in patient information window to implement
5	Wrong password. Please re-enter your password.	When wrong password is entered	Check and input right password
6	Enter password length error. Please re-enter your password	When wrong number of characters is entered as password	Please check and input valid and correct password
7	The internal memory is full. Please erase other files or transfer to external storage.	When over 200 files are stored at internal memory	Erase files in File menu
8	Not enough free disk space	USB memory device has insufficient space to receive files.	Remove unnecessary files from USB memory (Minimum 500KB space is needed to export 1 file)
9	Please check the USB memory.	When USB memory stick is not inserted, or is out of order	Please check and insert USB memory stick in right position. Note that USB memory file format supports FAT, FAT32 only (this can be checked on PC)

## SpiroCare Operation Manual

10	There is no Access Point. Please check the AP	There is no wireless access point detected.	Check AP and retry
11	Fail, connecting. Do you want to retry?	When wireless AP connection is failed	- Press Retry button - Retry after checking AP
12	Ping : Failed	When there is connecting failure between network and PC with BMS Server	- Check System setup and network - Check PC network setup - Check LAN cable or wireless environment
13	Verify : C-Echo Failed	When there is failure between PACS Server PC and network	- Check system setup and network - Check PC network setup - Check LAN cable or wireless environment - Please check PACS programs are working
14	IP address conflict.	The devices IP address is already in use on the network	Please contact 'Network Team' to check IP address, and set right IP in turn of System setup and Network
15	Connection Error. Check lan cable, network setting and relevant program.	When there is failure of network connection	Please check LAN cable connection, network setting, server PC's networking and related S/W programs
16	File Trans Fail!!	When file transmission to server PC or USB memory fails	Check server PC's networking conditions, and USB memory, and retry
17	Check Worklist Server IP	When server IP of PACS worklist is not input	Input server IP of PACS worklist in turn of System setup, Network and PACS setting
18	Check Device AE Title	When AE Title of device is not input	Input AE title of device in turn of System setup, Network and PACS setting
19	Check Device Port	When port of device is not input	Input port of device in turn of System setup, Network and PACS setting
20	Check Worklist Server Port	When server port of PACS Worklist server is not input	Input server port of PACS Worklist server in turn of System setup, Network and PACS setting
21	Check Store AE Title	AE title of PACS store server is not input	Input AE title of PACS store server in turn of System setup, Network and PACS setting

## SpiroCare Operation Manual

22	Fail to send Image	When file transmission to PACS store server has failed	Retry after checking network conditions
23	Fail to connect Store Server	When there is Connection failure between PACS store server and device	Check network condition with PACS store server
24	Transmission failed file is existing. Are you sure to delete?	When the transmission failed file to PACS store server needs to be deleted	Delete the failed file after transmitting the file to PACS store server
25	Recharge Battery!	When the battery level is Low	Please connect power cable or charge battery
26	Printer: Time out.	Printer stops working due to technical problem of device	Check the printer
27	Printer: Busy continue	When the wrong printer data were input	Check the printer
28	Printer: Temperature high	When the Printer gets heated due to long and continuous use of printer	Please stop the use of printer for at least one minute and try again
29	Printer: Paper empty	When the printing paper is completely out	Please put new roll of printing paper for use
30	Printer: Printer not ready	When there is no 'ready' answer from printer module	Check the printer
31	Printer: Unknown data	When the wrong protocol was put into the printer	Check the printer
32	Abnormal End!	When the printer was abnormally forced to stop during printing	Re-start printing
33	Please check handle!	<ul style="list-style-type: none"> <li>- When the Spirometer handle is not connected</li> <li>- When the spirometer handle is disconnected during test</li> </ul>	Check the Spirometer handle is connected
34	Correction factor(s) outside of acceptable range of 0.8~1.2	When the factor value is out of tolerance range during the calibration	Repeat the calibration until the calibrated values are within the tolerance range
35	Please repeat the calibration until the calibrated value reaches the tolerance range 3% (2.91~3.09L)!	When the difference values are out of tolerance range during the calibration	Repeat the calibration until the calibrated values are within the tolerance range

# SpiroCare Operation Manual

36	Fail : Time out!!	- When the calibration time is exceeded - When the FVC test time is exceeded	Redo the calibration Redo the FVC test
37	The breath protocol Failed!	When the test protocol goes wrong	Re-test with right test protocol of FVC, SVC and MVV
38	Examination Zeroing Fail!	When the zeroing of spirometer handle is failed	Redo the test
39	Examination Start Fail!	When initialization is failed	Redo the test after initialization
40	Fill patient information	When necessary patient information is not input	Fill all necessary information(*) in patient information window, and retry the test

## 4) Manufacturer Declaration

### Electromagnetic Compatibility Information

Phenomenon	Basic EMC standard or test method	Test level/requirement
Mains terminal disturbance voltage	CISPR 11	Group 1, Class A
Radiated disturbance	CISPR 11	Group 1, Class A
Harmonic Current Emission	IEC 61000-3-2	Class A
Voltage change, Voltage fluctuations and Flicker Emission	IEC 61000-3-3	Pst: 1 Plt: 0.65 Tmax: 0.5 dmax: 4% dc: 3.3%
Electrostatic Discharge Immunity	IEC 61000-4-2	± 8 kV/Contact  ± 2, ± 4, ± 8, ± 15 kV/Air
Radiated RF Electromagnetic Field Immunity	IEC 61000-4-3	3 V/m 80 MHz - 2.7 GHz 80% AM at 1 kHz
Immunity to Proximity Fields from RF wireless Communications Equipment	IEC 61000-4-3	Table 9 in IEC 60601-1-2: 2014
Electrical Fast Transient/Burst Immunity	IEC 61000-4-4	± 2 kV, 100 kHz repetition frequency  ± 1 kV, 100 kHz repetition frequency

# SpiroCare Operation Manual

Surge Immunity	IEC 61000-4-5	Line to Line ± 0.5 kV, ± 1 kV  Line to Ground ± 0.5 kV, ± 1 kV, ± 2 kV
Immunity to Conducted Disturbances Induced by RF fields	IEC 61000-4-6	3 V 0.15 MHz - 80 MHz  6 V in ISM bands Between 0.15 MHz and 80 MHz  80% AM at 1 kHz
Power Frequency Magnetic Field Immunity	IEC 61000-4-8	30 A/m 50 Hz and 60 Hz
Voltage dips	IEC 61000-4-11	0 % $U_T$ ; 0.5 cycle At 0°, 45°, 90°, 135°, 180°, 225°, 270° and 315°  0 % $U_T$ ; 1 cycle and 70 % $U_T$ ; 25/30 cycles Single phase: at 0°
Voltage interruptions	IEC 61000-4-11	0 % $U_T$ ; 250/300 cycle

## Electromagnetic compatibility\_ Guidance and manufacturer's declaration

Guidance and manufacturer's declaration – electromagnetic emissions		
The SpiroCare is intended for use in the electromagnetic environment specified below. The customer or the user of the SpiroCare should assure that it is used in such an environment.		
Emissions test	Compliance	Electromagnetic environment - guidance
RF emissions CISPR 11	Group 1	The SpiroCare uses RF energy only for its internal function. Therefore, its RF emissions are very low and are not likely to cause any interference in nearby electronic equipment.
RF emissions CISPR 11	Class A	The SpiroCare is suitable for use in all establishments other than domestic, and may be used in domestic establishments and those directly connected to the public low-voltage power supply network that supplies buildings used for domestic
Harmonic emissions IEC 61000-3-2	Class A	

# SpiroCare Operation Manual

Voltage fluctuations/ flicker emissions IEC 61000-3-3	Complies	purposes, provided the following warning is heeded:  <b>Warning:</b> This equipment/system is intended for use by healthcare professionals only. This equipment/ system may cause radio interference or may disrupt the operation of nearby equipment. It may be necessary to take mitigation measures, such as re-orienting or relocating the SpiroCare or shielding the location.
---	----------	---

# SpiroCare Operation Manual

<b>Guidance and manufacturer's declaration – electromagnetic immunity</b>			
The SpiroCare is intended for use in the electromagnetic environment specified below. The customer or the user of the SpiroCare should assure that it is used in such an environment.			
<b>IMMUNITY test</b>	<b>IEC 60601 test level</b>	<b>Compliance level</b>	<b>Electromagnetic environment - guidance</b>
Electrostatic discharge (ESD) IEC 61000-4-2	± 6 kV contact  ± 8 kV air	± 6 kV contact  ± 8 kV air	Floors should be wood, concrete or ceramic tile. If floors are covered with synthetic material, the relative humidity should be at least 30 %.
Electrical fast transient/burst IEC 61000-4-4	± 2 kV for power supply lines  ± 1 kV for input/output lines	± 2 kV for power supply lines  ± 1 kV for input/output lines	Mains power quality should be that of a typical commercial or hospital environment.
Surge IEC 61000-4-5	± 1 kV line(s) to line(s)  ± 2 kV line(s) to earth	± 1 kV line(s) to line(s)  ± 2 kV line(s) to earth	Mains power quality should be that of a typical commercial or hospital environment.
Voltage dips, short interruptions and voltage variations on power supply input lines IEC 61000-4-11	<5%UT (>95%dip in UT) for 0,5 cycle 40 %UT (60 %dip in UT) for 5, 6 cycles 70 %UT (30 %dip in UT) for 25,30 cycles <5%UT (>95%dip in UT) for 5 s	<5%UT (>95%dip in UT) for 0,5 cycle 40 %UT (60 %dip in UT) for 5, 6 cycles 70 %UT (30 %dip in UT) for 25,30 cycles <5%UT (>95%dip in UT) for 5 s	Mains power quality should be that of a typical commercial or hospital environment. If the user of the SpiroCare requires continued operation during power mains interruptions, it is recommended that the SpiroCare be powered from an uninterruptible power supply or a battery.
Power frequency (50/60 Hz) magnetic field IEC 61000-4-	3 A/m	3 A/m	Power frequency magnetic fields should be at levels characteristic of a typical location in a typical commercial or hospital environment.
NOTE $U_T$ is the a.c. mains voltage prior to application of the test level.			

# SpiroCare Operation Manual

<b>Guidance and manufacturer's declaration – electromagnetic immunity</b>			
The SpiroCare is intended for use in the electromagnetic environment specified below. The customer or the user of the SpiroCare should assure that it is used in such an environment.			
IMMUNITY test	IEC 60601 test level	Compliance level	Electromagnetic environment - guidance
Conducted RF IEC 61000-4-6	3 Vrms 150 kHz to 80 MHz	3 V rms	<p>Portable and mobile RF communications equipment should be used no closer to any part of the SpiroCare, including cables, than the recommended separation distance calculated from the equation applicable to the frequency of the transmitter.</p> <p><b>Recommended separation distance</b></p> $d = \left[ \frac{3,5}{V_1} \right] \sqrt{P}$
Radiated RF IEC 61000-4-3	3 V/m 80 MHz to 2,5 GHz	3 V/m	<p><math>d = \left[ \frac{3,5}{E_1} \right] \sqrt{P}</math>      80 MHz to 800 MHz</p> <p><math>d = \left[ \frac{7}{E_1} \right] \sqrt{P}</math>      800 MHz to 2,5 GHz</p> <p>where <math>P</math> is the maximum output power rating of the transmitter in watts (W) according to the transmitter manufacturer and <math>d</math> is the recommended separation distance in meters (m).</p> <p>Field strengths from fixed RF transmitters, as determined by an electromagnetic site survey,<sup>a</sup> should be less than the compliance level in each frequency range.<sup>b</sup></p> <p>Interference may occur in the vicinity of equipment marked with the following symbol:</p> <div style="text-align: center;">  </div>
NOTE 1 At 80 MHz and 800 MHz, the higher frequency range applies.			
NOTE 2 These guidelines may not apply in all situations. Electromagnetic propagation is affected by absorption and reflection from structures, objects and people.			

# SpiroCare Operation Manual

- <sup>a</sup> Field strengths from fixed transmitters, such as base stations for radio (cellular/cordless) telephones and land mobile radios, amateur radio, AM and FM radio broadcast and TV broadcast cannot be predicted theoretically with accuracy. To assess the electromagnetic environment due to fixed RF transmitters, an electromagnetic site survey should be considered. If the measured field strength in the location in which the SpiroCare is used exceeds the applicable RF compliance level above, the SpiroCare should be observed to verify normal operation. If abnormal performance is observed, additional measures may be necessary, such as re-orienting or relocating the SpiroCare.
- <sup>b</sup> Over the frequency range 150 kHz to 80 MHz, field strength should be less than 3 V/m

## Recommended separation distances between portable and mobile RF communications equipment and the SpiroCare

The SpiroCare is intended for use in an electromagnetic environment in which radiated RF disturbances are controlled. The customer or the user of the SpiroCare can help prevent electromagnetic interference by maintaining a minimum distance between portable and mobile RF communications equipment (transmitters) and the SpiroCare as recommended below, according to the maximum output power of the communications equipment.

Rated maximum output power of transmitter [W]	Separation distance according to frequency of transmitter [m]		
	150 kHz to 80 MHz	80 MHz to 800 MHz	800 MHz to 2,5 GHz
	$d = \left[\frac{3,5}{V_1}\right]\sqrt{P}$	$d = \left[\frac{3,5}{E_1}\right]\sqrt{P}$	$d = \left[\frac{7}{E_1}\right]\sqrt{P}$
	V1= 3 Vrms	E1= 3 V/m	E1= 3 V/m
0.01	0.12	0.12	0.23
0.1	0.37	0.37	0.74
1	1.17	1.17	2.33
10	3.69	3.69	7.38
100	11.67	11.67	23.33

For transmitters rated at a maximum output power not listed above, the recommended separation distance  $d$  in meters (m) can be estimated using the equation applicable to the frequency of the transmitter, where  $P$  is the maximum output power rating of the transmitter in watts (W) according to the transmitter manufacturer.

NOTE 1 At 80 MHz and 800 MHz, the separation distance for the higher frequency range applies.

NOTE 2 These guidelines may not apply in all situations. Electromagnetic propagation is affected by absorption and reflection from structures, objects and people.

## Chapter 7. Specification

<b>Dimension</b>	47(W) x 200(H) x 34(D)mm, approx. 250g
<b>Measuring values</b>	FVC: FVC, FEV1, FEV1/FVC, FEF 0.2-1.2L, FEF 25-75%, FEF 75-85%, PEF, FEF 25%, FEF 50%, FEF 75%, FIVC, FEV6, PEFT, FET 100%, FVL Error Code SVC: SVC, TV, ERV, IRV, EC MVV: MVV, FB, TV
<b>Presentation</b>	Flow Volume loop Volume Time Graph Measurement values table
<b>Measuring range</b>	Flow: 0 to $\pm 14$ l/s Volume: 0 to $\pm 12$ l
<b>Measuring method</b>	Differential pressure method
<b>Prediction equation</b>	Morris-Polgar, Knudson-ITS, ECCS-Quanjer, Korea CJK, Pereira
<b>Sample rate</b>	200 samples/sec
<b>Flow impedance</b>	< 0.2 mbar s/l at 12 l/s
<b>Measuring accuracy</b>	Complies with ATS(American Thoracic Society)
<b>Data storage</b>	Storage for 200 data (Internal on flash memory)
<b>Display</b>	800 x 480 pixel resolution, 7" Color TFT wide display
<b>User Interface</b>	Touch screen(Alphanumeric and symbol available)
<b>Printer Resolution</b>	Thermal print head, Roll Paper Report paper - width : A4/Letter 215mm(8.5") - length : A4 297 mm (11.7") Letter 279mm(11") - Resolution: 8dot/mm(0.125mm pitch)
<b>Line Power</b>	Input:100 - 240 V~ 2-1A, 50/60Hz , Output : 15VDC , 4A 60VA
<b>Battery type</b>	Replaceable and rechargeable, Lithium ion , 11.1V , 2600mA
<b>Battery Capacity</b>	360 minutes of continuous operation without recording or 200 ECGs in 12 channel format at 25mm/s and 10mm/mV with a battery charged during approximately 3 hours from total discharge(with display off)
<b>Communication</b>	LAN, WIFI(option), USB flash memory, USB barcode scanner
<b>Safety Conformity</b>	Class I, Type CF
<b>Environment</b>	Operating temperature: 5 ~ 40°C Operating humidity: 10~90% RH Atmospheric pressure: 70 ~ 106KPa
<b>Standard accessory</b>	Disposable mouthpiece (2 EA), Nose clip (1 EA), Handle dock (1EA),

# SpiroCare Operation Manual

	User Manual & Diagnosis Guide (1 EA)
<b>Optional accessory</b>	Battery (1 EA), PFT Filter (100 EA), Disposable mouthpiece 1 box (100 EA), Calibration Syringe[3L] (1 EA), Cart(1EA)

## WARRANTY

Product Name	Spirometer
Model Name	SpiroCare
License Number	
License Date	
Serial Number	
Warranty period	3 year from date of purchase (2 years in Europe)
Date of purchase	(yyyy/mm/dd)
Customer	Hospital: Address: Name: Contact No:
Seller's Name	
Manufacturer's Name	

- ※ This product is a medical machine.
- ※ This product meets the strict quality requirements thoroughly.
- ※ The repairing and compensation standards follow the consumer damage compensation regulations of the Ministry of Finance and Economy.

# SpiroCare Operation Manual