

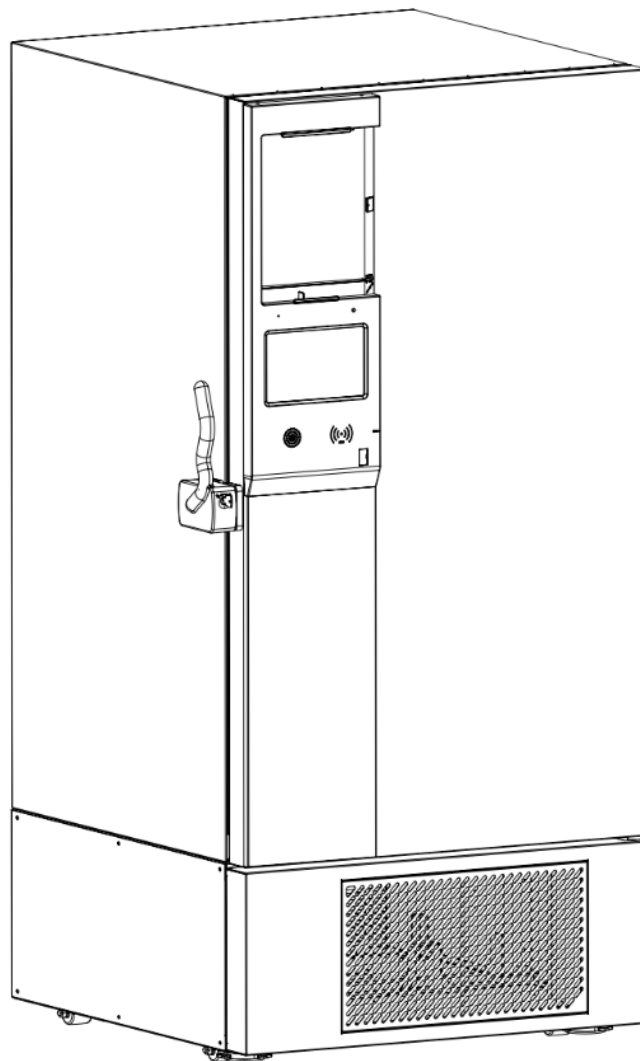

Dual Inverter Ultra Low Temperature Lab Freezer

Models: KM-PHF-20CUL, KM-PHF-25CUL, KM-PHF-30CUL

LAB FREEZER



Before using, please read the operating instructions carefully to ensure proper application and achieve satisfactory results.

Contents

Safety	5
Before Use	9
Installation	11
Parts	16
Operations	18
Maintenance	42
Specification	44
Packing List	45
Diagram	46
Troubleshooting	48
Warranty	49



WARNING: Flammable material.



WARNING: Low temperature/freezing conditions, frostbite HAZARD(MOD).



WARNING: Electrocution Hazard.



WARNING: Crushing of hands.



Frostbite Waring.



Warning.

CYCLOPENTANE

Cyclopentane Foam

Safety

Please carefully read the following information to better understand the Operating Instructions and use this product, so as to prevent personal injury and damage to items.

 **WARNING:** Flammable refrigerant is used in this product.

This unit is intended for use in commercial, industrial, or institutional occupancies as defined in the Safety Standard for Refrigeration Systems, ANSI/ASHRAE 15.

Parts Replacement and Servicing

These installation and operating instructions require that any component parts be replaced only with identical or approved equivalents, and that all servicing be performed by authorized personnel. This ensures proper operation and reduces the risk of ignition caused by incorrect parts or improper service.

WARNING: Ensure all ventilation openings are not obstructed.

WARNING: Do not use mechanical devices or other means to accelerate the defrosting process, other than those recommended by the manufacturer.

WARNING: Do not damage the refrigerant circuit.

WARNING: The packaging base at the bottom of the unit must be removed before use.

WARNING: When moving the unit, take care that the bottom foot does not touch the power cord.

WARNING: The bottom front wheel brake of the unit needs to be locked after moving to the designated position.

WARNING: Before using this unit for the first time, allow it to stand upright for at least 12 hours before plugging it in.

WARNING: After connecting the unit to the power supply, do not load items immediately. Allow the unit to run until the internal temperature reaches the set operating temperature, then add items gradually in batches.

Refrigerant and the cyclopentane foam insulation used in this unit are flammable. When disposing of the unit, keep it away from all ignition sources and ensure it is handled by a licensed recycling or recovery company. The unit must not be incinerated, as improper disposal can cause environmental harm or create safety risks.

The safety of any system that incorporates this equipment is the responsibility of the system's assembler.

IMPORTANT: It is the consumer's responsibility to comply with Federal and Local regulations when disposing of this product.

WARNING: To reduce the risk of fire or flammability hazards, installation of this unit must be performed only by a suitably qualified and authorized technician.

DANGER: Risk of Fire or Explosion. Flammable Refrigerant Used. To Be Repaired Only By Trained Service Personnel. Do Not Puncture Refrigerant Tubing.

CAUTION: Risk of Fire or Explosion. Flammable Refrigerant Used. Consult Repair Manual / Owner's Guide before attempting to install or Service This Equipment. All Safety Precautions Must be Followed.

WARNING: Using the equipment in any way not specified by the manufacturer may compromise its safety features and void the warranty.

Product Overview

Structure

Primarily consists of refrigeration system, electrical control and alarm system, cabinet, and door body.

Scope of Application

Applicable to the low-temperature storage of human examination samples, drugs, vaccines, biological products, reagents, plasma and other samples stored in medical institutions, blood stations, scientific research institutions and other departments under low temperature conditions.

Refrigeration System

Mainly composed of compressor, condenser, dryer filter, capillary tube, and evaporator.

Safety Precautions

WARNING:

Ignoring WARNING items may result in serious injury or death.

CAUTION:

Ignoring CAUTION items may result in minor injury or damage to the unit or surrounding property.

Prohibited Actions:

Acts or operations that must not be performed.

Required Actions:

Actions or operations that must be followed to ensure safe use.

CAUTION: Disposal Safety

- Dispose of the appliance in accordance with **federal and local regulations**.
- The appliance contains flammable refrigerant.

CAUTION: Handling Precautions

- Risk of fire or explosion if the refrigerant tubing is punctured.
- Follow handling instructions carefully.



- Do not store flammable, explosive, or volatile materials in the unit, and do not use flammable sprays near it. Doing so may result in fire or explosion.
- Do not store corrosive chemicals such as acids or alkalis inside the freezer. These substances can damage internal components and electrical parts.
- Keep plastic packaging bags out of the reach of children to prevent suffocation hazards.
- Do not climb on the unit or place heavy objects on top of it. The freezer may tip over and cause injury or property damage.
- Do not use this product outdoors. Exposure to rain can cause electrical shock or electrical leakage.
- Do not place the unit in areas with high humidity or where it may be splashed with water. Excess moisture can reduce insulation and lead to electrical shock.
- Do not pour water directly onto the freezer. This may cause electrical shock or a short circuit.
- Never attempt to disassemble, repair, or modify the unit on your own. Improper service can cause fire, electrical shock, or injury.
- Do not connect the grounding wire to gas pipes, water pipes, telephone lines, or lightning rods. Incorrect grounding may result in electrical shock or other hazards.
- Do not touch the power plug or operate switches with wet hands, as this can cause electrical shock.
- Do not place containers of liquid or heavy items on top of the unit. Spilled water can cause electrical leakage, and falling objects may cause injury.
- Never insert metal objects such as nails, wires, or tools into vents, gaps, or air outlets. This may result in injury or electric shock from contact with moving or live components.
- Do not drag, pull, twist, bind, or damage the power cord. A damaged cord or plug may cause fire or electric shock.
- Do not use the unit with a loose or damaged power plug, as this can cause fire or electrical shock.
- Do not store glass bottles or canned items in the freezer. They may freeze, crack, and cause injury.

 **CAUTION:**



- Keep the area around the unit clear to ensure proper airflow and ventilation.
- After a power outage or shutdown, verify that the temperature setpoint and settings are correct before restarting the freezer. Incorrect settings may damage stored materials.
- After the freezer is turned off or an outage, wait at least 5 minutes before turning the freezer back on to prevent compressor or system damage.
- Clean the air filter at least once per month. A dirty filter can cause temperature instability or system malfunction.
- If the power plug becomes dusty, clean it promptly. Dust buildup can cause poor connections, overheating, or even fire.
- Wear gloves during maintenance to avoid injury from sharp edges or corners.
- Do not touch stored items or interior surfaces with bare hands. Direct contact with frozen materials or inner walls may cause frostbite.
- Use the door handle when closing the door to prevent finger pinching.

- When moving or transporting the unit, do not tilt it more than 30° to avoid damaging internal components.



- During product handling, care should be taken not to trip over it to prevent damage to the product or personal injury.
- Do not use the door handle to lift or carry the product to avoid damage to it or personal injuries.
- Do not damage the refrigeration circuit.
- Do not use appliances inside the product except for those recommended by the manufacturer.

 **NOTICE! Risk of Damage:**

Vacuum insulation panels are used in the construction of these ULT freezers. Inspect the cabinet panels for punctures or other damage that compromises the integrity of the product

These panels are mounted in the cavity against the steel outer wall of the freezer. Any drilling or puncture to the outer wall could release the vacuum from the panel, resulting in impaired freezer performance.

Any unauthorized punctures or intentional damage to the cabinet walls will void the warranty.

WARNING: Dispose of the refrigerator in accordance with local regulations, as it contains flammable blowing agents and refrigerant.

Before Use

Usage Guidelines

- When the unit is running, the front area near the outer door may feel warm. This is normal and is caused by built-in anti-condensation components designed to prevent moisture buildup on the exterior surface.
- Before loading items, make sure the internal temperature has reached the setpoint. Add items in small batches, ensuring each load is no more than one-third of the compartment volume to avoid excessive temperature rise.
- The displayed temperature reflects the reading at the sensor location inside the cabinet. When the unit first starts, the displayed value may differ slightly from the internal center temperature. After the unit stabilizes, the displayed temperature will closely match the actual temperature.
- Some models include a test port for inserting temperature probes. After removing the probe or test lead, seal the test port with insulation material. Failure to do so may prevent the freezer from reaching the set temperature and can cause condensation around the port.
- Clean the unit using a diluted neutral cleaner. Do not use brushes, acids, gasoline, abrasive powders, polishing agents, or hot water, as these may damage painted, plastic, or rubber components. Never use volatile solvents (such as gasoline) on plastic or rubber parts.
- If the freezer will not be used for an extended period, disconnect the power and turn off the battery switch.
- Minimize the amount of time the door is open when loading or removing items to help maintain stable compartment temperature.
- After the door is opened, a brief temperature rise inside the compartment is normal. The temperature will return to the setpoint once the door is closed and the unit resumes normal operation.
- Over time, frost may form on the interior walls. If the frost layer reaches approximately 5 mm, defrost the unit using the provided plastic scraper. Excessive frost reduces cooling efficiency and increases energy consumption.
- Before defrosting, remove all stored items and place them in an environment that maintains their required storage temperature.
- Do not use sharp tools such as knives, chisels, or screwdrivers to remove frost. These can damage the refrigerant coils or inner liner, leading to product failure. Always avoid scratching the interior surfaces during defrosting.
- The enclosure can only be opened with tools, and repairs must be performed exclusively by qualified technicians or authorized after-sales service personnel. Unauthorized access or servicing may result in electric shock, fire, or serious injury.

Handling

1. Use proper equipment when moving the unit. Transport the product with a manual hydraulic pallet truck or similar appropriate lifting device to prevent damage.
2. Remove all packaging. Take off all packing materials, including the bottom cushion, before moving the unit into the building for placement.
3. Allow the unit to settle. After positioning the freezer in its final location, wait 24 hours before powering it on to ensure proper compressor oil return and stable operation.



Door Space Requirements

The unit's door must be able to open fully as shown.

$W \times D \geq 68.90 \text{ in} \times 76.77 \text{ in}$ (for KM-PHF-20CUL)

$W \times D \geq 65.75 \text{ in} \times 62.99 \text{ in}$ (for KM-PHF-25CUL)

$W \times D \geq 54.92 \text{ in} \times 59.06 \text{ in}$ (for KM-PHF-30CUL)

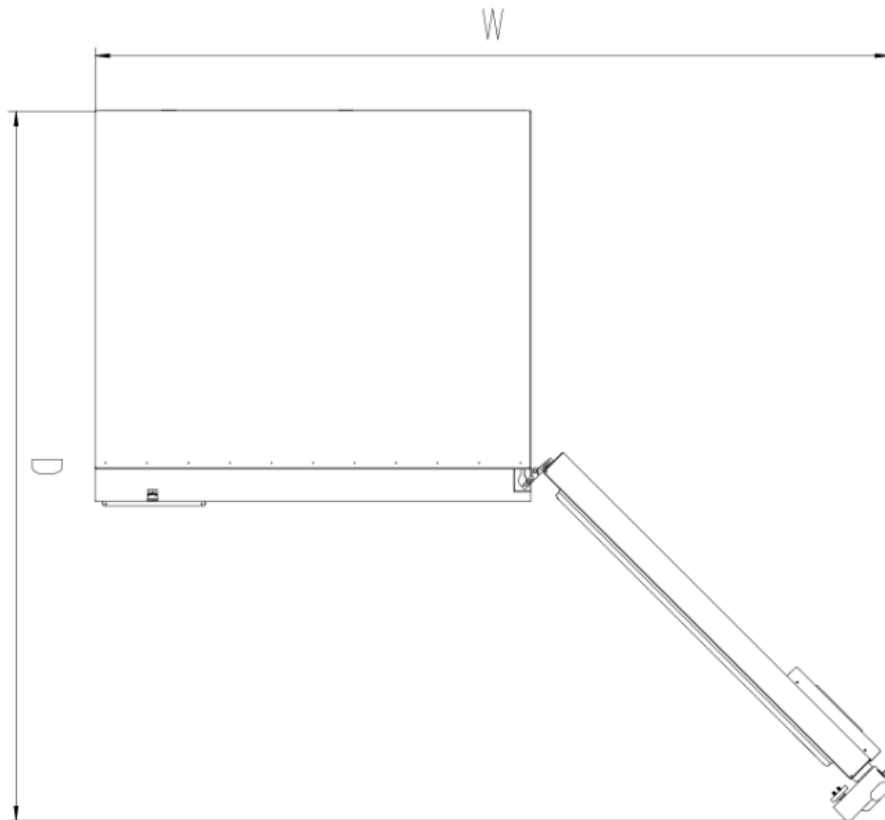

Installation

Installation Environment

- This product is designed for indoor use only and must not be installed outdoors.
- **Ambient Operating Temperature:** 10°C–32°C (50°F–89.6°F).
The optimal operating range is 18°C–25°C (64.4°F–77°F). Use air conditioning if needed to maintain this range.
- **Ambient Humidity:** Below 80% RH. At the maximum temperature of 32°C (89.6°F), humidity should be kept below 60% RH.
- **Pollution Degree:** Level 2. Avoid environments with excessive dust.
- **Power Supply Environment:** Overvoltage Category II.
- Avoid installing the unit in locations with mechanical vibration or movement.
- **Maximum Installation Altitude:** Below 2,000 m (6,562 ft).
- **Input Voltage:** AC 100–240V ±10%, 50/60 Hz.
- This product is sensitive to ambient conditions. If the environment does not meet the above requirements, the freezer may not operate normally. Improve the installation environment before use.
- Transportation and Storage Conditions:
 - **Ambient Temperature:** –40°C to +55°C (–40°F to 131°F)
 - **Humidity:** 10%–90% RH

Installation Site

- Do not install the unit in a confined or enclosed space. The doorway to the room where the biomedical freezer is installed must be large enough to allow normal access and removal of the equipment. Restricted access can make maintenance difficult and may result in damage to stored items if the unit cannot be serviced promptly in the event of a failure.
- The installation surface must be solid, level, non-combustible, and capable of supporting the full weight of the equipment during operation.
- Choose a location with good ventilation and no direct sunlight.
- Each unit must be connected to its own dedicated power outlet.
 - For 220V, the outlet must support 10A or more.
 - For 115V, the outlet must support 14A or more.Ensure the plug fits securely and firmly into the socket.
- Verify the working voltage before use.
In regions with unstable voltage, use a voltage stabilizer rated for the equipment's load and above 10 kW to ensure the input voltage remains within the required range.
- The equipment must be properly grounded.
If the power outlet includes a grounding terminal, ensure it is correctly connected.
If not, a qualified technician must install a proper grounding connection.

WARNING

- Do not connect the grounding wire to gas pipes, water pipes, telephone lines, or lightning rods. Improper grounding can result in electrical shock or serious hazards.
- The power plug must remain accessible after installation so it can be quickly unplugged in an emergency.
- Do not block the ventilation openings of the product.

CAUTION!

The ambient environment has a significant effect on the performance of this equipment. If the installation conditions do not meet the required specifications, the unit may not operate properly. Improve the surrounding environment before using the equipment.

Please also note that the unit operates on an intermittent refrigeration cycle, which is normal for this type of system.

Preparations Before Use

1. Remove all transport packaging materials and packaging straps (including protective foam in the packaging box).
2. Check the accompanying accessories. Please check the items inside with reference to the packing list. If there is any discrepancy, Please contact the company you purchased it from or KoolMore Customer Service promptly.
3. Placement conditions: Ensure at least 11.8 in. clearance around all sides of the product for proper ventilation and heat dissipation.

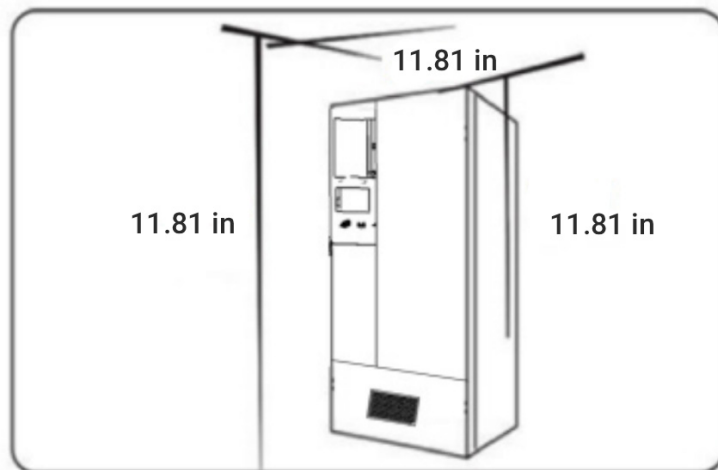

4. To remove the product from the wooden shipping base, first remove the 16 screws that secure the wooden support boards—eight screws on each side at the front and back. Once the screws are removed, gently push the freezer to one side so that the unit separates from the wooden support on that side. Slide the wooden support out and allow that side of the unit to lower carefully to the floor. Then repeat the process on the opposite side: push the unit slightly to separate it from the remaining wooden support, pull the support out, and lower the unit fully onto the ground. After both supports are removed, the product will be completely freed from the wooden base.

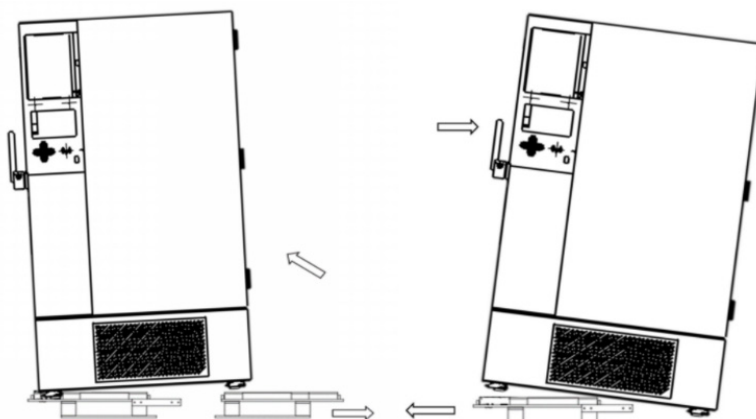

5. This product is equipped with universal wheels, allowing it to move forward, backward, left, and right for easy positioning. Once the unit is in the desired location, secure it by adjusting the leveling feet. Rotate the leveling feet upward or downward as needed to keep the product stable and properly leveled.

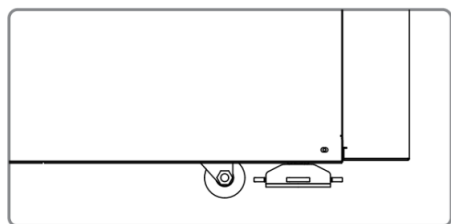
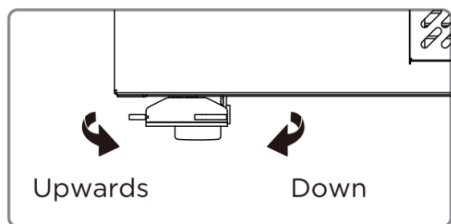

6. Open the outer door to more than 90°, remove the shelves from the bottom of the freezer, take off the protective film, and then place the shelves one by one onto the shelf support rails.

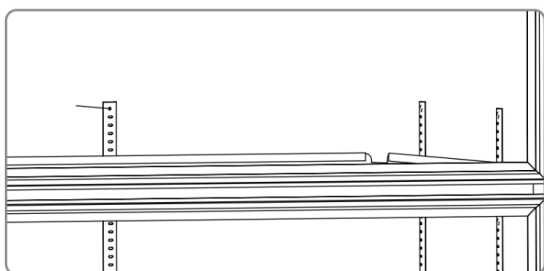

⚠ WARNING

Keep the plastic packing bag out of the reach of children to prevent the risk of suffocation.

7. Remove the back-spacing brackets from inside the cabinet and attach them to the rear of the unit using the provided screws. These brackets ensure proper clearance from the wall and prevent the freezer from being pushed too far back.

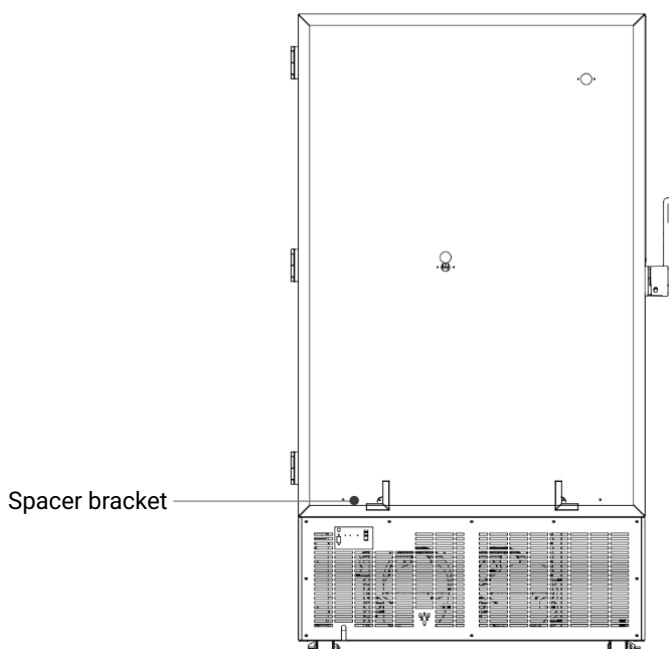

Initial Startup

When using the product for the first time, follow the steps below:

- After positioning, leveling, and cleaning the unit, allow it to stand for at least 24 hours before powering it on to ensure proper operation of the compressor.
- Connect the power cord to a dedicated outlet that meets the required electrical specifications, and ensure the unit is connected under no-load conditions (with nothing inside).
- After plugging in the unit, switch on the product's circuit breaker. If the model includes a backup battery, turn on the battery switch located at the lower rear of the unit. Once activated, the battery will begin charging automatically.
- Set the desired temperature (factory default is -81°C). Do not place any items inside at this stage. Allow the freezer to run and confirm that it can reach and maintain the set temperature. Observe the unit for at least 24 hours to ensure stable performance.
- After confirming stable operation, load items in batches, with each batch not exceeding one-third of the freezer's total volume. Ensure that the freezer can return to normal operating temperature for at least 8 hours before adding the next batch.
- Minimize door openings during the initial cooling cycle, as this will cause the internal temperature to rise.
- **Note:** Over-temperature alarms are disabled for the first 8 hours after the initial power-on.

Backup Battery

- This product is equipped with a backup battery. The battery switch is located on the lower left side of the rear panel.
- When the switch is turned ON, the unit will automatically charge the backup battery whenever the freezer is powered.
- When the switch is turned OFF, the battery will not charge even if the unit is powered.
- Once the battery is fully charged, charging stops automatically—no user action is required.

Frame Heating Function

This model includes a frame heating function, which automatically activates in response to changes in ambient humidity. Its purpose is to prevent condensation around the door frame and cabinet. No user operation is required.

After a Power Failure

The unit automatically remembers the temperature setpoint and all operating parameters. When power is restored, the freezer will resume operation using the same settings that were active before the power outage.

WARNING

- If the product is unplugged or the power to the biomedical freezer is interrupted, do not restart the biomedical freezer for at least 5 minutes to avoid damage to the compressor or system.
- When the product is going to be left unused for a long time, unplug the power plug and turn off the battery switch (applicable to products with batteries) to prevent electric shocks, electric leakages, or fire due to aging of the power cord.
- If the product is to be stored unused in an unsupervised area for a long period, ensure that children do not have access to the product and that doors cannot be closed completely.



- The unit should be monitored by a designated responsible person who checks the operation regularly and records the temperature and status at least once every 2–4 hours. In the event of a malfunction or shutdown, the internal temperature will rise. If the unit cannot be repaired promptly, transfer stored items immediately to another storage location that meets the required temperature conditions to prevent loss or damage.
- This product is an ultra-low temperature freezer. Always verify that the required storage temperature for your materials matches the freezer's temperature range to prevent damage or economic loss due to incorrect storage conditions.
- Because of normal refrigeration system behavior, the displayed temperature may differ slightly from the actual temperature inside the chamber. This is expected and does not indicate a malfunction.
- Do not load large quantities of warm items at once. Adding too many warm items can cause prolonged compressor operation, slow temperature recovery, and reduced compressor life. Always load items in small batches, allowing the temperature to drop until the required temperature is reached.
- Do not damage the refrigeration circuit under any circumstances.
- Do not place unauthorized or uncertified electrical devices inside the freezer.
- Do not use mechanical tools or unapproved methods to speed up the defrosting process. Only follow the manufacturer's approved defrosting procedures.

Parts

Schematic Diagram of Appearance

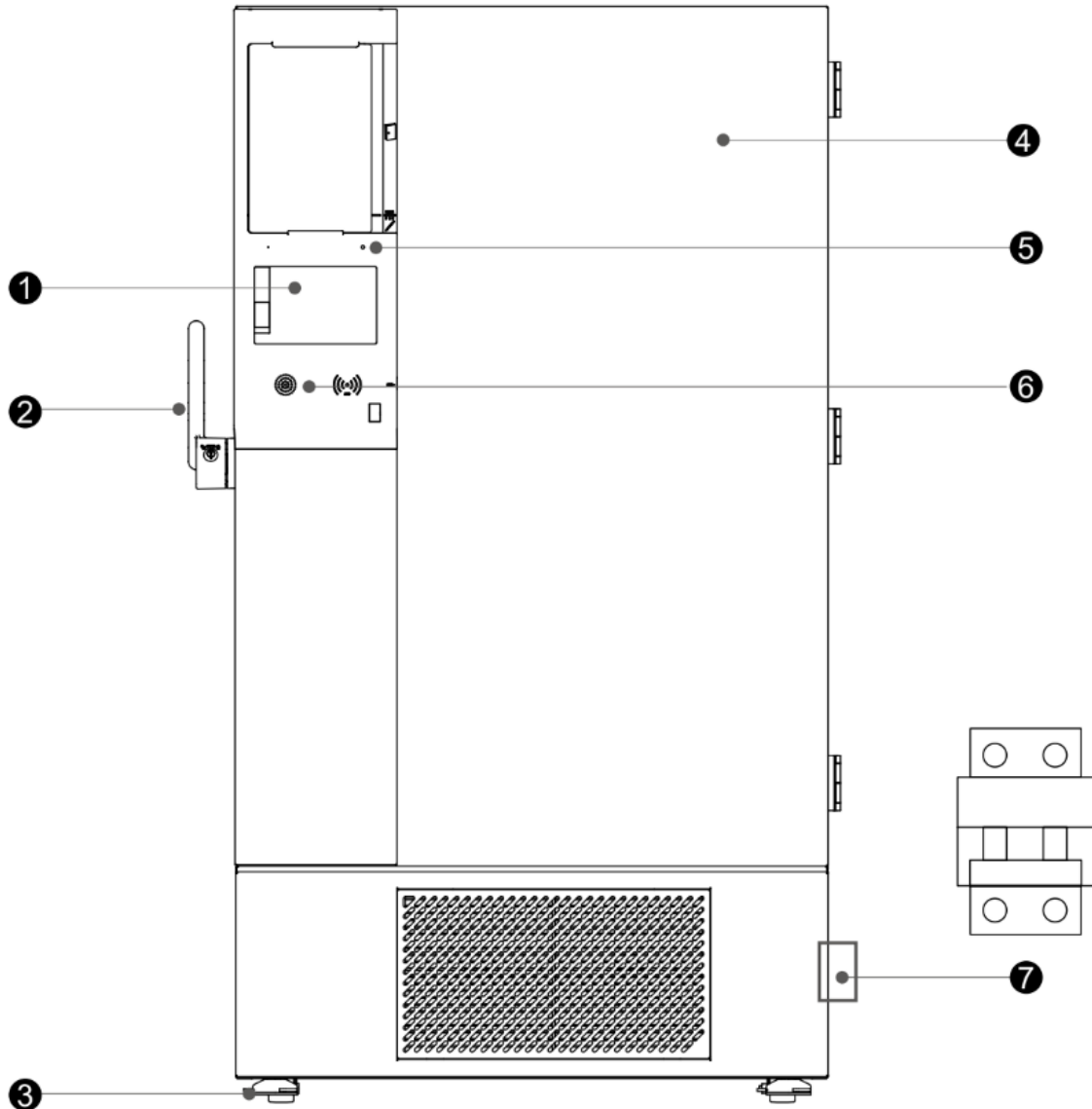

Schematic Diagram (front view and partial view)

- | | |
|----------------------|------------------------------|
| 1. Control Panel | 5. State Indicator |
| 2. Outer Door Handle | 6. Balance Valve |
| 3. Universal Wheel | 7. Miniature Circuit Breaker |
| 4. Door Assembly | |

Due to ongoing product improvements and variations between models, the actual product may differ slightly from the diagrams shown. Always refer to the actual unit for accurate details.

The diagrams are intended only as a general reference for identifying functional parts.

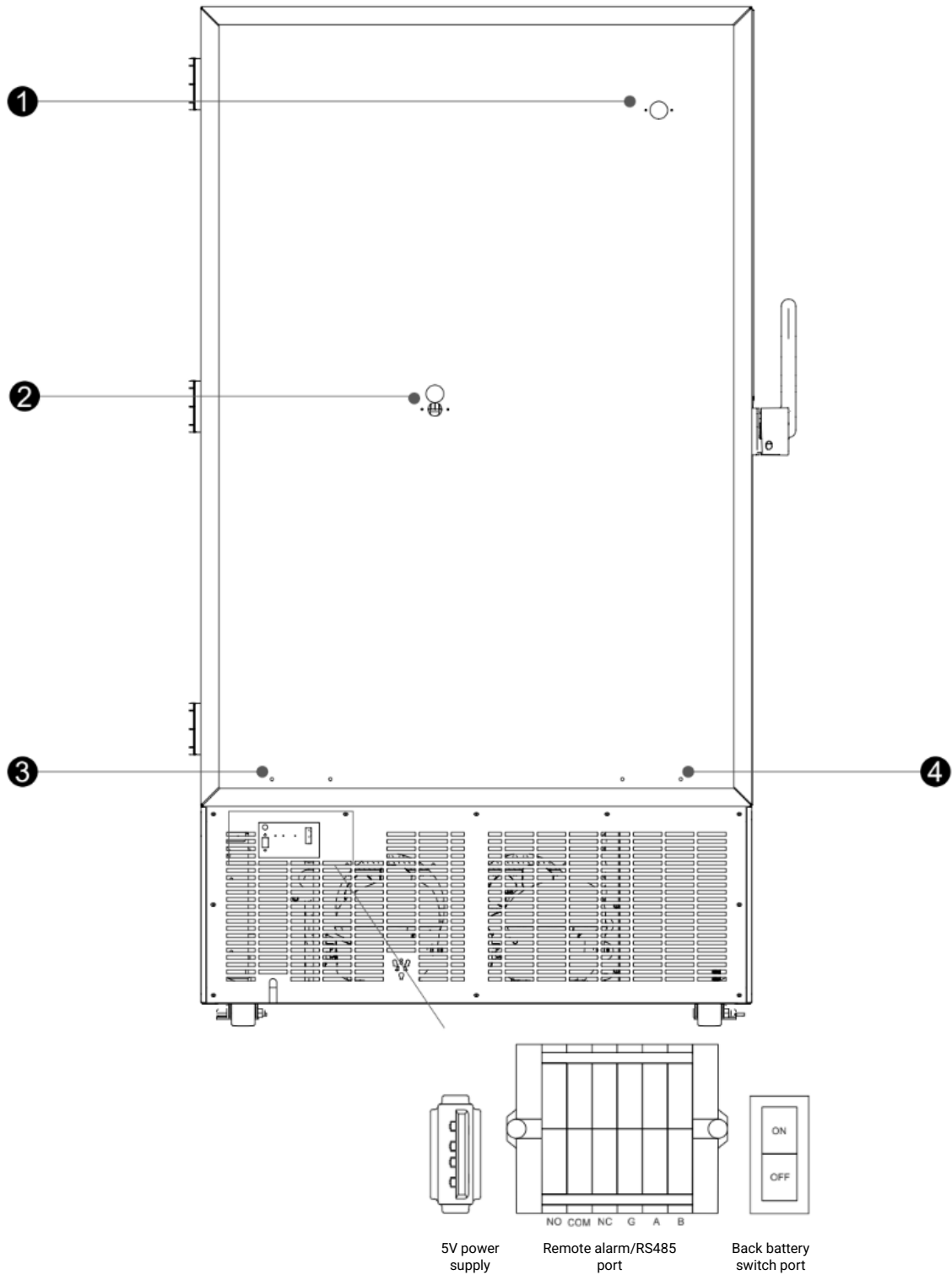

Schematic Diagram (rear view and partial view)

- 1. Testing Hole 1
- 2. Testing Hole 2

- 3. Limit Bracket Mounting Hole 1
- 4. Limit Bracket Mounting Hole 2

Due to ongoing product improvements and variations between models, the actual product may differ slightly from the diagrams shown. Always refer to the actual unit for accurate details.

The diagrams are intended only as a general reference for identifying functional parts.

Operations

Create a User

1. When using the machine for the first time, you must create user accounts.

Two account types are available:

- Administrator account (Level 1)
- Standard user account (Level 2)

The administrator has full access to all settings and system functions.

1.1 Add Administrator

After the machine starts up:

Tap the Settings icon at the bottom of the home screen and then tap User Setting to enter the user creation interface.

(See Figure 1.)

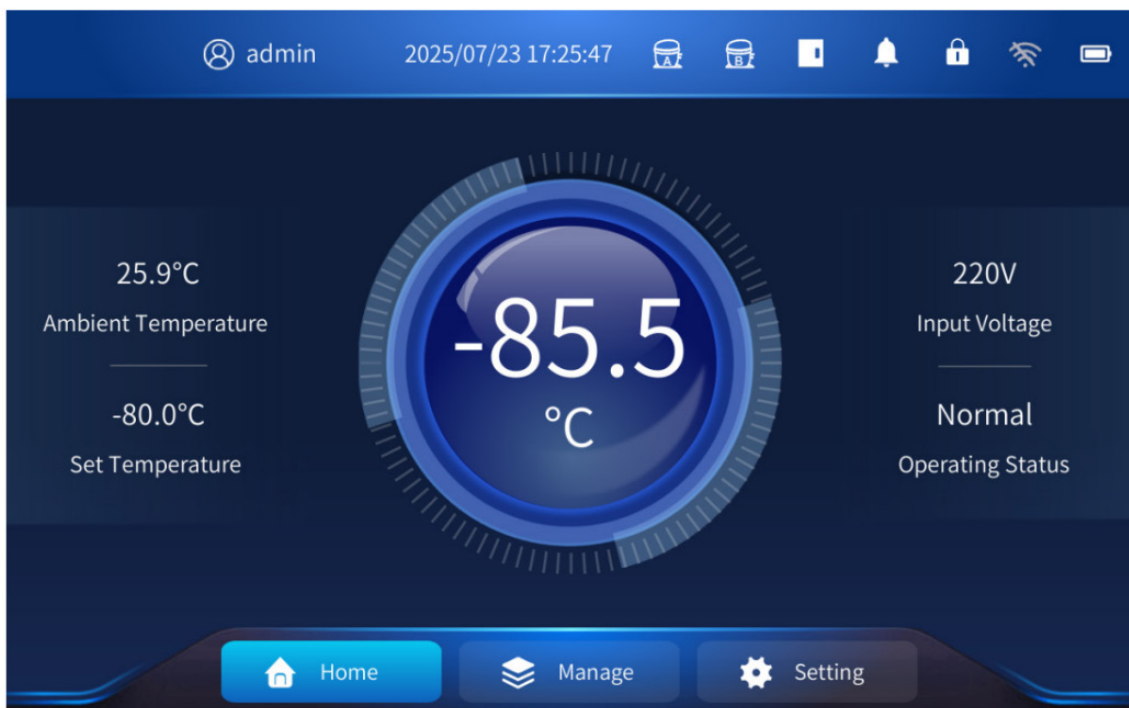

(Figure 1)

In the permissions area, select Administrator for the account type.

Enter the required information:

- Account name
- Password
- Confirm password

Tap Confirm to complete the administrator setup.

(See Figure 2)

The screenshot shows a mobile application interface with a dark blue header. The header contains a back arrow, a 'Login' button with a user icon, the date and time '2025/06/23 18:19:44', and several status icons (signal strength, Wi-Fi, battery, lock, and a red notification bell). Below the header is a white card titled 'Input user info'. The card contains six input fields: 'Account name' with placeholder text 'Please input account name', 'Enter password' with 'Please input a password', 'Confirm password' with 'Please enter the password again', 'Input face' with 'Please place your face on the face module', 'Input card number' with 'Please place your card on the card reader', and 'Input fingerprint' with 'Click to enter fingerprint' and a fingerprint icon. At the bottom of the card are three buttons: 'Face reset', 'Fingerprint reset', and a blue 'Confirm' button.

(Figure 2)

1.2 Adding Common User

You must be logged in to the administrator account before creating an common (Level 2) user. Multiple ordinary user accounts may be created as needed.

Note: Passwords must be 8–16 characters in length.

This screenshot is identical to Figure 2, showing the 'Input user info' form in a mobile application. The header and form elements are the same as described in Figure 2.

(Figure 3)

1.2 Delete User

After logging in with the administrator account, go to the user settings page. Select the account you want to remove and click the corresponding Delete button.

Please note that Common (Level 2) users do not have permission to delete other user accounts.

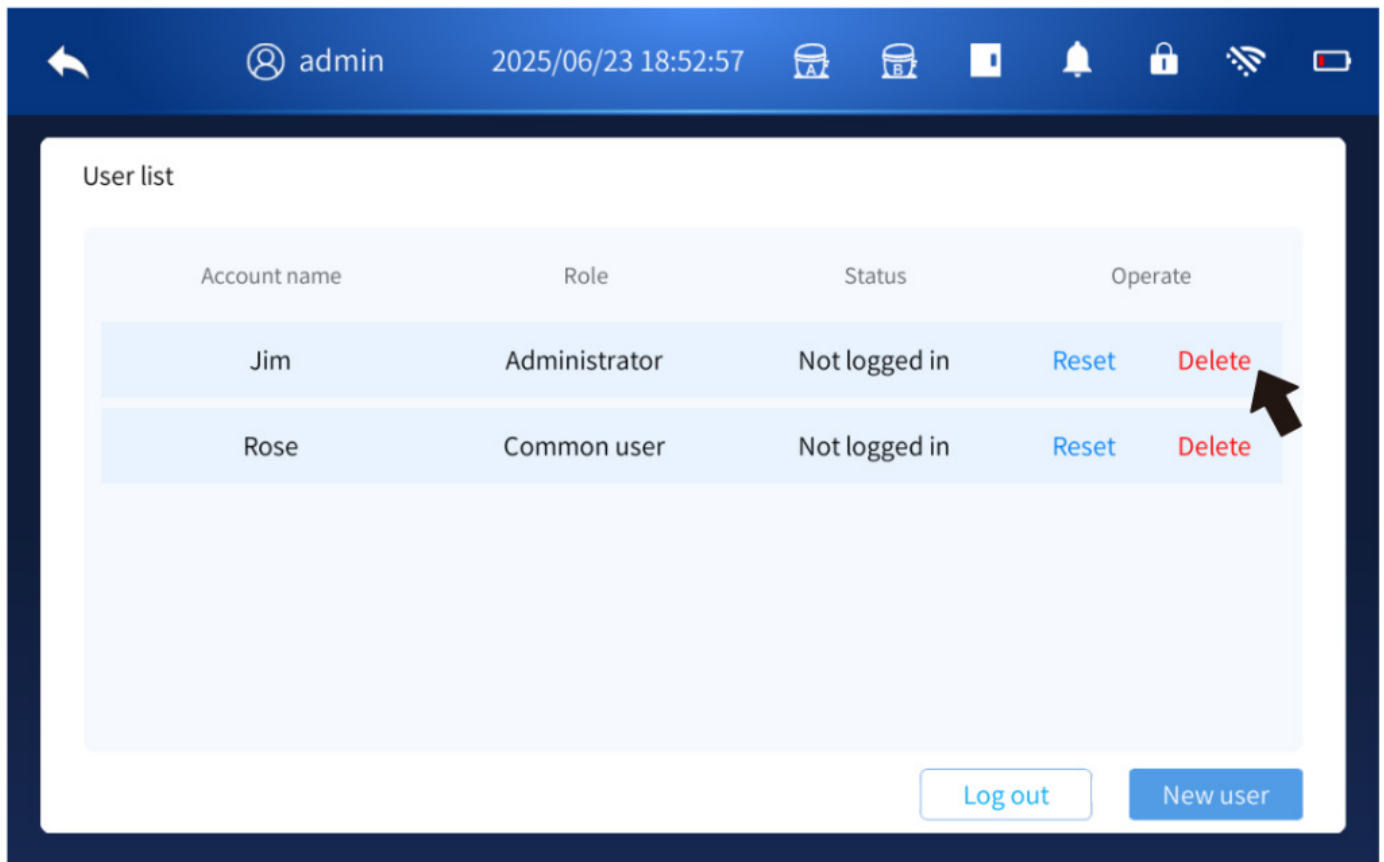

(Figure 4)

1.3 Modify / Reset Password

All users can open the user list page while logged in to modify or reset their passwords.

Administrator Mode:

Click the Reset button next to a common user's name to reset that user's password.

After resetting, the password will be 12345678.

Any Common Account:

When logged in, click the Edit button next to your own user name to change your password.

Passwords may include letters, numbers, and symbols.

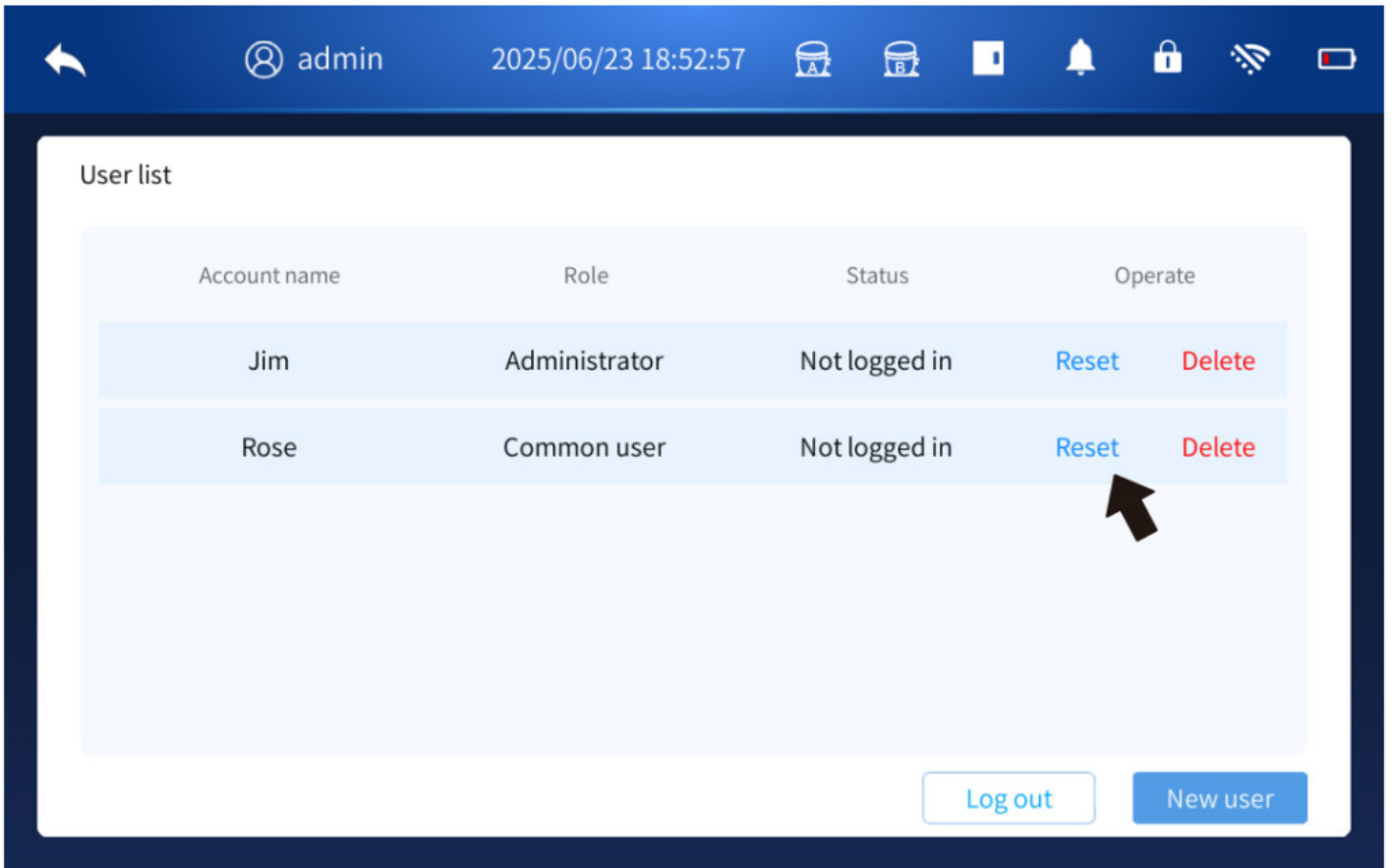

(Figure 5)

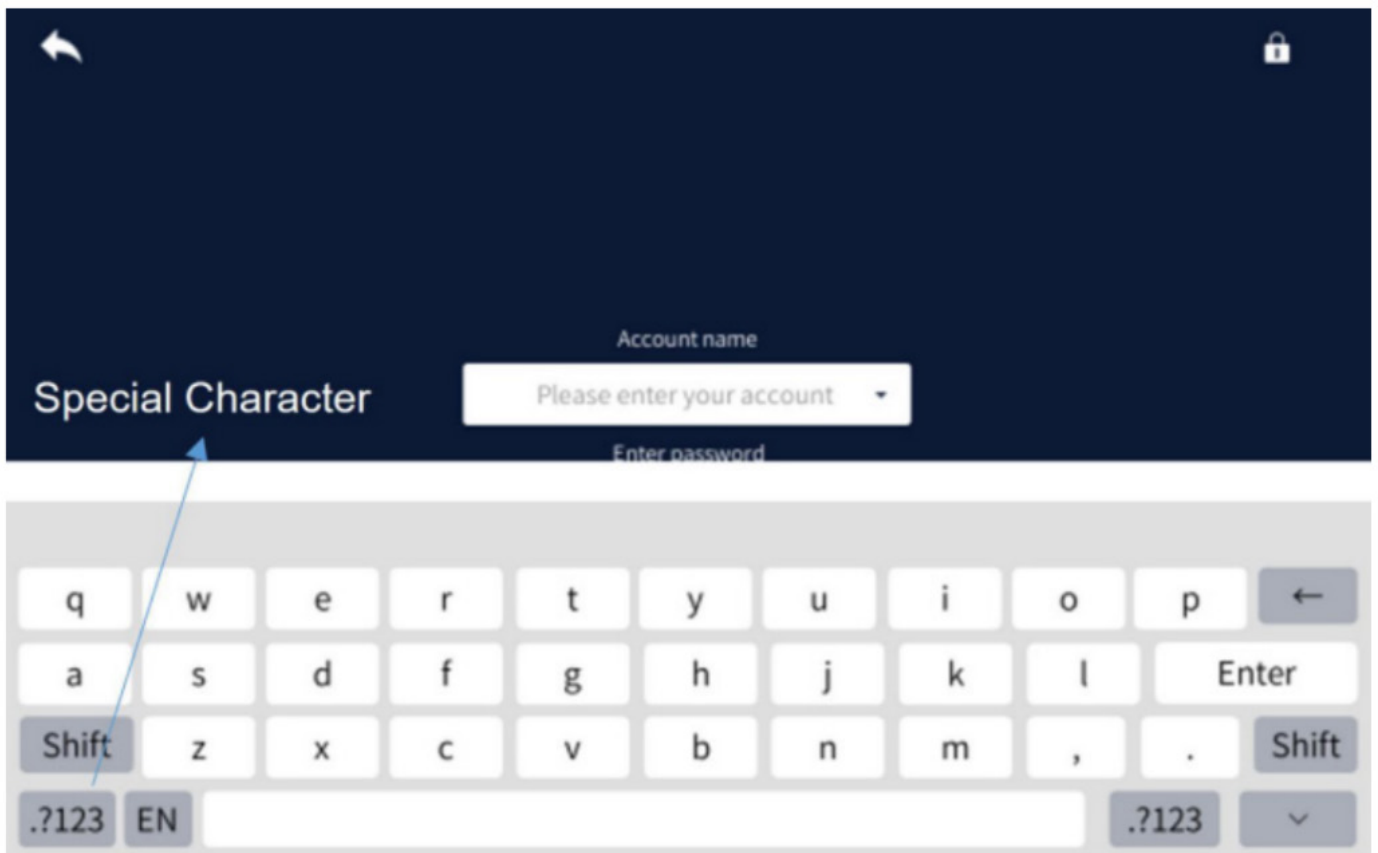

(Figure 6)

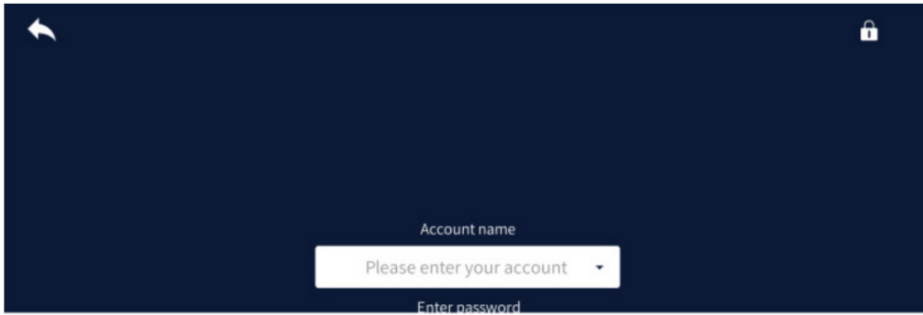

(Figure 7)

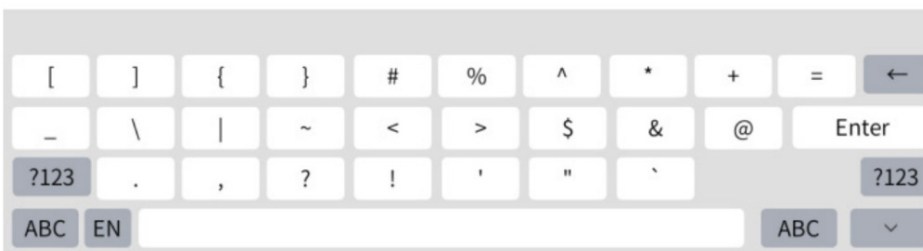
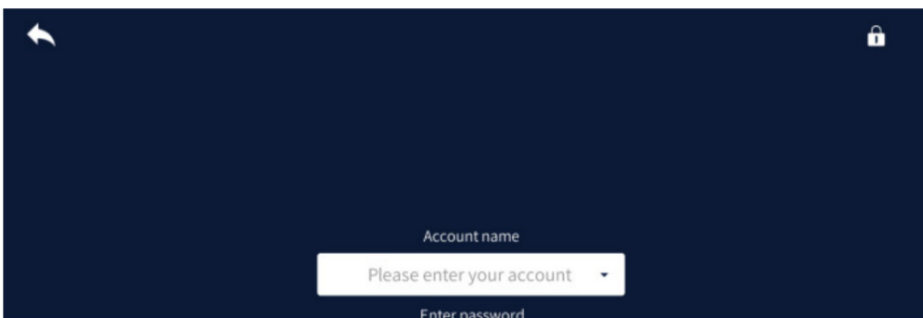

(Figure 8)

Note: Password modification or reset can only be performed while the user is logged in.

1.4 Log In

You can now log in using the account and password you created.

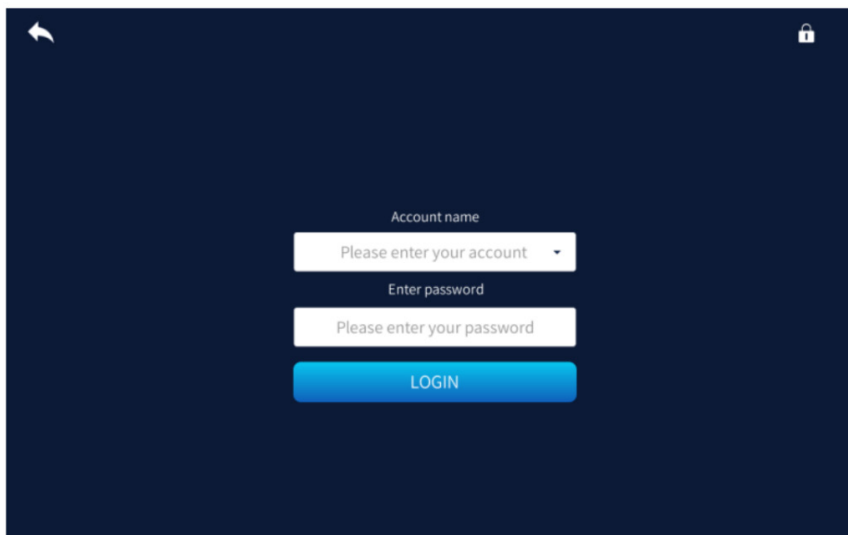

(Figure 9)

Settings

2. Settings

- Select “Settings” on the home screen to access the available configuration menus, including Sample Settings, Operation Settings, System Settings, Network Settings, and User Settings. Options that appear in blue are active and can be adjusted, while options shown in gray indicate functions that are not currently available for this model or configuration.

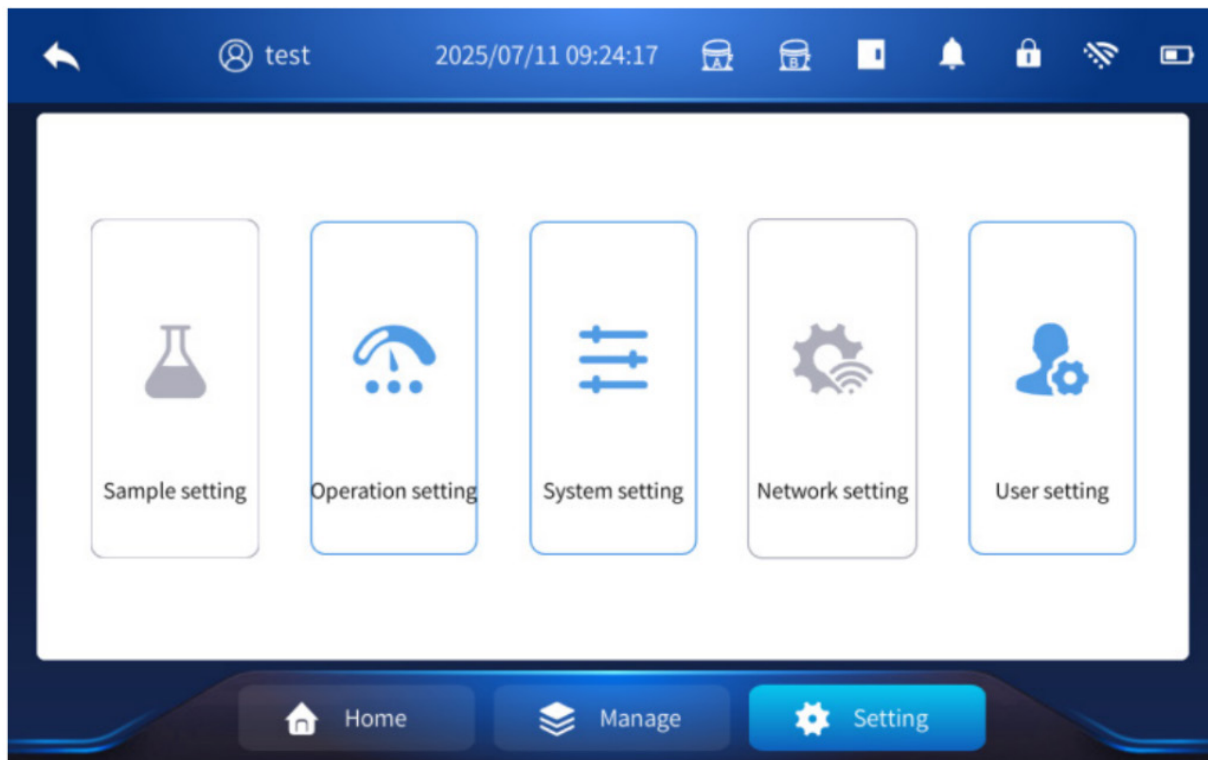

(Figure 10)

2.1 System Settings

Enter the system setting interface, as shown in Figure 11 below, and you can set the following functions:

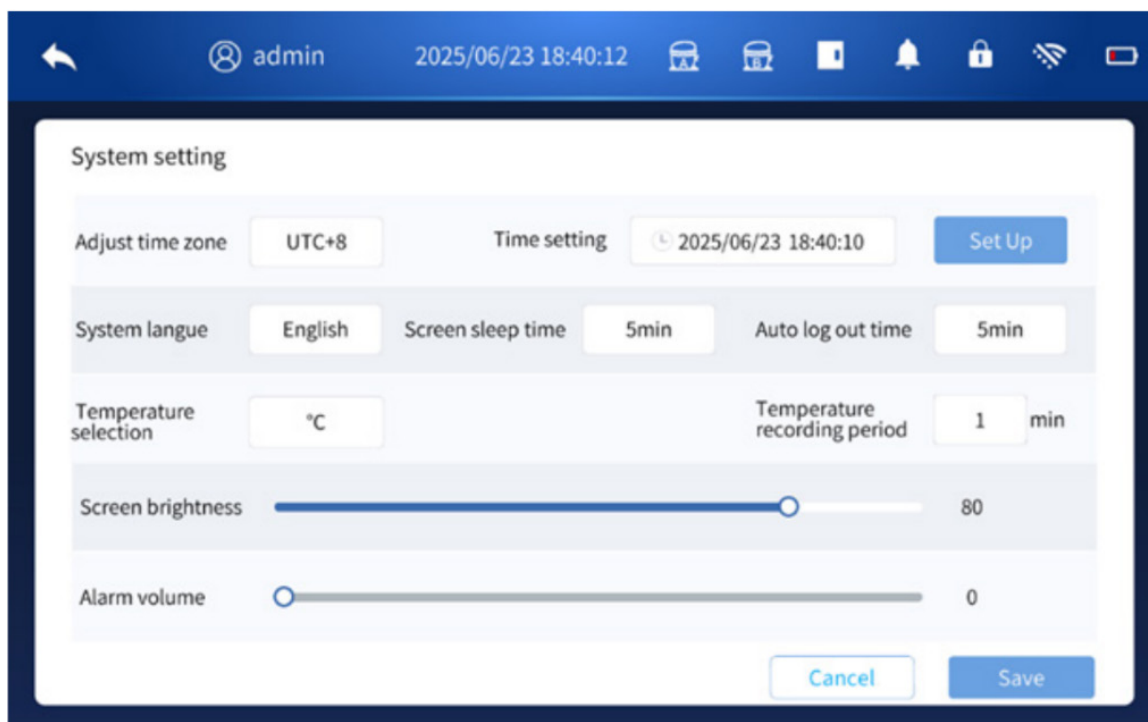

(Figure 11)

2.1.1 Time Setting

- Go to Setting → System Setting, then tap Time setting pop-up.
- Enter the current local time, then tap Set Up.
- A pop-up window will ask to restart the controller. Tap Confirm Restart to apply the new time.

Example (UTC+8):

If your local time is 16:58:03, enter 08:58:03 in the time field and tap Set Up.

After a restart, the system will display the equivalent UTC time at the top.

Because UTC+8 is 8 hours ahead, the displayed time becomes:

$$16:58:03 = 08:58:03 + 8 \text{ hours}$$

This is normal and indicates the time was set correctly.

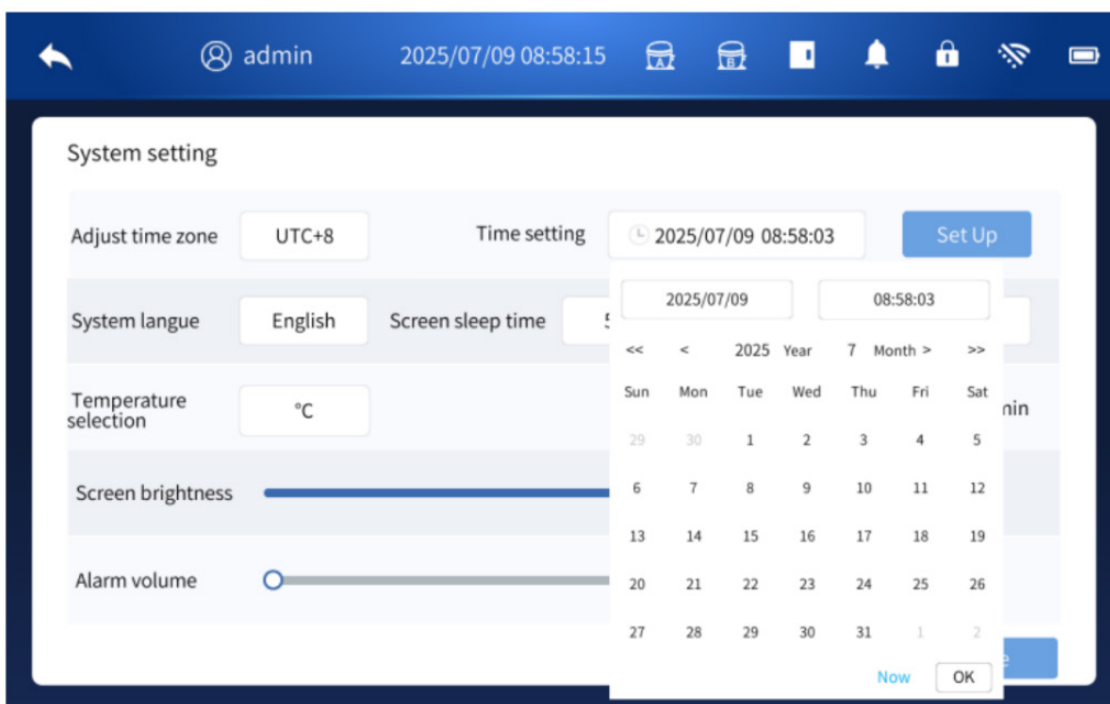

(Figure 12)

2.1.2 Time Zone Setting

- The default time zone is **UTC+8**.
- To change it, go to **Setting** → **System Setting**, then tap **Adjust Time Zone**.
- Select the correct time zone (UTC-12 to UTC+12) and tap **Set Up**.
- A pop-up will ask to restart the controller. Tap **Confirm Restart** to apply the change.

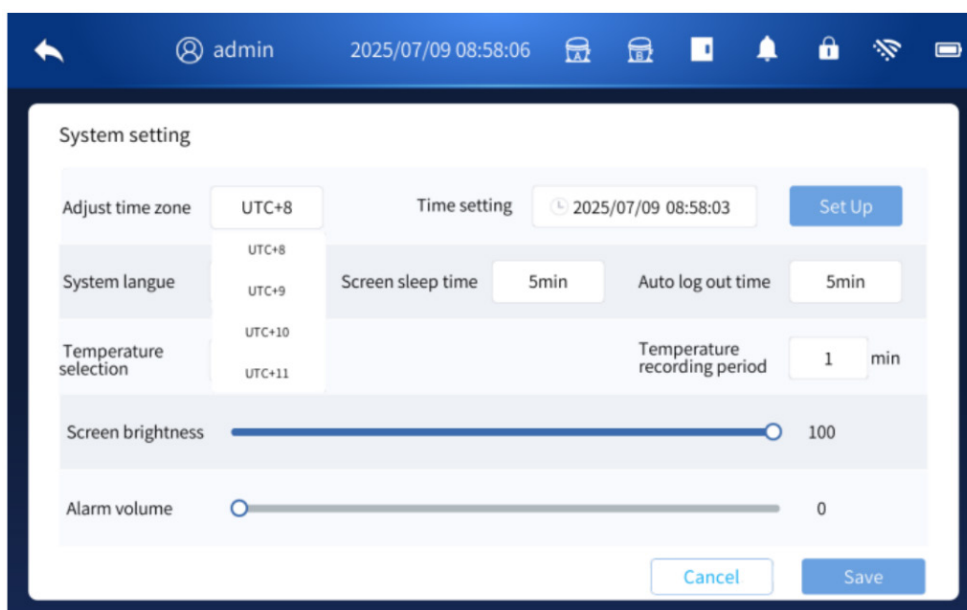

(Figure 13)

2.1.3 Temperature Recording Period Setting

- To set the temperature recording cycle, go to Settings → System Setting.
- Enter the desired interval (1–240 minutes) in the temperature recording period field, then click Save to apply the setting.

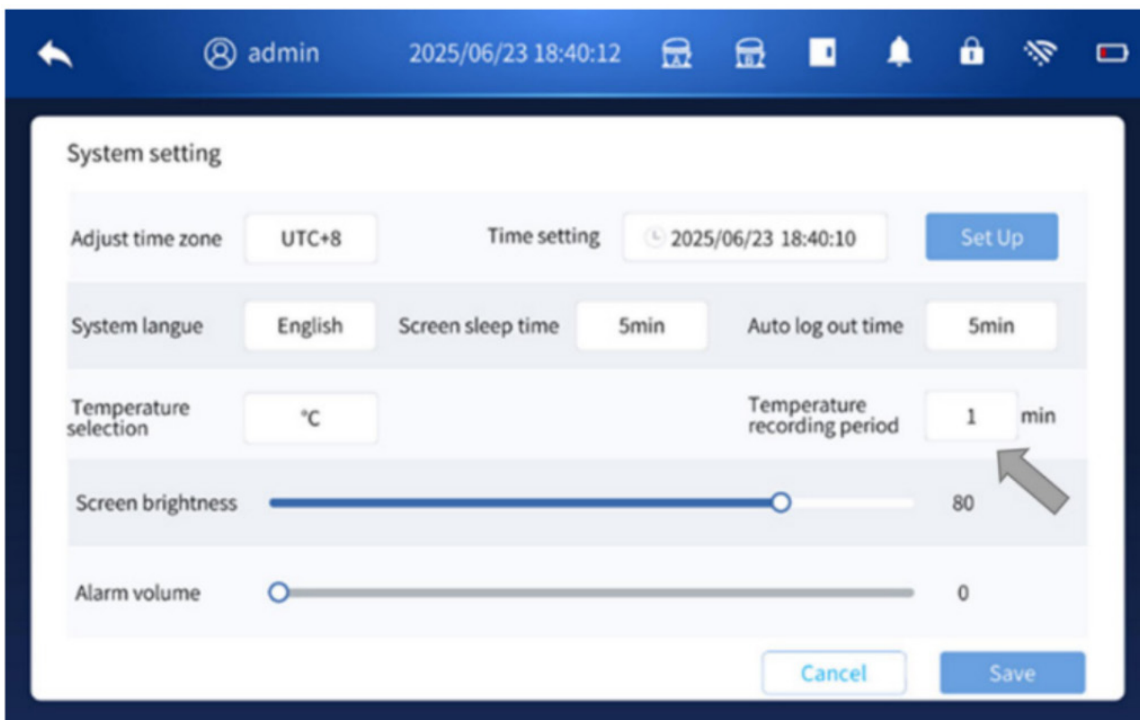

(Figure 14)

2.1.4 Language Setting

- To change the language, go to Settings → System Setting.
- Select the desired language in the language menu, then click Save to apply the setting.

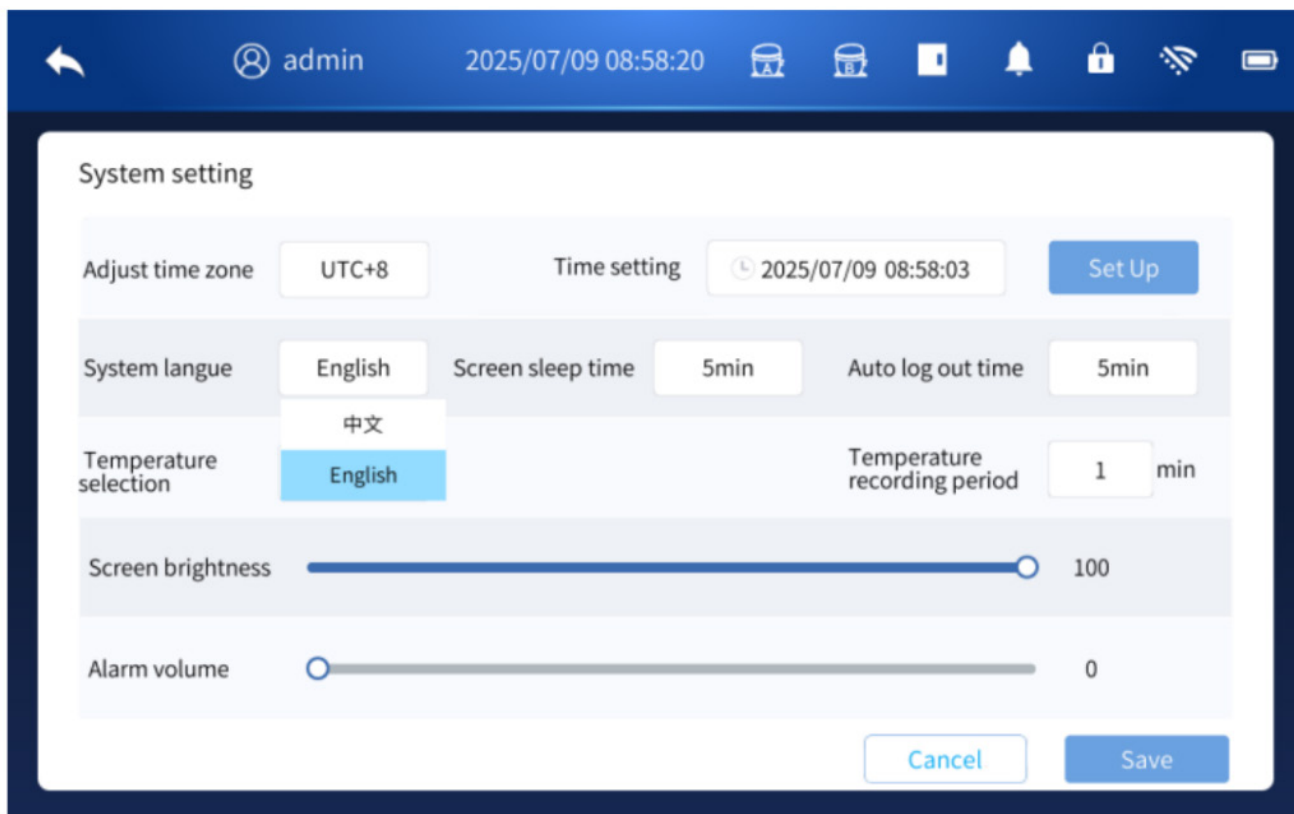

(Figure 15)

2.1.5 Screen Sleep Time Setting

- To adjust the screen sleep time, go to Settings → System Setting.
- Select the desired sleep duration, then click Save to apply the setting.

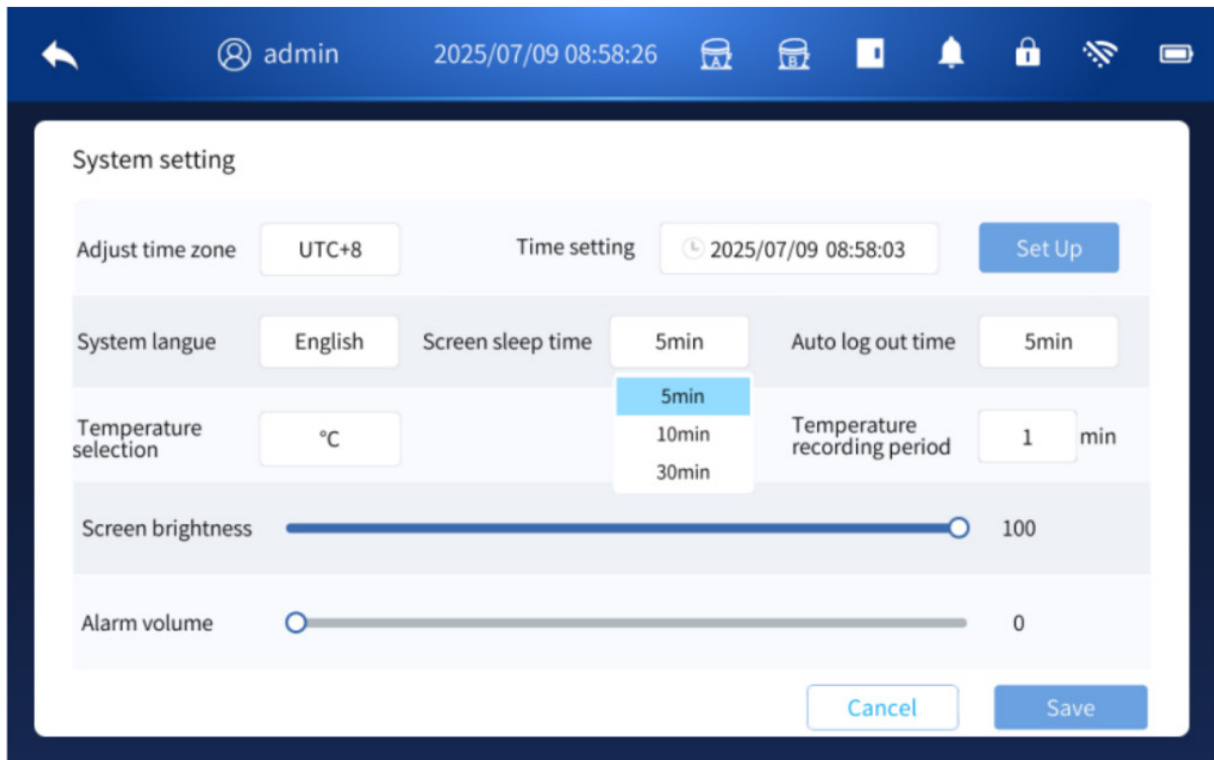

(Figure 16)

2.1.6 Auto Log-Out Time Setting

- To set the automatic log-out time, go to Settings → System Setting.
- Select the desired log-out interval in the auto log-out time field, then click Save to apply the setting.

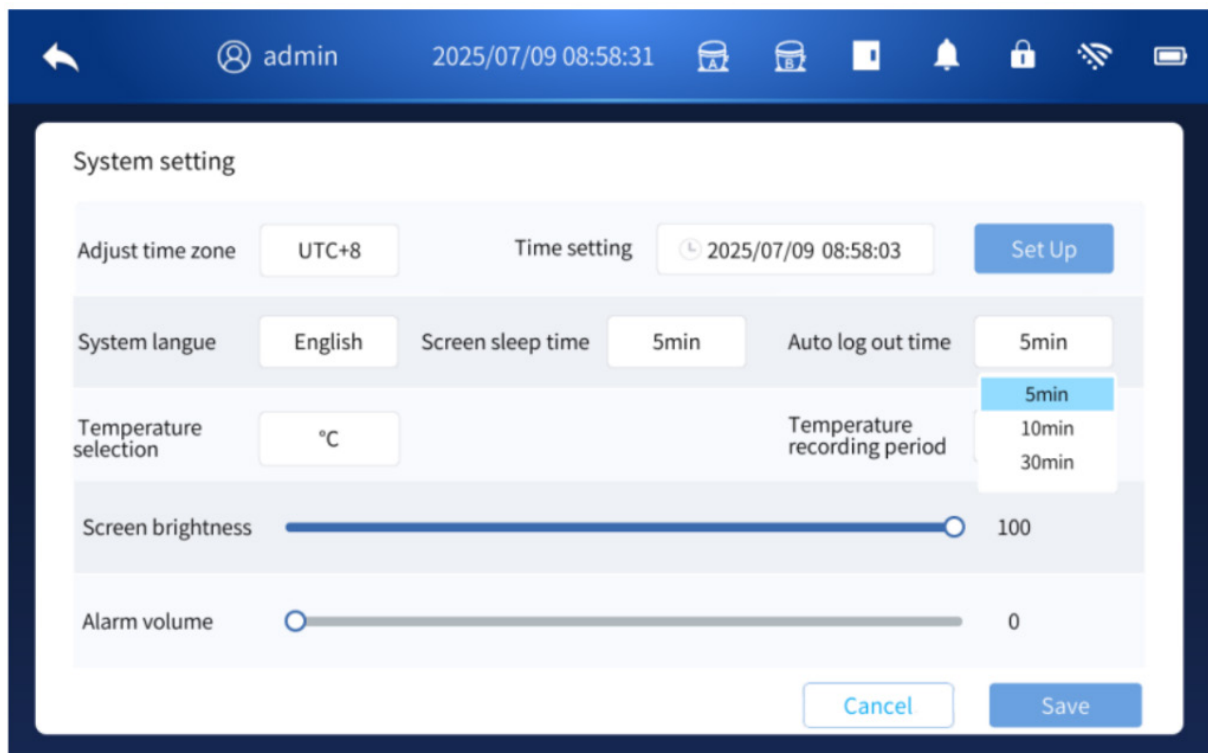

(Figure 17)

2.1.7 Temperature Unit Setting

- To change the temperature display unit, go to Settings → System Setting.
- Select the desired unit (°C or °F) in the temperature unit menu, then click Save to apply the setting.

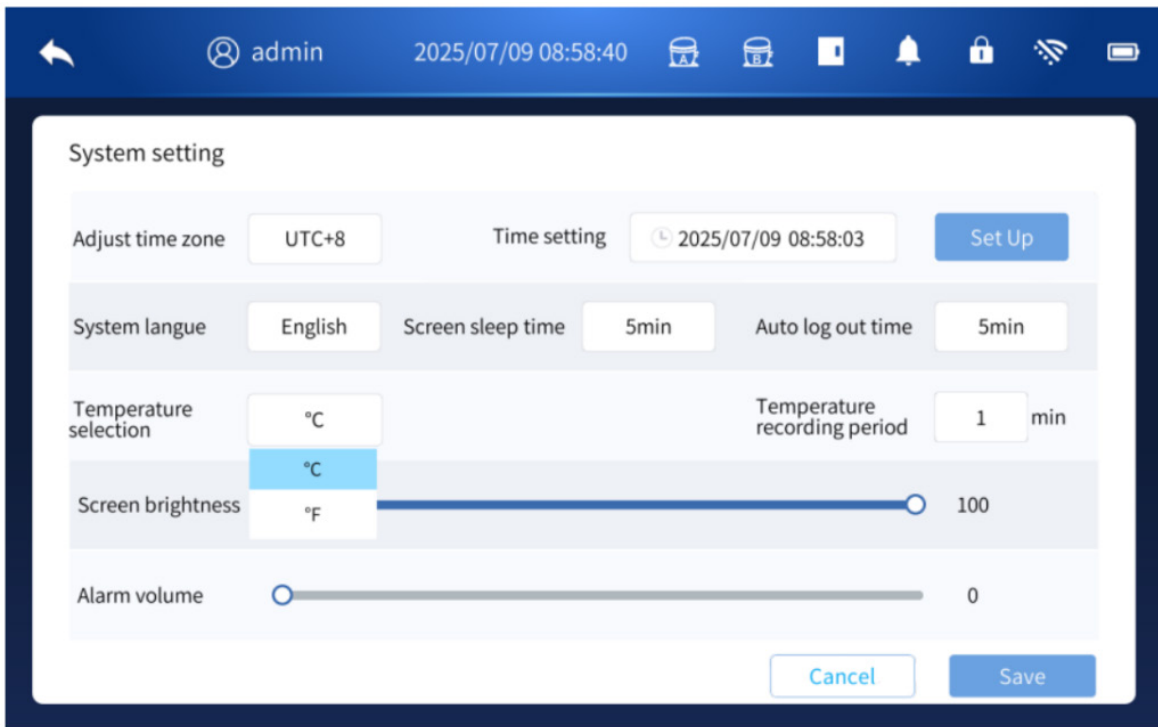

(Figure 18)

2.1.8 Screen Brightness Setting

- To adjust the screen brightness, go to Settings → System Setting.
- Use the slider to set the desired brightness level, then click Save to confirm the setting.

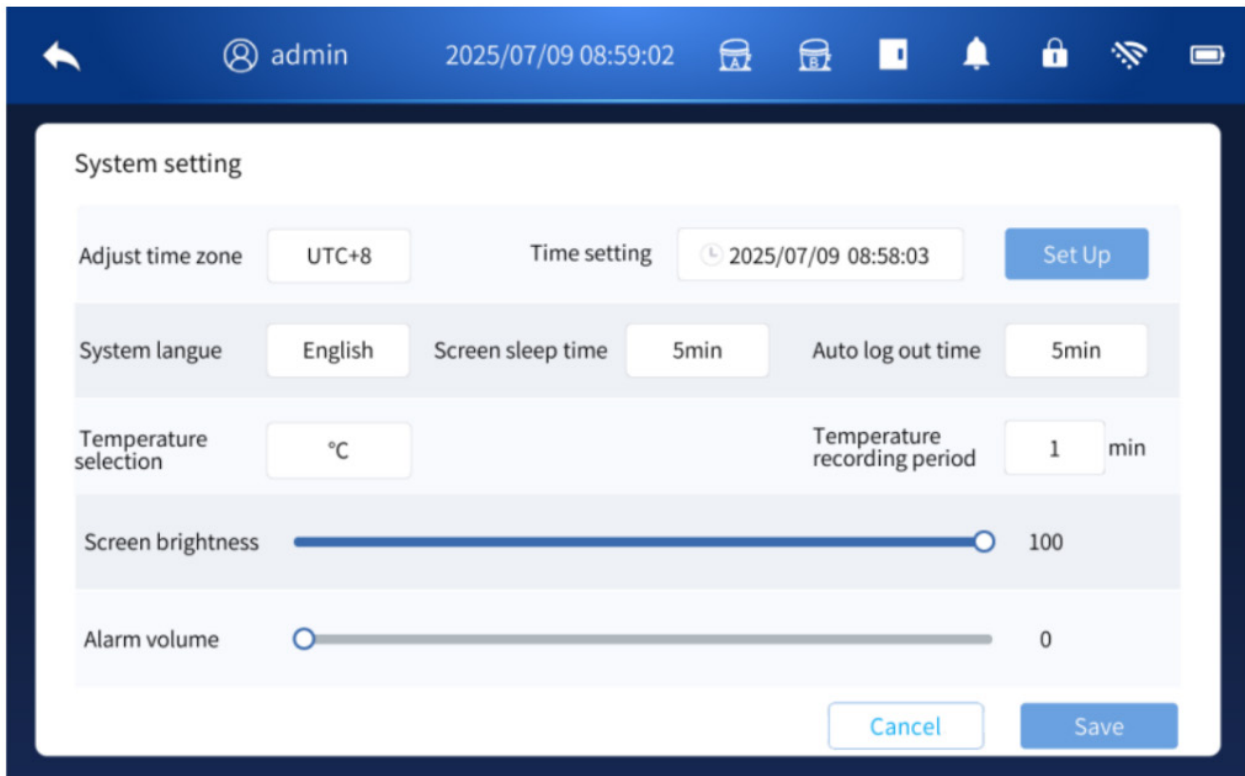

(Figure 19)

2.1.9 Alarm Volume Setting

- To adjust the alarm volume, go to Settings → System Setting.
- Use the slider to select the desired volume level, then click Save to apply the setting.

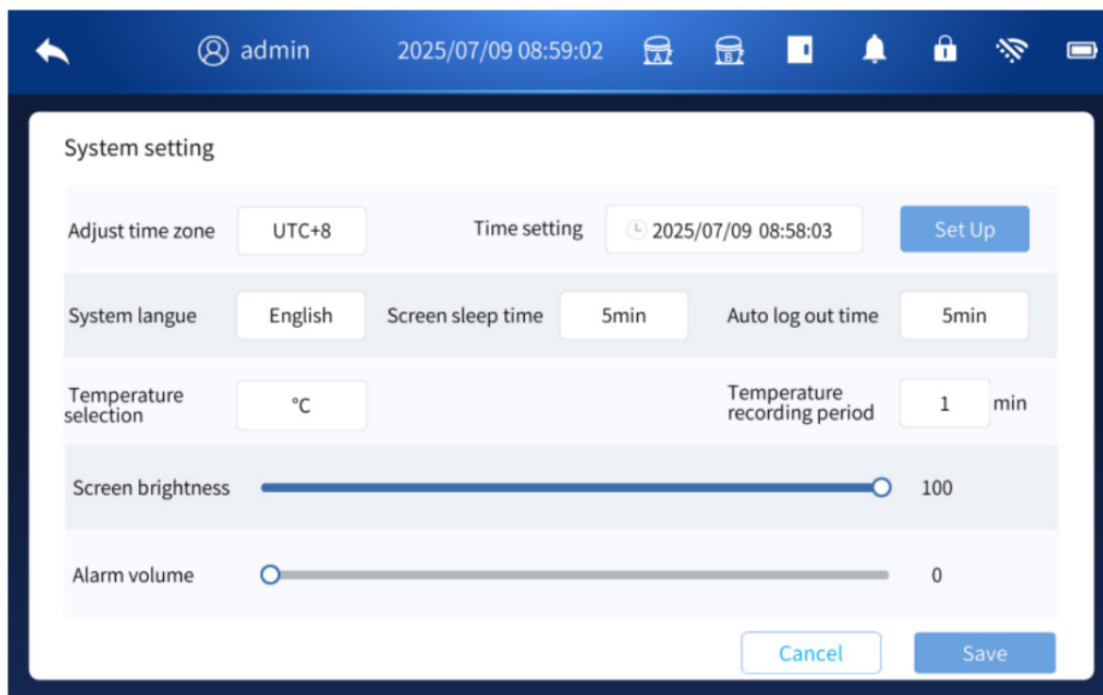

(Figure 20)

2.2 Operation Parameter Settings

After logging in, go to Settings → Operation Setting. In this menu, you can adjust the following parameters:

- Set Temperature
- Upper Deviation for High-Temperature Alarm
- Lower Deviation for Low-Temperature Alarm

After entering the desired values, click Save to apply the settings.

If the deviation values for the high- or low-temperature alarms are outside the allowable range, a prompt will appear indicating that the values are invalid.

To disable the high- and low-temperature alarms, set the deviation value to 0°C.

Note: Both common users and administrator users are allowed to modify these settings.

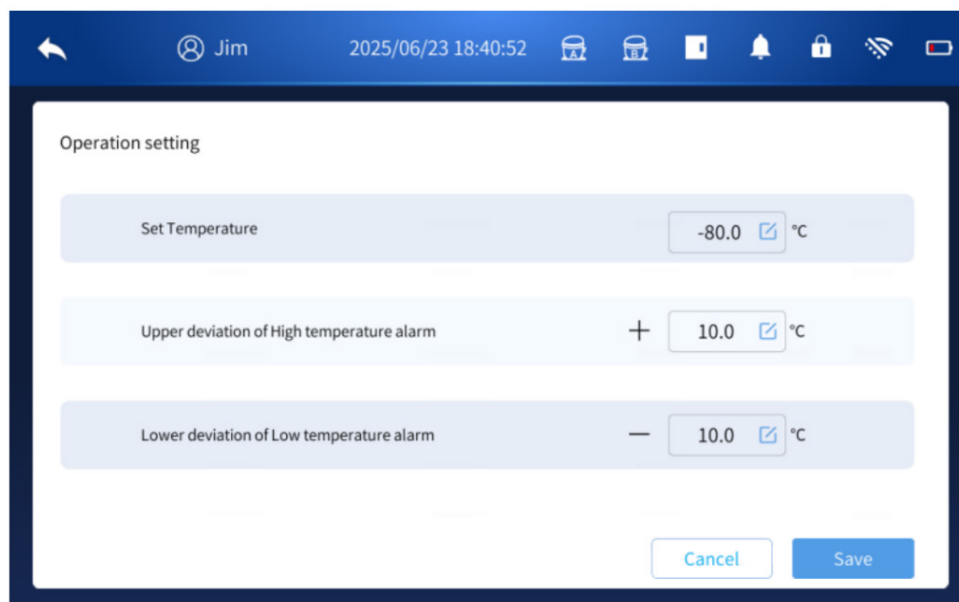

(Figure 21)

2.3 Network Settings

On the Settings → Network Settings page, tap the WIFI Setting switch icon to turn the network on or off. When the network is turned on, select the desired Wi-Fi network from the list and enter the correct password. After a successful connection, the Wi-Fi icon at the top of the screen will update to show the connected status. (See attached image for an example of a successful connection.)

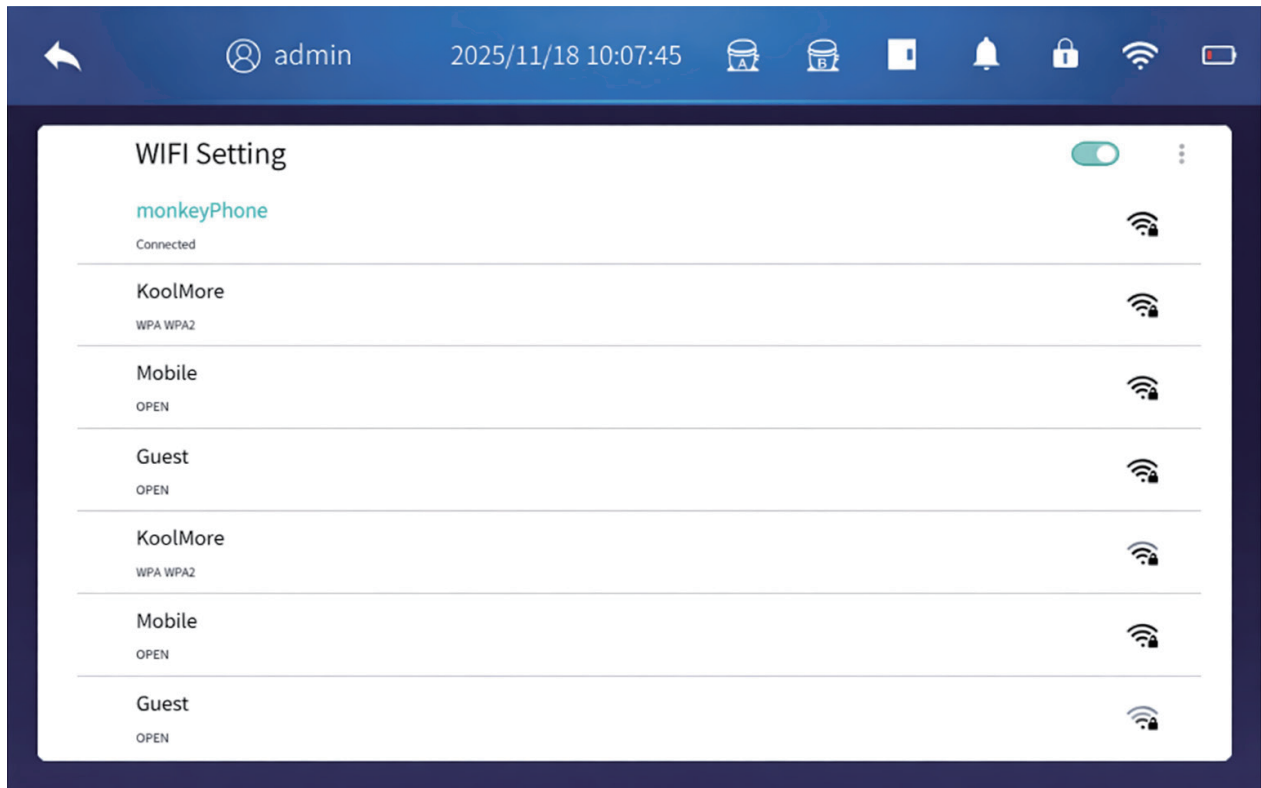

(Figure 22)

Homepage Display

3. Homepage Display

Under normal conditions, the homepage appears as shown in the figure below. The homepage includes the following display parameters and menu options:



- Ambient Temperature – The temperature of the environment where the product is installed.
- Set Temperature – The temperature value configured by the user.
- Input Voltage – The current input voltage supplied to the unit.
- Operating Status – Indicates whether the unit is functioning normally.
- Cabinet Temperature – The real-time internal temperature of the product.
- Home – Returns to the homepage display.
- Manage – Provides access to alarm information, messages, temperature records, event records, operating status, and local device information.
- Setting – Allows configuration of system parameters, operation parameters, and user account management.







(Figure 23)

3.1 Top Icon Display

- **Door Opening and Closing Status**



-  Indicates door open.
-  Indicates door closed.

- **Alarm Icon Status**





-  Indicates normal condition (no alarm).
-  Indicates mute mode.
-  Indicates an active alarm. When an alarm occurs, the buzzer will sound.
-  Tap the alarm icon to temporarily mute the buzzer; the icon will change to the mute symbol.

If the alarm condition is still present after 10 minutes, the buzzer will automatically unmute.



- **Network Status**

-  Indicates not connected to a network.
-  Indicates network connected.

- **Compressor Status**

-  /  Indicates normal operation of system A/B.
-  /  Indicates a compressor fault in system A/B.

- **Battery Status**

-  Indicates the battery is fully charged.
-  Indicates the battery is low and needs to be charged as soon as possible.

3.2 Alarm Status

3.2.1 Alarm Status

- When the freezer is operating abnormally (such as during a high-temperature alarm, low-temperature alarm, door-open alarm, or system failure), the central operating status indicator turns orange (normal status is blue). An alarm pop-up window will appear, and the buzzer will sound.
- When an alarm occurs, you may close the alarm pop-up window or tap the Alarm Bell icon  to temporarily mute the alarm sound.

3.2.2 Alarm view

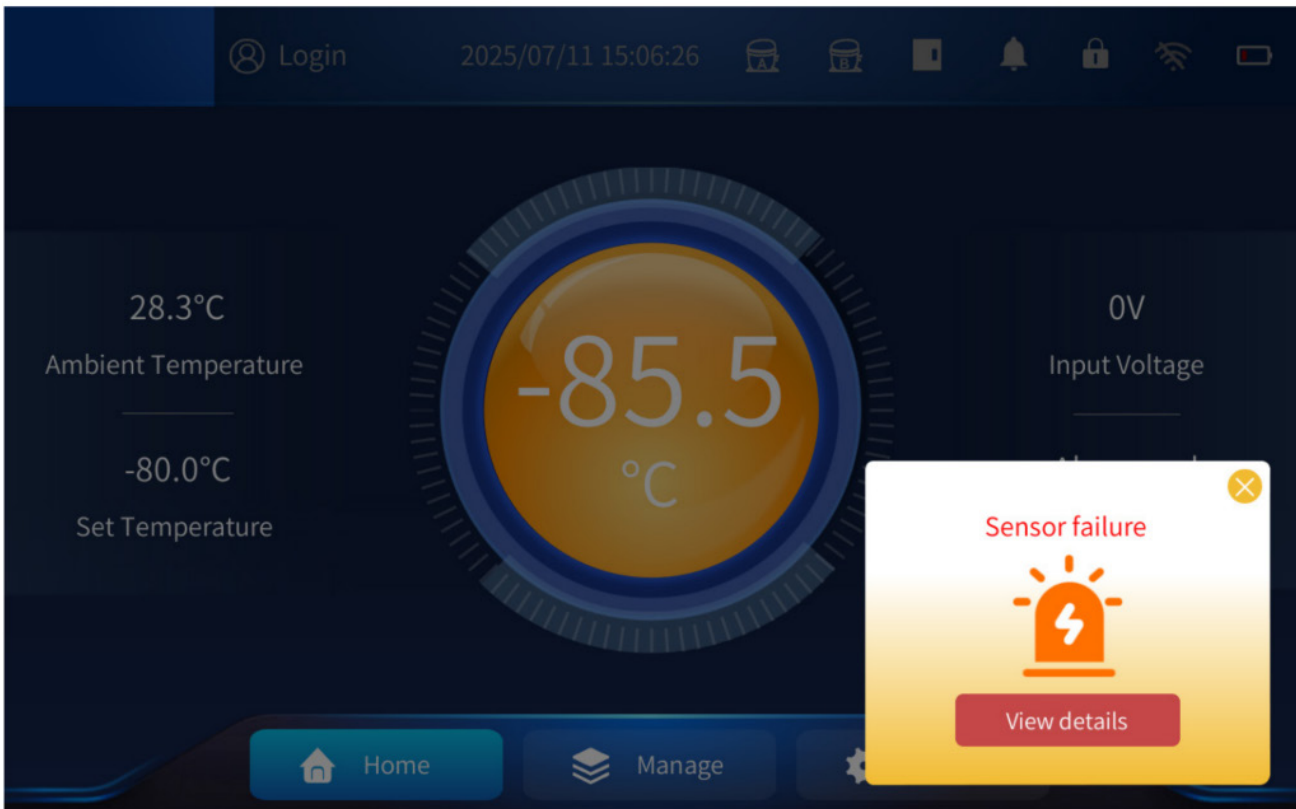

(Figure 24)

Click View Details in the alarm window to see additional alarm information, or click the X in the upper-right corner to close the pop-up window. If the alarm condition still exists after 10 minutes, the alarm window will reappear and the buzzer will sound again.

You can also manually check alarm records by going to Manage - Alarms - All Alarm.

While logged in, select a Start and End time, then click Search to display alarm information for that time period.

To export the alarm records, insert a USB flash drive and click Download to save the data to the USB.

Note: Both common users and administrator users can adjust this setting.

The screenshot shows a mobile application interface for alarm management. At the top, there is a navigation bar with a back arrow, a 'Login' button, the date and time '2025/07/11 14:58:24', and several status icons. Below the navigation bar, there is a sidebar menu on the left with options: 'All alarm' (selected), 'Temperature alarm', 'Door open alarm', 'Communication alarm', 'Power failure alarm', 'Sensor failure alarm', and 'System failure alarm'. The main content area features a search and filter section with 'Time' (Start to End), a 'Search' button, and a 'Download' button. Below this is a table of alarm events.

Time	Event
2025/07/11 14:58:08	Env humidity sensor failure
2025/07/11 14:58:08	Low voltage alarm
2025/07/11 14:58:08	Exhaust sensor2 failure
2025/07/11 14:58:08	Exhaust sensor1 failure
2025/07/11 14:58:08	Condenser sensor 2 failure
2025/07/11 14:58:08	Condenser sensor 1 failure
2025/07/11 14:49:24	Low voltage alarm

(Figure 25)

Management Page

4. Management Page

- Click the Manage icon at the bottom of the screen to open the management page. From this menu, you can view alarm information, system messages, temperature records, event records, operating status, and device information.

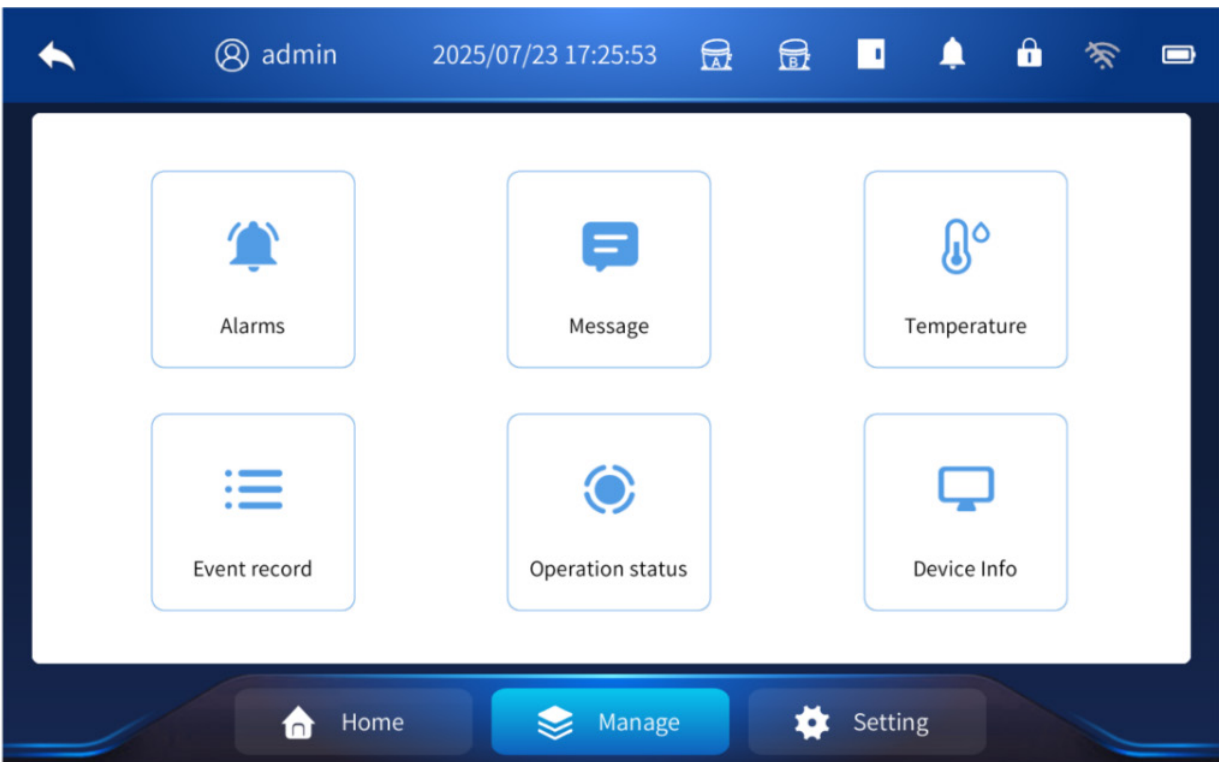

(Figure 26)

4.1 Alarm Information

See the description in Section 3.2.2.

4.2 Temperature

- **Temperature Page Functions:** The temperature page displays the high-temperature alarm upper limit, low-temperature alarm lower limit, maximum temperature, and minimum temperature.
- The maximum and minimum values shown in the upper-right corner represent the highest and lowest temperatures recorded by the cabinet sensor during each temperature-recording interval for the selected time period.
- Exporting Temperature Data (Quick Select): While logged in, insert a USB flash drive.
- Select a time period—2 hours, 24 hours, 7 days, or 1 month—and then click Download to export the temperature data for that period to the USB drive.
- Exporting Temperature Data (Custom Range): You may also choose a custom time range by selecting Start – End, then clicking Search.
- You can then download the corresponding data (in PDF table format) to the USB flash drive.
- **Note:** The custom time range cannot exceed 1 month.

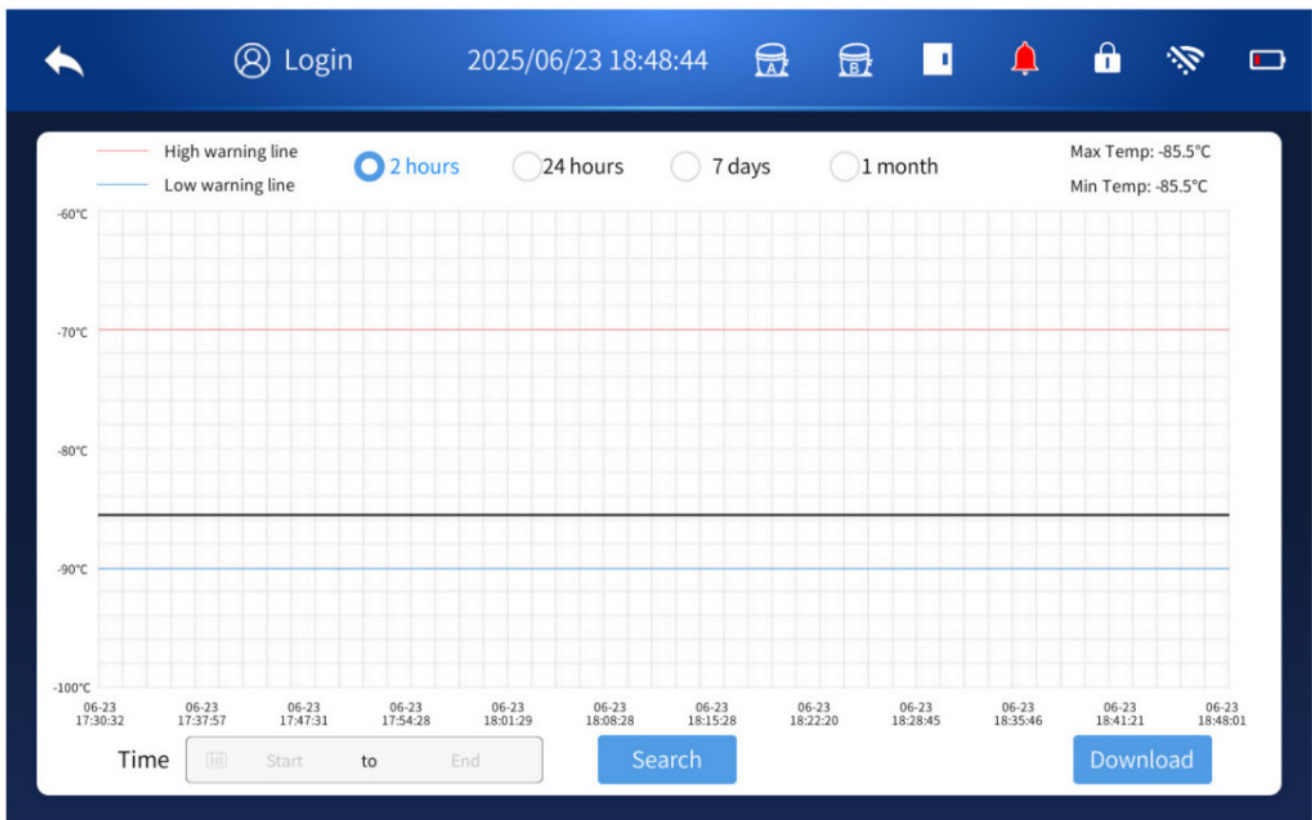

(Figure 27)

4.3 Message System

Different users can leave messages for other users of the machine by logging in with their own accounts. The recipient will receive the message the next time they log in. The process is described below:

4.3.1 Create a New Message:

While logged in, click New (+), select the recipient, and enter your message. After sending, you can check the Outbox to confirm the message status.

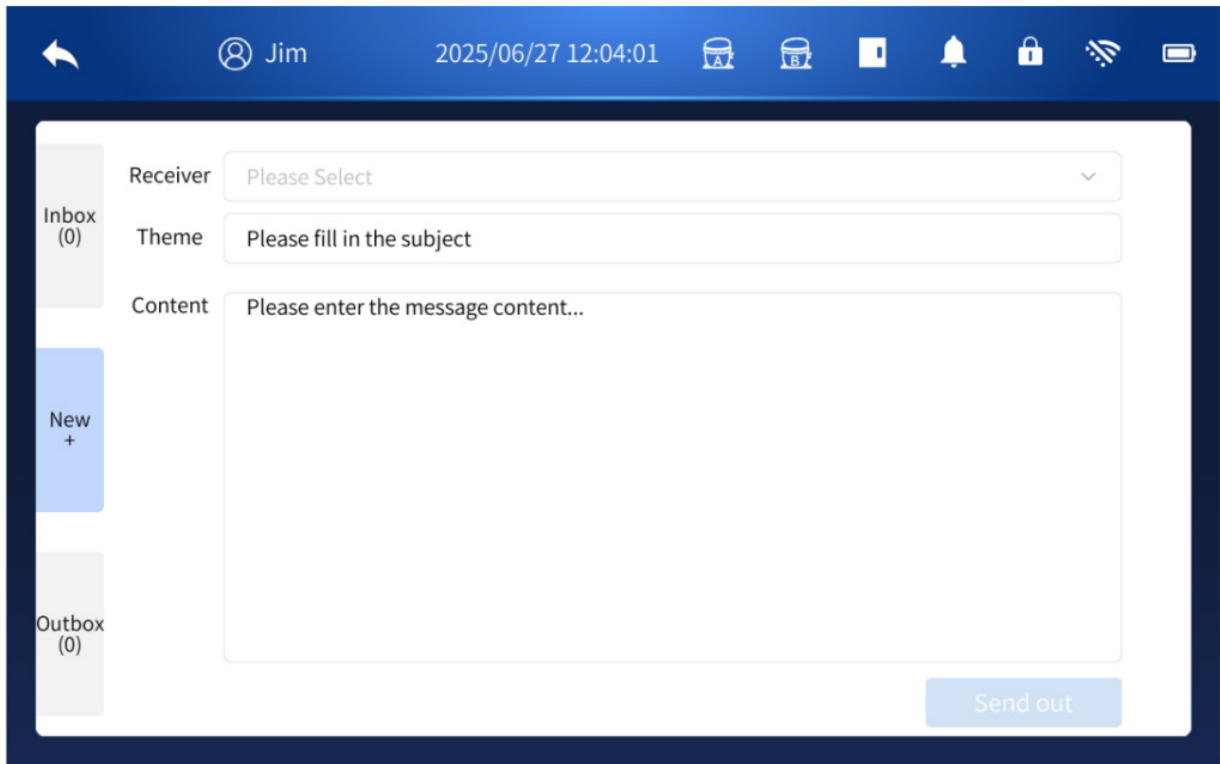

(Figure 28)

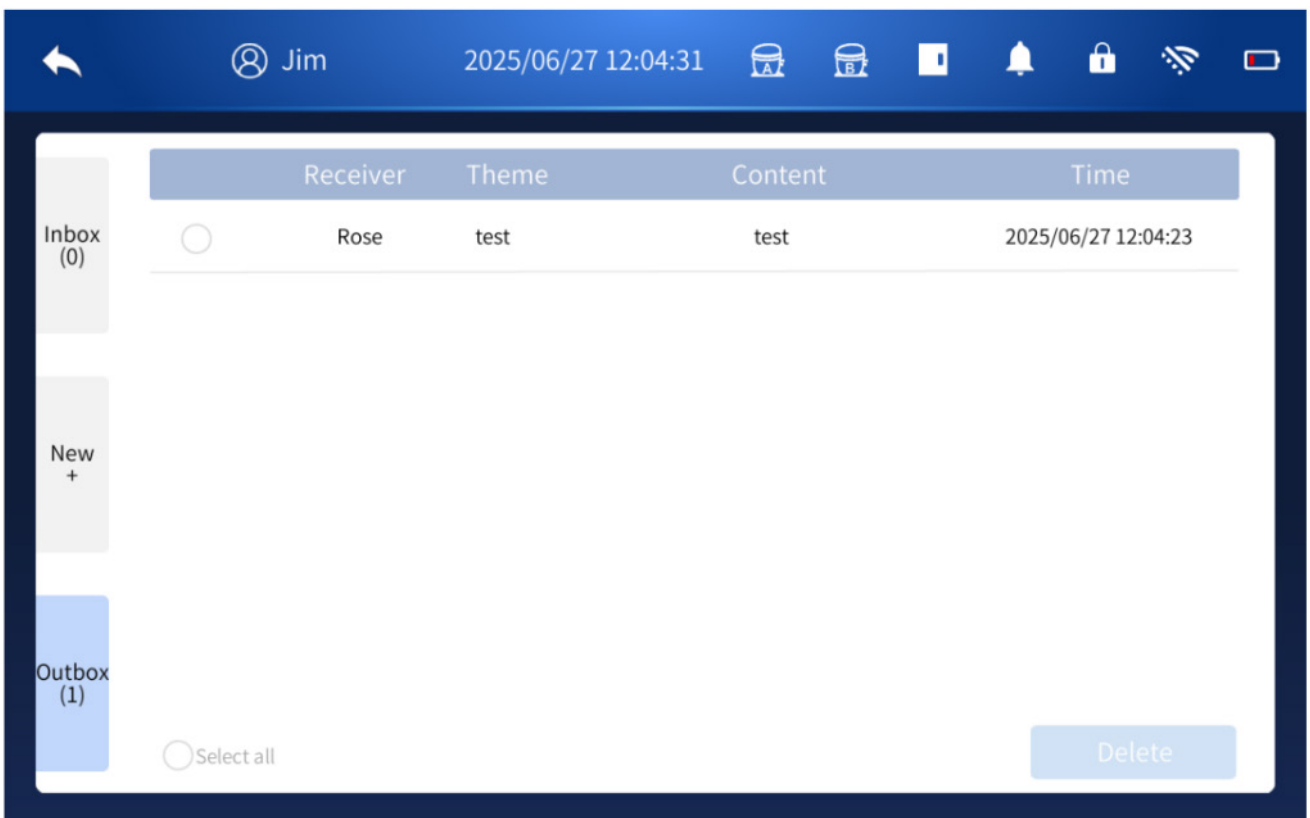

(Figure 29)

4.3.2 Inbox: When the account is logged in, click the inbox to view the message details.

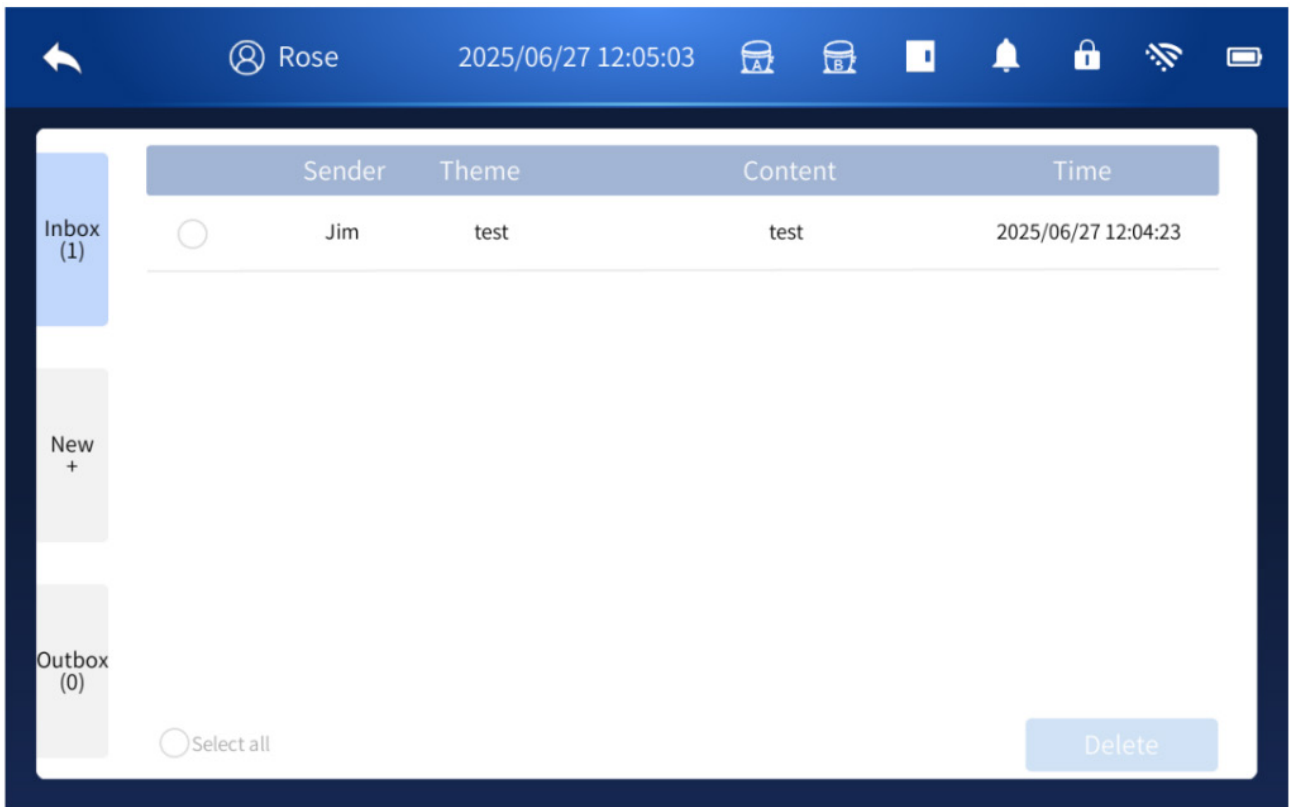

(Figure 30)

4.4 Event Log

- The event record page allows you to view detailed information such as account logins, power outage records, door opening and closing events, and data export records for setting changes.
- While logged in, select a Start and End time, then click Search to display events within that time period.
- To export the event records, insert a USB flash drive and click Download to save the data to the USB.

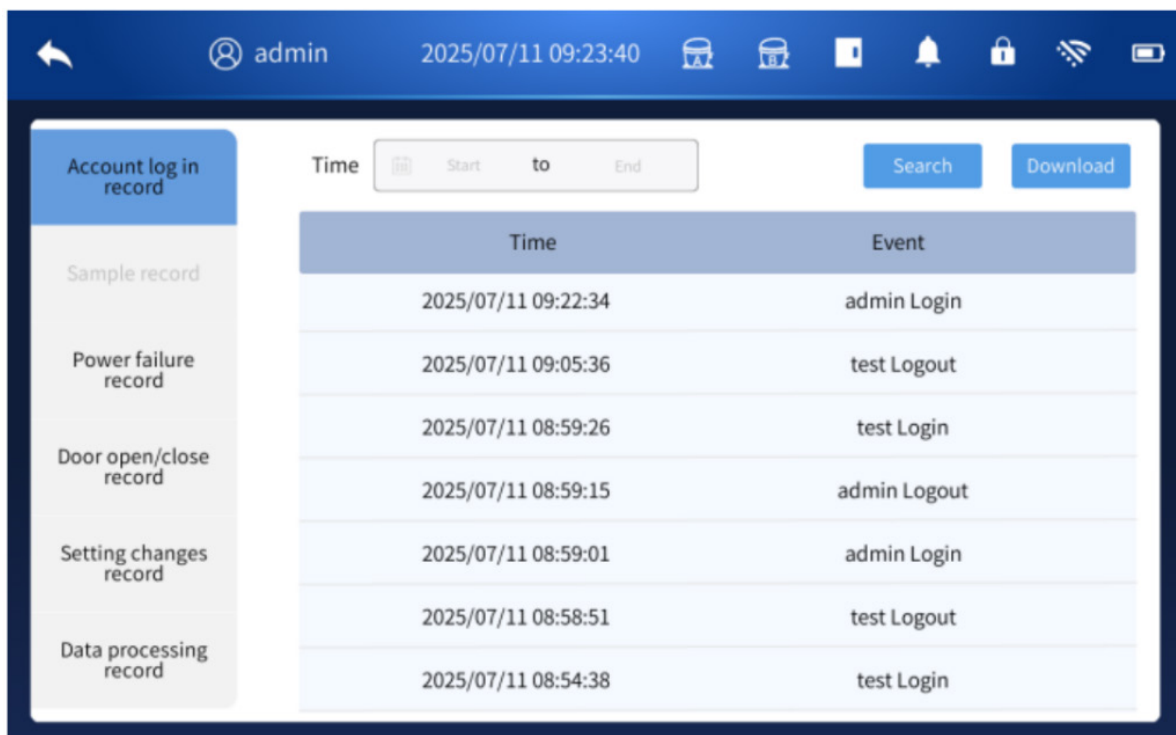

(Figure 31)

4.5 Operation Status

4.5.1 While logged in, click View Details to check sensor readings, including the internal temperature, system A exhaust temperature, system B exhaust temperature, system A condenser temperature, and system B condenser temperature. Selecting View Details displays the temperature monitoring values for each corresponding sensor.

The recording interval for these values can be configured under Settings → System Setting → Temperature Recording Period.

The sensor and system indicators are defined as follows:

- SET – Set temperature
- TP_DIS – Displayed temperature
- TP3 – Ambient temperature
- TP4 – Condenser 1 temperature
- TP5 – Condenser 2 temperature
- TP6 – Exhaust 1 temperature
- TP7 – Exhaust 2 temperature
- P – Total power of the unit
- Uli – Lithium battery voltage
- ERR – Fault alarm code

The detailed meanings of these values are shown below.

Fault Alarm Codes	Fault/Alarm Name	Fault Alarm Codes	Fault/Alarm Name
H1	High temperature alarm	EP	Power supply overvoltage alarm
L1	Low temperature alarm	BL	Low battery alarm
H2	High ambient temperature alarm	EVL	Alarm for low voltage
H3	Alarm for high condenser 1 temperature	EVH	Alarm for high voltage
H4	Condenser 2 high temperature alarm	ESA	System A compressor fault alarm
E1-E8	Sensor fault alarm	ESB	System B compressor fault alarm
do	Door open alarm	PF	Power failure alarm
Eb	Battery overvoltage alarm	EE	Communication abnormality alarm

No.	Time	SET	TP_DIS	TP3	TP4	TP5	TP6	TP7	P	Uli	ERR
1	2025-07-11 09:19:52	-80.0°C	26.0°C	23.9°C	26.1°C	26.3°C	26.5°C	26.2°C	6.0W	10.6V	
2	2025-07-11 09:01:19	-80.0°C	26.4°C	24.5°C	26.3°C	26.7°C	27.1°C	26.2°C	5.0W	10.6V	PF
3	2025-07-11 08:51:27	-80.0°C	27.3°C	26.0°C	27.7°C	28.0°C	28.2°C	28.1°C	5.0W	10.6V	PF
4	2025-07-10 16:59:34	-80.0°C	26.0°C	24.5°C	26.4°C	26.5°C	26.5°C	26.5°C	5.0W	10.6V	PF
5	2025-07-04 18:27:03	-80.0°C	25.3°C	23.4°C	25.4°C	25.8°C	26.6°C	26.2°C	5.0W	10.5V	PF
6	2025-07-04 18:24:39	-80.0°C	25.2°C	23.3°C	25.4°C	25.7°C	26.4°C	26.4°C	5.0W	10.5V	PF
7	2025-07-04 18:22:32	-80.0°C	25.1°C	23.3°C	25.3°C	25.6°C	26.1°C	26.4°C	5.0W	10.5V	PF
8	2025-07-04 18:20:58	-80.0°C	25.0°C	23.3°C	25.3°C	25.5°C	25.7°C	26.8°C	5.0W	10.6V	PF
9	2025-07-04 18:19:50	-80.0°C	25.1°C	23.3°C	25.2°C	25.4°C	25.4°C	27.4°C	5.0W	9.7V	PF/BL
10	2025-07-03 17:37:03	-80.0°C	26.6°C	24.0°C	26.0°C	26.0°C	26.1°C	28.2°C	5.0W	0.5V	

(Figure 32)

2. During operation, there are two states: dual compressor and single compressor running alternately. When the compressor is running, the exhaust temperature will rise. By checking whether the exhaust temperature values of system A and system B are much higher than the ambient temperature, it can be judged whether the compressor is in operation.

3. When the temperature is abnormal, a high temperature alarm will occur: when the ambient temperature exceeds the default value, an ambient temperature high temperature alarm will be issued; when the condenser sensor temperature exceeds the default value, a condenser high temperature alarm will be issued.

4. In the logged-in state, you can click the “View details” button to view system operation information (set temperature, various sensor values, etc.), and select the corresponding time period to query and download relevant content.

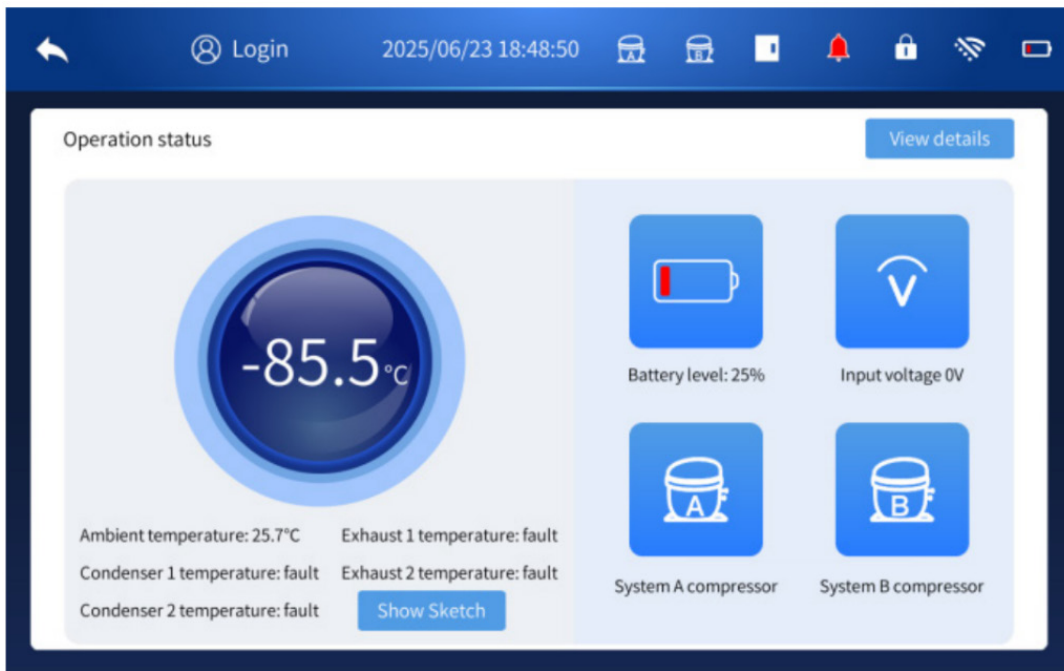

(Figure 33)

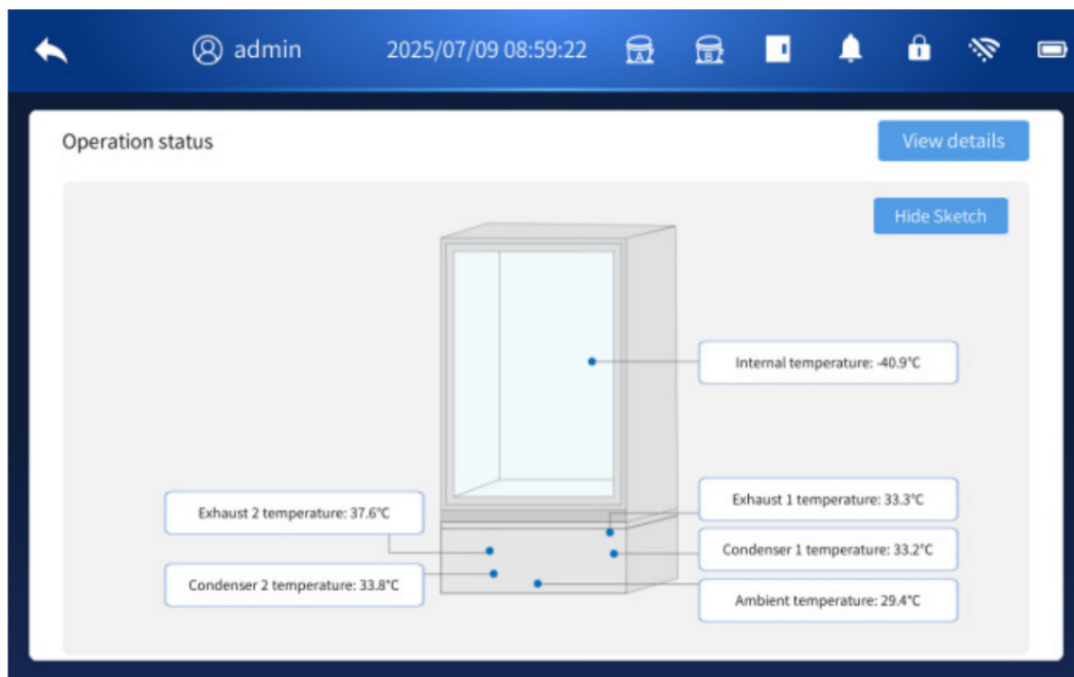

(Figure 34)

4.6 Device Information

- In the logged-in state, click Restart Software to restart the system.
- To update the system software, click Check for Updates, insert a USB flash drive, select the upgrade file, and click Upgrade to begin the update.

Notes:

A valid upgrade file is required, and software updates are normally not needed for everyday use. Updates are intended primarily for trained technicians.

The USB flash drive must be formatted to FAT32, have a capacity of 32GB or less, and contain no partitions.

For best compatibility, use well-known brands such as SanDisk, Kingston, Samsung, etc.

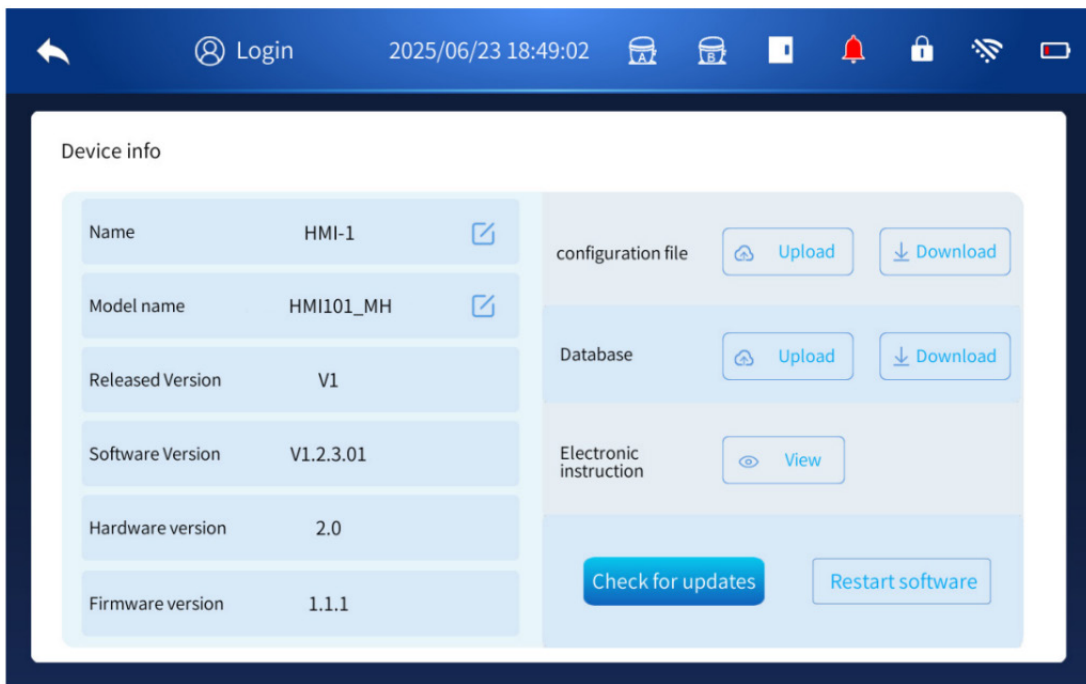

(Figure 35)

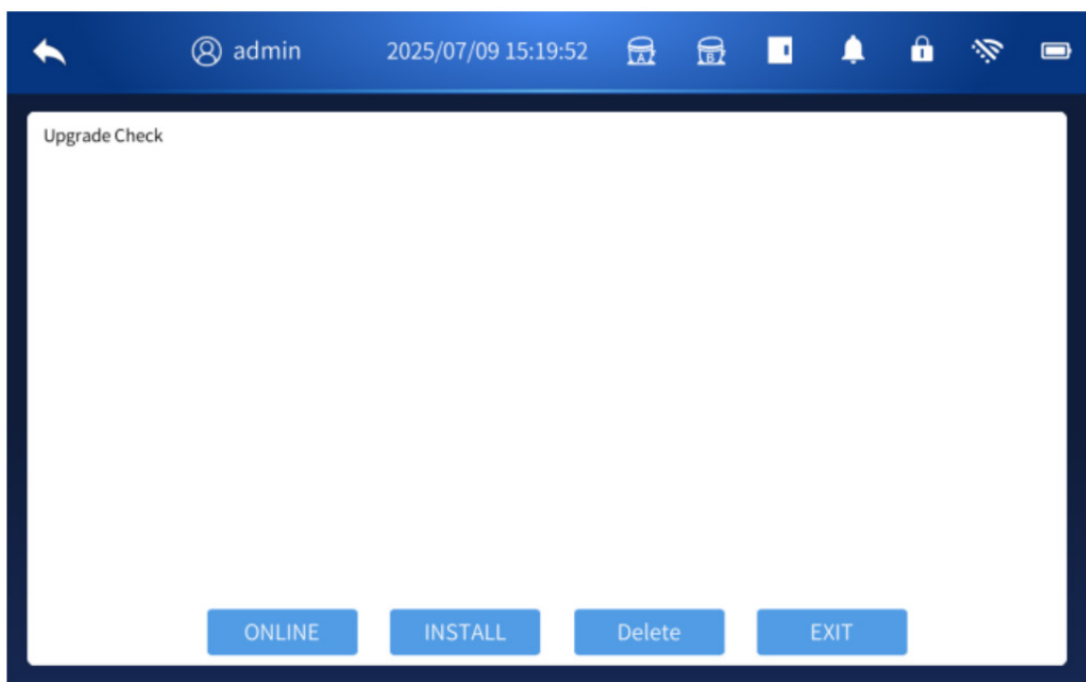

(Figure 36)

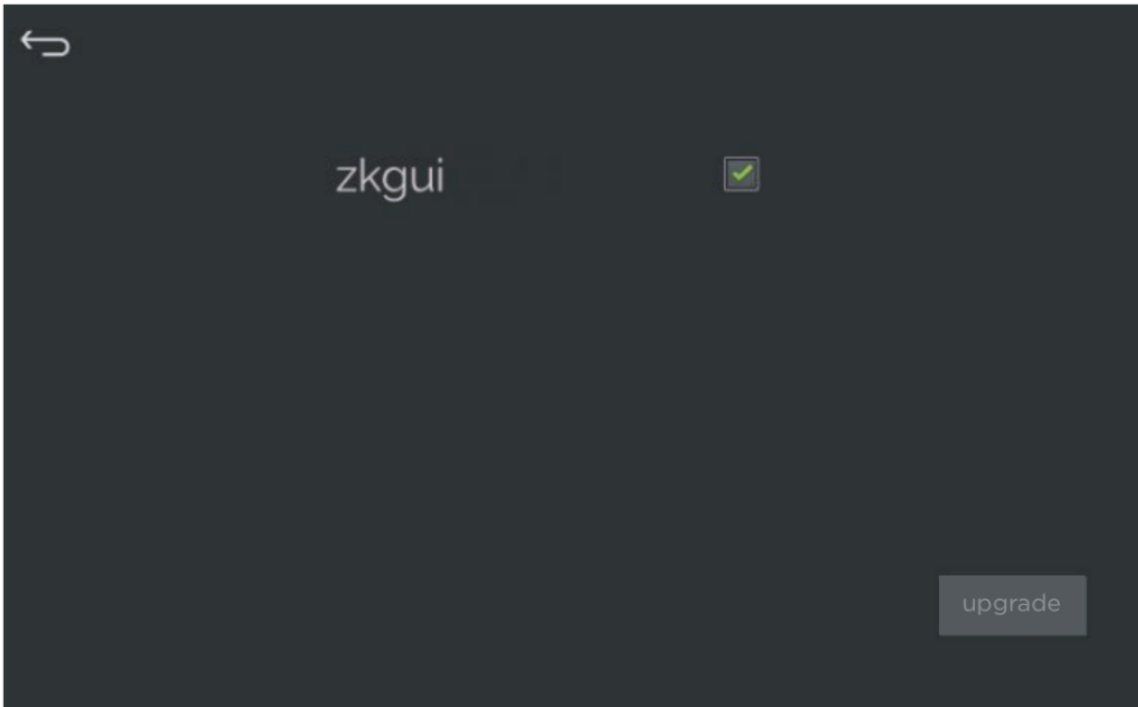

(Figure 37)

5. Other

5.1 State Indicator

The panel indicator shows the current operating status of the freezer:

- Green light: The refrigerator is operating normally after power-on.
- Red light: A fault has occurred.

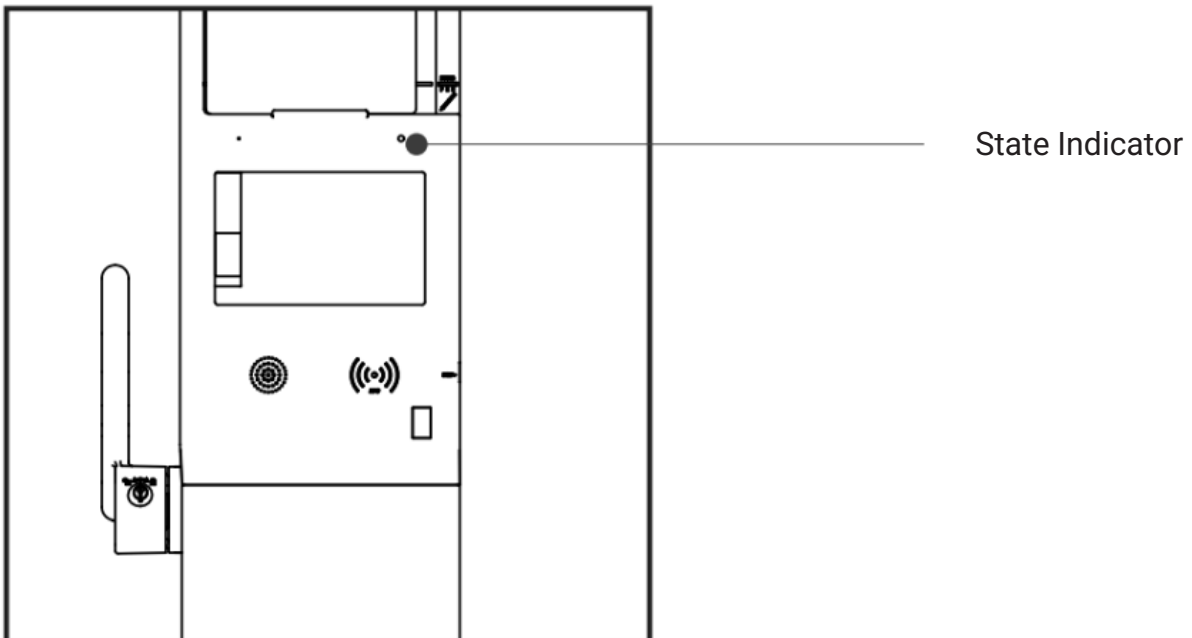

5.2 Balance Valve

When the interior of the biomedical freezer is at a very low temperature, a pressure difference can form between the inside and outside of the unit. This may make the door difficult to open.

To release this pressure, the balance valve automatically opens to allow ventilation and equalize the internal and external pressure, helping the door open more easily.

A small heating block is located behind the balance valve. This heater activates to prevent frost buildup around the valve opening. It is normal for the balance valve area to become warm during operation.

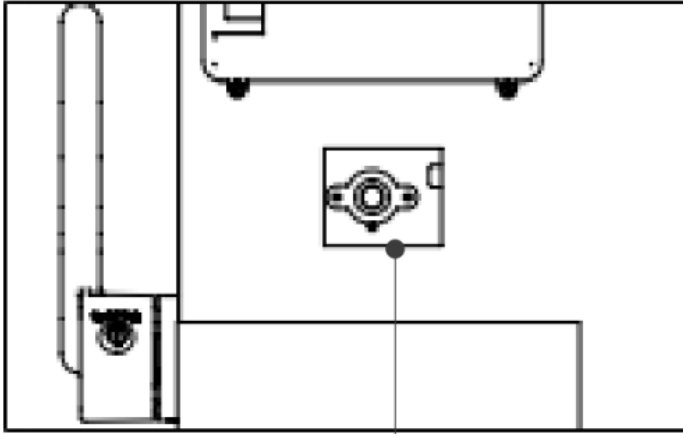

Balance valve

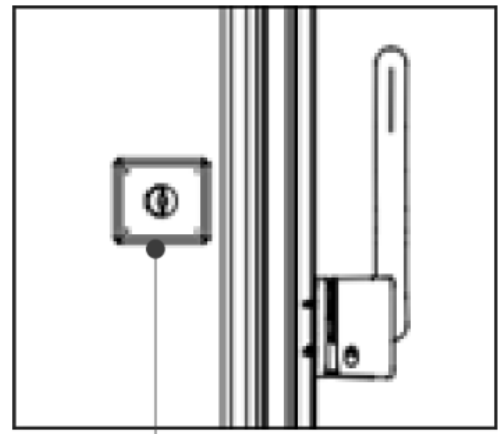

Balance valve heating block

Remote Alarm Function

This product includes a remote alarm output function. When an alarm occurs, the freezer can send an alarm signal through the remote alarm connector.

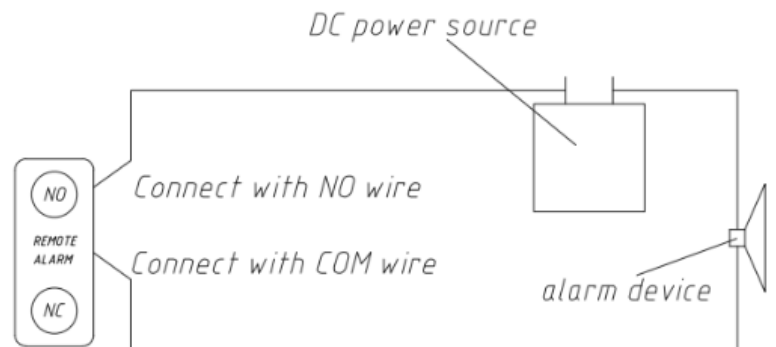
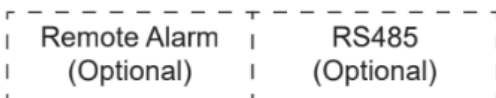
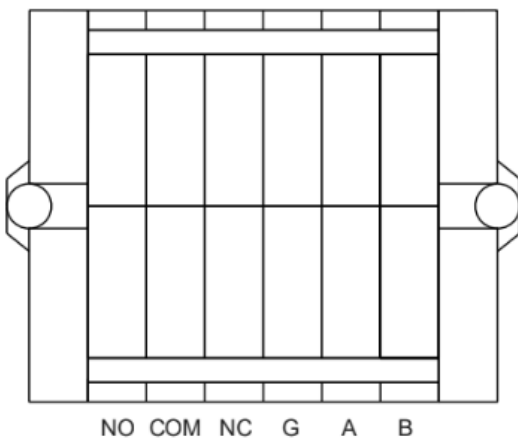

Connector Details

- Located in the lower-left area at the back of the unit.
- Maximum load capacity: DC 30V / 2A.
- Provides NO (Normally Open), COM (Common), and NC (Normally Closed) contacts.
- For optimal performance, the remote alarm cable should not exceed 9 feet in length.

Notes:

1. Users must install their own external alarm device and connect it to the remote alarm interface.
2. Pressing Mute on the display panel silences the audible alarm only; the remote alarm output remains active.
3. Any alarm condition will trigger the remote alarm output.

Remote Communication Function (RS-485)

This freezer can be equipped with an optional RS-485 remote communication interface. Through the RS-485 port, the freezer can transmit temperature data, alarm information, and other system signals to external monitoring software.

- The RS-485 connector is located behind the lower rear cover of the product.
- The connector includes RS485_A, RS485_B, and GND.
- **RS485_A** and **RS485_B** form a differential pair and should be wired using twisted-pair cable.

5V Power Output Function

The freezer includes an optional **5V power output** for external devices.

- The 5V output port is a USB socket located at the lower-left area at the back of the unit.
- Output capacity: **5V / 0.5A**.
- Do not exceed this output capacity when connecting external devices, as doing so may damage the control board.

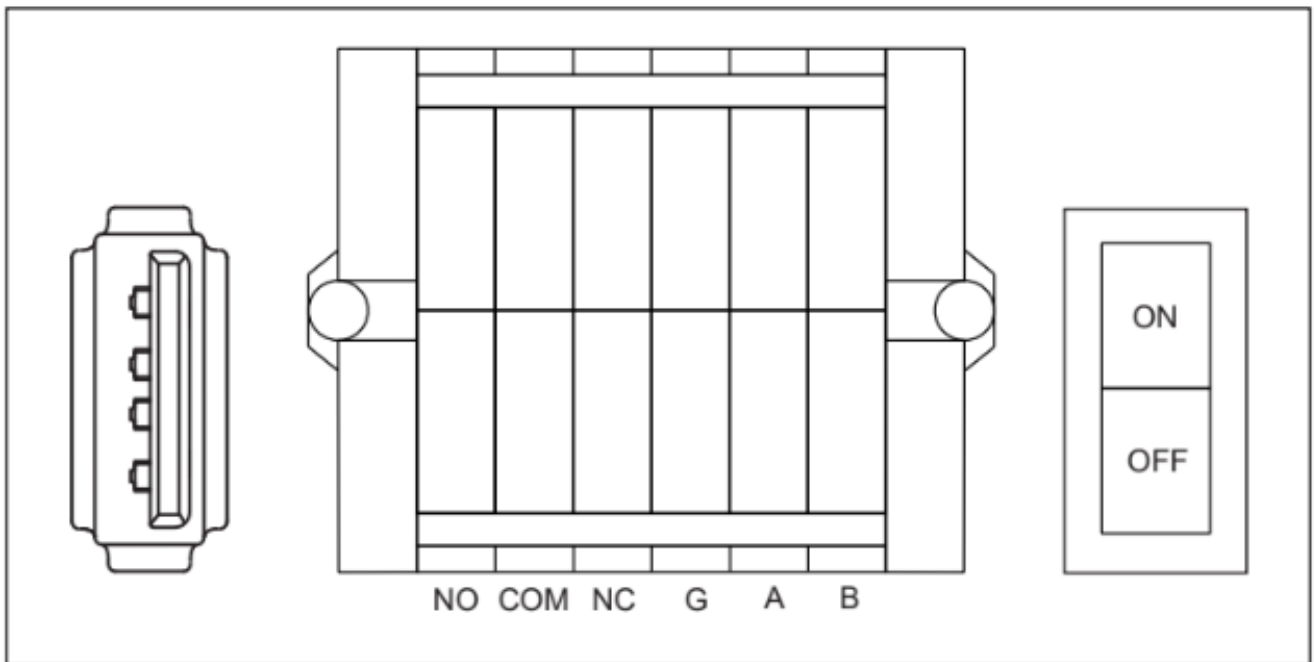

5V power output

Notes:

Due to product improvements or specific contract requirements, the actual functional configuration of your unit may differ slightly from what is described here. Always refer to the features of the physical product you received.

Maintenance

⚠ WARNING

When the interior of the biomedical freezer is at a low temperature, a pressure difference may form between the inside and outside of the unit, making the door difficult to open. The balance valve opens automatically to equalize pressure and allow easier door opening.

A small heater around the balance valve activates to prevent frost buildup, so it is normal for this area to become warm during operation.

⚠ CAUTION

- Do not splash water directly onto the freezer body. Moisture may reduce electrical insulation or cause metal parts to rust.
- Do not splash water directly onto the freezer body. Moisture may reduce electrical insulation or cause metal parts to rust.
- Do not place heavy objects on top of the unit, as this may cause deformation.

Clean This Product

- Wipe off light dust using a dry cloth.
- For internal cleaning, use a cloth soaked in mild neutral detergent. Remove detergent with a damp cloth and finish with a dry cloth.
- Do not pour water into the housing or chamber—water may damage electrical insulation and cause faults.
- The compressor and other mechanical parts are sealed and do not require lubrication.
- Clean the freezer once a month to maintain appearance and performance.
- Regular cleaning helps prevent frost buildup and keeps the condenser filter screen clear.

Cleaning the Condenser Filter Screen

1. Remove the front bottom hood and access the filter screen.
2. Wash the filter screen with clean water.
3. Clean any dust or debris on the condenser.
4. After the filter is completely dry, reinstall it and reattach the hood.
5. Clean the filter screen monthly under regular use.

Note: A blocked filter screen reduces cooling efficiency and may shorten the service life of the freezer.

Defrosting Inside the Biomedical Freezer

Excessive frost can impair cooling performance. Defrosting is recommended monthly, or at least every three months.

Defrosting Steps

- Remove stored items and place them in a suitable storage environment.
- Unplug the freezer or turn off the miniature circuit breaker.
- Open both the inner and outer doors to allow natural defrosting to occur.
- Wipe accumulated water from the bottom of the freezer with a dry cloth.
- After defrosting and cleaning, close the doors and restart the freezer.

- Once the unit has fully cooled, return the items to the freezer.

⚠ CAUTION

Do not use knives, screwdrivers, or any sharp tools to remove frost.

Replacement Cycle of Components

Part / Component	Suggested Replacement Cycle
Condenser fan (12V, 3.5W)	5 years

Equipment Out of Service

Out of Service:

If the freezer will not be used for an extended period:

- Disconnect the power supply.
- Clean the inside and outside surfaces with a soft, damp cloth and allow to dry completely.
- Close and seal the doors.
- Lock the unit to prevent children from entering the chamber and risking suffocation.

Scrap / Disposal

When the freezer reaches the end of its service life:

- Dispose of the unit through qualified professional recycling organizations in accordance with local regulations.
- Do not disassemble the unit yourself. Unauthorized dismantling is prohibited.
- Place scrapped equipment in a secure location away from children to avoid hazards.

Specification

Name	Low-temperature Freezer		
Model	KM-PHF-30CUL	KM-PHF-25CUL	KM-PHF-20CUL
Electrical Shock Protection Class	Class I		
Power Supply	100V-240V~/50/60Hz		
Compartment Temperature	-40°C~-86°C		
Refrigerant	Mixed Refrigerant		
Cooling Mode	Direct Cooling		
Volume (cu. ft.)	30	25	20
Rated Current	7.0A (at 240V) 14.0A (at 100V)	6.5A (at 240V) 14.0A (at 100V)	6.5A (at 240V) 14.0A (at 100V)
Operating Power	495W (at 240V) 850W (at 100V)	450W (at 240V) 720W (at 100V)	360W (at 240V) 550W (at 100V)
Weight	758 lbs	705 lbs	635 lbs
Product Dimensions (W * D * H)	46.26 × 39.17 × 77.95 in	40.55 × 39.17 × 77.95 in	34.84 × 39.17 × 77.95 in
Noise (sound pressure level)	46 dB	46 dB	46 dB
Shelf Weight Capacity	192 lbs	165 lbs	108 lbs

Description of Technical Parameters

The technical parameters in this table are measured under standard conditions. Specifications may change without prior notice due to product improvements or technical updates. The actual parameters for your unit are those shown on the nameplate attached to the unit.

Packing List

Name	Instructions for Use	Key (for Lock)	Defrosting Shovel	Spacer Bracket	Shelf	Shelf Clip
Quantity	1 copy	2 pcs.	1 pc.	2 pcs.	3 pcs.	15 pcs.

Note: Optional accessories, such as an external padlock or handle, may vary depending on the actual product configuration.

Electrical Schematic Diagram

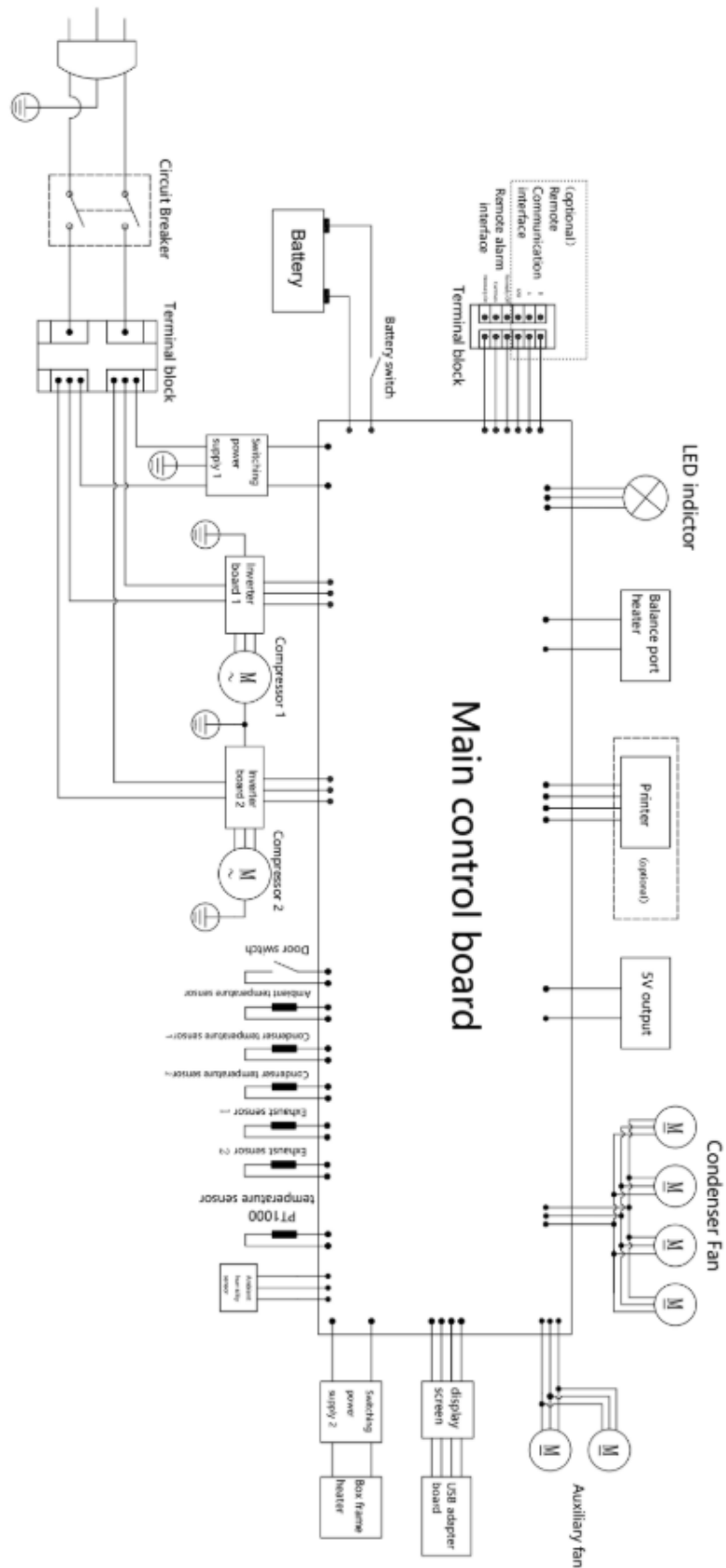

Note: Some models do not include a running capacitor or condenser fan. Please refer to the actual product.



Protection of the Environment

This symbol attached to the product means that it is an appliance whose disposal is subject to the directive on waste from electrical and electronic equipment (WEEE). This appliance may not in any way be treated as household waste and must be subject to a specific type of removal for this type of waste. Recycling and recovery systems are available in your area (waste removal) and by distributors. By taking your appliance at its end of life to a recycling facility, you will contribute to environmental conservation and prevent any harm to your health.

Troubleshooting

Any product may experience a fault during use. Please monitor the equipment regularly, and if you notice any abnormal operation, refer to the troubleshooting table below for guidance. If the issue cannot be resolved, contact our Customer Service Center promptly.

General Faults

Fault	Troubleshooting
The product does not work.	<ul style="list-style-type: none"> • Check whether the power circuit breaker is on. • Ensure the power voltage is not too low. • Verify the power switch is turned on. • Check whether the fuse is blown.
Poor cooling	<ul style="list-style-type: none"> • Check whether the ambient temperature is too high. • Ensure both inner and outer doors are tightly closed. • Verify that the air inlet is clean and unobstructed. • Inspect the condenser and filter screen for dirt or blockage. • Make sure the temperature is set correctly. • Confirm the product is not exposed to direct sunlight. • Ensure the unit is kept away from heat sources. • Check whether the rubber hole cover and insulation around the test-through testing holes are correctly installed.
Excessive noise	<ul style="list-style-type: none"> • Ensure the product is installed on a solid, level surface. • Check whether any external items are touching the housing. • Confirm that the unit's adjustable feet are properly leveled.

Alarm Faults

Fault	Troubleshooting
Door open alarm	Verify that the door is fully closed.
Power failure alarm	Check whether the power cord is unplugged or if the miniature circuit breaker is disconnected.
High ambient temperature alarm	Check whether the indoor temperature is too high.
High ambient temperature	Check whether the exhaust sensor is disconnected.
Exhaust sensor fault alarm	Check the battery voltage and ensure the system is powered on.
Condensation sensor fault alarm	Check whether the condensation sensor is disconnected.
Abnormal input voltage alarm	Check whether the input voltage is excessively high or low.
System A/B compressor fault alarm	Check for issues with the corresponding refrigeration system.
Communication fault alarm	Confirm that the communication cable is inserted correctly and verify whether the main control board, display, or communication board is damaged.



WARRANTY

LIMITED WARRANTY

KoolMore Supply Inc. extends a limited warranty to the original purchaser, guaranteeing that this KoolMore product is free from manufacturing defects in material or workmanship for one year from the date of purchase.

Should you discover any such defect within the warranty period, KoolMore Supply Inc. reserves the right to repair or replace the product without charge, or to cover the cost of replacement parts and repair labor needed to correct defects present at the time of purchase or resulting from regular usage, when the appliance has been installed, operated, and maintained as per the instructions provided.

At its sole discretion, KoolMore Supply Inc. may decide to replace the product. In such an event, your replacement appliance will carry the warranty for the remaining term of the original unit's warranty period.

This warranty is valid exclusively to the original purchaser of the product and only applicable within the United States. The warranty commences from the date of original consumer purchase. Proof of the original purchase date will be required to obtain service under this warranty.

Under this limited warranty, your sole and exclusive remedy will be product repair, as outlined above. All services must be provided by a KoolMore designated service company.

To claim warranty or request repair service:

Email support@koolmore.com. Please include your name, address, phone number, warranty repair request, and a copy of your proof of purchase receipt. Alternatively, visit koolmore.com and use the Contact Us page. A KoolMore customer service representative will promptly arrange service for your appliance.

We thank you for choosing KoolMore.

WARRANTY EXCLUSIONS

This limited warranty will not cover:

1. Failure of the product to perform during power failures or interruptions, or due to inadequate electrical service.
2. Damage incurred during transportation or handling.
3. Damage caused by accidents, vermin, lightning, winds, fire, floods, or acts of God.
4. Damage resulting from accidents, alterations, misuse, abuse, improper installation, repair, or maintenance. This includes using any external device that alters or converts the voltage or frequency of electricity.
5. Unauthorized product modifications, repairs by unauthorized centers, or use of non-approved replacement parts.
6. Abnormal cleaning and maintenance not aligned with the user's manual.
7. Use of incompatible accessories or components.
8. Any costs associated with repairs or replacements under these excluded circumstances shall be the responsibility of the consumer.

