

The following guide will give you the information on troubleshooting, common service issues, service procedures, service issues, and charging. **(The schematic can be downloaded from the user manuals available on our website. * NOTE YOU WILL NEED TO KNOW THE VOLTAGE & WHICH CONTROL THE UNIT HAS. THE CONTROL WILL HAVE ON THE FRONT WHICH VERSION IT IS. FDC4000, C-42, 4100, 1160)**

When we have a faulty compressor, we also change out the capillary tube assembly, You will find the capillary tube assembly behind the small backplate on the back of the unit.

Be sure the unit is at room temperature and recover all the refrigerant. No special recovery equipment is necessary. Once the refrigerant is recovered, and all the parts removed, flush the system thoroughly. We recommend Rx-11 flush.

Once this is accomplished, installation of the new parts may proceed. When completed, we charge the system with 300 PSI of dry Nitrogen and check the pressure readings for leaks no less than 24 hours. After 24 hours has passed and no leaks are present, evacuation of the system may proceed. We recommend a Micro reading of 50 mics but anything 200 mics or less should suffice. Charging the system may proceed after 12 hours of no vacuum leak. If you have any questions call or email the service department with the model and serial number of the unit you are working on.

Call or email the service department between
8:00 am & 4:30 pm E.S.T. Monday – Friday

Service Phone: (513) 326-2052

Email: service@so-low.com

Parts: parts@so-low.com

A) Service Procedure

- 1) In case of a compressor replacement, the capillary line assembly is **always** replaced.

- 2) A High stage rebuild includes the compressor and the capillary line assembly.
 - Flushing the system is only needed in case of a compressor burnout, or if oil is found in the system.

- 3) A Low-Stage rebuild includes the compressor, the capillary line assembly, and the oil separator.
 - The oil separator on units 3 years or younger does **not** need to be replaced unless in the case of compressor burnout, or if an oil restriction is present. Flushing the system in these cases is vital.



Service Hint: The capillary line assemblies are found behind the small back plate at the rear of the freezer. The drier for the Hi-Stage system is usually located next to the Hi-Stage compressor.

The preferred flushing agent that we use is **Rx11-flush**.

Note: The following information does **NOT** cover **ALL** service calls, just the most common.

B) CASCADE UNITS (-40°C to -85°C)

- 1) **Unit tripping breaker:** 90% of these are due to low voltage. The cause of which is usually undersized wire for the distance from the panel box to the unit.



Service Hint: After checking incoming voltage, check the voltage drop when **each** compressor starts. (Below 110 volts the amp draw starts to pick up).

- 2) **Unit not making -80°C:** If the unit is holding -50°C to -60°C, check the low stage compressor and see if it is cycling on the pressure control. If it is, then check the high stage thermocouples against the readings in the service manual. A simple addition of 1 to 3 oz. of R404A usually solves the problem. After 3 oz., the high stage capillary line assembly is probably restricted and needs to be replaced.
- 3) **Unit completely warmed up:** If the high stage is running, and the low stage is off, the low stage relay is usually at fault. **HOWEVER**, sometimes the pressure control is defective.



Service Hint: Eliminate the pressure control by jumping out the switch at the main circuit board (Control board). Refer to the schematic. (**The schematic can be downloaded from the user manuals available on our website.**)

- 4) **Unit not making temperature:** If both compressors are running, check the running pressures. If your charge lines are 2' or shorter, the refrigerant loss will not be significant.

- A high suction pressure and low head pressure are **usually** an indication of an oil restriction, but not always. In this case our policy is a low stage rebuild (**Refer to section A for more information**). Flushing the system before reassembly is vital.

- Low running pressures on both sides of the system is a clear indication of a leak. Shut the unit off and check the soaking pressures after 12 to 24 hours. Comparing these pressures to the service manual is the usual procedure.

C) SINGLE STAGE UNITS (0°C to -40°C)

1) Unit is not cooling, and compressor is off:

- Usually a faulty compressor control relay (Refer to schematic. **The schematic can be downloaded from the user manuals section on our website.**)
- Rarely a temperature control but may be defective.

2) Unit warming and compressor is running:

- Checking running pressures. There could be a leak or restriction.

(The following information is addition to what has been mentioned)

1) Low-Stage Systems Cycling on Pressure Control.

- High Stage system failure due to leak or restriction.
- Low Stage Restriction.



Service Hint: It happens far too often that the condenser is not cleaned regularly.

2) Unit warming up due to oil restriction in Low Stage:



Service Hint: Many times, an oil restriction is caused by the customer overloading the unit, causing it to run (sometimes for days) before reaching setpoint temperature. In this case, a popular quick fix of shutting the unit off, defrosting the unit overnight with the door or lid open and restarting the unit the following morning will sometimes alleviate this condition. Reload product in stages once the unit is back down to temperature.

3) Compressor Failure: This can happen in **any** freezer, new or old. Refer to section A for procedures.

REFRIGERATION ISSUE IDENTIFICATION

Situation 1) High Head Pressure

Check if the Low Stage continuously runs; or if you hear the Low Stage start and turn off, and then restart in a few minutes. If so; your system is going off on High Head Pressure.

- If you have a discharge gauge on the valve above the low stage compressor, you can see this happen. Your pressure will go up to 300 lbs. and your Low Stage compressor will shut off. This in turn is due to the first stage (High Stage – 404A system) not keeping the Low Stage condensed down.

Solution

- Check the suction on the High Stage system via the process tube.
- Your suction should be about 6 Lbs. If not; try adding 2 or 3 ounces of 404A.
- If adding 404A does not keep the Low Stage system running, then replace the cap tube and filter drier on the 404A High Stage system.

Situation 2) Low Stage Compressor is Inefficient

The Low Stage compressor may be inefficient due to weak valves.

- If the Low Stage compressor's suction is 5 lbs or more, the possible cause is the valves going out of the compressor.

Solution

- The evaporator should first be flushed out.
- After the evaporator is flushed, the Low Stage compressor, cap tube, drier, oil separator should be replaced.

Situation 3) Low Stage System Oil Logged

The Low Stage system may be oil logged.

Solution

- The evaporator should first be flushed out.
- After the evaporator is flushed, the Low Stage cap tube, drier, and oil separator should be replaced.

The following Type “T” thermocouple readings are taken with a plug-in type digital thermometer. We use one made by Omega Corp. Model NO. HH911T (Phone # (1-888-826-6342) We use Type T thermocouples.

You will find these thermocouples rolled up and tucked next to where the refrigeration lines enter the compressor area.

High Stage	In (without L/S) : -40°F
	Out (without L/S) : -42°F
	In (with L/S) : -33°F
	Out (with L/S) : -36°F

When the Lo-Stage (L/S) starts, typically, the H/S out will warm to the Teens (-13°C to -18°C) or around freezing in °F. Any warmer than those temperatures, and the L/S has probably cycled off on the pressure control. This would indicate a deficient charge or restriction on the High-Stage system.

After about 2 hours running time, the Low-Stage (L/S) system should have reached its maximum temperature on the L/S in, of about -130°F (-93°C). The L/S out will be determined by the present freezer temperature (ie. Control reads -50°C L/S in: -93°C, L/S out: -30°C). The only time where these temperature control readings would be close if when the control is set for -100°C (-150°F) and the control reads -90°C or better. Then the temperature control reading should be L/S in: -93°C (-130°F) L/S out: -95°C (-135°F) (approximately).

Ultra-Low Temperature Freezers

Refrigeration System Type: Cascade

*Compressors: **Tecumseh AJB Series**
115 Volts, 60 Cycle, 1 Phase
208/220/230 Volts, 60 Cycle, 1 Phase
200/220/230 Volts, 50 Cycle, 1 Phase*

*Refrigerants: High Stage System: R404A
Low Stage System: R508B*

HIGH STAGE SYSTEM: R404A

Recharging the high stage system: If the high stage system has been evacuated and is being recharged, then weigh in the appropriate amount of [R404A](#).

Chest Models:

C85-3, PR120-3 - 12 oz.
C85-5, PR120-5 - 16 oz.
C85-9, PR120-9 - 17 oz.
C85-12, PR120-12 - 19 oz.
C85-14, PR120-14 - 19 oz.
C85-17, PR120-17 - 19 oz.
C85-22, SE22-120 - 23 oz.
C80-27, SE27-110 - 23 oz.

Upright Models:

U85-13, A13-120 - 23 oz.
U85-18, A18-120 - 24 oz.
U85-22, A21-120 - 24 oz.
U85-25, A25-120 - 25 oz.
U80-30, A30-110 - 26 oz.

LOW STAGE SYSTEM: TECUMSEH

Recharging the low stage system:

Do not turn the low stage system (refrigeration on-off) switch "on" unless the high stage system is operating.

If the low stage system has been evacuated and is being recharged, have the freezer unplugged and warmed to room temperature if possible before proceeding.

Low Stage Additive:

Note: If you purchased the cylinder of R508B from So-Low, the additive is already mixed in with the R-508B and this step can be skipped.

While the low stage system is in a vacuum:

- 1) Add R-170 (Ethane - chemically pure or instrument grade) from vacuum to 25 psi.

or if R-170 is not available use R-290 - see #2. (R-170 is the preferred additive)

- 2) Add R-290 (instrument grade propane) from vacuum to 15 psi.

Charging with R-508B:

After the additive has been added to the low stage system, connect R-508B tank directly to the suction process tube. Add R508B until discharge gauge reads 135 psi. The pressure will settle at 130 psi after several minutes. Plug the freezer into an appropriate power supply.

The high stage system will start immediately, the low stage system will start after the timer engages. Adjust pressures only if unit does not reach set point. The operating pressures are provided on the following sheet.

ULTRA LOW OPERATING PRESSURE CHART

“N”

HIGH STAGE:

Compressor: ½ HP Tecumseh
Soak Pressure: 140
Refrigerant: R-404A

LOW STAGE:

Compressor: ½ HP Tecumseh
Soak Pressure: 130
Refrigerant: R-170
R-508B

AMBIENT +75°F

CABINET TEMPERATURE	21°C 70°F	0°C 32°F	-40°C -40°F	-70°C -94°F	-85°C -120°F	MAX (-92°C)
HIGH STAGE PSI HEAD PRESSURE SUCTION PRESSURE 134A / HP62	230 7	240 9	240 6 ½	230 6	230 6	210 4
LOW STAGE PSI HEAD PRESSURE SUCTION PRESSURE R508B	180 1"	185 1 ½"	170 1"	160 3"	150 3"	150 4"

*NOTE: THESE PRESSURES ARE ONLY APPROXIMATES, BASED ON A 75°F AMBIENT.

Refrigeration System Type: Cascade

*Compressors: **Embraco FFI Series***

115 Volts, 60 Cycle, 1 Phase

Refrigerants: High Stage System: R404A

Low Stage System: R508B

HIGH STAGE SYSTEM: R404A

Recharging the high stage system: If the high stage system has been evacuated and is being recharged, then weigh in the appropriate amount of [R404A](#)

Chest Models:

C85-3, PR120-3 - 15 oz.
C85-5, PR120-5 - 16.5 oz.
C85-7, PR120-7 - 16 oz.
C85-9, PR120-9 - 15 oz.
C85-12, PR120-12 - 15 oz.

Upright Models:

U85-7 - 17 oz.
U85-11 - 17 oz.
U85-13 - 17 oz.

LOW STAGE SYSTEM: EMBRACO

Recharging the low stage system:

Do not turn the low stage system (refrigeration on-off) switch "on" unless the high stage system is operating. If the low stage system has been evacuated and is being recharged, have the freezer unplugged and warmed to room temperature if possible before proceeding.

Low Stage Additive:

Note: If you purchased the cylinder of R508B from So-Low, the additive is already mixed in with the R-508B and this step can be skipped.

While the low stage system is in a vacuum:

- 1) Add R-170 (Ethane - chemically pure or instrument grade) from vacuum to 20 psi.

or if R-170 is not available use R-290 - see #2. (R-170 is the preferred additive)

- 2) Add R-290 (instrument grade propane) from vacuum to 15 psi.

B) Charging with R-508B:

After the additive has been added to the low stage system, connect R-508B tank directly to the suction process tube. Add R508B until discharge gauge reads 145 psi. The pressure will settle at 140 psi after several minutes. Plug the freezer into an appropriate power supply. The high stage system will start immediately, the low stage system will start after the timer engages.

Adjust pressures only if unit does not reach set point. The operating pressures are provided on the following sheet.

ULTRA LOW OPERATING PRESSURE CHART

“N”

HIGH STAGE:

Compressor: 1/3 HP Embraco
Soak Pressure: 120
Refrigerant: R-404A

LOW STAGE:

Compressor: 1/3 HP Embraco
Soak Pressure: 150
Refrigerant: R-170
R-508B

AMBIENT +75°F

CABINET TEMPERATURE	21°C 70°F	0°C 32°F	-40°C -40°F	-70°C -94°F	-85°C -120°F	MAX (-92°C)
HIGH STAGE PSI HEAD PRESSURE SUCTION PRESSURE 134A / HP62	180/200 2-4 psi	180/200 2-4 psi	180/200 1-3 psi	170/190 1-3 psi	170/190 1-2"	170/190 1-2"
LOW STAGE PSI HEAD PRESSURE SUCTION PRESSURE R508B	200/220 3-5 psi	200/220 3-5 psi	190/210 3-5 psi	180/200 2-4 psi	170/185 1-3 psi	170/185 0-5"

*NOTE: THESE PRESSURES ARE ONLY APPROXIMATES, BASED ON A 75°F AMBIENT.

Refrigeration System Type: Cascade

*Compressors: **Danfoss SC15 Series***

115 Volts, 60 Cycle, 1 Phase

Refrigerants: High Stage System: R404A

Low Stage System: R508B

HIGH STAGE SYSTEM: R404A

Recharging the high stage system: If the high stage system has been evacuated and is being recharged, then weigh in the appropriate amount of [R404A](#)

Chest Models:

C85-3, PR120-3 - 15 oz.
C85-5, PR120-5 - 16.5 oz.
C85-9, PR120-9 - 18 oz.

Upright Models:

U85-13 - 24 oz.

LOW STAGE SYSTEM: DANFOSS

Recharging the low stage system: Do not turn the low stage system (refrigeration on-off) switch “on” unless the high stage system is operating. If the low stage system has been evacuated and is being recharged, have the freezer unplugged and warmed to room temperature if possible before proceeding.

Low Stage Additive:

Note: If you purchased the cylinder of R508B from So-Low, the additive is already mixed in with the R-508B and this step can be skipped.

While the low stage system is in a vacuum:

- 1) Add R-170 (Ethane - chemically pure or instrument grade) from vacuum to 20 psi.

or if R-170 is not available use R-290 - see #2. (R-170 is the preferred additive)

- 2) Add R-290 (instrument grade propane) from vacuum to 15 psi.

B) Charging with R-508B:

After the additive has been added to the low stage system, connect R-508B tank directly to the suction process tube. Add R508B until discharge gauge reads 160 psi. The pressure will settle at 155 psi after several minutes. Plug the freezer into an appropriate power supply. The high stage system will start immediately, the low stage system will start after the timer engages. Adjust pressures only if unit does not reach set point. The operating pressures are provided on the following sheet.

ULTRA LOW OPERATING PRESSURE CHART

“N”

HIGH STAGE:

Compressor: 1/3 HP Danfoss
Soak Pressure: 120
Refrigerant: R-404A

LOW STAGE:

Compressor: 1/3 HP Danfoss
Soak Pressure: 150
Refrigerant: R-170
R-508B

AMBIENT +75°F

CABINET TEMPERATURE	21°C 70°F	0°C 32°F	-40°C -40°F	-70°C -94°F	-85°C -120°F	MAX (-92°C)
HIGH STAGE PSI HEAD PRESSURE SUCTION PRESSURE 134A / HP62	180/200 2-4 psi	180/200 2-4 psi	180/200 1-3 psi	170/190 1-3 psi	170/190 1-2"	170/190 1-2"
LOW STAGE PSI HEAD PRESSURE SUCTION PRESSURE R508B	200/220 3-5 psi	200/220 3-5 psi	190/210 3-5 psi	180/200 2-4 psi	170/185 1-3 psi	170/185 0-5"

*NOTE: THESE PRESSURES ARE ONLY APPROXIMATES, BASED ON A 75°F AMBIENT.

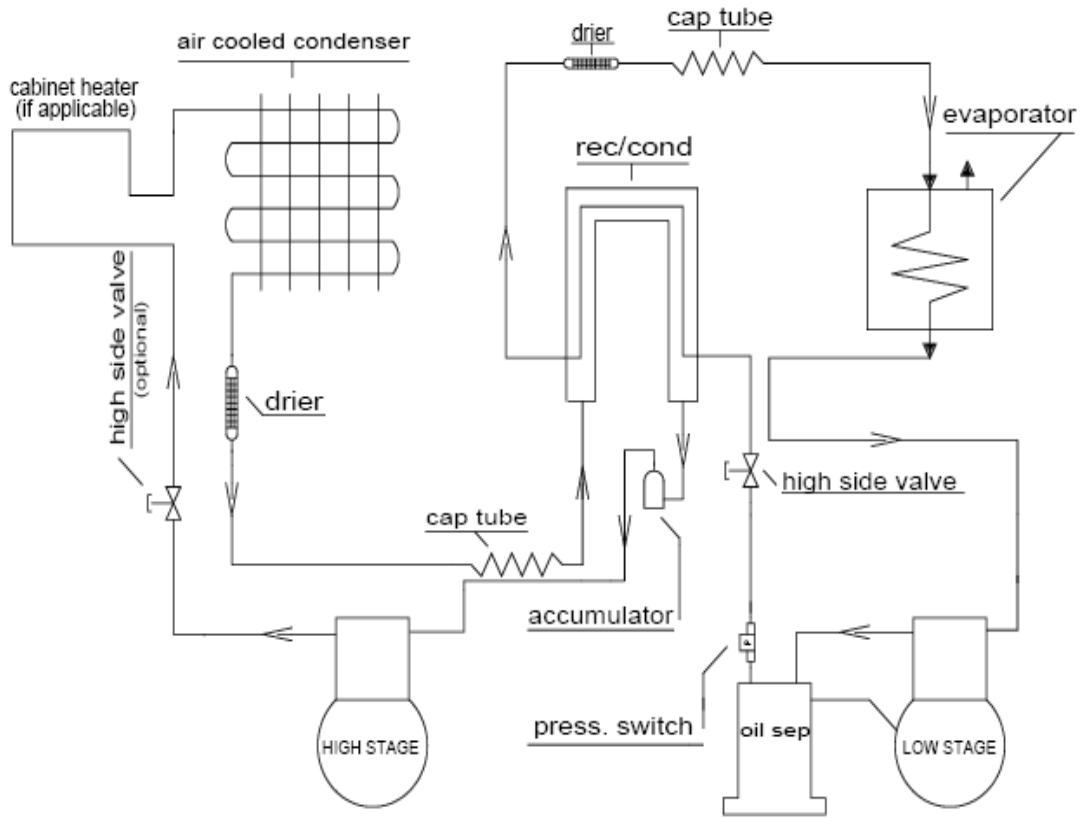

REFRIG. FLOW CHART