



OPERATING INSTRUCTIONS AND SERVICE MANUAL



Alō Treatment model shown with wingback and optional Tuxedo styling.

**The Classic, The Ascent, Ascent II,
Alō Treatment, & Alō Recovery**

MEDICAL RECLINER/TRANSPORTER

CONTENTS

<u>ITEM</u>	<u>PAGE</u>
Contents	1-2
In-service information	3
Welcome	4
Special notes	4
Chair capacity information	5
Standard recliners	5
XL recliners	5
Chair electrical specifications	6
Average measured maximum temperatures	6
Heat or heat/massage only	6
Power recline only	6
Power recline + heat or heat/massage	6
Battery specifications	7
Replacement battery	7
Double-insulated products (heat/massage power supply)	7
Disposal of equipment and accessories	7
Technical description	7
Receiving new chairs	8-9
New chair inspection	8
To report damage	8
Return authorization	9
Storage	9
In-service procedures	10
General operating instructions	11
For safe recliner operation	11
Manual recliner operating instructions	12-16
Champion recliner operation one-pager	12
Chair positions (upright, TV, and full recline)	13-14
To move from upright to the TV position	13
To move from TV position to full recline position	13
To return to the TV position	13
To return to a full upright position from TV position	14
Trendelenburg operation	14-16
To actuate the Trendelenburg option	14
To return from a Trendelenburg position	14
Actuation of the recline and Trendelenburg device by staff	15
Setting the Trendelenburg feature one-pager	16
Power recliner operating instructions	17-21
Special notes	17
General set up	18-19
Handset operation	20
Trendelenburg operation	21
To actuate the Trendelenburg option	21
To return from a Trendelenburg position	21
Power recliner connections	22
Power connections	22

CONTENTS (continued)

ITEM	PAGE
Remove cables	22
Install cables	22
Heat & Heat/Massage operation	23-25
General Information	23-24
Heat & heat/massage operation	25
Troubleshooting	25
Operation of the swing-away arms (if equipped)	26
Operation of foot tray (if equipped)	27
Options and accessories	28-31
Options	28
Central locking caster option	28
Trendelenburg option	28
TV bracket	28
Accessories	28
Fold away side tables	28
Cushion wedge	28
Head pillow/lumbar support	29
IV pole	29
IV pole bracket	29
IV pole base	29
Dual remote controls	29
Use of IV pole	30
Stand-alone and integrated USB	31
USB operation	31
USB charger port general cleaning	31
USB power connections	31
General maintenance and care	32-38
General information	32-33
Use of quick release seat feature	34-35
Chairs with heat or heat/massage	36
General cleaning precautions	37
General cleaning - upholstery	38
Stain removal	38
General cleaning - plastic table tops	38
General infection control	38
Warranty procedure	39
File a warranty claim	39
Warranty does not apply if	39
Service information	40
Determining the problem	40
Serial number	40



In-Service Information

It is very important to Champion that our customers review all the materials in the in-service package they receive.

By reviewing the in-service materials provided, you increase the useful life of the products by helping to prevent their improper use, which may lead to premature damage and wear. You are also helping to validate your warranty, as warranties cover material and workmanship failures, not misuse or abuse. Use these in-service tools for new employees and as a “refresher” for current employees.

The following resources are available for you to assist your staff and patients in operating the chairs properly.



Field Sales Reps
In House Sales Reps
Network of Service Technicians
In House Service Team

Note: The information contained in this document is subject to change without notice.

WELCOME

Champion Healthcare Solutions would like to thank you for selecting our products. We take great care of making certain that our products leave the factory in a flawless condition. Our products are properly packaged to arrive in that same condition.

SPECIAL NOTES

 **WARNING**  **CAUTION** These terms refer to actions that may result in injury to your patient or staff member and/or damage to your product. Damage caused by improper operation of your chair is not covered by your warranty.

 **WARNING: Caregivers or others operating the product or moving the occupant must be aware of the location of the patient's hands and feet. Caregivers must confirm that the occupant's extremities are safely located before moving the chair from position to position, adjusting the position of the chair or moving the patient from the chair.**

 **WARNING: Place chair in a fully upright position or a fully reclined position when cleaning or maintaining your chair. Your recliner has moving parts that create pinch points. This chair moves easily without a patient in the chair and may create pinch points when not in these positions.**

 **WARNING: This recliner is designed to meet the needs of a wide range of patients. Some patients, due to their unique medical condition, may need assistance as they sit down or rise from a seated position. It is the responsibility of the care provider to assess these needs and provide assistance to frail, weak, or otherwise unsteady patients. Failure to follow these instructions can result in patient falls with potentially serious injury resulting.**

Note: The information contained in this document is subject to change without notice.

CHAIR CAPACITY INFORMATION

Standard Recliners

59 series	(Classic Fixed Manual)	300 lbs.
59P series	(Classic Fixed Power)	300 lbs.
61 series	(Alo Treatment Straightback Manual)	300 lbs.
61P series	(Alo Treatment Straightback Power)	300 lbs.
63 series	(Alo Treatment Wingback Manual)	300 lbs.
63P series	(Alo Treatment Wingback Power)	300 lbs.
61L series	(Alo Recovery Straightback Manual)	300 lbs.
61PL series	(Alo Recovery Straightback Power)	300 lbs.
63L series	(Alo Recovery Wingback Manual)	300 lbs.
63PL series	(Alo Recovery Wingback Power)	300 lbs.
65 series	(Ascent Manual)	300 lbs.
65P series	(Ascent Power)	300 lbs.
67 series	(Ascent II Manual)	300 lbs.
67P series	(Ascent II Power)	300 lbs.
85 series	(Classic Swing Manual)	300 lbs.
85P series	(Classic Swing Power)	300 lbs.

XL Recliners

58 series	(Classic XL Fixed Manual)	500 lbs.
58P series	(Classic XL Fixed Power)	500 lbs.
62 series	(Alo Treatment XL Straightback Manual)	500 lbs.
62P series	(Alo Treatment XL Straightback Power)	500 lbs.
64 series	(Alo Treatment XL Wingback Manual)	500 lbs.
64P series	(Alo Treatment XL Wingback Power)	500 lbs.
62L series	(Alo Recovery XL Straightback Manual)	500 lbs.
62PL series	(Alo Recovery XL Straightback Power)	500 lbs.
64L series	(Alo Recovery XL Wingback Manual)	500 lbs.
64PL series	(Alo Recovery XL Wingback Power)	500 lbs.
66 series	(Ascent XL Manual)	500 lbs.
66P series	(Ascent XL Power)	500 lbs.
68 series	(Ascent II XL Manual)	500 lbs.
68P series	(Ascent II XL Power)	500 lbs.
86 series	(Classic XL Swing Manual)	500 lbs.
86P series	(Classic XL Swing Power)	500 lbs.

CHAIR ELECTRICAL SPECIFICATIONS

All chairs with heat are built to properly handle the specified load for that model chair. The heater option does not change the size or load capability of that model.

Average Measured Maximum Temperatures

LOW	98 °F
MEDIUM	102 °F
HIGH	105 °F

Heat Or Heat/Massage Only

Electrical Requirements:	AC Power Supply: 100-240 VAC, 50-60 Hz
Rated Current Input:	Max. 1.0 Amps
Power Output:	12VDC, 3.5 A, 42 W

Power Recline Only

Electrical Requirements:	AC Power Supply: 120 VAC, 60 Hertz		
Rated Current Input:	Max. 2.7 Amps		
Power Output:	24VDC (Power recline) 5VDC (Standalone USB)		
Ambient Temperature:	+41 ° to +104 ° F (+5 ° to +40 ° C)		
Duty Cycle:	10%, Max. 2 min./18min.		
Protection Class:	IP Rating:	Class II	IP66
Battery Duration (approx. times):	Backup battery system to remain plugged in. Approx. 15 recline cycles of the chair from battery.		
Battery Recharge Time:	4 Hours, Storage 10 Hours every 6 months Running battery to low power will cause damage.		

Power Recline + Heat or Heat/Massage

Electrical Requirements:	AC Power Supply: 120 VAC, 60 Hertz		
Rated Current Input:	Max. 3.7 Amps		
Power Output:	12VDC (Heat/Massage with or without integrated USB) 24VDC (Power recline)		
Ambient Temperature:	+41 ° to +104 ° F (+5 ° to +40 ° C)		
Duty Cycle (Power recline):	10%, Max. 2 min./18min.		
IEC Protection Class:	Class II (Heat/Massage)	Class I (Power Recline)	
Battery Duration (approx. times):	Backup battery system to remain plugged in. Approx. 15 recline cycles of the chair from battery.		
Battery Recharge Time:	4 Hours, Storage 10 Hours every 6 months Running battery to low power will cause damage.		

BATTERY SPECIFICATIONS

Battery Type:	Lead Acid
Rated Capacity:	1.2Ah, 24V
Charging Current:	Max 0.3A



WARNING: DO NOT open the case of the battery. Doing so may be hazardous.

Replacement Battery

For replacement a replacement battery, please contact Champion's Customer Experience at 800-237-3377.

Double-Insulated Products (Heat/Massage power supply)

In a double-insulated product, two systems of insulation are provided instead of grounding. No means of grounding is provided on a double-insulated product, nor is a means for grounding to be added to the product. Servicing a double-insulated product requires extreme care and knowledge of the system and is to be done only by qualified service personnel. Replacement parts for double-insulated products must be identical to the parts they replace. A double-insulated product is marked with the words "DOUBLE INSULATION" or "DOUBLE INSULATED". The symbol () is also able to be used to identify a double insulated product.

Disposal of Equipment and Accessories

Follow local governing ordinances and recycling plans regarding disposal of device components. **DO NOT** dispose of the battery packs in household waste.



DO NOT dispose of
in household waste



Technical Description

The Champion Power Recliners with Heat and Massage are to be used by occupants and caregivers to assist in occupant positioning during treatment. Champion Power Recliners also increase the range of positioning over manual recliners. The Heat and Massage systems are occupant comfort features.

The Champion Power Recliner system uses a linear actuator to drive the recline mechanism inside the chair. The Champion Power Recliner can be positioned from full upright to full recline with the use of the handset. The Trendelenburg function (optional) is not controlled by the power function.

The Champion Power Recliners with Heat and Massage are capable of operation by the occupant or caregivers. Device standard power options include an AC to DC switching power supply operating from AC power outlet (120VAC/60 Hertz nominal) and a supplemental rechargeable battery.

RECEIVING NEW CHAIRS



CAUTION: New chair inspection must be done by someone who understands the instruction pages. Improper operation of the chair may damage the chair and void your warranty.

New chair inspection

1. Remove all packing material including foam wrap and poly bag. If desired, the bag may be replaced after examination.
2. Examine chair surfaces for damage.
3. If applicable, uncoil the power cord from the back of your chair and plug it into the proper wall outlet.
4. Operate all chair functions and options. This includes tables, casters, and battery as well as chair positions. Do this immediately upon receipt of your chairs.



WARNING: The power cord must be plugged into a properly grounded outlet and must not be modified in any way. If the three (3) blade plug does not fit your outlet, have one installed that meets your local codes by an electrician. Consult an electrician if you are unsure that the outlets are properly grounded. DO NOT use a three (3) blade plug to a two (2) blade adapter.



CAUTION: Before plugging chair into wall outlet, it should be checked for condensation on the electrical components and dried if necessary. The chair should reach room temperature prior to plugging it in.



CAUTION: To maintain optimal performance of the battery pack it must be plugged in at all times unless the occupant is in transport. If the chair will be stored for an extended period of time, the battery must be charged a minimum of ten (10) hours per six (6) months.

To report damage

1. If the freight carrier is still at your location (it is your right to hold the freight carrier while you thoroughly inspect your delivery), note any damage on the bill of lading. Take pictures if possible. Be sure to keep shipping cartons, pallets and other shipping materials to prove damage to the freight carrier. It is also important to save an undamaged carton and pallet in case the chair must be returned to the factory.
2. Call Champion's Customer Experience immediately to report the damage: 800-237-3377.
3. All claims must be filed by the consignee and reported to Champion Healthcare Solutions within 3 days of receipt of the shipment.

RECEIVING NEW CHAIRS (continued)

Return authorization

1. Champion customer experience must authorize all returns. Champion customer experience will issue a return authorization number by email. The customer does have the right to refuse any damaged chair from the carrier at the time of delivery.
2. All returns **MUST** be sent prepaid by the sender with the exception of provable shipping damage.

Storage

1. Cover chair and store in a dry area.
2. **DO NOT** place objects on top of the chair that may damage the vinyl.

IN-SERVICE PROCEDURES

Before chairs are put into service, all personnel should review this manual.

In the belief that an actual demonstration of the product is more effective than written instructions, an on-site in-service by a Champion representative may be available depending upon the delivery circumstances.

Pay special attention to the hang tag attached to the handle, or chair back. This identifies actions that may damage your product. It is extremely important that chairs are operated properly and used in the way they were designed.

Certain improper methods of operating the chair can damage the chair and void the warranty.

 **WARNING: Place chair in a fully upright position or a fully reclined position when cleaning or maintaining your chair. Your chair has moving parts that create pinch points. This chair moves easily without a patient in the chair and may create pinch points when not in these positions.**

 **WARNING: NEVER place your hands near or on a recliner mechanism when it is in motion. NEVER clean or maintain a chair when an occupant is in the chair. The occupant is able to control the chair's position and may move the chair position unexpectedly, creating pinch points.**

 **WARNING: Keep hands, feet and legs clear of the recline mechanism.**

 **WARNING: When closing the leg rest by hand, make sure your hand is placed on the top upholstered surface of the footboard only not under the edges as this product has moving parts that may create pinch points. Keep all body parts clear of the recline mechanism, latches, leg rest and other moving parts**

 **CAUTION: DO NOT overload chair. Observe the specified maximum weight capacity for the chair model that you have selected.**

 **CAUTION: DO NOT attempt to force the chair into position; permanent damage may result. The chair works with normal effort when operated properly.**

GENERAL OPERATING INSTRUCTIONS

For Safe Recliner Operation

1. **Always** set the caster brakes before allowing your patient to get in or out of the chair. Release the caster brakes **ONLY** when the chair is being relocated; and reset the caster brakes upon arriving at your destination. **NEVER** assume that the caster brakes have been set; check to ensure that the caster brakes are engaged before helping anyone in or out of the recliner.

Note: Always rotate casters to the front of the chair for ease of locking and monitoring status, do this on arrival at your destination by pushing (or pulling) the chair to the front and then pulling (or pushing) the chair to the back to rotate the casters to the front.



WARNING: DO NOT enter or exit the chair with the leg rest extended.

2. Place the chair in the upright position before allowing the patient in or out of the chair. **DO NOT** enter or exit the chair with the leg rest extended. For shorter patients the foot tray may be used as an assist to allow easier entry to the chair. Patients over 225 pounds should not use the foot tray as a step. Please note and follow the capacity limits of the recliner being used.
3. Caster brakes should be locked before using the removable arm top or swing-away arm option.
4. If applicable, the removable arm top should be replaced and securely latched as soon as a patient transfer has been made.
5. Swing-away arm should be closed and the arm securely latched as soon as the transfer or maintenance operation is complete. An occupant should **NEVER** be transported with the arm top removed or the swing-away arm opened. Chairs with removable or swing away arms should **NEVER** be left unattended when an arm is not secured. Check that the arm is latched by pulling outward on the arm.



CAUTION: Caregiver should NEVER attempt to raise the front wheels off the floor by pushing on the rear handle with a patient in the chair. This could damage the chair mechanism.

6. When transporting a patient, pull the foot tray out to the extended position, and be sure that the chair is in the upright position. **Any recliner not equipped with a foot tray is not considered an appropriate transport chair. NEVER** move recliner while patients are in the seat with their feet dangling.

This recliner is designed with a “**zero-wall**” type mechanism. (All mechanisms require some space between the chair back and the wall for proper operation). The chair seat and back move forward with you when you recline. Remember that the chair occupant will move in the same manner as they recline in the chair. The mechanism maintains the patient’s weight over the center of the chair and **operates best with the patient seated all the way to the back of the chair.**

MANUAL RECLINER OPERATING INSTRUCTIONS

Champion Recliner Operation One-Pager



1
LOCK CASTERS



2
EXTEND PULL-OUT STEP



3
ENTER AND SIT BACK



4
UPRIGHT POSITION



5
RELEASE HAND LEVER FOR "TV" POSITION. Foot rest will rise.



6
"TV" POSITION



7
PUSH BACK WITH HEAD AND SHOULDERS. To assist, grasp recliner arms and pull hips forward.



8
FULL RECLINE



9
SIT UP TO RETURN TO "TV" POSITION. To assist, grasp recliner arms and push hips back.



10
RETURN TO UPRIGHT POSITION. Foot rest will "click" when latched.



11
UPRIGHT POSITION FOR EXITING CHAIR



12
EXITING THE CHAIR

Exiting with Attendant Assistance



1
Locate and move hands and feet to safe location.



2
Move to the rear of the chair and use push handle to lift back to "TV" position.



3
Move to front of the chair and push the foot rest closed.



4
Allow exit once foot rest is latched.



NEVER exit without closing foot rest.



NEVER exit while reclined or if foot rest is extended.



NEVER exit from the side of the chair.



NEVER put your hands into the mechanism area.



NEVER put your hands into the mechanism area.

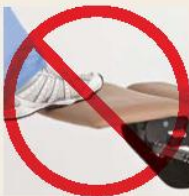

NEVER force the foot rest closed.

MANUAL RECLINER OPERATING INSTRUCTIONS

Chair Positions (Upright, TV, and Full Recline)

 **WARNING: NEVER place your hands near or on a recliner mechanism when it is in motion. DO NOT put your hands where you cannot see.**

 **WARNING: A caregiver can control the motion of a leg rest as the chair moves from upright to “TV”. To do so, place your palm against the upholstered top of the leg rest, well away from scissors of the mechanism below the short sides of the footrest. Release the leg rest with your opposite hand and use your palm to control the motion.**

To Move From Upright to the “TV” Position

1. With the chair in the upright position, set or confirm that the caster brakes are set.
2. Occupant should sit down and fully back in the chair with calves touching the leg rest.
3. Pull the mechanism release lever located on the lower arm panel.
4. Raise your feet and legs to recline to the “TV” position.

Note: To assist an occupant in raising their leg rest, grasp the leg rest near the center on a “long” side, well away from the recliner mechanism.

Note: It is not possible to recline the chair unless the recline release lever has been activated. It is not necessary to operate the recline release to close the leg rest.

To Move From “TV” Position to Full Recline Position

1. From “TV” position, push back with your head and shoulders to move your body forward, moving easily to a full recline position.
2. Should the occupant be in a weakened condition and need help to recline, downward pressure may be applied to the push handle, located at the back of the chair; or directly to the back itself.

Note: DO NOT push on the chair arms to assist chair operation; if necessary, grasp the chair arms and pull to help move your body forward into the full recline position.

 **CAUTION: DO NOT attempt to close the chair’s leg rest while in the full recline position. Doing so may damage the mechanism and void your warranty. Return the chair to the “TV” position before closing the leg rest.**

To Return to the “TV” Position

1. Simply lean forward; raising head and shoulders up should return the chair to “TV” position.
2. If this does not return the chair to “TV” position, you may push on the chair arms to help move your body backwards into the “TV” position.

Note: DO NOT pull on the arms; this will move your body the wrong way.

MANUAL RECLINER OPERATING INSTRUCTIONS (continued)



WARNING: DO NOT put your hands where you cannot see. To assist a patient in closing the leg rest; place your palm against the upholstered top surface and press downward in the center well away from the recline mechanism at the sides.

To Return to a Full Upright Position From “TV” Position

1. Apply pressure to the leg rest until the leg rest returns to the locked position and the back is in the upright position.

Trendelenburg Option

It is recommended that health care professionals who will be using this chair become thoroughly acquainted with the recliner and the Trendelenburg option prior to its use with a patient.



CAUTION: Operation of the Trendelenburg option must be in the proper sequence to be effective. First move through the recline functions, then actuate the trend option.



CAUTION: The Trendelenburg release must be fully actuated and held for the chair to operate properly.



CAUTION: Once the chair has been placed in full Trendelenburg position, it is possible to adjust the Trendelenburg position upward ONLY after returning the chair from Trendelenburg to “TV” position, and back through full recline; STOPPING THE CHAIR AT THE DESIRED POSITION WHILE ON THE WAY DOWN.

To Actuate the Trendelenburg Option

1. Follow the operating instructions to place the chair in a full recline position.
2. Locate the Trendelenburg actuator release lever on the chair back.
3. Grasp the push handle, “**pull and hold**” the Trendelenburg release lever. Lower the chair and occupant to the Trendelenburg position. Release the actuator to lock the chair back in position. Should you choose to place the chair in a position short of full Trendelenburg, stop the chair back at the desired position and release the actuator while in motion.

To Return from Trendelenburg Position

1. “**Pull and hold**” the Trendelenburg actuator release lever as you lift the chair back to the “TV position”. Release the actuator to lock the back in position.
2. The chair may now be actuated into any of the standard chair positions according to the operating instructions.

MANUAL RECLINER OPERATING INSTRUCTIONS (continued)



CAUTION: DO NOT overload chair. Observe the specified maximum weight limit for the recliner model that you have selected.



CAUTION: DO NOT attempt to force the chair into position; permanent damage may result. The chair works with normal effort when operated properly.



CAUTION: DO NOT attempt to close leg rest unless the chair is in “TV” position. (seat all the way in and back upright)



CAUTION: DO NOT use Trendelenburg lever to recline the chair. ALWAYS return chair to “TV position” after using Trendelenburg. Failure to do so may not allow back to be put into the Trendelenburg position when needed.



WARNING: Keep hands, feet and legs clear of the recline mechanism.

Actuation of the recline and Trendelenburg device by staff

In the event that a chair is not in full recline, and the chair occupant’s condition makes them unable to assist the staff in movement of the chair from one position to another; the following is recommended:

1. To move the chair from full upright position to TV position, stand facing the side of the chair with the mechanism actuator, pull and hold the actuator while raising the footrest to reach the “TV” position. To raise the footrest grasp in the center on a long side well away from the recliner’s scissor mechanism.
2. Turn and face the chair occupant, grasp the leg rest on the long side, at the edge toward the patient, near the middle well away from the recliner’s scissor mechanism. Pull up and back to move the chair to full recline position **or simply place your hand on the back pillow and push downward to move to full recline position.**
3. Move to the back or turn to the side of the chair and actuate the Trendelenburg option according to the aforementioned directions. You may push on the back as you pull and hold the Trendelenburg actuator to move the chair rapidly to full Trendelenburg.

MANUAL RECLINER OPERATING INSTRUCTIONS (continued)

Setting the Trendelenburg Feature One-Pager

The Trendelenburg function should be operated by the caregiver. Your chair must be purchased with the Trendelenburg option when it was ordered. If your chair has this option, follow these directions for operation.

1 ADJUST TO FULL RECLINE POSITION

Before operating the Trendelenburg function, you must move the chair to the full-recline position. Pull the side lever to release the foot rest. Then push the chair backrest as far as it will go into the full-recline position.



RELEASE FOOT REST WITH SIDE LEVER



TV POSITION



FULL RECLINE POSITION

2 PLACE THE RECLINER IN THE TRENDELENBURG POSITION

Locate the Trendelenburg lever on the chair back (shown to the right). Pull the lever all the way up and hold as you push the backrest down as far as it will go to the Trendelenburg position (shown to the right bottom). You may stop at any position going downward by releasing the lever.

Please note: The caregiver is shown at the back of the chair in these instructions for clarity. You may also perform this function from the side of the chair.



LOCATE BACK LEVER



RAISE AND HOLD LEVER



PUSH RECLINER BACK DOWN



FULL TRENDELENBURG POSITION

3 RETURN TO UPRIGHT POSITION

To return the chair to upright position, locate the Trendelenburg lever on the chair back. Pull the lever all the way up and hold as you lift the backrest and return it to the fully-upright/TV position (shown at bottom right). It is recommended that this step be done from the back of the chair.



LOCATE BACK LEVER



RAISE AND HOLD LEVER



LIFT RECLINER BACK UP

4 RAISE TO FULL UPRIGHT POSITION

Once the backrest is returned to the fully-upright/TV position, push the foot rest down until you hear it click and lock in place. To avoid damage to the mechanism, the foot rest should never be pushed down until the backrest is returned to the fully-upright/TV position.



RAISE BACK OF RECLINER





PRESS FOOT REST DOWN



FINAL UPRIGHT POSITION

POWER RECLINER OPERATING INSTRUCTIONS

SPECIAL NOTES

 **WARNING/**  **CAUTION** These terms refer to actions that may result in injury to your patient or staff member and/or damage to your product. Damage caused by improper operation of your chair is not covered by your warranty.

 **WARNING: DO NOT** operate this product without reviewing the in-service manual that demonstrates proper operation. This information accompanied your shipment.

 **WARNING:** The power cord must be plugged into a properly grounded outlet and must not be modified in any way. If the 3-blade plug does not fit your outlet, have a new outlet installed that meets your local codes by an electrician. **DO NOT** use a 3-prong to 2-prong plug adapter. Consult an electrician if you are unsure that the outlets are properly grounded.

 **WARNING:** Keep hands, all other body parts and equipment away from moving parts that can cause pinch points. **DO NOT** reach to the inside of the chair unless the chair is unplugged from the outlet and the optional battery is disconnected to avoid injury if the chair position is changed. Caregiver assisting an occupant should always locate and safely place the occupant's extremities away from possible pinch points.

 **CAUTION:** Operating the recliner mechanism when the chair back is restricted and cannot move up and down freely may damage your mechanism. Be certain that the chair back as well as the push handle **DO NOT** make contact with the walls, counters or other furniture or equipment.

Note: The information contained in this document is subject to change without notice.

POWER RECLINER OPERATING INSTRUCTIONS (continued)

General Set Up

1. Uncoil the power cable from the back side of the power recliner and plug it into a properly grounded outlet. Please see the power requirements in the chair specifications section of this manual.
2. To fully charge the battery for the first time, the chair must be plugged in for 10 hours. The battery is charging whenever the chair is plugged in.
3. **ALWAYS** set the caster brakes before allowing your occupant to get in or out of the chair. Release the caster brakes **ONLY** when the chair is being relocated and reset the caster brakes upon arriving at your destination. **NEVER** assume that the caster brakes have been set. Check to ensure that the caster brakes are engaged before helping anyone in or out of the recliner.
4. Place the chair in the upright position before allowing the occupant in or out of the chair. **DO NOT** enter or exit the chair with the leg rest extended. For shorter occupants the foot tray may be used as an assist to allow easier entry to the chair. **Occupants over 225 pounds SHOULD NOT use the foot tray as a step.** Please note and follow the capacity limits of the recliner being used.
5. Caster brakes should be locked before using the removable arm top or swing-away arm option.
6. A swing-away arm should be closed and the arm securely latched as soon as the transfer or maintenance operation is complete. An occupant should **NEVER** be transported with the swing-away arm open. Chairs with swing away arms should **NEVER** be left unattended when an arm is not secured. Check that the arm is latched by pulling outward on the arm.
7. When transporting an occupant, pull the foot tray out to the extended position, and be sure that the chair is locked in the upright position. **Any recliner not equipped with a foot tray is not considered an appropriate transport chair. NEVER** move recliner while occupant is in seat with their feet dangling.

 **WARNING: Please keep hands, all other body parts, and equipment away from moving parts that can cause pinch points. DO NOT reach to the inside of the chair unless the chair is unplugged from the outlet and the battery, if present, is disconnected to avoid injury if the chair position is changed.**

 **WARNING: DO NOT enter or exit the chair with the leg rest extended.**

 **WARNING: To reduce the risk of electric shock, always unplug this product from the wall outlet before cleaning, disinfecting, or replacing any parts.**

 **WARNING: NEVER operate the chair if it has a damaged cord or plug, if it is not working properly, if it has been damaged, or is not dry. DO NOT use outdoors.**

POWER RECLINER OPERATING INSTRUCTIONS (continued)

 **WARNING:** Please keep hands and equipment away from moving parts that can cause pinch points.

 **WARNING:** NEVER operate this product if it has a damaged cord or plug, if it is not working properly, if it has been dropped or damaged, or dropped into water.

 **WARNING:** Always check the power and handset cords are intact prior to switching the unit on.

 **WARNING:** NEVER service this chair without unplugging the cord from the wall. DO NOT put your hands where you cannot see.

 **WARNING:** Keep chair and electronics dry – DO NOT operate in a wet or moist condition or environment. DO NOT power wash chair or electronics or swab down electronics with a wet mop.

 **CAUTION:** The battery is a backup system to be used for power outages and occupant transport.

 **CAUTION:** It is not recommended to let the battery drop below 30% charge. This will permanently damage the battery causing it to no longer hold a full charge. This will void your warranty on the battery.

 **CAUTION:** Caregiver should NEVER attempt to raise the front wheels off the floor by pushing on the handle with an occupant in the chair. This could damage the chair mechanism.

 **CAUTION:** As you Unplug chair from the wall outlet examine your cord and plug for wear or damage including, but not limited to wear, cuts, breaks, or bent prongs.

 **CAUTION:** DO NOT pull the chair with the power cord.

 **CAUTION:** DO NOT roll chair or other equipment over the power cord or the cord to the handset.

 **CAUTION:** DO NOT modify the plug or use an extension cord or adapter to plug into the wall outlet.

POWER RECLINER OPERATING INSTRUCTIONS (continued)

Handset Operation

The positioning of the Champion power recliner is controlled by the handset shown below. The handset allows total occupant control of the chair reclining function with the touch of a button. The power recliner can be positioned from full upright to full recline and any position in between to maximize comfort.

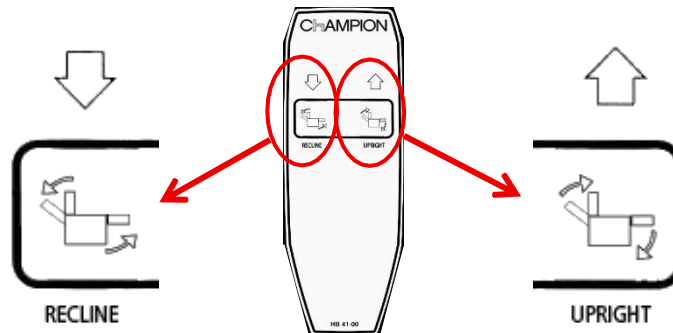

WARNING: NEVER place your hands near or on a recliner mechanism when it is in motion. DO NOT put your hands where you cannot see.

Reclining the Chair

Pressing and holding the left “recline” button will take the chair from upright to full recline. The down arrow above the button shows the action of the back of the chair as it goes down into the recline position. The chair can be stopped in any position along its motion. Occupant’s movement will not cause the chair to move as with the standard recliners. Once the chair reaches full recline the movement will stop. Use the “upright” button to return to the full upright position.

Recline to Upright

Pressing and holding the right “upright” button will take the chair from full recline to upright. The up arrow above the button is showing the action of the back of the chair as it rises back into the upright position. The chair can be stopped in any position along its motion. Occupant’s movement will not cause the chair to move as with the standard recliners. Once the chair reaches full upright the movement will stop. Use the “recline” button if you wish to recline again.

POWER RECLINER OPERATING INSTRUCTIONS (continued)

Trendelenburg Operation

We recommend that health care professionals who will be using this chair become thoroughly acquainted with the recliner and the Trendelenburg option prior to its use with an occupant.



CAUTION: The Trendelenburg release must be fully actuated and held for the chair to operate properly.

To Actuate the Trendelenburg Option

1. Follow the operating instructions to place the chair in a full recline position.
2. Locate the Trendelenburg actuator release lever on the chair back.
3. Grasp the push handle, “**pull and hold**” the Trendelenburg release lever. Lower the chair and occupant to the Trendelenburg position. Release the actuator to lock the chair back in position. Should you choose to place the chair in a position short of full Trendelenburg, stop the chair back at the desired position and release the actuator while in motion.

To Return from Trendelenburg Position

1. “**Pull and hold**” the Trendelenburg actuator release lever as you lift the chair back to the “TV position”. Release the actuator to lock the back in position.
2. With the back all the way out of Trendelenburg the safety limit switch will be released, and motor function will resume as described above.
3. The chair may now be moved into any of the standard chair positions according to the operating instructions.

POWER RECLINER CONNECTIONS

Power Connections

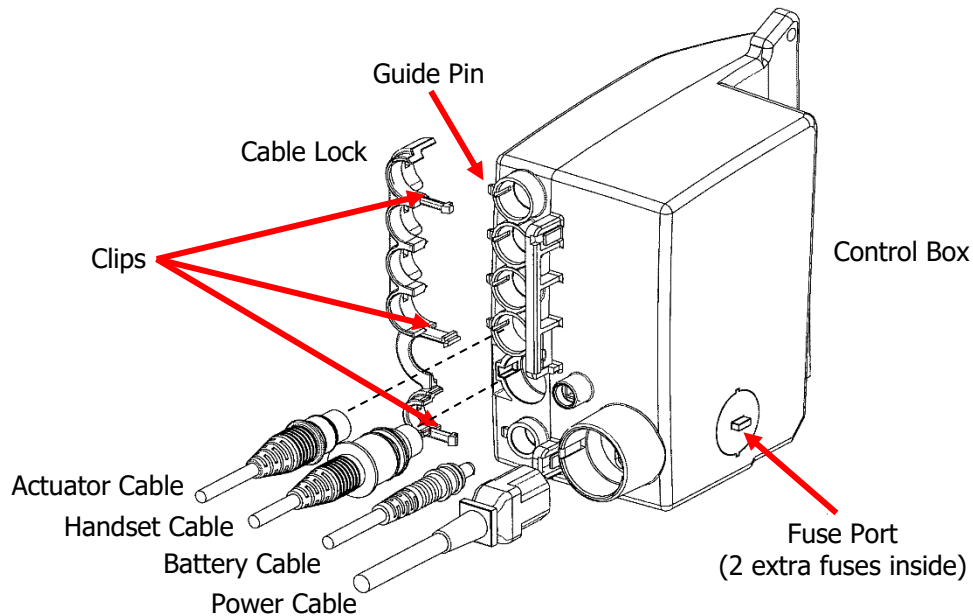

Remove Cables

1. Remove the cable lock. This may require a small screwdriver to undo the clips on the control box.
2. Pull the desired cable out of the control box. The power cable has a clip that may require a screwdriver to release.

Install Cables

1. Insert each cable into the port shown above. Some of the connectors have a guide pin for alignment.
2. Install the cable lock over the cables and make sure all three clips have locked in place. This prevents the cables from being pulled out accidentally.

HEAT & HEAT/MASSAGE OPERATION

General Information

The Champion heated recliner continues to have the same occupant-controlled positioning with the added benefit of heated pads in the seat and back. The heat/massage recliner has massage motors built into the back cushion along with the heat system. This allows for additional occupant comfort at the push of a button.

 **WARNING: DO NOT operate this product without reviewing the operating instructions along with any attachments that demonstrate proper operation of the basic functions of your chair.**

 **WARNING: No items should be placed behind the occupant's back or beneath them. Placing items (pillow, blanket, etc.) in the chair will expose the item to the heat generated by the system. Unlike the occupant's body, certain items may not absorb and dissipate the generated heat; this may expose the item to temperatures that are higher than noted here through trapped heat. This may cause damage to the chair, the item, and risk of contact with higher temperatures. Damage to the item or your chair is not covered by your warranty.**

 **WARNING: Please keep hands and equipment away from moving parts that can cause pinch points.**

 **WARNING: NEVER operate this product if it has a damaged cord or plug, if it is not working properly, if it has been dropped or damaged, or dropped into water.**

 **WARNING: NEVER insert pins or other metallic fasteners into the upholstery of this chair.**

 **WARNING: Always check the power and handset cords are intact prior to switching the unit on.**

 **WARNING: NEVER service this chair without unplugging the cord from the wall. DO NOT put your hands where you cannot see.**

 **WARNING: DO NOT crush or pinch heating elements or wiring.**

 **WARNING: The heat or heat/massage chair must be plugged into a properly grounded outlet and must not be modified in any way. If the three (3) blade plug does not fit your outlet, have one installed that meets your local codes by an electrician. Consult an electrician if you are unsure that the outlets are properly grounded. DO NOT use a three (3) blade plug to a two (2) blade adapter.**

HEAT & HEAT/MASSAGE OPERATION (continued)

 **CAUTION:** Make sure all staff involved in the use of the chair has viewed the in-service instruction pages prior to operating the chair. Incorrect use can damage the chair and void your warranty.

 **CAUTION:** To prevent damage to the power cord, **DO NOT** allow power cord or handset cord to end up under the wheels or other heavy objects. **DO NOT** leave power cord close to a source of heat. When removing the power cord from the wall outlet, grasp the plug and **NOT** the cord.

 **CAUTION:** **DO NOT** pull this product by the power cord or the handset.

 **CAUTION:** Use this product only for the intended use as described in this manual. **DO NOT** use attachments not recommended by the manufacturer.

 **CAUTION:** Clean switch with a moist cloth only, **DO NOT** allow liquids to pool around the switch.

 **CAUTION:** **DO NOT** use with an extension cord.

 **CAUTION:** Take care so cord cannot be pulled or tripped over.

 **CAUTION:** **KEEP DRY - DO NOT** operate in wet conditions or environments.

 **CAUTION:** **DO NOT** use heat with invalid or unconscious person or occupants who cannot feel if the seat is being too warm.

 **CAUTION:** Keep cord away from heated surfaces.

 **CAUTION:** **DO NOT** use outdoors.

 **CAUTION:** Supervision should be provided when this product is used by children, invalids, or disabled persons.

 **CAUTION:** **DO NOT** place cord under carpet or in a location where it could become worn.

HEAT & HEAT/MASSAGE OPERATION (continued)

Heat & Heat/Massage Operation

Uncoil the power cord on the back of the chair and plug it into any properly grounded standard wall outlet. You will find the heat and massage buttons on the table of the chair. This will typically be the right table (while seated in the chair) unless other options require it to be on the left side.

The heating elements are located in the seat & the seat-back of chair.

The massage option uses four (4) separate motors located in the backrest of the chair. Two in the lower backrest, and two in the middle (upper) backrest.



HEAT/MASSAGE



HEAT ONLY

To operate, push HEAT or MASSAGE button - See indicator light on switch.

Heat

- 3 Lights** = High Heat/Bright Light
- 2 Lights** = Medium Heat/Medium Light
- 1 Light** = Low Heat/Dim Light
- No Light** = HEAT OFF

Massage

- 1X** = Lower Back/Low Intensity
- 2X** = Lower Back/High Intensity
- 3X** = Upper & Lower Back/Low Intensity
- 4X** = Upper & Lower Back/High Intensity
- 5X** = Alternating Upper & Lower Back
- 6X** = MASSAGE OFF

Note: Allow 5 to 8 minutes for seat-back and seat to warm to desired setting.

Note: Heat will automatically shut off after approximately 60 minutes. (Timer resets each time switch is pressed).

Note: Massage will automatically shut off after approximately 15 minutes. (Timer resets each time switch is pressed).

Troubleshooting

If the lights on the switch are flashing, **FIRST unplug the chair from the outlet and check all of the connectors of the heat system.** If a connector is unhooked reconnect it, plug in the power cord, and check the switch again. If all connections appear ok and the lights still flash, unplug your chair and contact Champion's Customer Experience. This does not affect the basic functions of the chair.

OPERATING OF SWING-AWAY ARMS



WARNING: The recliner has moving parts that create pinch points. When the swing-away arms are open, those points are fully exposed. Patients should NEVER be left in a chair with the arms in the open position. THE CHAIR SHOULD NOT BE LEFT UNATTENDED, WITH THE ARMS UNLATCHED.



CAUTION: Be aware of the path the arm is taking. Swinging the arm into objects may result in vinyl damage. It is recommended that opening the arm be done with the chair in the fully upright position or the fully reclined position. If the arm on the chair is equipped with a fold-down table, relocate the items on the table top and fold the table top down.

Swing-away arms hinge at the back and may be opened a full 180 degrees. To do this, stand at the side of the chair, grasp the release handle and lift to release, and swing the arm open.

Once a patient transfer or maintenance is complete, the arm should be returned to the locked position. To do this, swing the arm back toward the front of the chair until you hear the “click” of the release handle being secured by the latch; **pull outward on the arm to ensure the arm is securely latched.** It may be necessary to lift slightly to move the arm into position for the handle to latch.

Note: The swing-away arms may be opened in the **upright position** to allow access to the thumb-knobs that secure the quick release seat to the mechanism. The balance of the operation of removing the quick release seat is as noted in this manual.

OPERATION OF FOOT TRAY

The foot tray is a feature available on many Champion recliner models. The foot tray is useful as an assist for patients getting into or out of the recliner, re-positioning in the recliner, and as a foot support while sitting fully upright or being transported in the recliner.



WARNING: NEVER move chair while patient is in the seat in the upright position with their feet dangling.



WARNING: The foot tray can support up to 225 lbs. Patients over 225 lbs. should NOT use the foot tray as a step.

The foot tray pulls out from under the recliner footrest. Before use, make sure chair casters are locked and ensure that the foot tray is in the fully-extended position. To fully extend the foot tray, pull it out from the front of the recliner until you feel the front edge of the foot tray drop slightly. In this position, the foot tray cannot be pushed back under the chair to the “stowed” position unless you first lift on the front edge of the tray.

To stow the foot tray, lift up on the front edge of the tray and slide it back under the recliner as far as it will go.

Staff should always advise patients that the foot tray has been extended. Staff should **NEVER** allow a patient to stand on the foot tray unattended.



WARNING: Any recliner NOT equipped with a foot tray is NOT considered an appropriate transport chair.

OPTIONS & ACCESSORIES

Options

Chair features that must be installed at the factory when the chairs are produced.

Central Locking Caster Option

The central locking caster feature is available only on swing-away arm chairs, enables the staff to lock all four casters with pressure from their foot. The red side locks the casters, and the green side of the pedal unlocks them.



Trendelenburg Option

The Trendelenburg feature creates multiple positions from full recline through flat to full Trendelenburg. Use this feature only when the chair is in full recline position.

TV Bracket

Right-hand mounting bracket for use with your selected monitor/television system.

Accessories

Features that may be ordered for your Champion chairs at any time. Some installation may be required. Accessories can be installed in the factory or in the field by the facility.

Fold-Away Side Tables

The fold-away side tables are mounted on the arms of the chair and can be ordered with cup holders.

Operate by:

1. Raising table and securing both support brackets.
2. Release brackets to return to stored position.



WARNING: DO NOT use table as a seat.



CAUTION: Remove items and fold tables down prior to moving the chair or the swing-away arm.

Cushion Wedge

This removable support provides additional surface for arm support as well as closing the gap between inside of chair arms for smaller patients.

OPTIONS & ACCESSORIES (continued)



CAUTION: DO NOT place comfort items between patient and heat source in chair if chair is equipped with heat. The comfort item may trap heat and when the item is removed the patient may experience elevated temperatures.

Head Pillow/Lumbar Support

This removable cushion can be used for head or lumbar support. The pillow attaches around back of chair with hook and loop fastener strap to allow placement of pillow at various positions to best suit the patient.

IV Pole

Stainless construction, 1" diameter IV pole features two or four rams horn hooks, adjustable with infinite positions; extended effective length 64".

IV Pole Bracket

This bracket is used to mount IV pole on backside of either or both arms and accommodates a 1" diameter pole.

IV Pole Base

The IV pole base accepts transfer of IV pole from chair bracket to IV pole base allowing patient to be mobile and free of the chair.

Dual Remote Controls

Caregivers will have added control with the addition of a 2nd remote. In the event that a caregiver would have to reposition an occupant without being able to utilize the occupant control they would have the 2nd remote to place them in the full recline position to use Trendelenburg or sit them up to the full upright position.

NOTE: Not all chair functions, options and/or accessories are covered in this manual.

OPTIONS & ACCESSORIES (continued)

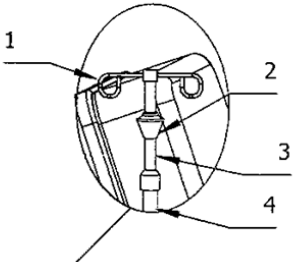
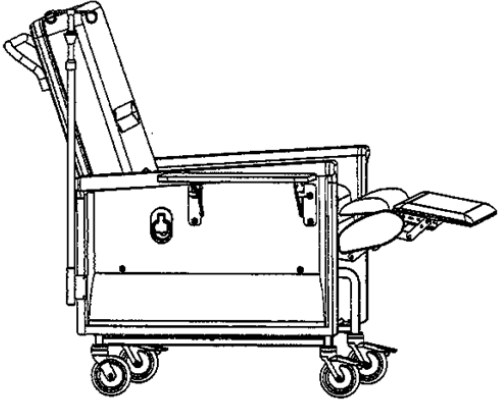
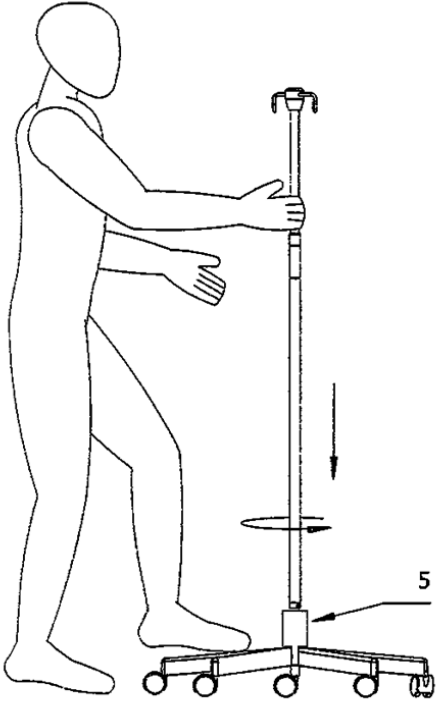
<p>USE OF IV POLE</p> <p>THIS INSTRUCTION SHOWS HOW TO USE THE IV POLE INFINITE POSITION FEATURE. HOW TO USE WITH BASE UNIT.</p>	<table border="1" style="width: 100%; border-collapse: collapse;"> <tr><td style="width: 20px; text-align: center;">1</td><td>HOOK</td></tr> <tr><td style="text-align: center;">2</td><td>RELEASE BUTTON</td></tr> <tr><td style="text-align: center;">3</td><td>TOP SECTION OF TUBE</td></tr> <tr><td style="text-align: center;">4</td><td>BOTTOM SECTION OF TUBE</td></tr> <tr><td style="text-align: center;">5</td><td>IV POLE BASE UNIT</td></tr> </table>	1	HOOK	2	RELEASE BUTTON	3	TOP SECTION OF TUBE	4	BOTTOM SECTION OF TUBE	5	IV POLE BASE UNIT
1	HOOK										
2	RELEASE BUTTON										
3	TOP SECTION OF TUBE										
4	BOTTOM SECTION OF TUBE										
5	IV POLE BASE UNIT										
 	<div style="border: 1px solid black; padding: 5px; margin-bottom: 10px;"> <p>TO INSERT: PLACE IV POLE OVER CENTER, PUSH INTO POSITION IN OPENING. AND TURN TO LOCK.</p> </div> <div style="border: 1px solid black; padding: 5px; margin-bottom: 10px;"> <p>TO REMOVE: HOLD BASE IN POSITION WITH FOOT. TURN TO UNLOCK LIFT IV POLE TO REMOVE.</p> </div>										
<p>TO RAISE: LIFT TOP SECTION TO DESIRED HEIGHT</p> <p>TO LOWER: GRASP TOP SECTION OF TUBE AS YOU PUSH UP SLIGHTLY ON RELEASE. LOWER TOP SECTION OF TUBE. LOWER TO DESIRED HEIGHT.</p>											

Note: Some components may have a different appearance than shown in the picture due to multiple models of chairs. The serial number of the chair informs Customer Experience of the proper components for that chair.

OPTIONS & ACCESSORIES (continued)

Stand-Alone and Integrated USB

The USB Charging Port is strictly a charging port and does not transfer data. This is applicable to both the integrated and stand-alone USB options. Charging time of device will vary depending on charging cord and device type.

USB Operation

Open the rubber dust cover and insert USB charging cord. The blue light on the port glows when the charging port is in operation. Remove the charging cord and replace dust cover when port is not in use.

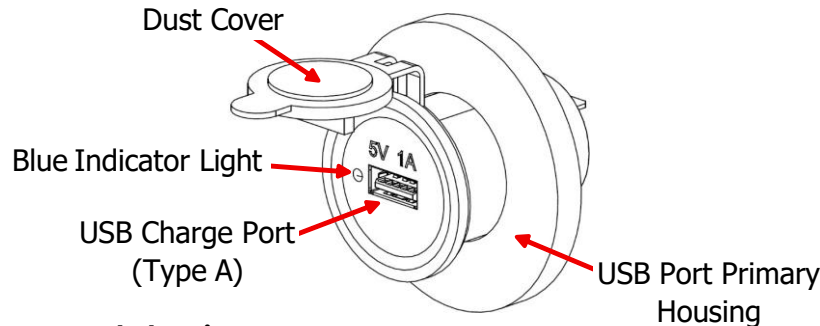

USB Charger Port General Cleaning

The rubber dust cover does not provide a seal. Care should be taken while cleaning around the port as not to let moisture enter the electrical components.

 **CAUTION: DO NOT allow moisture to pool in or around the USB Charging Port.**

If dust or debris is noticed the USB port may be cleaned using compressed air to blow the particles out.

USB Power Connections

Stand-Alone USB

The stand-alone USB port is to be plugged into a properly grounded standard wall outlet. (Stand-alone USB outlet plug is not shown)

Integrated USB (into a power only chair)

The integrated USB port is to be plugged into a properly grounded standard wall outlet. (Integrated USB outlet plug is not shown)

Integrated USB (into a power, heat, and/or massage chair)

The integrated USB port to a powered heat and/or massage chair is plugged into the Control box - Accessory Connector Plug. The Control box is then plugged into a properly grounded standard wall outlet by utilizing the AC Connector. (AC connector cord with plug is not shown)

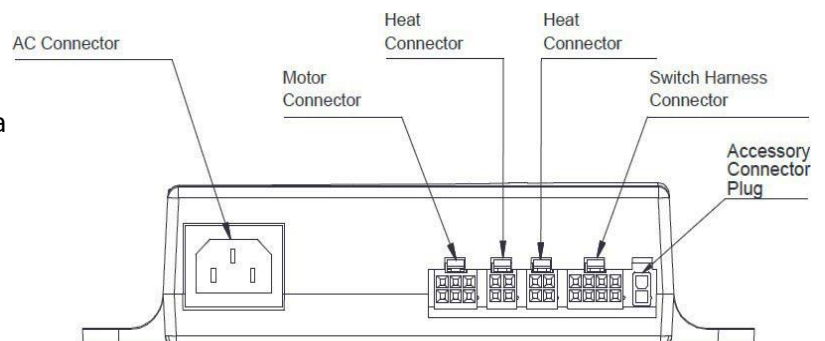

GENERAL MAINTENANCE AND CARE

General Information

Regular and careful cleaning of the upholstery with water and a mild soap can prevent hardening and embrittlement of the upholstered parts from such problems as body perspiration, skin oils, hair spray, hand creams and similar things that may affect the upholstery.

It is not necessary or recommended that moving parts of the chairs be lubricated. Keeping the chair clean is the main maintenance requirement. Each facility should check their chairs and set their own maintenance schedule.

It is recommended that the underside of the chairs be checked periodically for waste materials that have fallen under the chair. For this purpose, use the quick-release seat feature to help gain access for removal of the waste. It is also recommended that the thumb screws on the quick-release seat be periodically checked to make sure they are tight.

Check that the hinge fasteners, latch mount and release mount fasteners are secure on the swing-away arm chairs. The top of each latch mount has plastic buttons that are designed wear points. Check the buttons and replace when worn to prevent damage to vinyl covers. These checks should be done monthly and then tailored to your findings.

If a part becomes worn or broken, see the sections regarding service and warranty for information, please reference service and warranty section of this manual.

Please advise your cleaning staff to keep in mind these safety instructions.



WARNING: Place chair in a fully upright and securely latched position or a fully reclined position when cleaning or maintaining your chair. The recliner has moving parts that create pinch points.



WARNING: NEVER clean or maintain your chair with an occupant in the chair.



WARNING: To reduce the risk of electric shock, always unplug this product from the wall outlet before cleaning, disinfecting, or replacing any parts.



WARNING: NEVER operate the chair if it has a damaged cord or plug, if it is not working properly, if it has been damaged, or is not dry.



WARNING: Keep chair and electronics dry - DO NOT operate in a wet or moist condition or environment.



WARNING: NEVER clean the chair in a wash tunnel, with a high-pressure cleaner, hose, or spray liquids, including electronics. DO NOT swab down electronics with a wet mop.

GENERAL MAINTENANCE AND CARE (continued)



CAUTION: NEVER lubricate the Trendelenburg mechanism; doing so may cause the Trendelenburg mechanism to fail. Note: this mechanism is particularly prone to damage due to power washing.



CAUTION: Avoid liquid ingress into all electronic components.



CAUTION: As you unplug chair from the wall outlet examine your cord and plug for wear or damage including, but not limited to wear, cuts, breaks, or bent prongs.



CAUTION: DO NOT pull the chair by the power cord.



CAUTION: DO NOT roll chair or other equipment over the power cord or the cord to the handset.



CAUTION: DO NOT modify the plug or use an extension cord or adapter to plug into the wall outlet.



CAUTION: DO NOT use outdoors.



CAUTION: DO NOT allow moisture to pool on top of any switches.

GENERAL MAINTENANCE AND CARE (continued)

USE OF QUICK RELEASE SEAT FEATURE

WARNING: THIS CHAIR HAS MOVING PARTS THAT MAY CREATE PINCH POINTS. WORK OR CLEANING SHOULD BE PERFORMED ONLY IN THE UPRIGHT POSITION WITH THE CHAIR LATCHED OR IN THE FULL RECLINE POSITION. KEEP YOUR HANDS CLEAR OF THE MECHANISM WHEN MOVING THE CHAIR FROM ONE POSITION TO ANOTHER.

A	BACK PILLOW
B	SEAT
C	CENTER BOARD
D	FOOT REST
E	LEG REST MECHANISM SIDE COVER
F	FOOT TRAY
G	UPHOLSTERED ARM
H	RECLINE MECHANISM ACTUATOR
I	THUMB KNOB

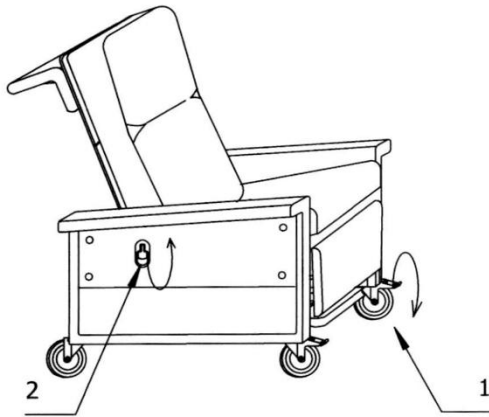

1. LOCK FRONT CASTERS
2. OPERATE RECLINE MECHANISM ACTUATOR

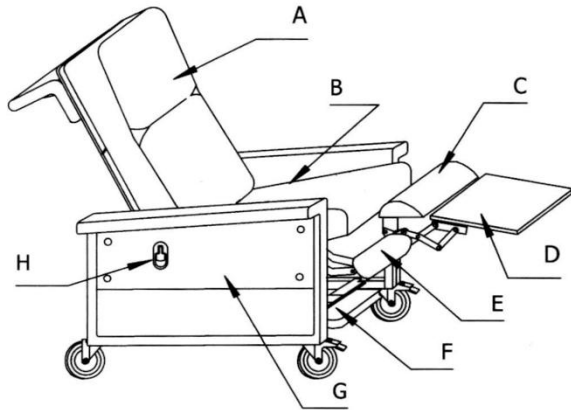

3. CHAIR SHOWN IN "TV" POSITION, CASTERS LOCKED.

THIS ILLUSTRATION SHOWS HOW TO PLACE A RECLINER-TRANSPORTER IN "TV" POSITION.
ALSO USE THE ILLUSTRATION TO IDENTIFY BASIC CHAIR PARTS

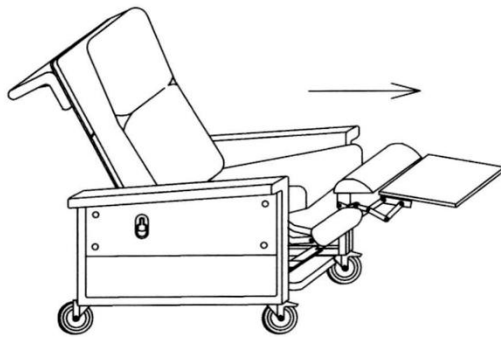

4. WITH CHAIR IN "TV" POSITION, PULL LEG REST FORWARD TO GO TO THE FULL RECLINE POSITION TO EXPOSE THE THUMB KNOBS THAT SECURE THE SEAT.

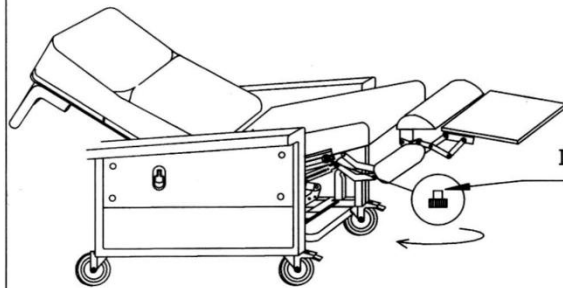

5. LOCATE AND REMOVE THE THUMB KNOBS THAT SECURE THE SEAT. DO NOT REMOVE THE SEAT.

THIS ILLUSTRATION SHOWS THE LOCATION AND HOW TO REMOVE THE SEAT FASTENERS.

Note: Some components may have a different appearance than shown in the picture due to multiple models of chairs. The serial number of the chair informs Customer Experience of the proper components for that chair.

GENERAL MAINTENANCE AND CARE (continued)

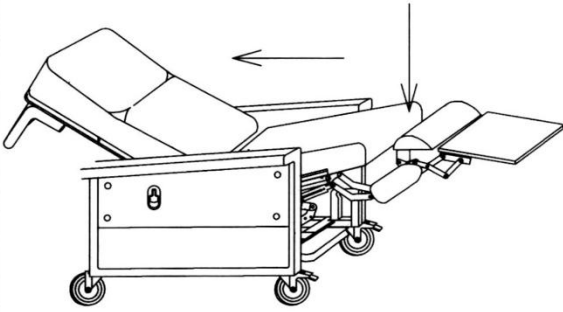
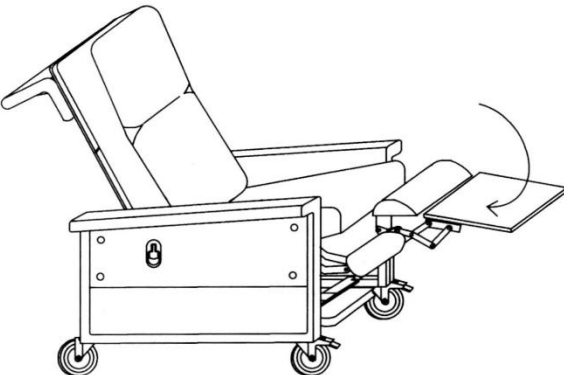
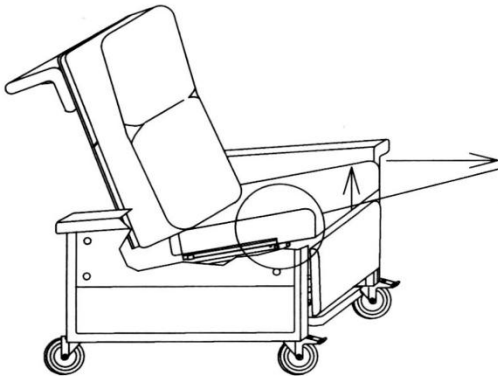
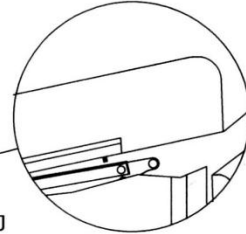
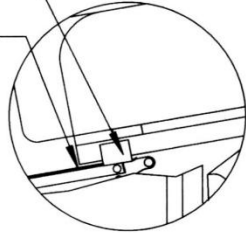
<p>USE OF QUICK RELEASE SEAT FEATURE</p> <p>WARNING: THIS CHAIR HAS MOVING PARTS THAT MAY CREATE PINCH POINTS. WORK OR CLEANING SHOULD BE PERFORMED ONLY IN THE UPRIGHT POSITION WITH THE CHAIR LATCHED OR IN THE FULL RECLINE POSITION. KEEP YOUR HANDS CLEAR OF THE MECHANISM WHEN MOVING THE CHAIR FROM ONE POSITION TO ANOTHER.</p>	<table border="1" style="width: 100%; border-collapse: collapse;"> <tr> <td style="width: 20px; text-align: center;">J</td> <td>CLIP</td> </tr> <tr> <td style="width: 20px; text-align: center;">K</td> <td>FLANGE</td> </tr> </table> <p>WARNING: FAILURE TO INSTALL THUMB KNOBS WILL CAUSE YOUR SEAT TO BE LOOSE.</p>	J	CLIP	K	FLANGE
J	CLIP				
K	FLANGE				
 <p>6. WITH YOUR HAND ON THE SEAT, PUSH DOWN AND BACK TO RETURN THE CHAIR TO TV POSITION. DO NOT REMOVE THE SEAT.</p>	 <p>7. WITH YOUR OPPOSITE HAND, CLOSE THE LEG REST. THIS RETURNS THE CHAIR TO THE UPRIGHT POSITION.</p>				
<p>THIS ILLUSTRATION SHOWS HOW TO RETURN A RECLINER-TRANSPORTER IN UPRIGHT POSITION.</p>					
 <p>8. WITH CHAIR IN UPRIGHT POSITON, LIFT THE SEAT FRONT SLIGHTLY, AND SLIDE THE SEAT OFF THE MECHANISM. INSTALL THE THUMB KNOBS ON THE SEAT FOR SAFEKEEPING. SEE DETAIL TO RIGHT TO REPLACE.</p>	<div style="display: flex; align-items: flex-start;">  <div style="margin-left: 10px;"> <p>LIFT THE FRONT OF THE SEAT UNTIL BOLT CLEARS THE MECHANISM. SLIDE THE SEAT OFF.</p> </div> </div> <div style="display: flex; align-items: flex-start; margin-top: 10px;">  <div style="margin-left: 10px;"> <p>TO REPLACE THE SEAT, REMOVE THE THUMB KNOBS. SET THE SEAT ON THE MECHANISM WITH THE CLIP ON EACH SIDE OF THE SEAT UNDER THE FLANGE ON THE MECHANISM. SLIDE THE SEAT BACK. LIFT THE SEAT AND PUT THE BOLT THRU THE SLOT IN THE FLANGE.</p> <p>REPEAT STEPS 2 - 5 TO SECURE THE SEAT WITH BOTH THUMB KNOBS.</p> </div> </div>				
<p>THIS ILLUSTRATION SHOWS HOW TO REMOVE AND REPLACE THE SEAT.</p>					

Note: Some components may have a different appearance than shown in the picture due to multiple models of chairs. The serial number of the chair informs Customer Experience of the proper components for that chair.

GENERAL MAINTENANCE AND CARE (continued)

Chairs with Heat or Heat/Massage

Please reference the beginning of this section, General Maintenance and Care. Please wipe up all spills as soon after they happen as possible. Use caution when cleaning around any of the cord connections in the power components.

Make sure to wipe all moisture out of switch area after all cleaning.

CAUTION: Heat or heat/massage components are fixed to the inside of the removable seat cushion. The seat can be slid forward as described on a previous diagram BUT must be flipped up and placed in the chair. This allows the seat to be moved for access to the inside of your recliner without having to remove any components.

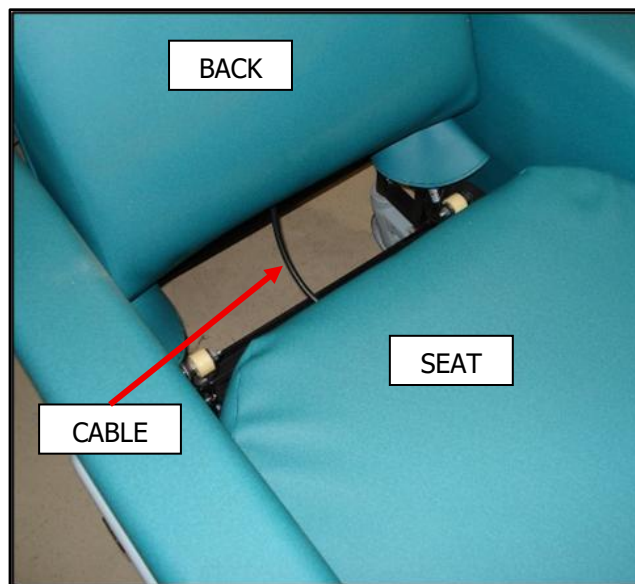

Note: Some components may have a different appearance as shown in the picture due to multiple models of chairs. The serial number of the chair informs Customer Experience of the proper components for that chair.

GENERAL MAINTENANCE AND CARE (continued)

General Cleaning Precautions

 **WARNING: NEVER mix ammonia, or a cleaner with ammonia, with bleach as dangerous compounds may result.**

 **WARNING: When solvent type cleaners are being used, care should be exercised. KEEP AWAY from fire or flame and use in a well-ventilated area.**

 **CAUTION: Treat all stains immediately to prevent it becoming a permanent stain.**

 **CAUTION: Several light applications of a cleaning agent are less harmful than a single concentrated application to remove a stain.**

 **CAUTION: Some fabric dyes, including indigo dyes commonly used in denim jeans, may migrate to the surface of the material and have the ability to create a permanent stain. This is increased by humidity and temperature and may be irreversible. To reduce the likelihood of a problem from this or any stain, clean as soon as noticed.**

 **CAUTION: Indiscriminate use of strong solvents can damage or discolor vinyl.**

 **CAUTION: DO NOT use abrasive household cleansers or steel wool.**

 **CAUTION: Residue left by cleaning agents will degrade and shorten lifespan and/or affect the product's appearance if not removed.**

 **CAUTION: DO NOT use steam cleaning or hot water to clean.**

 **CAUTION: DO NOT use an iodine-based solution or the upholstery will become stained.**

GENERAL MAINTENANCE AND CARE (continued)

General Cleaning - Upholstery

Remove excess soil with a damp non-abrasive cloth. Use a soft white cloth and solution of mild liquid soap or water based cleaner and water. Rinse all cleaning agents thoroughly with water and dry with a soft cloth.

IMPORTANT: For specific cleaning instructions, please see manufacturer's cleaning instructions.



CAUTION: DO NOT use cleaners marked "for hard non-porous surfaces only" unless approved by the upholstery manufacturer. Such use may cause surface deterioration.



CAUTION: Pretest any cleaning method or agent in a small hidden inconspicuous area.

Stain Removal

For best results treat all stains immediately. Remove any fluids by blotting with a clean, colorfast, absorbent cloth. Flush stain with water and dry with clean cloth. Remove as much of the solid or semi-solid substances as possible using a flat object. After removal, vacuum thoroughly using the proper attachments before cleaning with an agent. Clean stains or spots from the edge of the stain working towards the center.

General Cleaning - Plastic Table Tops

It is always easier to clean the table immediately after a spill. When the residue from a spill has dried on the table, a soft bristle brush may be used to help bring it back into solution. Rinse the surface with clean water. For residue that is not readily soluble in bleach and water, try hot water and dish washing liquid. Rinse and use absorbent material to remove as much liquid as possible. You may also try rubbing alcohol, applying a small amount of alcohol with a cloth, rubbing the dried-on residue. It may take several applications to dissolve the residue.



CAUTION: DO NOT use strong solvents such as Picrin® or Goof-Off®. They will damage your table top.



CAUTION: Compounds that are safe to use on the vinyl surfaces of your chair may not be appropriate for cleaning your table top.

General Infection Control

A solution of up to 10% bleach and water may be used. After using bleach solution be sure to rinse area with a soft cloth moistened with clear water and let dry. Bleach solutions not completely removed can fade the material. **NEVER** use bleach in full strength to clean these materials. Information in regard to the strength of bleach solution from the vinyl manufacturer is meant to establish an upper limit beyond which damage might occur.

WARRANTY PROCEDURE

File a Warranty Claim

Calling Customer Experience may institute a warranty claim. At that time, you will be asked to provide:

- Your name and facility name
- Your phone and email address
- **The serial number of your product**, and
- The nature of your problem

Having the above information available at the time that you call will speed the process. In order to provide prompt accurate service, it may be necessary to request further information about the chair function to accurately define the problem.

Warranty Does Not Apply If

- Repairs have been made that were not authorized or under the direction of Champion Manufacturing Inc's service department.
- Required repairs are due to normal wear and tear.
- Product has been abused, improperly used or maintained.
- Alterations have been made to the chair.
- Improper cleaning agents or methods have been used.
- Repairs have been made with parts other than Genuine Champion repair parts.

Whether your claim is covered under warranty may not always be determined at the time of your call. Where the possibility of improper use exists, a determination will be made upon receipt of damaged components or product. In these cases, components or product will be shipped with the express understanding that if damage is not covered by warranty **all costs are the responsibility of your facility**.

Due to ongoing product enhancements, key components and other service items may no longer be supported outside of the product's lifetime.

SERVICE INFORMATION

The mission of the Service Department is to get your chair up and running as quickly as possible. It is critical that the Service Department know what product you have, and exactly what is wrong with the product. If you have questions or problems, you should never hesitate to call for assistance: 800-237-3377.

The most timely and cost-effective way for your chair to be repaired is for the Service Department to work with your maintenance department or equipment technician.

Determining the Problem

What is wrong with the chair should be determined by troubleshooting. The Service Department will assist you with this by asking you questions about the chair function.

Serial Number

The chair serial number identifies the precise configuration of your chair; this is critical to receiving correct components and instructions. **This number is required to process your request.**

The serial number is located in the back of the chair on the lower left side on the label entitled "Manufactured By Champion - Serial Number: xxxxxxxxxxxx".

No parts will be shipped without a Serial Number to which they will be installed.

