



Multi-Tube Vortex Mixers



Powerful Hands-Free Vortex Mixer for Efficient High-Throughput Mixing

OHAUS Multi-Tube Vortexers are ideal for hands-free, high-throughput sample processing. Interchangeable foam racks for vortexing tubes from 10 to 29 mm in diameter are available. Strong suction cup feet reduce motion and prevent sliding on the work surface for safe operation in the lab. Digital models offer exact speed control for applications that demand repeatable results. Non-digital variable speed models are an economical alternative.

Standard Features:

- Easily process up to 50 samples at one time - the Multi-Tube Vortex Mixer can be customized for your application with six different tube racks and a post- extension kit.
- The Multi-Tube Vortex Mixers feature either an easy to clean one-piece stainless steel housing that is perfect for clean rooms or a painted steel version for a more economical option.
- For challenging samples, enhance vortex action and create a more vigorous mix with the programmable pulse mode on the digital models. Adjust the pulse-on/pulse-off time interval to customize operation.

Multi-Tube Vortex Mixers

Model	VXMTAL	VXMTALB	VXMTDG	VXMTDGB
Housing	Stainless Steel / One-Piece	Painted Steel / Two-Piece	Stainless Steel / One-Piece	Painted Steel / Two-Piece
Control	Analog		Digital	
Speed Range	1200 rpm – 2400 rpm		500 rpm – 2500 rpm	
Orbit	0.1 in. / 3.6 mm			
Duty Rating	Continuous			
Capacity	10 lb / 4.5 kg			
Working Environment	39 °F – 104 °F, 20% – 85% RH*, non-condensing / 4 °C – 40 °C, 20% – 85% RH*, non-condensing			
Power	120V, 5A, 50/60Hz / 230V, 1A, 50/60Hz			
Power Consumption	100 W			
Tray Dimensions (L × W)	7.25 × 12.25 in. / 184 × 311mm			
Dimensions (W × L × H)	15.1 × 9.5 × 16 in. / 384 × 241 × 406 mm			
Net Weight	44.8 lb / 20.3 kg			

*Relative Humidity

Other Standard Features and Equipment

Detachable 3-wire cord and plug (included), foam rack for (50) 12 mm diameter tubes (included), interchangeable foam racks for vortexing tubes from 10–29 mm in diameter (ordered separately). VXMTAL and VXMTDG feature a one piece stainless steel housing, and VXMTALB and VXMTDGB feature an economical painted steel housing.

Compliance

- **Product Safety:** CAN/CSA C22.2 61010-1, CAN/CSA C22.2 61010-2-051, UL 61010-1
- **Electromagnetic Compatibility:** ICES-003 Class A, FCC Part 15 Class A
- **Compliance Marks:** TÜV SÜD

Accessories

10 mm Tube Rack, 50 Tube Capacity	30400238
12 mm Tube Rack, 50 Tube Capacity	30400239
13 mm Tube Rack, 50 Tube Capacity	30400240
16 mm Tube Rack, 50 Tube Capacity	30400241
50 mL Tube Rack, 15 Tube Capacity	30400242
25 mm Tube Rack, 28 Tube Capacity	30400243
Post Extension Kit*	30400244
Tray Pad Set - Top And Bottom.....	30400245

*Without post extension kit - tubes from 2 in - 4 in / 5.1 cm - 10.2 cm height
 With post extension kit - tubes up to 10 in / 25.4 cm height

Dimensions

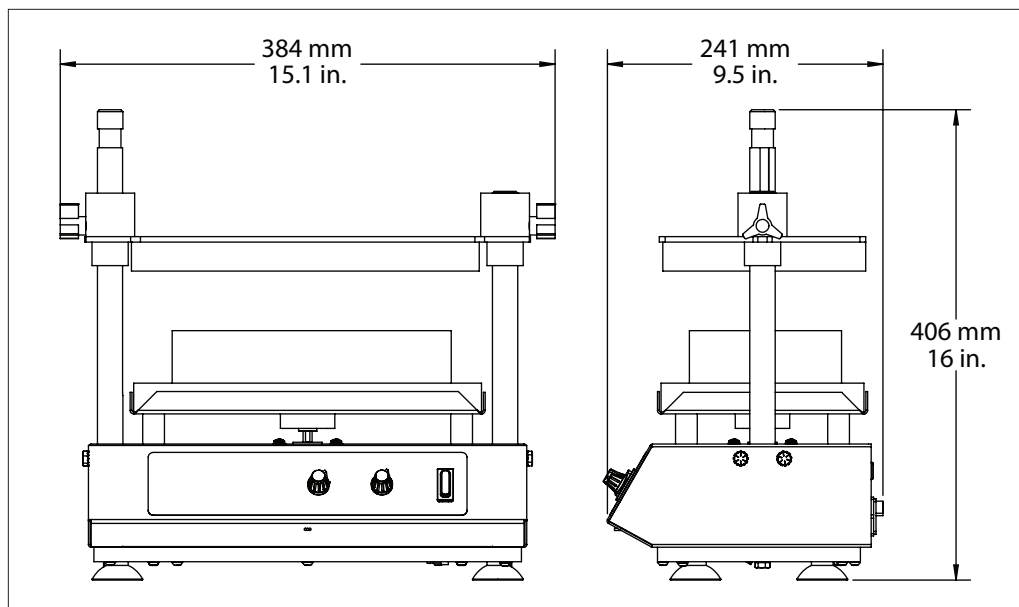

80775587_E 20240618 © Copyright OHAUS Corporation

