

DETECTO®



PEDIATRIC 
scale carts

User Guide

Introduction

Thank you for purchasing our Detecto Pediatric Scale Cart. It has been manufactured with Detecto quality and reliability.

Attention

1. Please read this User Guide before using product.
2. The correct ways to safely use this product are provided by this User Guide.
3. This User Guide lists attention points when you are using this product.
If you miss the attention points and use incorrectly, it is possible to get hurt or damage this product.

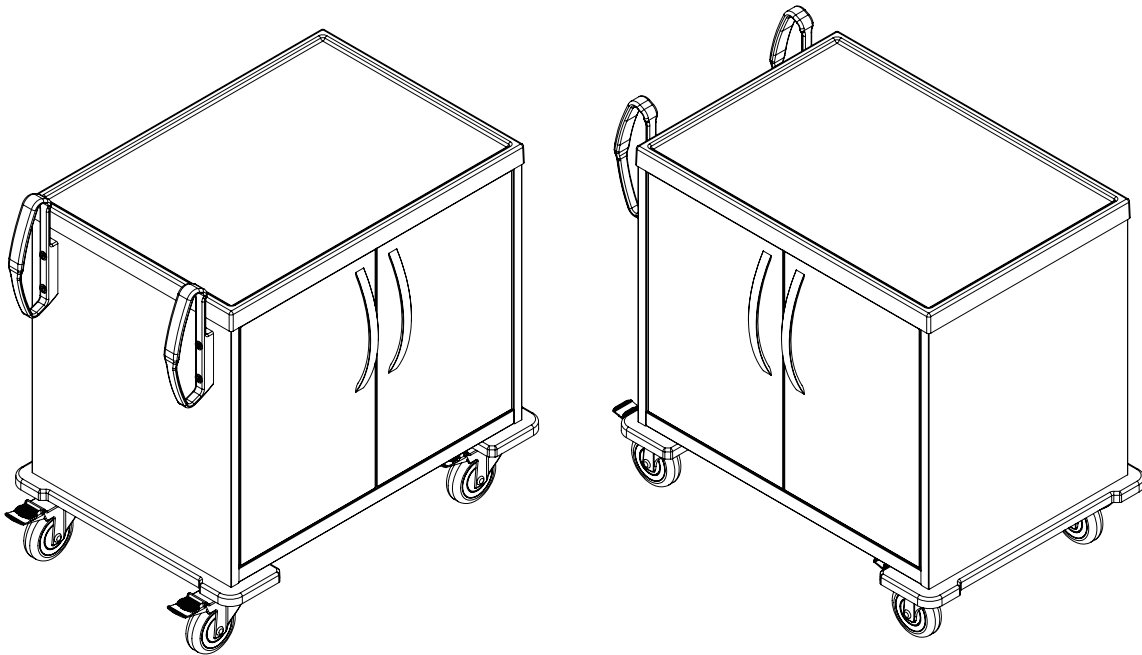

Precautions



WARNING

Incorrect use of this cart can result in serious injury to operator and/or damage to the cart.



ATTENTION



PROHIBITED

Table of Contents

Safety Precautions	1
Pediatric Scale Cart Accessories	5
Push Handle	5

Safety Precautions



WARNING

Carefully move cart and do not allow it to fall.

X

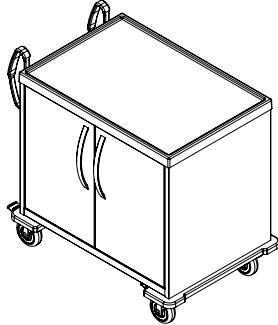

Pay attention to the front of cart when moving forward.

!

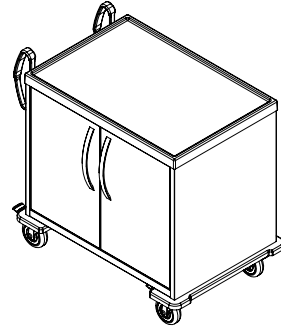

Pay attention to direction of cart when moving it.

!

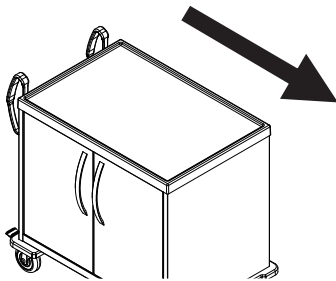

Do not force cart to turn when caster brake is locked.

X

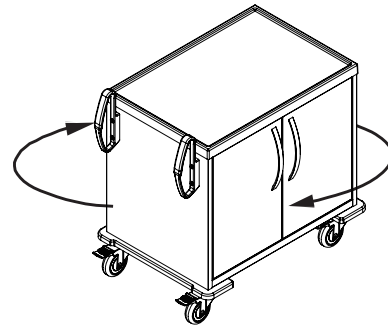

Do not use cart on stairs.

X

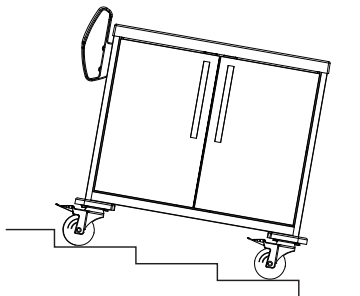

Attention!! Remember to lock caster brakes when you stop or park cart.

!

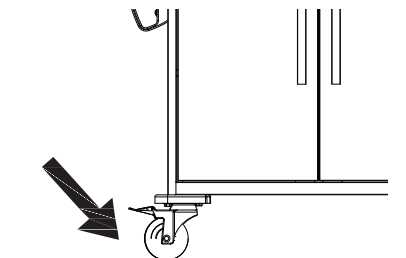

Safety Precautions



WARNING

Do not move cart by pushing or pulling on accessory parts.

X

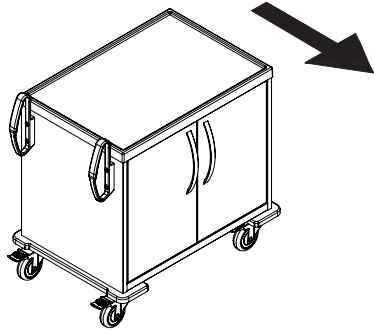

Do not move cart without unlocking caster brakes.

X

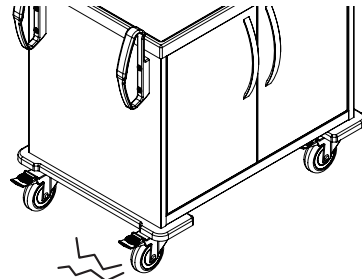

Attention!! Remember to tighten screws when you install parts and accessories.

!

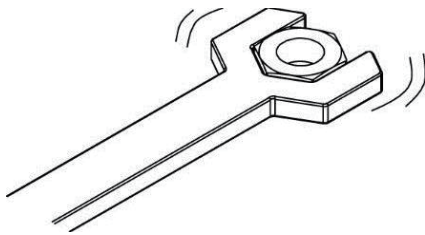

Do not overload top of cart.

X

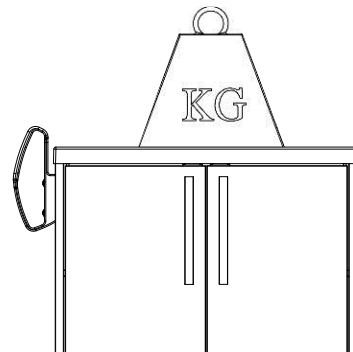

Safety Precautions



WARNING

Do not park cart on an inclined or un-level floor.

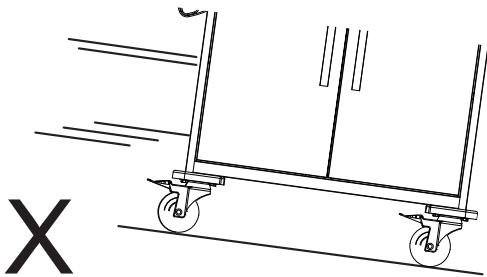

Attention!! Park cart on flat level floor.

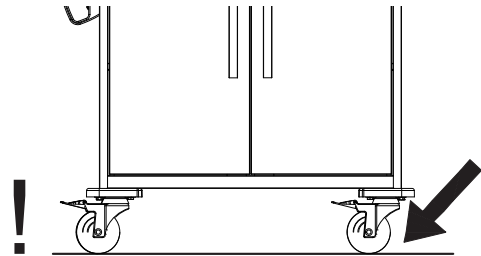

Do not strike cart with objects (ex:Hammer).

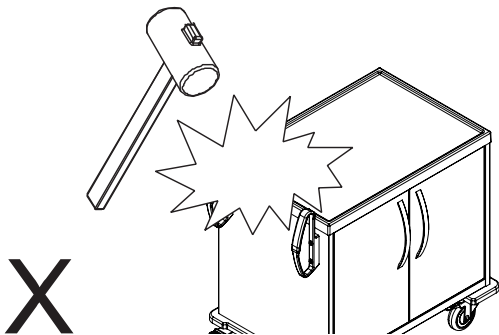

Do not put high temperature products on cart.

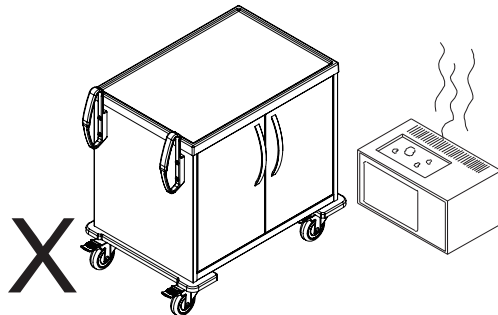

Safety Precautions



WARNING

Do not expose cart or accessories to direct sunlight.

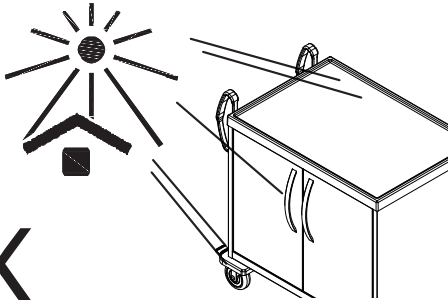

Keep volatile compounds away from cart and accessories.

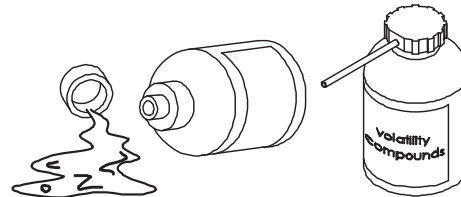

Keep chemical dissolvent and polishing compounds away from cart and accessories.

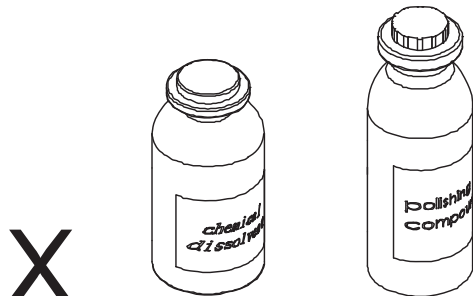

Do not use a hard scrubber to scrape or polish cart.

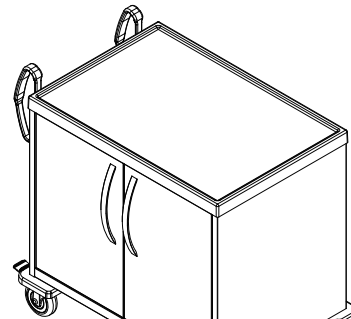

! It is recommended to use 75% alcohol or a neutral detergent to clean cart.

Pediatric Scale Cart Accessories

Push Handle

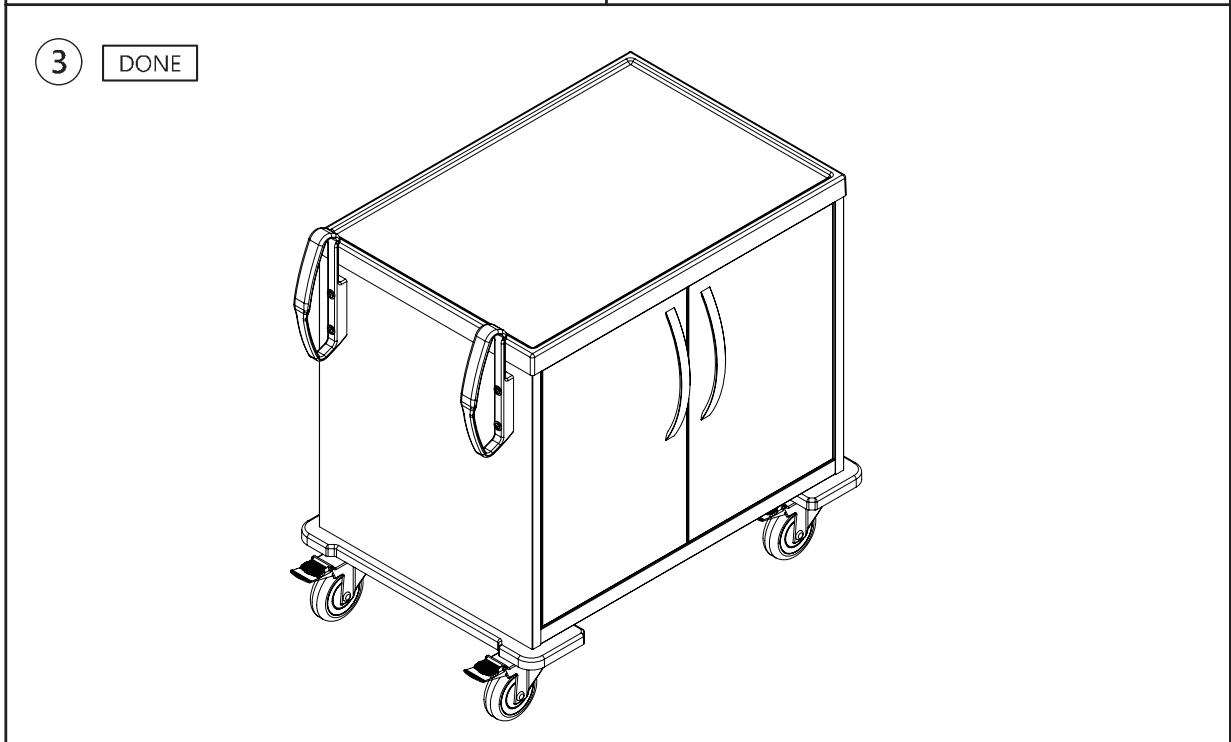
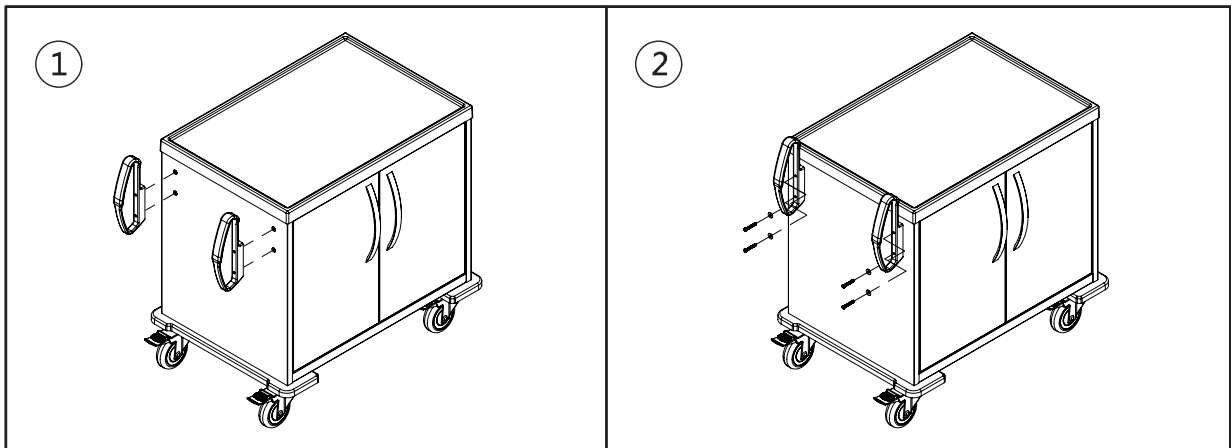
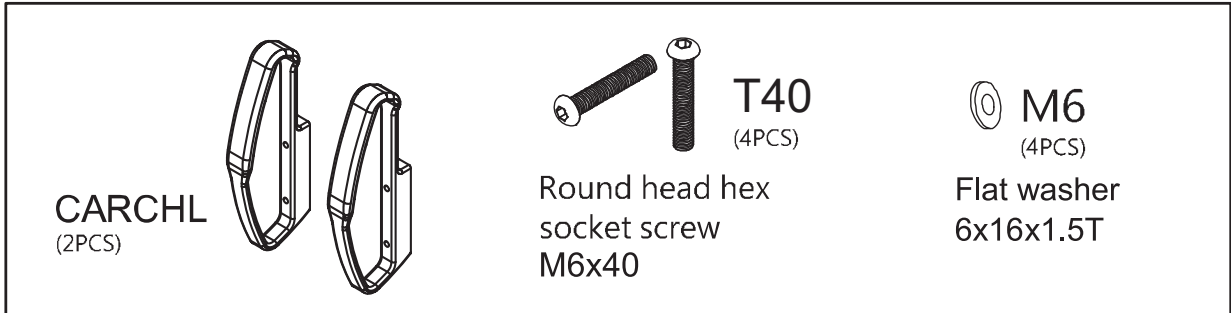

DETECTO PEDIATRIC SCALE CARTS STATEMENT OF LIMITED WARRANTY

DETECTO warrants its Scale Carts and Cart Accessories to be free from defects in material and workmanship as follows:

DETECTO warrants to the original purchaser only that it will repair or replace any part of the medical cart which is defective in material or workmanship for a period of **twelve (12) years from date of shipment**. Scale carts accessories (such as IV poles, waste bins, catheter holders, bin organizers, etc.) are warranted for a period of **two (2) years from the date of shipment**.

DETECTO shall be the sole judge of what constitutes a defect.

During the first ninety (90) days, DETECTO may choose to replace the product at no charge to the buyer upon inspection of the returned item.

After the first ninety (90) days, upon inspection of the returned item, DETECTO will repair or replace it with a refurbished product. The customer is responsible for paying for the freight both ways.

This warranty does not include replacement of expendable or consumable parts, or parts which have deteriorated or been damaged due to wear including but not limited to plastic parts such as tops, drawer rollers and slides, wheels, locks and hinges. Nor does it apply to damage caused by accident, misuse, abuse, overloading, theft, lightning, fire, water or acts of God, or due to extended storage or exposure.

This warranty does not apply to normal maintenance service, which is the responsibility of the purchaser.

DETECTO may require the product to be returned to the factory; item(s) must be properly packed and shipping charges prepaid. A Return Authorization number must be obtained for all returns and marked on the outside of all returned packages. DETECTO accepts no responsibility for items lost or damaged in transit, received without prior authorization or without proper markings and documentation.

Conditions Which Void Limited Warranty

This warranty shall not apply to equipment which:

- A.) Has not been properly assembled.
- B.) Has been tampered with, defaced, mishandled or has had repairs and modifications not authorized by DETECTO.
- C.) Has had serial number altered, defaced, or removed.

Freight Carrier Damage

Claims for equipment damaged in transit must be referred to the freight carrier in accordance with freight carrier regulations.

This warranty sets forth the extent of our liability for breach of any warranty or deficiency in connection with the sale or use of the product. DETECTO will not be liable for incidental or consequential damages of any nature arising from the use of any DETECTO product, defective or not, including but not limited to, loss of profit, delays or expenses, whether based on tort or contract. DETECTO reserves the right to incorporate improvements in material and design without notice and is not obligated to incorporate improvements in equipment previously manufactured.

The foregoing is in lieu of all other warranties, express or implied including any warranty that extends beyond the description of the product including any warranty of merchantability or fitness for a particular purpose. This warranty covers only those DETECTO products installed in the forty-eight (48) contiguous continental United States.

