

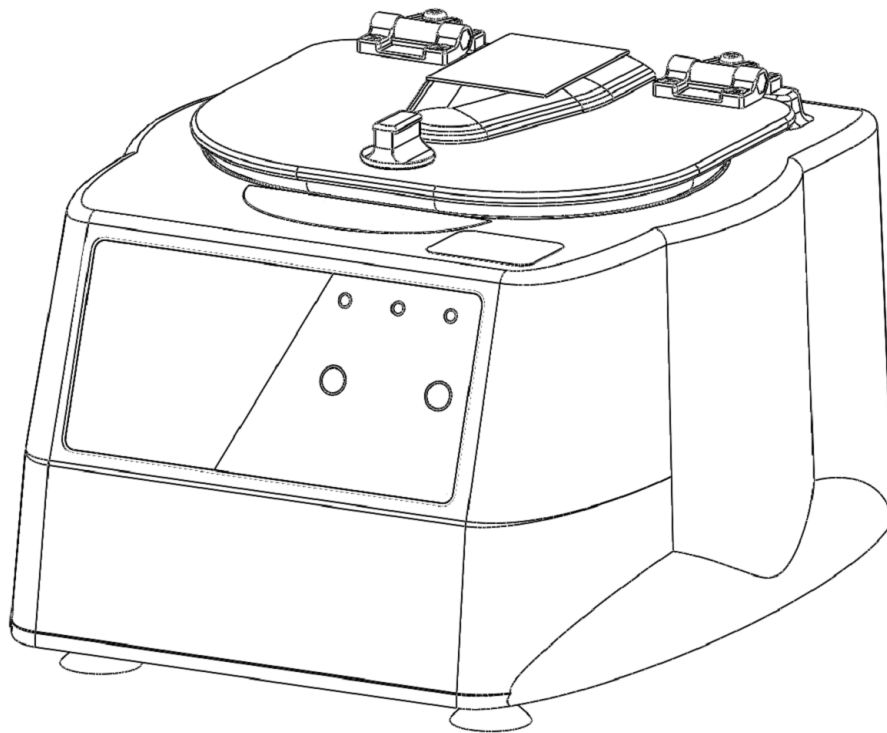

***Drucker Diagnostics***  
*Innovative Solutions for a Healthier World*

# **Service Manual**

## **Model 642E Centrifuge**



# CONTENTS

1	PREFACE.....	3
2	GENERAL DESCRIPTION OF MAJOR COMPONENTS .....	3
3	WARRANTY INFORMATION .....	3
4	SPECIFICATIONS.....	3
5	TROUBLESHOOTING .....	4
6	SERVICE INSTRUCTIONS.....	5
7	WIRING DIAGRAM .....	10
8	FINAL CENTRIFUGE ASSEMBLY .....	11
9	CABINET ASSEMBLY .....	12
10	LOWER ASSEMBLY .....	13
11	BASE ASSEMBLY.....	14
12	MOTOR ASSEMBLY .....	15
13	REVISION HISTORY.....	16

## 1 PREFACE

- 1.1 The purpose of this manual is to provide the service technician with information for troubleshooting, testing, and repair of laboratory centrifuge model 642E. Only qualified technically trained personnel should attempt any of the servicing described in this document. Failure to follow the procedures in this document may result in personal injury or instrument damage. The Drucker Company will not be held liable for any injury or damage as a result of improper servicing.
- 1.2 Information contained within this manual is subject to change without notice.

## 2 GENERAL DESCRIPTION OF MAJOR COMPONENTS

- 2.1 Motor: Permanent Split Capacitor AC Motor
- 2.2 Printed Circuit Board: The PCB is the microcontroller based control center of the centrifuge. All control signals are generated in the PCB.
- 2.3 Lid Locking Tray Assembly: The lid tray assembly contains a solenoid and limit switch that are used to determine the state of the lid (Open or Closed) and to keep the lid locked during centrifugation cycles.
- 2.4 Rotor: The centrifuge rotor is the main component that spins in the centrifuge. The rotor is loaded with tube holders, and the samples are placed into the tube holders for processing.

## 3 WARRANTY INFORMATION

- 3.1 The Drucker Company warrants its centrifuges to be free from defects in workmanship and parts for two years.

## 4 SPECIFICATIONS

Maximum Speed	3380 RPM
Maximum RCF	1590 xg
Maximum Capacity	6 Tubes (17 x 100mm)
Dimensions (in)	9.0 (H) x 11.0 (W) x 12.5 (L)
Environmental Operating Range	2-40 deg C
Typical Noise Level (At Maximum Speed)	< 65 dB A

Electrical Ratings	115VAC (+/- 10V)
--------------------	------------------

## 5 TROUBLESHOOTING

PROBLEM	POSSIBLE CAUSE	SOLUTION
The lid does not open.	No Power	Check line cord
	No Power	Check circuit breaker on underside of centrifuge.
	No Power	Check wall outlet
	Lid knob is ajar	Rotate the lid knob fully clockwise before pressing the 'OPEN' button
	Lid lock is active (Unlock timed out)	Press the 'OPEN' button to de-activate the lid
	Lid tray is unplugged from PCB or defective	Requires service
	PCB is damaged	Requires service
		To gain access to the rotor - Remove the 'OPEN/CLOSE' sticker and slide the lid latch lever toward the front of the centrifuge. This will unlock the lid.

PROBLEM	POSSIBLE CAUSE	SOLUTION
Excessive vibration	Rotor improperly loaded	Load equally filled tubes symmetrically in the rotor. All carriers and/or tube holders must be present in the rotor, whether loaded, or empty.
	Debris lodged within the rotor or tube carriers	Carefully inspect all rotor pockets, tube holders and crevasses for debris.
	Centrifuge housing is loose	Requires service
	Missing/damaged feet	Requires service
	Motor failure	Requires service
	Rotor damaged	Replacement required

PROBLEM	POSSIBLE CAUSE	SOLUTION
Rotor does not spin	No Power	Check line cord
	No Power	Check circuit breaker on underside of centrifuge.
	No Power	Check wall outlet
	Lid not properly latched	Press down firmly on lid and rotate lid knob clockwise until the 'LATCHED' light illuminates.
	Internal connection failure	Requires service
	PCB failure	Requires service
Motor Failure	Requires service	

PROBLEM	POSSIBLE CAUSE	SOLUTION
Clicking noise during braking	Rotor is loose	Tighten rotor nut per section 7-2

PROBLEM	POSSIBLE CAUSE	SOLUTION
Whistling noise while running	Debris in air intake / exhaust ports	Remove power before clearing debris.
	Gasket failure	Requires service
	Gasket failure	Requires service

## 6 SERVICE INSTRUCTIONS

### 6.1 Cleaning

- a) The cabinet, rotor top and accessories shall be thoroughly cleaned using soap and water, isopropyl alcohol, or a mild bleach solution.
- b) Under no circumstances should any of the following be used: Fully/Partially Halogenated Hydrocarbons, Ketones and Esters.
- c) Use of any chemicals not prescribed by the manufacturer may cause damage to the rotor and tube carriers / holders and shall not be used.

### 6.2 Removing the Rotor

- a) Use a 1/2" nut driver to loosen the center rotor screw (turn counter-clockwise).
- b) Lift the rotor straight up and out of the rotor chamber.
- c) To install the rotor, reverse steps A and B above.
- d) Take care to align the hub spines with the rotor hub.
- e) Tighten the rotor nut by hand with a 1/2" nut driver until snug. A good rule of thumb is one full thread showing above the nut is a good indicator of proper installation.

### 6.3 Maintaining the Rotor

- a) Keep the rotor clean, any corrosive materials must not be allowed contact with the rotor and should be cleaned immediately.
- b) The rotor should be checked periodically for signs of wear.
- c) Remove the rotor from service if any of the following are found: cracks, deep scratches, corrosion or discoloring.

### 6.4 Rotor Nut

- a) If the rotor screw needs to be tightened, use a 1/2" nut driver and tighten it by hand until snug.
- b) Rule of thumb: One full thread showing above the nut is a good indicator of proper installation.

### 6.5 Speed Calibration

- a) Check the centrifuge speed periodically, we recommend every two years.
- b) Important: When verifying rotor speed, make certain that all tube holders are installed in the rotor.
- c) No calibration adjustment of speed can be made, only a verification of rotor speed.

### 6.6 Line Leakage

- a) Check the centrifuge's line leakage periodically, we recommend every two years.

- b) All Drucker centrifuges currently manufactured are classified as “laboratory equipment”, per the requirements of UL 61010-1 Electrical Equipment for Measurement, Control and Laboratory Use; Part 1: General Requirements. This standard specifies that the maximum current levels between any accessible parts are as follows:
- c) In normal condition the maximum current flow between accessible parts is 0.5mA RMS for sinusoidal waveforms, 0.7mA peak for non-sinusoidal waveforms or mixed frequencies, or 2mA DC.
- d) In single fault condition the maximum current flow between accessible parts is 3.5mA RMS for sinusoidal waveforms, 5mA peak for non-sinusoidal waveforms or mixed frequencies, or 15mA DC.

#### 6.7 Ground continuity

- a) Check the centrifuge’s ground continuity periodically, we recommend every two years.
- b) Disconnect the manufacturer’s supplied power cord from the power supply.
- c) Measure the resistance between the ground tab of the line cord and an exposed, clean, unpainted metal surface contiguous to the chassis main frame.
- d) The maximum acceptable ground resistance is 0.1 Ohms.

#### 6.8 Removing the Cabinet (Upper Housing)

- a) There are six screws that fasten the centrifuge cabinet to the base.
- b) Begin by unplugging the centrifuge, and waiting 10 minutes for internal voltages to dissipate.
- c) Use a #2 Phillips screwdriver to remove the cabinet screws (two on left and right sides, two in the rear)
- d) The centrifuge control panel is attached to the base internally with cable harnesses. Be careful not to stress the cables when removing the cabinet.
- e) Stand directly in front of the centrifuge and lift the cabinet straight up and off the base, setting it down on its right side.
- f) Gently remove the combination power supply / motor harness from the PCB.

#### 6.9 Replacing the Lid Tray Assembly

- a) The lid tray assembly is accessible once the cabinet has been removed.
- b) Gently remove the lid tray wire harness from the PCB.
- c) The lid tray assembly is held in place with two #6 Nylok nuts. Use a 5/16” nut driver to remove the nuts. The tray will slide off the threaded studs.
- d) Early models used a plastic spacer between the tray assembly and the metal cabinet. A spacer is no longer needed. **IMPORTANT: Remove any plastic spacer that may be present.**

- e) To install the lid tray, slide it onto the studs, and secure it with two #6 Nylok nuts, hand tight.
- f) Complete the installation by gently plugging the wire harness into the PCB header 'J4'. The header and connector are keyed for proper orientation.

#### 6.10 Replacing the PCB

- a) The PCB is accessible once the cabinet has been removed. Make certain that all wire harnesses have been disconnected.
- b) The PCB has capacitors that will remain charged for a period after the centrifuge is unplugged. Make certain to use standard precautions for handling potentially charged capacitors when working with the PCB.
- c) The PCB is held in place with four #6 Nylok nuts and plastic insulator washers. Use a 5/16" nut driver to remove the nuts. The PCB and washers are now free to slide off the threaded studs.
- d) Beneath the PCB are four plastic standoffs. If they are crushed, replace them before reassembly.
- e) To install the PCB, make certain that four plastic standoffs are present on the control panel studs.
- f) Slide the board onto the studs
- g) Install four plastic washers onto the studs.
- h) Important: over tightening the PCB nuts will cause malfunction – Each nut sets the height of a separate control panel switch. Too low, and they cannot be actuated, too high and they jam against the front panel label, and are always in the 'ON' state.
- i) Tighten the nuts only until the buttons on the control panel click when pressed – do not over tighten. Each nut sets the height of a separate control panel button. Tighten each nut a ¼ turn in succession, trying each corresponding button as you go.
- j) Once each control panel button clicks when pressed, installation is complete.

#### 6.11 Removing the motor

- a) Remove the cabinet assembly as previously described.
- b) Cut and remove all wire harness zip ties.
- c) Flip the base assembly up-side down and drill off the heads of the three exhaust air channel rivets with a 3/16" drill bit.
- d) Set the exhaust cover aside
- e) The guard bowl is held in place with six low-profile head rivets, 5/32 nominal diameter. To remove them, drill the heads off with a 3/16" drill bit.
- f) Lift the base assembly off of the guard bowl and set it aside.
- g) Flip the guard bowl.

- h) The motor is held in place with 4 #8 Nylok nuts. Remove them with an 11/32" nut driver.
- i) Slide the motor and motor gasket out of the guard bowl's motor well.

#### 6.12 Replacing the motor

- a) Make certain that new rubber washers are used on the motor mounting studs when installing a motor.
- b) Locate the seam on the inside of the guard bowl wall.
- c) Position the motor so its wires exit approx 180 deg away from the guard bowl seam.
- d) Install the motor and gasket into the guard bowl with the wire harness positioned as described above.
- e) Drive 4 #8 Nylok nuts onto the motor studs with an 11/32" nut driver.
- f) Turn the guard bowl assembly upside down with the guard bowl seam facing you.
- g) Place the base assembly (with line cord facing away from you) onto the guard bowl.
- h) **IMPORTANT: Make certain that no wires are pinched between the guard bowl and base!**
- i) **IMPORTANT: Tuck a portion of the motor wire harness into the rectangular cutout in the base. See fig 1.**



Figure 1

- j) Fasten the guard bowl to the base with six 5/32 nominal diameter, low-profile head rivets.
- k) Install the exhaust air cover with three 5/32" rivets. Make certain that the motor wire harness is contained within the cover's wire channel. See fig 2.



Fig 2

- l) Replace the zip tie removed earlier
- m) The lower assembly is complete.

### 6.13 Power Connections and Final Assembly

**IMPORTANT: These steps must be followed to avoid personal harm and to avoid damaging the PCB.**

- a) Make certain that the lower assembly is unplugged from the mains supply.
- b) Connect the motor/power connector to J5 on the PCB
- c) Carefully place the cabinet onto the base taking care not to pinch any wires between the two.
- d) Complete the assembly by replacing the six #8 screws, washers and lock washers with a #2 Phillips driver.

## 7 WIRING DIAGRAM

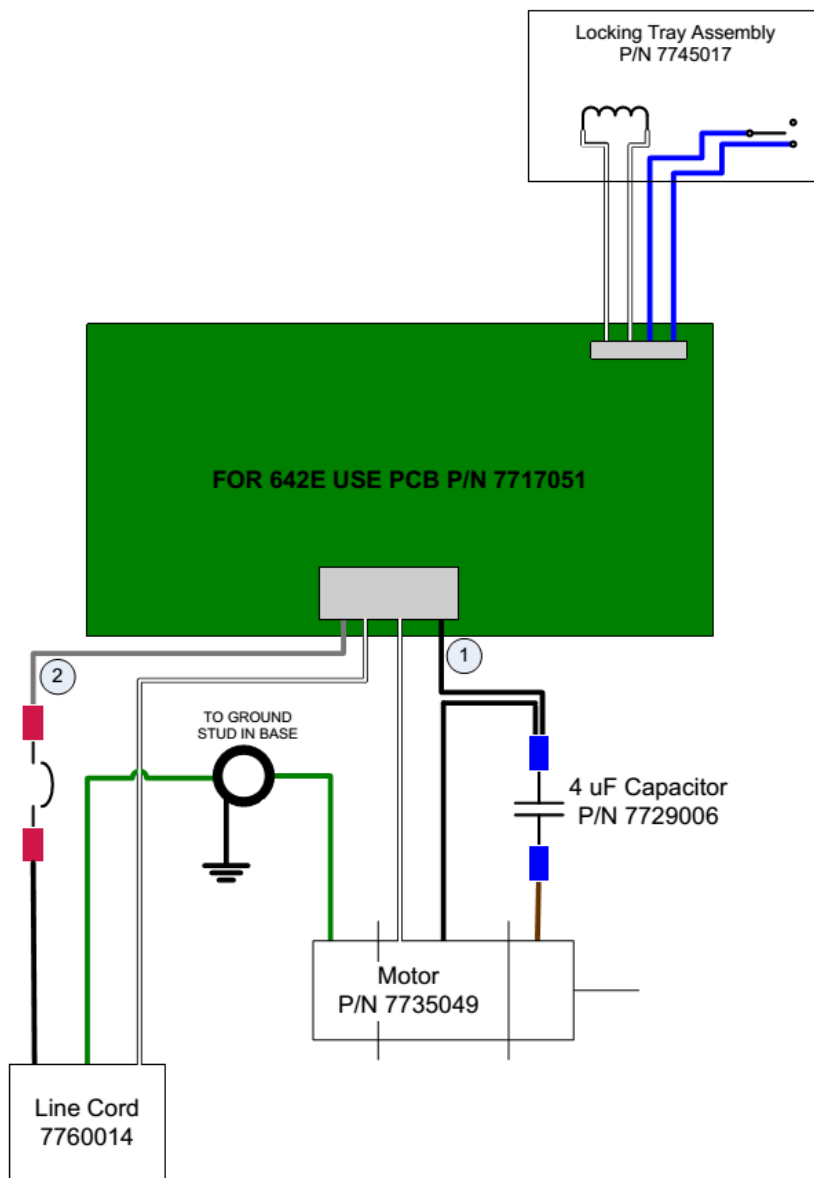

### Wire Identification: Type and Length:

1. 03-1-0005-0020 --- 18 Inch
2. 03-1-0005-0018 --- 19 Inch

### COMPONENTS:

 Disconnect, Faston,  
P/N 3081003

 Disconnect Faston 18-22  
AWG  
P/N 3081002

 Connector, IDC 4 Place  
P/N 3081006

 Connector, IDC 4 Place  
P/N 3081019

 Connector, Ring for #8 Stud  
P/N 03-1-0005-0054

 Circuit Breaker  
P/N 7751043

## 8 FINAL CENTRIFUGE ASSEMBLY

ITEM NO.	PART NUMBER	DESCRIPTION	QTY.
1	02-003-0-0074	642E LOWER ASSEMBLY	1
2	02-003-0-0075	642E CABINET ASSEMBLY	1
3	3012006	SCREW, 8-32 x 0.375, PAN HEAD PHILIPS, SILVER	3
4	3033003	WASHER #8, FLAT, SILVER	3
5	30-000015	SCREW, 6-19 X 5/16", THREAD FORMING, PAN HEAD	6
6	7724025	LABEL, CONTROL PANEL, TIMER INSTRUCTIONS	1
7	7724029	FACTORY CALIBRATION LABEL, mA	1
8	7724026	SERIAL NUMBER	1
9	7724105	UNLOCKING INSTRUCTION LABEL, SMALL	1
10	OEM SPECIFIC	FRONT PANEL LABEL	1

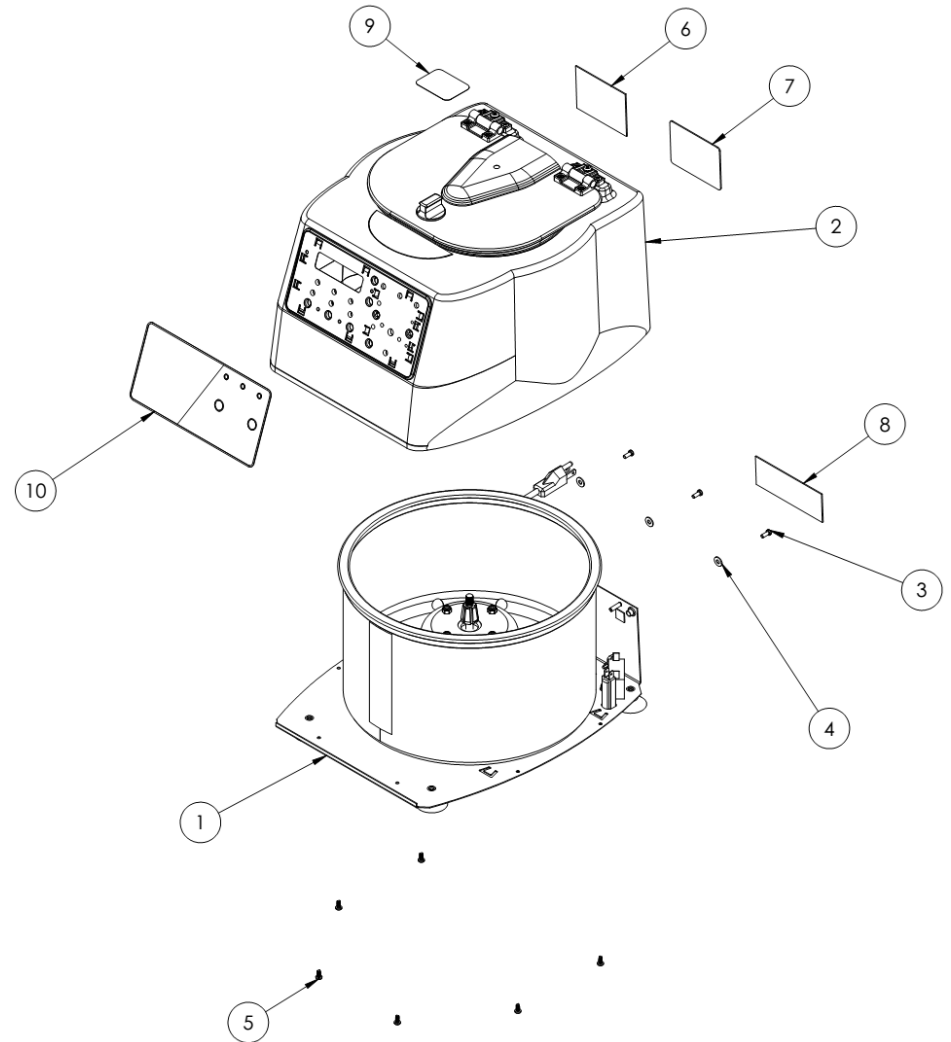

## 9 CABINET ASSEMBLY

ITEM NO.	PART NUMBER	DESCRIPTION	QTY.
1	03-1-0002-0054	614/642 PLASTIC CABINET	1
2	7732018	MOTOR WELL GASKET	1
3	02-002-1-0011	614/642 LID ASSEMBLY	1
4	7724071	FRICTION HINGE	2
5	30-000013	SCREW, 8-16 X 1/2", THREAD FORMING	4
6	3012004	SCREW, #6 x .375, PH/PHIL, SELF TAP, BLUNT, SILVER	4
7	7745017	642/755 LID TRAY ASSEMBLY	1
8	30-000014	SCREW, 8-32 X 1/2", THREAD CUTTING, FLAT-HEAD	2
9	7724023	LABEL, OPEN/CLOSE	1
11	03-1-0002-0055	614/642 FRONT PANEL	1
12	7724017	642E LABEL, STOP WARNING	1

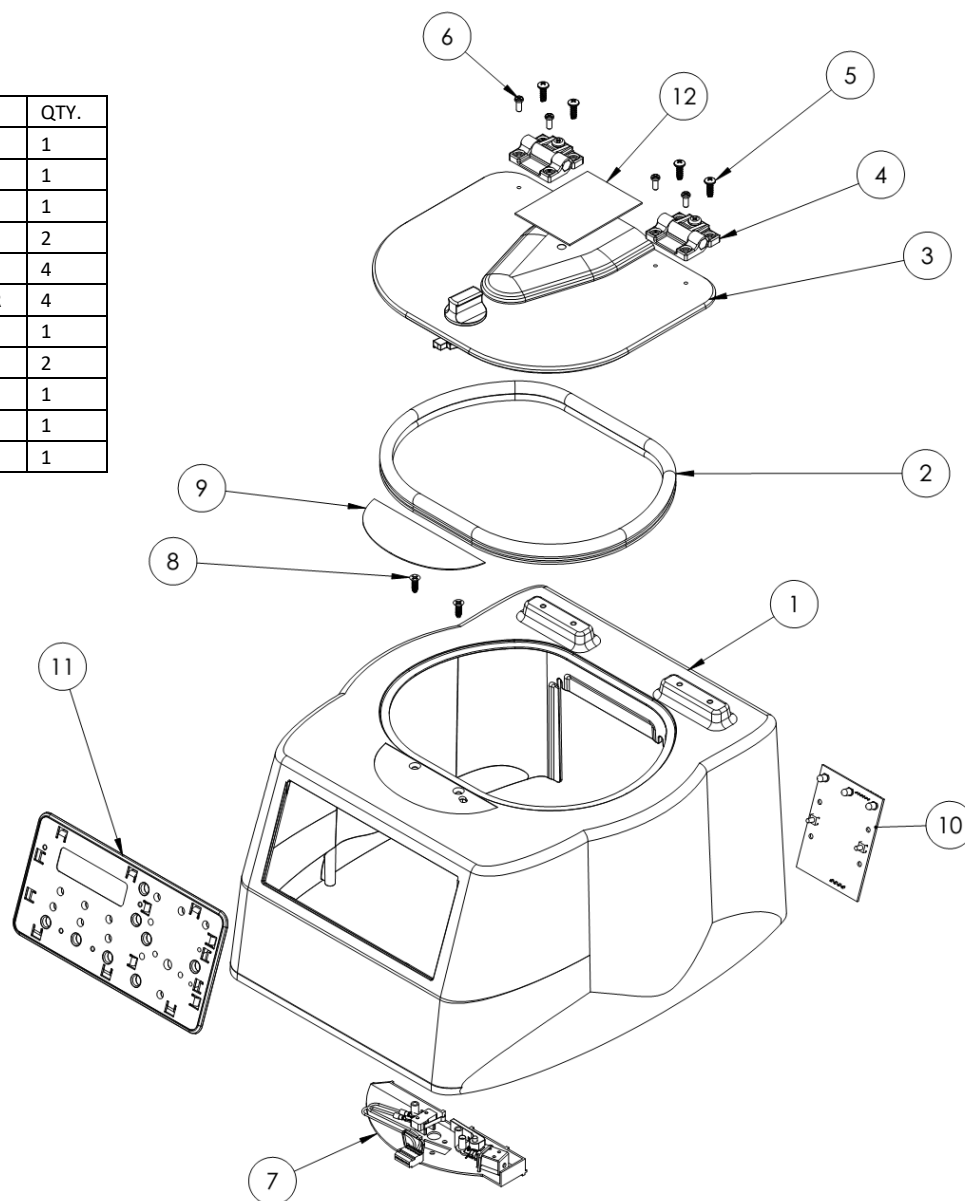

## 10 LOWER ASSEMBLY

ITEM NO.	PART NUMBER	DESCRIPTION	QTY.
1	02-003-1-0016	645 GUARD BOWL, COATED	1
2	02-005-1-0000	MOTOR ASSEMBLY	1
3	3022003	8/32 NYLOCK NUT	4
4	02-003-1-0021	642E BASE ASSEMBLY, DOMESTIC, PLASTIC CABINET	1
5	3000001	RIVET, POP, .16 X .375	9
6	7732019	642/842 GASKET, ROTOR CHAMBER	1
7	7713027	614/642/643/755 EXHAUST AIR DEFLECTOR	1
8	3094002	TIES, PLASTIC, SELF LOCKING, 4.0"	2
9	3022001	8-32 HEX NUT	1
10	7786021	642/842 HORIZONTAL ROTOR, 6 PLACE, DRILLED	1
11	3022006	NUT, 5/16-18, NYLOK	1

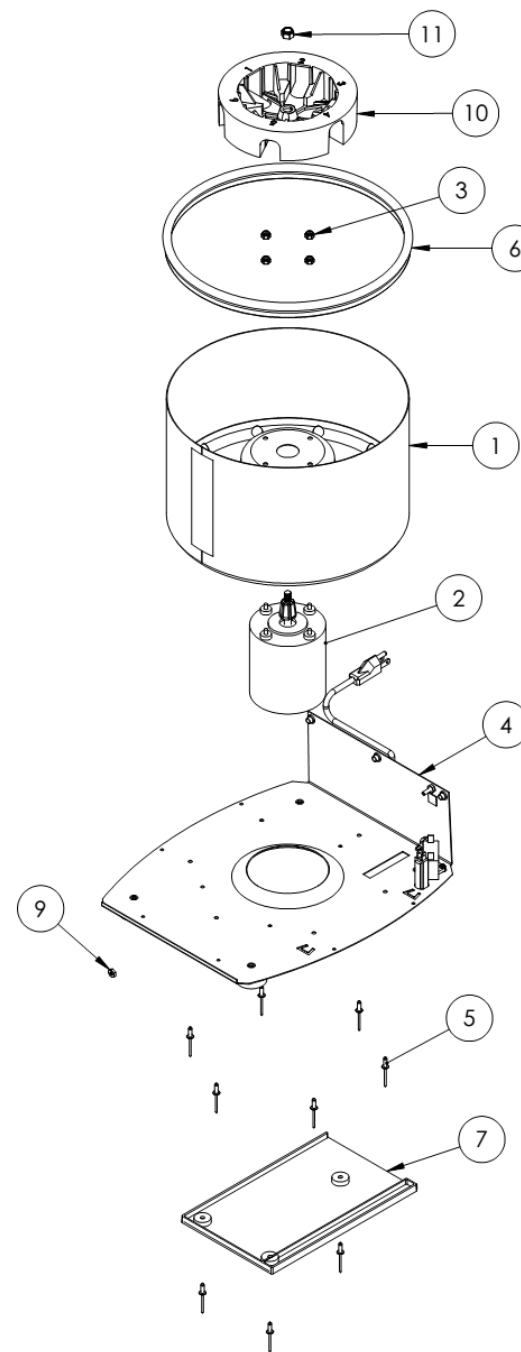

## 11 BASE ASSEMBLY

ITEM NO.	PART NUMBER	DESCRIPTION	QTY.
1	7717074	642/614 BASE, DOMESTIC	1
2	03-1-0005-0055	#8 PEM STUD, 5/8 LONG, PEM #FH832-10	1
3	3023001	NUT INSERT, 8-32 THREAD	8
4	7724037	614/642 #8-32 SUCTION FOOT	4
5	7760002	LINE CORD, TYPE B	1
6	3000005	STRAIN RELIEF, LINE CORD	1
7	7751043	BREAKER, 4A	1
8	7729006	642 CAPACITOR, MOTOR, 4 MICROFARAD	1
9	3012007	SCREW, PHILLIPS, 8-32, 0.50 LONG	1
10	7724002	LABEL, GROUND	1
11	3033012	#8 INTERNAL TOOTH WASHER	1
12	3022001	8-32 HEX NUT	1

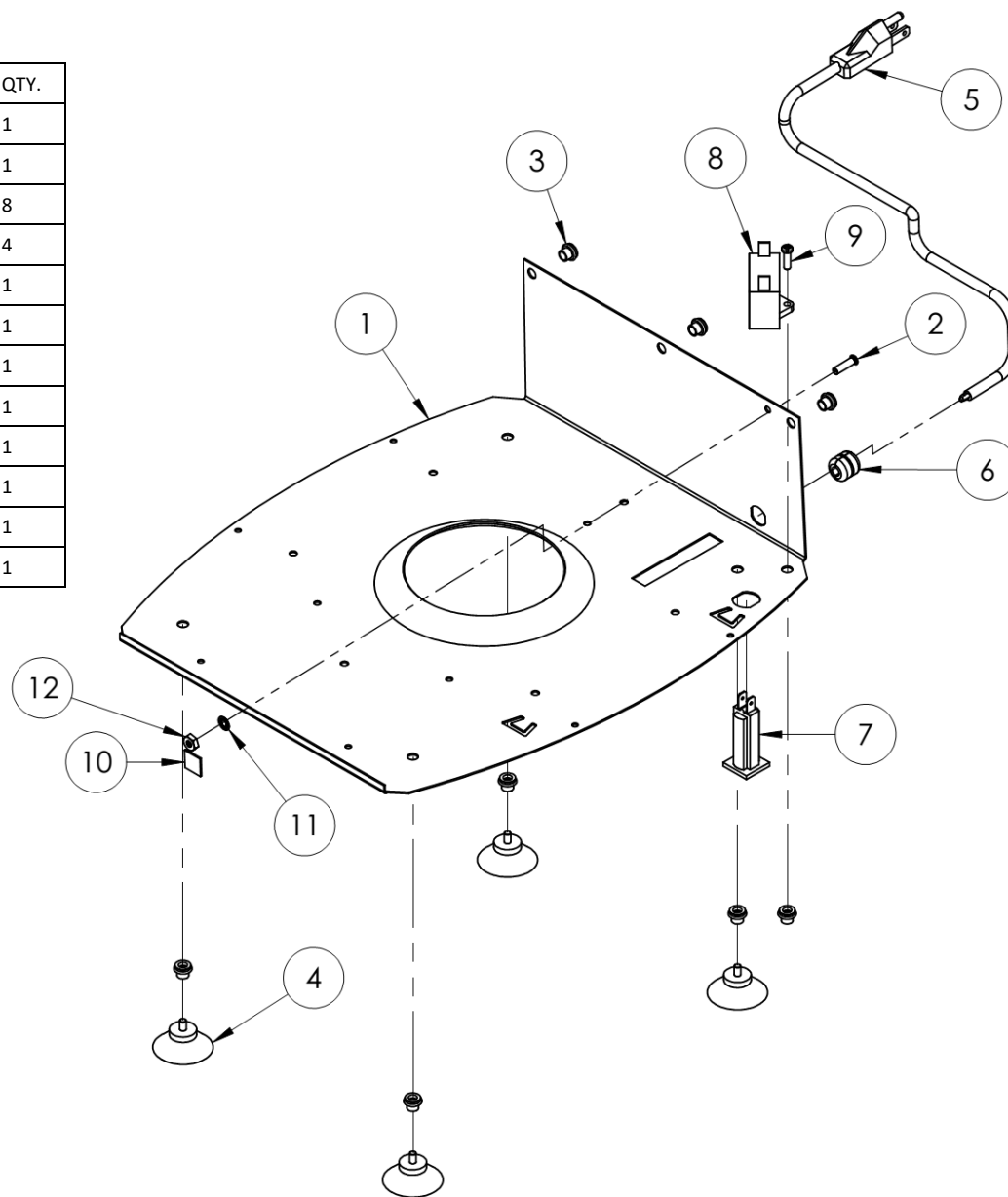

## 12 MOTOR ASSEMBLY

ITEM NO.	PART NUMBER	DESCRIPTION	QTY.
1	7735049	642 PSC Motor / 115 VAC	1
2	3062001	PIN, ROLL, 642 MOTOR DRIVE, .010 x 0.625	1
3	7786028	642/643 TAPERED ROTOR HUB	1
4	7728103	614/642 Motor Ring	1
5	3003003	WASHER, RUBBER, MOTOR MOUNT 0.175 x 0.5 OD x 0.18	4
6	3081003	DISCONNECT, 0.18", FEMALE	2
7	03-1-0005-0000	WIRE, BLACK	1

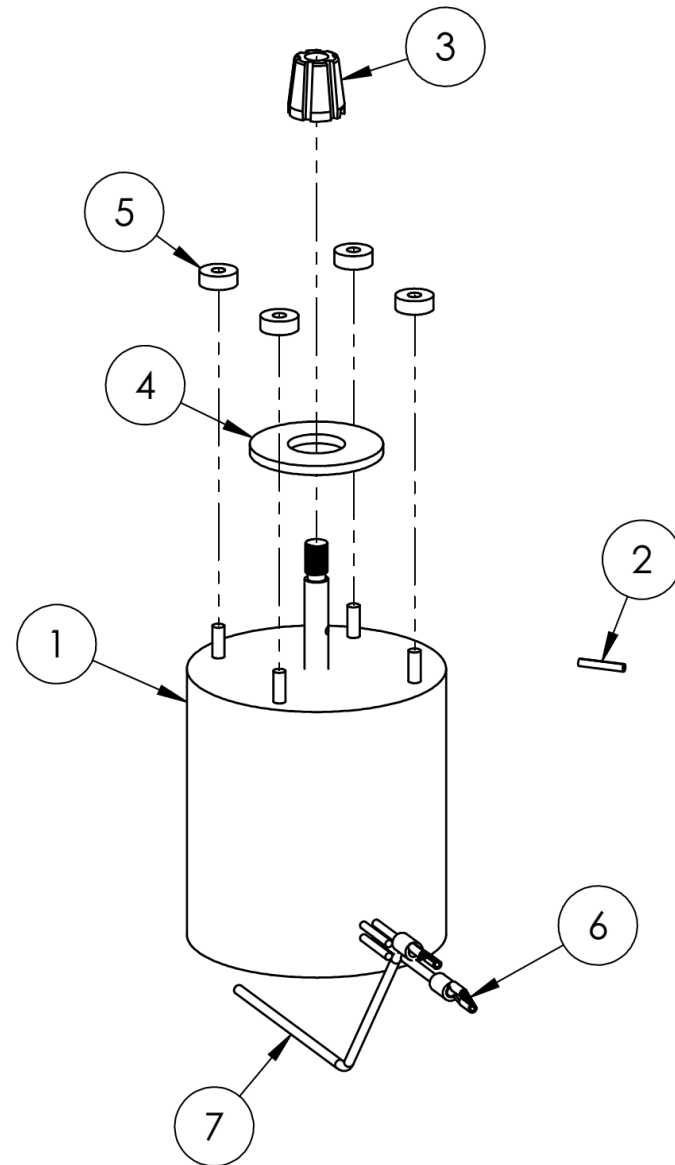

**13 REVISION HISTORY**

<b>Revision #</b>	<b>Date</b>	<b>Details of Change</b>
Original	07/07/2013	Original Issue - DR-2958.