

36 INCHES WIDE

SB-1150

BARIATRIC WHEELCHAIR SCALE

The Summit™ SB-1150 bariatric wheelchair scale provides exceptional performance in environments where typical wheelchair scales are not large enough to meet patient needs. With its large platform and easy-access ramp, the heavy-duty Summit SB-1150 accommodates wheelchairs without sacrificing safety. The scale and ramp are equipped with a nonskid rubber surface and raised guide rails. Convenient keypad tare reduces errors and increases efficiency.

FEATURES

- Large LCD display
- Antimicrobial keypad
- Heavy-duty mild steel construction
- Single ramp
- Metal nonslip platform
- Motiontrap™ movement compensation technology
- Unit of measure toggle or locking
- EMR capable
- Serial and USB data communication ports
- Bluetooth® BLE 4.0 available, part number selectable
- Tare function
- Hold function
- BMI (body mass index) function
- Factory calibrated

SPECIFICATIONS

Capacity:

1,000 × 0.2 lb (450 × 0.1 kg)

Platform Dimensions:

(L × W × H)

36.0 × 36.0 × 4.0 in

Ramp Dimensions:

(L × W × H)

36.0 × 28.5 × 4.0 in

Power:

9 VDC, provided by six AA alkaline batteries (included) or AC adapter (optional)

Battery Type:

Six AA alkaline (included)

Battery Use:

25 hours continuous use with batteries
Automatic power-off can be configured

Cable Length:

10 ft (3.1 m) cable between scale base and indicator

Display:

5-digit LCD display, 0.75 in (1.9 cm) digit height

Temperature:

Operating:
50 °F to 104 °F (10 °C to 40 °C)

Warranty:

Two-year limited

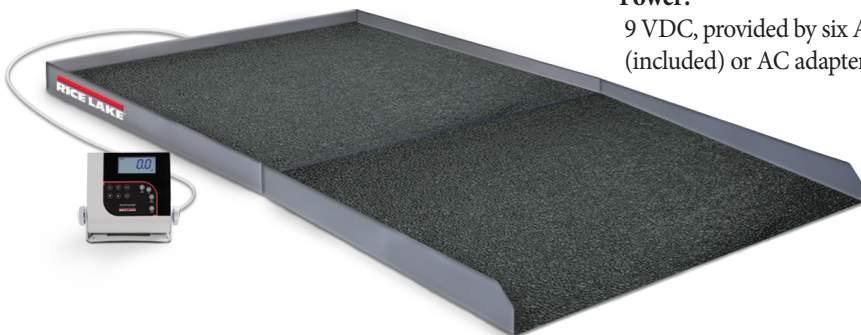



WHEELCHAIR SCALE

MODEL	CAPACITY	COMMUNICATION	PART #
SB-1150	1,000 × 0.2lb (450 × 0.1 kg)	USB	150706
SB-1150BLE	1,000 × 0.2lb (450 × 0.1 kg)	Bluetooth® BLE 4.0	205977

OPTIONS

DESCRIPTION	PART #
9 VDC adapter, 120 V/230 V auto switching*	133077
9 VDC adapter, 230 V**	102508
Epson TM-U220 tape printer	81076
Cable, RS232 scale to printer, 6 ft, 25-pin D-Sub (male) to RJ45	186830

*NEMA 1-15 Plug  **CEE 7/16 Plug 

SHIPPING WEIGHT

MODEL #	PART #	L (IN)	W (IN)	H (IN)	PACKAGE WGT. (LB)	DIM WGT. (LB)	SHIPPING WGT. (LB)
SB-1150	150706	49	48	24	363	407	407
SB-1150BLE	205977	49	48	24	363	407	407

*Pallet weight and dimensions are included in shipping weights

DIMENSIONS

	INCHES	CENTIMETERS		INCHES	CENTIMETERS
A	36.00	91.4	D	36.00	91.4
B	36.00	91.4	E	4.00	10.2
C	28.50	72.4	F	1.00	2.5

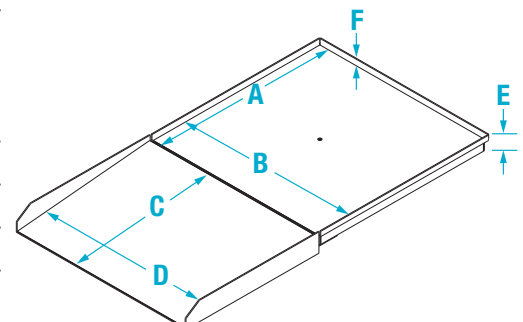

MEDICAL SCALES

Bariatric/Wheelchair Scale

Beam and Column Assembly



Bariatric/Wheelchair scale
Model SB-1150

Part Number/Price

Ref#	Part#	Description	Price
1	18756	Foot	Consult
2	21507	Load cell	Consult
3	30532	Load cell bolts	Consult
4	73428	Junction box	Consult
	106953	Cable, junction box to indicator	Consult
	100719	RS-232 serial cable	Consult

Note: See page 214 for indicator parts
(See Diagram Wheelchair-F)

Medical Scales

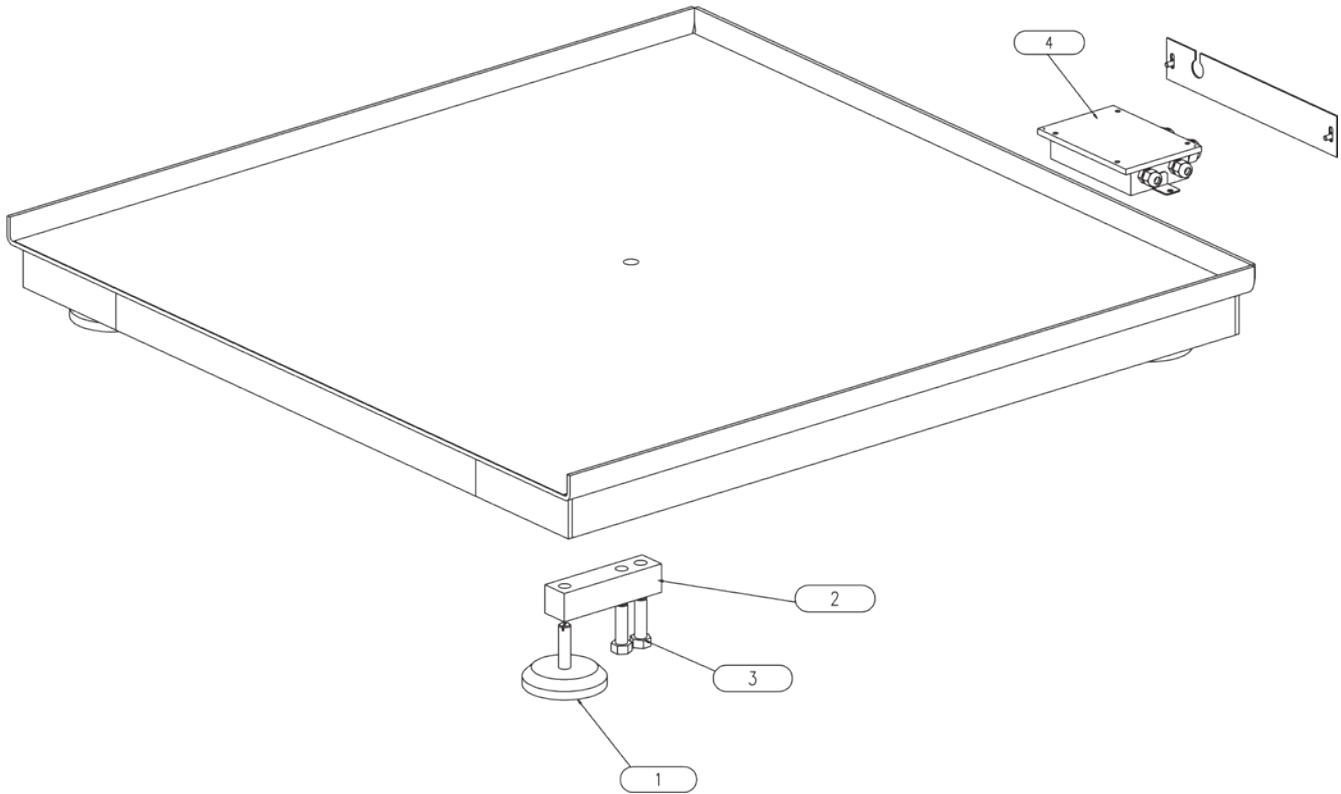

Wheelchair-F

MEDICAL SCALES

Medical Indicator, Titanium



Part Number/Price

Ref#	Part#	Description	Price
	131583	Indicator	Consult
10	164239	Front, 150 indicator kit	Consult
20	164240	Hardware	Consult
30	164241	Circuit	Consult
	204810	Circuit with Bluetooth 2.0	Consult
	204811	Circuit with BLE	Consult
40	164242	Back panel	Consult
50	164243	Table	Consult
60	164247	Back cover	Consult
70	164248	Cover	Consult
	133077	Power supply, A/C adapter	Consult

Medical Scales

