



OPERATING INSTRUCTIONS AND SERVICE MANUAL



classic, ascent & ascent II SERIES

MEDICAL RECLINER/TRANSPORTER

CONTENTS

<u>ITEM</u>	<u>PAGE</u>
Contents	1
In-Service Information	2
Special notes	3
Chair capacity information	4
Receiving new chairs	5
New chair inspection	5
To report damage	5
Return authorization	5
Storage	5
In-service procedures	6
Operating instructions	7-11
For safe recliner operation	7
Champion recliner operation poster	8
Chair positions (Upright, TV and Full Recline)	9
Trendelenburg operation	10-12
Setting the Trendelenburg feature poster	12
Operation of the swing arms (if equipped)	13
Proper use of foot tray	14
Chair options and accessories	14-16
Use of IV pole	16
General maintenance and care of chairs	17-22
Use of Quick release seat feature	18,19
General Safety for Chairs with Powered Options	20
General Cleaning Precautions	21
General cleaning – upholstery	22
General Cleaning – plastic table tops	22
General Infection control	22
Warranty procedure	23
Service information	24
Parts identification	24
Service Parts Form	25
Medical recliner schematics	26-30
Arm, table, mech. w/ upholstery (fixed arm series only)	26
Arm, table, base w/ upholstery (swing arm series only)	27
Back frame and mechanism	28
Base explosion	29
Parts listing	30
Appendix A	31,32
Actuation adjustment	32
Appendix B - Heated and Heat/Massage Recliners	33-37
Heated Recliner General Information	33
Chair specifications	34
Receiving new chairs	34
Heater operation	35-37
Massage operation	38
Maintenance	39
Heat and Heat/Massage chair parts view	40



In-Service Information

It is very important to Champion that our customers review all the materials in the in-service package they receive.

By reviewing the in-service materials provided, you increase the useful life of the products by helping to prevent their improper use, which may lead to premature damage and wear. You are also helping to validate your warranty, as warranties cover material and workmanship failures, not misuse or abuse. Use these in-service tools for new employees and as a "refresher" for current employees.

The following resources are available for you to assist your staff and patients in operating the chairs properly.

Field Sales Reps
In House Sales Reps
Network of Service Technicians
In House Service Team

You should receive an Operator's Manual on CD with each shipment of chairs you receive from Champion. If you would like information on any of these additional resources, please contact Champion's customer service department at 800-998-5018.



NOTE: Not all chair functions, options and/or accessories are covered in the CD.

NOTE: The information contained in this document is subject to change without notice.

WELCOME!

Champion Manufacturing, Inc. would like to thank you for selecting our products. We take great care in making certain that our products leave the factory in flawless condition. Our products are properly packaged to arrive in that same condition.

SPECIAL NOTES

 **WARNING** /  **CAUTION** These terms refer to actions that may result in injury to your patient or staff member and/ or damage to your product. Damage caused by improper operation of your chair is not covered by your warranty.

 **WARNING:** Caregivers or others operating the product or moving the occupant must be aware of the location of the patient's hands and feet. Caregivers must confirm that the occupant's extremities are safely located before moving the chair from position to position, adjusting the position of the chair or moving the patient from the chair.

 **WARNING:** Place chair in a fully upright position or a fully reclined position when cleaning or maintaining your chair. Your recliner has moving parts that create pinch points. This chair moves easily without a patient in the chair and may create pinch points when not in these positions.

 **WARNING:** This recliner is designed to meet the needs of a wide range of patients. Some patients, due to their unique medical condition, may need assistance as they sit down or rise from a seated position. It is the responsibility of the care provider to assess these needs and provide assistance to frail, weak, or otherwise unsteady patients. Failure to follow these instructions can result in patient falls with potentially serious injury resulting.

 **CAUTION:** Models 59 and 89 are NOT designed to transport patients.

NOTE: The information contained in this document is subject to change without notice.

CHAIR CAPACITY INFORMATION

STANDARD RECLINERS:

54 series	300 lbs.
59 series	300 lbs.
65 series (Ascent)	300 lbs.
67 series (Ascent II)	300 lbs.
85 series	300 lbs.
87 series	300 lbs.
89 series	300 lbs.

XL RECLINERS:

56 series:	500 lbs.
58 series	500 lbs.
66 series (Ascent XL)	500 lbs.
68 series (Ascent II XL)	500 lbs.
86 series	500 lbs.
88 series	500 lbs.

RECEIVING NEW CHAIRS



CAUTION: New chair inspection must be done by someone who understands the instruction pages. Improper operation of the chair may damage the chair and void your warranty.

Note: For chairs with heat or heat and massage please refer to Appendix B.

New chair inspection

1. Remove all packing material including foam wrap and poly bag. If desired, the bag may be replaced after examination.
2. Examine chair surfaces for damage.
3. Operate all chair functions and options. This may include tables, casters and chair positions. Do this immediately upon receipt of your chairs.

To report damage

1. If the freight carrier is still at your location (it is your right to hold the freight carrier while you thoroughly inspect your delivery), note any damage on the bill of lading. Take pictures if possible. Be sure to keep shipping cartons, pallets and other shipping materials to prove damage to the freight carrier. It is also important to save an undamaged carton and pallet in case the chair must be returned to the factory.
2. Call Champion's customer service immediately to report the damage: 800-998-5018.
3. All claims must be filed by the consignee and reported to Champion Manufacturing, Inc. within 5 days of receipt of the shipment.

Return authorization

1. Champion customer service must authorize all returns. Champion customer service will issue a return authorization number by fax or email. The customer does have the right to refuse any damaged chair from the carrier at the time of delivery.
2. All returns **must** be sent prepaid by the sender with the exception of provable shipping damage.

Storage

1. Cover chair and store in a dry area.
2. DO NOT place objects on top of the chair that may damage the vinyl.

IN-SERVICE PROCEDURES

Before chairs are put into service, all personnel should review this manual.

In the belief that an actual demonstration of the product is more effective than written instructions, an on-site in-service by a Champion representative may be available depending upon the delivery circumstances.

Pay special attention to the hang tag attached to the handle, or chair back. This identifies actions that may damage your product. It is extremely important that chairs are operated properly and used in the manner in which they were designed.

Certain improper methods of operating the chair can damage the chair and void the warranty. In the event that you do not receive your in-service packet, call customer service to obtain one: 800-998-5018.

 **WARNING: Place chair in a fully upright position or a fully reclined position when cleaning or maintaining your chair. Your chair has moving parts that create pinch points. This chair moves easily without a patient in the chair and may create pinch points when not in these positions.**

 **WARNING: Never place your hands near or on a recliner mechanism when it is in motion. Never clean or maintain a chair when an occupant is in the chair. The occupant is able to control the chair's position and may move the chair position unexpectedly, creating pinch points.**

 **WARNING: Keep hands, feet and legs clear of the recline mechanism.**

 **WARNING: When closing the leg rest by hand, make sure your hand is placed on the top upholstered surface of the footboard only not under the edges as this product has moving parts that may create pinch points. Keep all body parts clear of the recline mechanism, latches, leg rest and other moving parts**

 **CAUTION: DO NOT overload chair. Observe the specified maximum weight capacity for the chair model that you have selected.**

 **CAUTION: DO NOT attempt to force the chair into position; permanent damage may result. The chair works with normal effort when operated properly**

OPERATING INSTRUCTIONS

For safe recliner operation:

1. **Always** set the caster brakes before allowing your patient to get in or out of the chair. Release the caster brakes **only** when the chair is being relocated; and reset the caster brakes upon arriving at your destination. Never assume that the caster brakes have been set; check to ensure that the caster brakes are engaged before helping anyone in or out of the recliner.
TIP: Always rotate casters to the front of the chair for ease of locking and monitoring status, do this on arrival at your destination by pushing (or pulling) the chair to the front and then pulling (or pushing) the chair to the back to rotate the casters to the front.



WARNING: DO NOT enter or exit the chair with the leg rest extended.

2. Place the chair in the upright position before allowing the patient in or out of the chair. **Do NOT** enter or exit the chair with the leg rest extended. For shorter patients the foot tray may be used as an assist to allow easier entry to the chair. Patients over 225 pounds should not use the foot tray as a step. Please note and follow the capacity limits of the recliner being used.
3. Caster brakes should be locked before using the removable arm top or swing-away arm option.
4. The removable arm top should be replaced and securely latched as soon as a patient transfer has been made.
5. Swing-away arm should be closed and the arm securely latched as soon as the transfer or maintenance operation is complete. An occupant should never be transported with the arm top removed or the swing-away arm opened. Chairs with removable or swing away arms should never be left unattended when an arm is not secured. Check that the arm is latched by pulling outward on the arm.



CAUTION: Caregiver should NEVER attempt to raise the front wheels off the floor by pushing on the rear handle with a patient in the chair. This could damage the chair mechanism.

6. When transporting a patient, pull the foot tray out to the extended position, and be sure that the chair is in the upright position. Any recliner not equipped with a foot tray is not considered an appropriate transport chair. Never move recliner while patient is in seat with their feet dangling.

This recliner is designed with a “**zero-wall” type mechanism**. (All mechanisms require some space between the chair back and the wall for proper operation.) The chair seat and back move forward with you when you recline. Remember that the chair occupant will move in the same manner as they recline in the chair. The mechanism maintains the patient’s weight over the center of the chair, **and operates best with the patient seated all the way to the back of the chair.**

Champion Recliner Operation



1
LOCK CASTERS



2
EXTEND PULL-OUT STEP



3
ENTER AND SIT BACK



4
UPRIGHT POSITION



5
RELEASE HAND LEVER FOR "TV" POSITION. Foot rest will rise.



6
"TV" POSITION



7
PUSH BACK WITH HEAD AND SHOULDERS. To assist, grasp recliner arms and pull hips forward.



8
FULL RECLINE



9
SIT UP TO RETURN TO "TV" POSITION. To assist, grasp recliner arms and push hips back.



10
RETURN TO UPRIGHT POSITION. Foot rest will "click" when latched.



11
UPRIGHT POSITION FOR EXITING CHAIR



12
EXITING THE CHAIR

Exiting with Attendant Assistance



1
Locate and move hands and feet to safe location.



2
Move to the rear of the chair and use push handle to lift back to "TV" position.



3
Move to front of the chair and push the foot rest closed.



4
Allow exit once foot rest is latched.



NEVER exit without closing foot rest.



NEVER exit while reclined or if foot rest is extended.



NEVER exit from the side of the chair.



NEVER put your hands into the mechanism area.

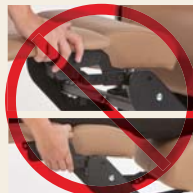

NEVER put your hands into the mechanism area.



NEVER force the foot rest closed.

OPERATING INSTRUCTIONS

Chair positions (Upright, TV and Full Recline)

 **WARNING: NEVER place your hands near or on a recliner mechanism when it is in motion. DO NOT put your hands where you cannot see.**

 **WARNING: A caregiver can control the motion of a leg rest as the chair moves from upright to "TV". To do so, place your palm against the upholstered top of the leg rest, well away from scissors of the mechanism below the short sides of the footrest. Release the leg rest with your opposite hand and use your palm to control the motion.**

To move from upright to the "TV" position:

1. With the chair in the upright position, set or confirm that the caster brakes are set.
2. Occupant should sit down and fully back in the chair with calves touching the leg rest.
3. Pull the mechanism release lever located on the lower arm panel.
4. Raise your feet and legs to recline to the "TV" position.

Note: To assist an occupant in raising their leg rest, grasp the leg rest near the center on a "long" side, well away from the recliner mechanism.

Note: It is not possible to recline the chair unless the recline release lever has been activated. It is not necessary to operate the recline release to close the leg rest.

To move from "TV" position to full recline position:

1. From "TV" position, push back with your head and shoulders to move your body forward, moving easily to a full recline position.
2. Should the occupant be in a weakened condition and need help to recline; downward pressure may be applied to the push handle, located at the back of the chair; or directly to the back itself.

Note: Do not push on the chair arms to assist chair operation; if necessary, grasp the chair arms and pull to help move your body forward into the full recline position.

 **CAUTION: DO NOT attempt to close the chairs leg rest while in the full recline position. Doing so may damage the mechanism and void your warranty. Return the chair to the "TV" position before closing the leg rest.**

To return to the "TV" position:

1. Simply lean forward; raising head and shoulders up should return the chair to "TV" position.
2. If this does not return the chair to "TV" position, you may push on the chair arms to help move your body backwards into the "TV" position.

Note: DO NOT pull on the arms; this will move your body the wrong way.

OPERATING INSTRUCTIONS

 **WARNING: DO NOT put your hands where you cannot see. To assist a patient in closing the leg rest; place your palm against the upholstered top surface and press downward in the center well away from the recline mechanism at the sides.**

To return to a full upright position from "TV" position:

Apply pressure to the leg rest until the leg rest returns to the locked position and the back is in the upright position.

Trendelenburg Option

We recommend that health care professionals who will be using this chair become thoroughly acquainted with the recliner and the Trendelenburg option prior to its use with a patient.

 **CAUTION: Operation of the Trendelenburg option must be in the proper sequence to be effective. First move through the recline functions then actuate the trend option.**

 **CAUTION: The Trendelenburg release must be fully actuated and held for the chair to operate properly.**

 **CAUTION: Once the chair has been placed in full Trendelenburg position, it is possible to adjust the Trendelenburg position upward **ONLY** after returning the chair from Trendelenburg to "TV" position, and back through full recline; **STOPPING THE CHAIR AT THE DESIRED POSITION WHILE ON THE WAY DOWN.****

To actuate the Trendelenburg option:

1. Follow the operating instructions to place the chair in a full recline position.
2. Locate the Trendelenburg actuator release lever on the chair back.
3. Grasp the push handle, "**pull and hold**" the Trendelenburg release lever. Lower the chair and occupant to the Trendelenburg position. Release the actuator to lock the chair back in position. Should you choose to place the chair in a position short of full Trendelenburg, stop the chair back at the desired position and release the actuator while in motion.

To return from Trendelenburg option:

1. "**Pull and hold**" the Trendelenburg actuator release lever as you lift the chair back to the "TV position". Release the actuator to lock the back in position.
2. The chair may now be actuated into any of the standard chair positions according to the operating instructions.

OPERATING INSTRUCTIONS



CAUTION: DO NOT overload chair. Observe the specified maximum weight limit for the recliner model that you have selected.



CAUTION: DO NOT attempt to force the chair into position; permanent damage may result. The chair works with normal effort when operated properly.



CAUTION: DO NOT attempt to close leg rest unless the chair is in "TV" position; (seat all the way in and back upright).



CAUTION: DO NOT use Trendelenburg lever to recline the chair. Always return chair to "TV position" after using Trendelenburg. Failure to do so may not allow back to be put into the Trendelenburg position when needed.



WARNING: Keep hands, feet and legs clear of the recline mechanism.

Actuation of the recline and Trendelenburg device by staff

In the event that a chair is not in full recline, and the chair occupant's condition makes them unable to assist the staff in movement of the chair from one position to another; we suggest the following:

1. To move the chair from full upright position to TV position, stand facing the side of the chair with the mechanism actuator, pull and hold the actuator while raising the foot rest to reach the "TV" position. To raise the foot rest grasp in the center on a long side well away from the recliner's scissor mechanism.
2. Turn and face the chair occupant, grasp the leg rest on the long side, at the edge toward the patient, near the middle well away from the recliner's scissor mechanism. Pull up and back to move the chair to full recline position **or simply place your hand on the back pillow and push downward to move to full recline position.**
3. Move to the back or turn to the side of the chair and actuate the Trendelenburg option according to the aforementioned directions. You may push on the back as you pull and hold the Trendelenburg actuator to move the chair rapidly to full Trendelenburg.

Setting the Trendelenburg Feature

The Trendelenburg function should be operated by the caregiver. Your chair must be purchased with the Trendelenburg option when it was ordered. If your chair has this option, follow these directions for operation.

1 ADJUST TO FULL RECLINE POSITION

Before operating the Trendelenburg function, you must move the chair to the full-recline position. Pull the side lever to release the foot rest. Then push the chair backrest as far as it will go into the full-recline position.



RELEASE FOOT REST WITH SIDE LEVER



TV POSITION



FULL RECLINE POSITION

2 PLACE THE RECLINER IN THE TRENDELENBURG POSITION

Locate the Trendelenburg lever on the chair back (shown to the right). Pull the lever all the way up and hold as you push the backrest down as far as it will go to the Trendelenburg position (shown to the right bottom). You may stop at any position going downward by releasing the lever.



LOCATE BACK LEVER



RAISE AND HOLD LEVER



PUSH RECLINER BACK DOWN

Please note: The caregiver is shown at the back of the chair in these instructions for clarity. You may also perform this function from the side of the chair.



FULL TRENDELENBURG POSITION

3 RETURN TO UPRIGHT POSITION

To return the chair to upright position, locate the Trendelenburg lever on the chair back. Pull the lever all the way up and hold as you lift the backrest and return it to the fully-upright/TV position (shown at bottom right). It is recommended that this step be done from the back of the chair.



LOCATE BACK LEVER



RAISE AND HOLD LEVER



LIFT RECLINER BACK UP

4 RAISE TO FULL UPRIGHT POSITION

Once the backrest is returned to the fully-upright/TV position, push the foot rest down until you hear it click and lock in place. To avoid damage to the mechanism, the foot rest should never be pushed down until the backrest is returned to the fully-upright/TV position.



RAISE BACK OF RECLINER



PRESS FOOT REST DOWN



FINAL UPRIGHT POSITION

CHAMPIONTM
Quality Healthcare Seating Products

OPERATING INSTRUCTIONS

Operation of the swing arms (if equipped)

 **WARNING:** Your recliner has moving parts that create pinch points. When the swing arms are open, those points are fully exposed. Patients should **NEVER** be left in a chair with the arms in the opened position. **THE CHAIR SHOULD NOT BE LEFT UNATTENDED, WITH THE ARMS UNLATCHED.**

 **CAUTION:** Be aware of the path the arm is taking. Swinging the arm into objects may result in vinyl damage. It is recommended that opening the arm be done with the chair in the fully upright position or the fully reclined position. If the arm on your chair is equipped with a fold-down table, relocate the items on the table top and fold the table top down.

Swing arms hinge at the back and may be opened a full 180 degrees. To do this, standing at the side of the chair, grasp the release handle and lift to release, and swing the arm open.

Once a patient transfer or maintenance is complete, the arm should be returned to the locked position. To do this, swing the arm back toward the front of the chair until you hear the “click” of the release handle being secured by the latch; **pull outward on the arm to ensure the arm is securely latched.** It may be necessary to lift slightly to move the arm into position for the handle to latch.

NOTE: The swing arms may be opened in the upright position to allow access to the thumb-knobs that secure the quick release seat to the mechanism. The balance of the operation of removing the quick release seat is as noted in this manual.

PROPER USE OF FOOT TRAY

The foot tray is a feature available on many Champion recliner models. The foot tray is useful as an assist for patients getting into or out of the recliner, re-positioning in the recliner, and as a foot support while sitting fully upright or being transported in the recliner.

⚠ WARNING: Never move chair while patient is in the seat in the upright position with their feet dangling.

⚠ WARNING: The foot tray can support up to 225 lbs., but may become “tippy” with weights over that.

The foot tray pulls out from under the recliner foot rest. Before use, make sure chair casters are locked and ensure that the foot tray is in the fully-extended position. To fully extend the foot tray, pull it out from the front of the recliner until you feel the front edge of the foot tray drop slightly. In this position, the foot tray cannot be pushed back under the chair to the “stowed” position unless you first lift on the front edge of the tray.

To stow the foot tray, lift up on the front edge of the tray and slide it back under the recliner as far as it will go.

Staff should always advise patients that the foot tray has been extended. Staff should never allow a patient to stand on the foot tray unattended. Patients over 225 lbs. should not use the foot tray as a step.

⚠ WARNING: Any recliner not equipped with a foot tray is not considered an appropriate transport chair.

CHAIR OPTIONS & ACCESSORIES

Options are chair features that must be installed at the factory when the chairs are produced.

Central Locking Caster Option

The central locking caster feature available only on swing arm chairs, enables the staff to lock all four casters with pressure from their foot. The red side locks the casters and the green side of the pedal unlocks them.

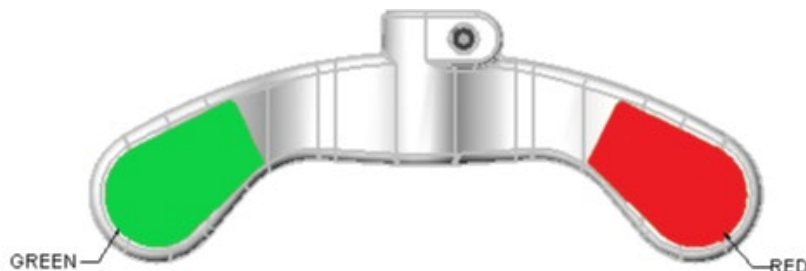

CHAIR OPTIONS & ACCESSORIES

Trendelenburg Option

The Trendelenburg feature creates multiple positions from full recline through flat to full Trendelenburg. Refer to the in-service DVD for operating instructions and applicable section of this manual. **Use this feature only when the chair is in full recline position.**

TV Bracket

Right-hand mounting bracket for use with your selected monitor/television system.

Accessories are features that may be ordered for your Champion chairs at any time. Some installation may be required. Accessories can be installed in the factory or in the field by the facility.

Fold-Away Side Tables

The fold-away side tables are mounted on the arms of the chair and can be ordered with cup holders.

Operate by:

1. Raising table and securing both support brackets.
2. Release brackets to return to stored position.



WARNING: DO NOT use table as a seat.



CAUTION: Remove items and fold tables down prior to moving the chair or the swing arm.

Cushion Wedge

This removable support provides additional surface for arm support as well as closing the gap between inside of chair arms for smaller patients.



CAUTION: Do not place comfort items between patient and heat source in chair if chair is equipped with heat. The comfort item may trap heat and when the item is removed the patient may experience elevated temperatures.

Head Pillow/Lumbar Support

This removable cushion can be used for head or lumbar support. The pillow attaches around back of chair with hook and loop fastener strap to allow placement of pillow at various positions to best suit the patient.

IV Pole

Stainless construction, 1" diameter IV pole features two or four rams horn hooks, adjustable with infinite positions; extended effective length 64".

IV Pole Bracket

This bracket is used to mount IV pole on backside of either or both arms and accommodates a 1" diameter pole.

IV Pole Base

The IV pole base accepts transfer of IV pole from chair bracket to IV pole base allowing patient to be mobile and free of the chair.

NOTE: Not all chair functions, options and/or accessories are covered in this manual.

USE OF IV POLE	1	HOOK
	2	RELEASE BUTTON
	3	TOP SECTION OF TUBE
	4	BOTTOM SECTION OF TUBE
	5	IV POLE BASE UNIT

THIS INSTRUCTION SHOWS
HOW TO USE THE IV POLE INFINITE POSITION FEATURE.
HOW TO USE WITH BASE UNIT.

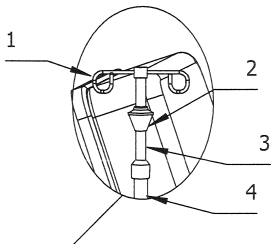
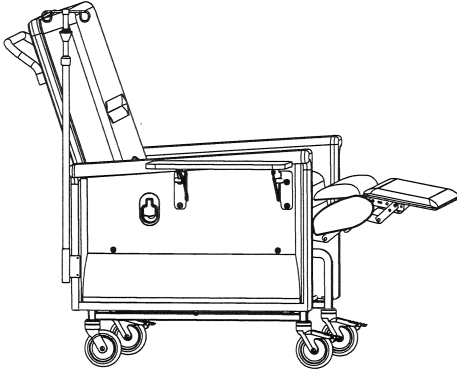



TO RAISE: LIFT TOP SECTION TO DESIRED HEIGHT

TO LOWER:
GRASP TOP SECTION OF TUBE AS YOU
PUSH UP SLIGHTLY ON RELEASE.
LOWER TOP SECTION OF TUBE.
LOWER TO DESIRED HEIGHT.

TO INSERT:
PLACE IV POLE OVER CENTER,
PUSH INTO POSITION IN OPENING
AND TURN TO LOCK

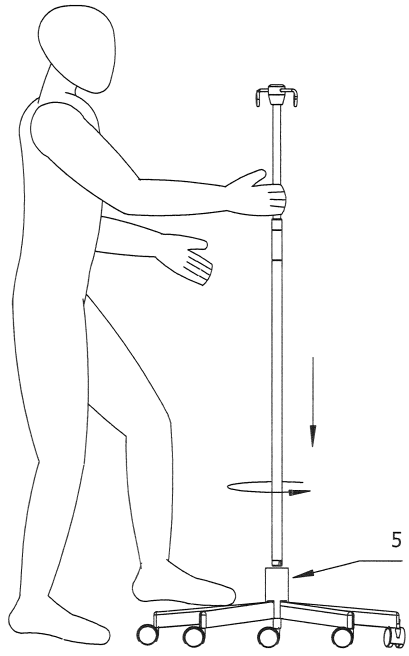
TO REMOVE:
HOLD BASE IN POSITION WITH FOOT
TWIST TO UNLOCK
LIFT IV POLE TO REMOVE



Note: Some components may have a different appearance than shown in the picture due to multiple models of chairs. The serial number of the chair informs Customer Service of the proper components for that chair.

GENERAL MAINTENANCE AND CARE OF CHAIRS

 **WARNING:** Place chair in a fully upright and securely latched position or a fully reclined position when cleaning or maintaining your chair. Your recliner has moving parts that create pinch points.

 **WARNING:** Never clean or maintain your chair with an occupant in the chair.

 **WARNING:** Before cleaning or disinfecting, always unplug the chair from the wall outlet.

 **CAUTION:** Never lubricate the Trendelenburg mechanism; doing so may cause the Trendelenburg mechanism to fail. Note: this mechanism is particularly prone to damage due to power washing.

 **CAUTION:** Avoid liquid ingress into all electronic components.

 **CAUTION:** Never clean the chair in a wash tunnel, with a high-pressure cleaner, or spray liquids on the electronics. Do not pressure wash chair or electronic components.

Regular and careful cleaning of the upholstery with water and a mild soap can prevent hardening and embrittlement of the upholstered parts from such problems as body perspiration, skin oils, hair spray, hand creams and similar things that may affect the upholstery. It is not necessary or recommended that moving parts of the chairs be lubricated. Keeping the chair clean is the main maintenance requirement. Each facility should check their chairs and set their own maintenance schedule.

It is recommended that the underside of the chairs be checked periodically for waste materials that have fallen under the chair. For this purpose, use the quick-release seat feature to help gain access for removal of the waste. It is also recommended that the thumb screws on the quick-release seat be periodically checked to make sure they are tight.

Check that the hinge fasteners, latch mount and release mount fasteners are secure on the swing arm chairs. The top of each latch mount has plastic buttons that are designed wear points. Check the buttons and replace when worn to prevent damage to vinyl covers. These checks should be done monthly, and then tailor to your findings. (See applicable schematics and parts listing to identify these components).

If a part becomes worn or broken, see the sections regarding service and warranty for information, please reference service and warranty section of this manual.

USE OF QUICK RELEASE SEAT FEATURE

WARNING: THIS CHAIR HAS MOVING PARTS THAT MAY CREATE PINCH POINTS. WORK OR CLEANING SHOULD BE PERFORMED ONLY IN THE UPRIGHT POSITION WITH THE CHAIR LATCHED OR IN THE FULL RECLINE POSITION. KEEP YOUR HANDS CLEAR OF THE MECHANISM WHEN MOVING THE CHAIR FROM ONE POSITION TO ANOTHER.

A	BACK PILLOW
B	SEAT
C	CENTER BOARD
D	FOOT REST
E	LEG REST MECHANISM SIDE COVER
F	FOOT TRAY
G	UPHOLSTERED ARM
H	RECLINE MECHANISM ACTUATOR
I	THUMB KNOB

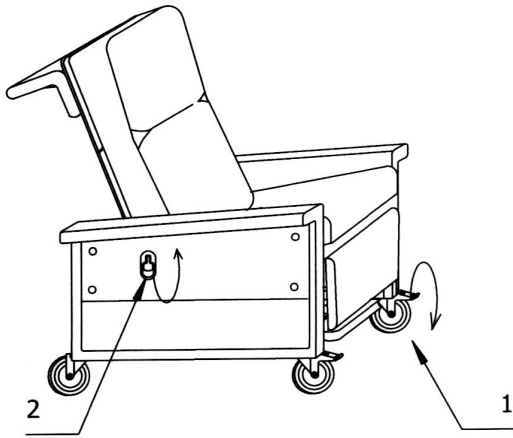

1. LOCK FRONT CASTERS
2. OPERATE RECLINE MECHANISM ACTUATOR

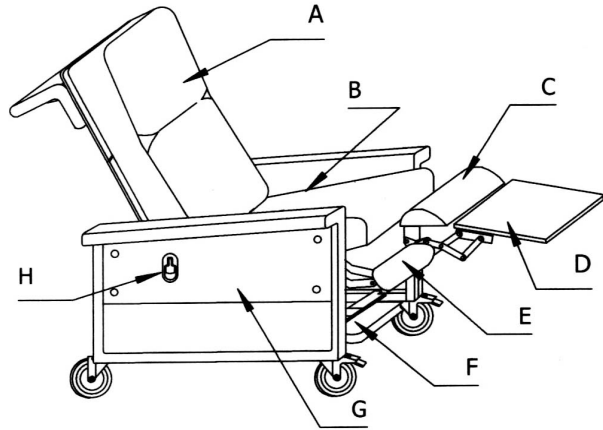

3. CHAIR SHOWN IN "TV" POSITION, CASTERS LOCKED.

THIS ILLUSTRATION SHOWS HOW TO PLACE A RECLINER-TRANSPORTER IN "TV" POSITION.
ALSO USE THE ILLUSTRATION TO IDENTIFY BASIC CHAIR PARTS

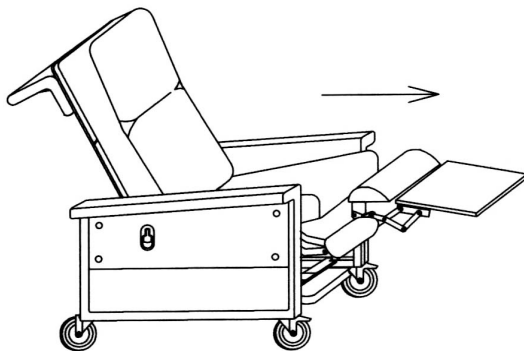

4. WITH CHAIR IN "TV" POSITON, PULL LEG REST FORWARD TO GO TO THE FULL RECLINE POSITION TO EXPOSE THE THUMB KNOBS THAT SECURE THE SEAT.

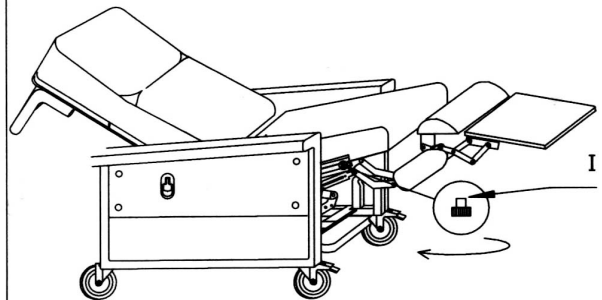

5. LOCATE AND REMOVE THE THUMB KNOBS THAT SECURE THE SEAT. DO NOT REMOVE THE SEAT.

THIS ILLUSTRATION SHOWS THE LOCATION AND HOW TO REMOVE THE SEAT FASTENERS.

Note: Some components may have a different appearance than shown in the picture due to multiple models of chairs. The serial number of the chair informs Customer Service of the proper components for that chair.

USE OF QUICK RELEASE SEAT FEATURE

J CLIP

K FLANGE

WARNING: THIS CHAIR HAS MOVING PARTS THAT MAY CREATE PINCH POINTS. WORK OR CLEANING SHOULD BE PERFORMED ONLY IN THE UPRIGHT POSITION WITH THE CHAIR LATCHED OR IN THE FULL RECLINE POSITION. KEEP YOUR HANDS CLEAR OF THE MECHANISM WHEN MOVING THE CHAIR FROM ONE POSITION TO ANOTHER.

WARNING: FAILURE TO INSTALL THUMB KNOBS WILL CAUSE YOUR SEAT TO BE LOOSE.

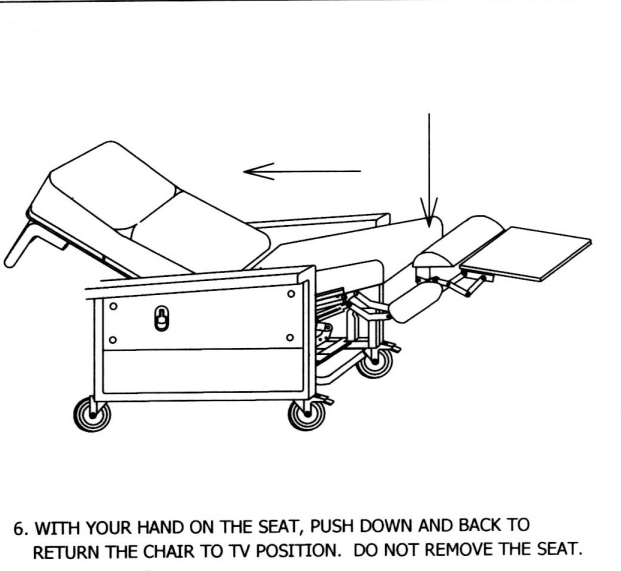

6. WITH YOUR HAND ON THE SEAT, PUSH DOWN AND BACK TO RETURN THE CHAIR TO TV POSITION. DO NOT REMOVE THE SEAT.

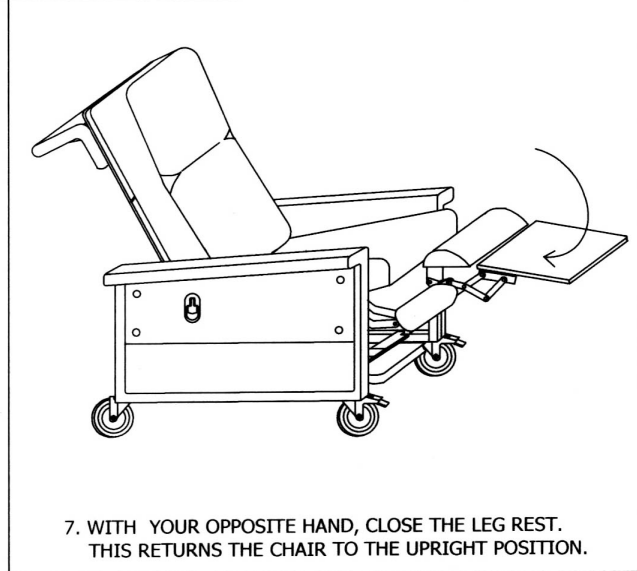

7. WITH YOUR OPPOSITE HAND, CLOSE THE LEG REST. THIS RETURNS THE CHAIR TO THE UPRIGHT POSITION.

THIS ILLUSTRATION SHOWS HOW TO RETURN A RECLINER-TRANSPORTER IN UPRIGHT POSITION.

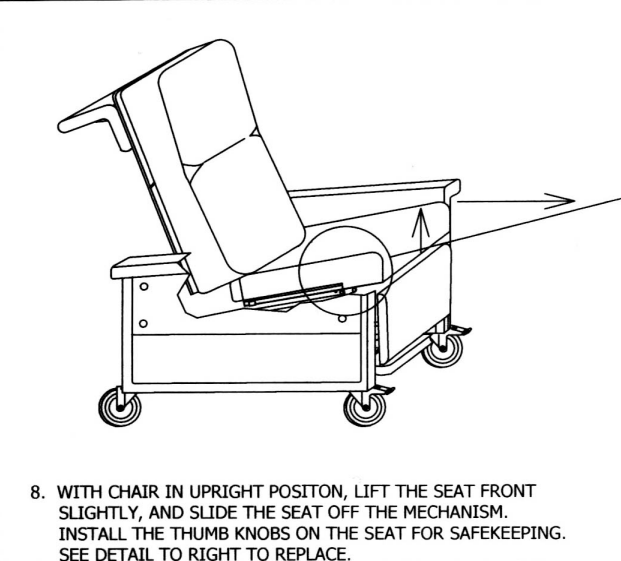

8. WITH CHAIR IN UPRIGHT POSITION, LIFT THE SEAT FRONT SLIGHTLY, AND SLIDE THE SEAT OFF THE MECHANISM. INSTALL THE THUMB KNOBS ON THE SEAT FOR SAFEKEEPING. SEE DETAIL TO RIGHT TO REPLACE.

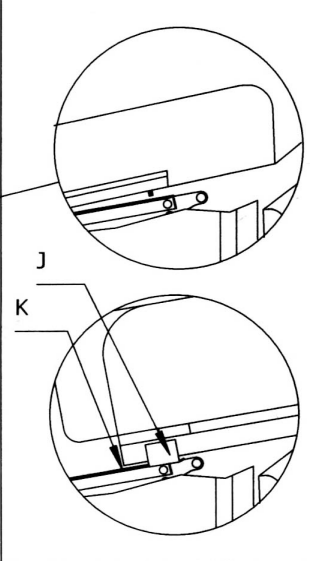

LIFT THE FRONT OF THE SEAT UNTIL BOLT CLEARS THE MECHANISM. SLIDE THE SEAT OFF.

TO REPLACE THE SEAT, REMOVE THE THUMB KNOBS. SET THE SEAT ON THE MECHANISM WITH THE CLIP ON EACH SIDE OF THE SEAT UNDER THE FLANGE ON THE MECHANISM. SLIDE THE SEAT BACK. LIFT THE SEAT AND PUT THE BOLT THRU THE SLOT IN THE FLANGE.

REPEAT STEPS 2 - 5 TO SECURE THE SEAT WITH BOTH THUMB KNOBS.

THIS ILLUSTRATION SHOWS HOW TO REMOVE AND REPLACE THE SEAT.

Note: Some components may have a different appearance than shown in the picture due to multiple models of chairs. The serial number of the chair informs Customer Service of the proper components for that chair.

GENERAL SAFETY FOR CHAIRS WITH POWERED OPTIONS

(Heat, Heat/Massage)

Please advise your cleaning staff to keep in mind these safety instructions.

 **WARNING:** To reduce the risk of electric shock, always unplug this product from the wall outlet before cleaning, disinfecting, or replacing any parts.

 **WARNING:** Never operate the chair if it has a damaged cord or plug, if it is not working properly, if it has been damaged, or is not dry.

 **WARNING:** Keep chair and electronics dry – do not operate in a wet or moist condition or environment

 **WARNING:** Do not power wash chair or electronics or swab down electronics with a wet mop.

 **CAUTION:** As you Unplug chair from the wall outlet examine your cord and plug for wear or damage including, but not limited to wear, cuts breaks, or bent prongs.

 **CAUTION:** Do not pull the chair by the power cord.

 **CAUTION:** Do not roll chair or other equipment over the power cord or the cord to the handset.

 **CAUTION:** Do not modify the plug or use an extension cord or adapter to plug into the wall outlet.

 **CAUTION:** Do not use outdoors.

GENERAL CLEANING PRECAUTIONS

 **WARNING:** NEVER mix ammonia, or a cleaner with ammonia, with bleach as dangerous compounds may result.

 **WARNING:** When solvent type cleaners are being used, care should be exercised. KEEP AWAY from fire or flame and use in a well-ventilated area.

 **CAUTION:** Treat all stains immediately to prevent it becoming a permanent stain.

 **CAUTION:** Several light applications of a cleaning agent are less harmful than a single concentrated application to remove a stain.

 **CAUTION:** Some fabric dyes, including indigo dyes commonly used in denim jeans, may migrate to the surface of the material and have the ability to create a permanent stain. This is increased by humidity and temperature and may be irreversible. To reduce the likelihood of a problem from this or any stain, clean as soon as noticed.

 **CAUTION:** Indiscriminate use of strong solvents can damage or discolor vinyl.

 **CAUTION:** Do not use abrasive household cleansers or steel wool.

 **CAUTION:** Residue left by cleaning agents will degrade and shorten the life and/or affect the product's appearance if not removed.

 **CAUTION:** Do not use steam cleaning or hot water to clean.

 **CAUTION:** Do not use an iodine-based solution or the upholstery will become stained.

GENERAL CLEANING - UPHOLSTERY

REGULAR CLEANING: Remove excess soil with a damp non-abrasive cloth. Use a soft white cloth and solution of mild liquid soap or water based cleaner and water. Rinse all cleaning agents thoroughly with water and dry with a soft cloth.

IMPORTANT: For specific cleaning instructions, please see manufacturer's cleaning instructions.



CAUTION: Do not use cleaners marked "for hard non-porous surfaces only" unless approved by the upholstery manufacturer. Such use may cause surface deterioration.



CAUTION: Pretest any cleaning method or agent in a small hidden inconspicuous area.

STAIN REMOVAL: For best results treat all stains immediately. Remove any fluids by blotting with a clean, colorfast, absorbent cloth. Flush stain with water and dry with clean cloth. Remove as much of the solid or semi-solid substances as possible using a flat object. After removal, vacuum thoroughly using the proper attachments before cleaning with an agent. Clean stains or spots from the edge of the stain working towards the center.

GENERAL CLEANING – PLASTIC TABLE TOPS



CAUTION: Do not use strong solvents such as Picrin® or Goof-Off®. They will damage your table top.



CAUTION: Compounds that are safe to use on the vinyl surfaces of your chair may not be appropriate for cleaning your table top.

It is always easier to clean the table immediately after a spill. When the residue from a spill has dried on the table, a soft bristle brush may be used to help bring it back into solution. Rinse the surface with clean water. For residue that is not readily soluble in bleach and water, try hot water and dish washing liquid. Rinse and use absorbent material to remove as much liquid as possible. You may also try rubbing alcohol, applying a small amount of alcohol with a cloth, rubbing the dried-on residue. It may take several applications to dissolve the residue.

GENERAL INFECTION CONTROL

INFECTION CONTROL: A solution of up to 10% bleach and water may be used. After using bleach solution be sure to rinse area with a soft cloth moistened with clear water and let dry. Bleach solutions not completely removed can fade the material. Never use bleach in full strength to clean these materials. Information in regard to the strength of bleach solution from the vinyl manufacturer is meant to establish an upper limit beyond which damage might occur.

WARRANTY PROCEDURE

File a Warranty Claim

Calling customer service may institute a warranty claim. At that time, you will be asked to provide:

- your name and facility name
- your phone, fax number, email address
- **the serial number of your product**, and
- the nature of your problem

Having the above information available at the time that you call will speed the process. In order to provide prompt accurate service, it may be necessary to request further information about the chair function to accurately define the problem.

Warranty Coverage

Your coverage is per the Champion warranty. A copy of the current warranty was provided with this manual for your convenience. Please read this document.

Warranty Does Not Apply If:

- Repairs have been made that were not authorized or under the direction of Champion Manufacturing Inc's service department.
- Required repairs are due to normal wear and tear.
- Product has been abused, improperly used or maintained.
- Alterations have been made to the chair.
- Improper cleaning agents or methods have been used.
- Repairs have been made with parts other than Genuine Champion repair parts.

Whether your claim is covered under warranty may not always be determined at the time of your call. Where the possibility of improper use exists, a determination will be made upon receipt of damaged components or product. In these cases, components or product will be shipped with the express understanding that if damage is not covered by warranty **all costs are the responsibility of your facility.**

Service Parts will not be sold if your chairs are outside of the product lifetime of eight (8) years unless

- Chairs have been inspected and replacement parts verified as installed properly by an approved Champion technician for an extended life certificate.

Note: Shipping charges are not covered under warranty with the exception of provable shipping damage.

SERVICE INFORMATION

The mission of the Service Department is to get your chair up and running as quickly as possible. It is critical that the Service Department know what product you have, and exactly what is wrong with the product.

The most timely and cost-effective way for your chair to be repaired is for the Service Department to work with your maintenance department or equipment technician.

Determining the Problem

What is wrong with the chair should be determined by troubleshooting. The Service Department will assist you with this by asking you questions about the chair function.

Serial Number

The chair serial number identifies the precise configuration of your chair; this is critical to receiving correct components and instructions. **This number is required to process your request.**

The serial number is located in the back of the chair on the lower left side on the label entitled Champion Manufacturing -Serial #xxxxxx.

No parts will be shipped without a Serial Number to which they will be installed.

PARTS IDENTIFICATION

To identify worn or damaged components please refer to appropriate product schematics.

To obtain repair part numbers refer to the parts listing key using the schematics page and item number.

Parts orders may be placed by using the convenient fax order form in this manual or by calling Customer Service.

When placing an order by phone you will be asked to provide:

- your name and facility name
- your phone, fax number, email address
- the serial number of your product, and
- the nature of your problem

Having the above information available at the time you call will expedite the process. In order to provide prompt, accurate service it may be necessary to request further information about the chair function to accurately define the problem.

MEDICAL RECLINER-TRANSPORTER

SCHEMATICS
Schematics for Fix arm chairs only
Rev REL effective 06/15/19
ARM ASSEMBLY
TABLE ASSEMBLY
FRAME BASE

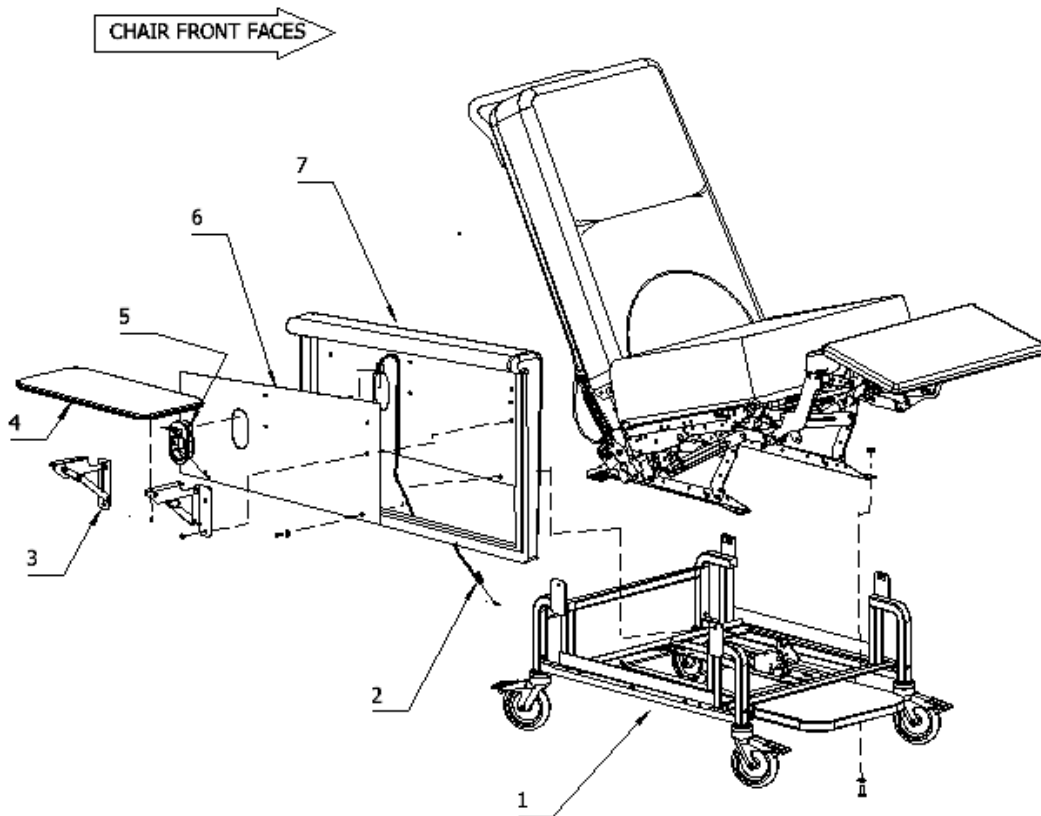

Note: Some components may have a different appearance than shown in the picture due to multiple models of chairs. The serial number of the chair informs Customer Service of the proper components for that chair.

MEDICAL RECLINER-TRANSPORTER

SCHEMATICS

Swing arm recliners

Schematic Rev REL effective 07/17/19

ARM ASSEMBLY

TABLE ASSEMBLY

FRAME BASE

FOR DESCRIPTION,
SEE PARTS LISTING ON
FOLLOWING PAGES.

CHAIR FRONT FACES

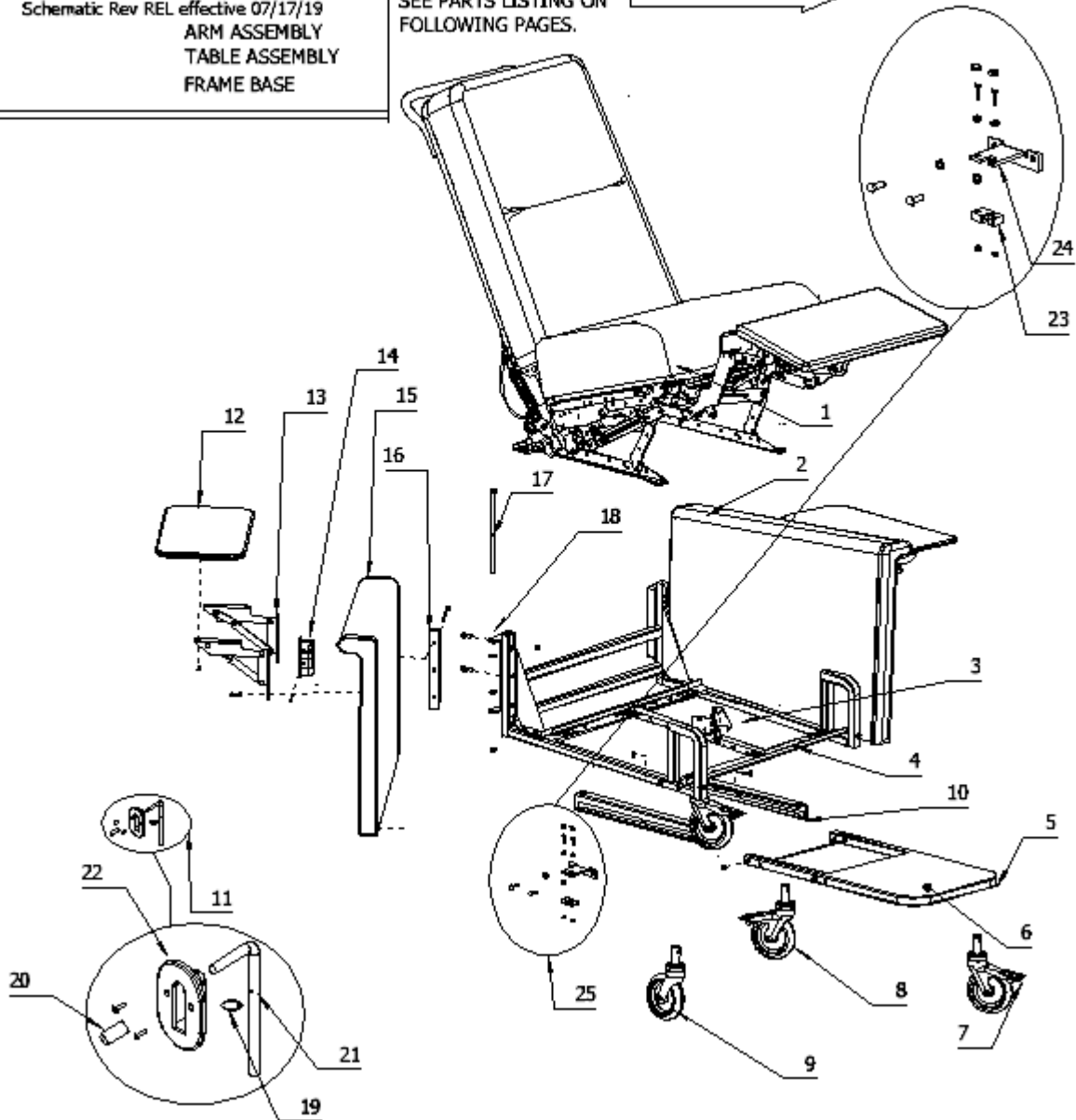

Note: Some components may have a different appearance than shown in the picture due to multiple models of chairs. The serial number of the chair informs Customer Service of the proper components for that chair.

MEDICAL RECLINER-TRANSPORTER

SCHEMATICS
UPHOLSTERY ASSEMBLY

BACK FRAME ASSEMBLY

Classic, Ascent & Alo Recliners
Schematic Rev REL effective 07/17/19

FOR DESCRIPTION,
SEE PARTS LISTING ON FOLLOWING PAGES

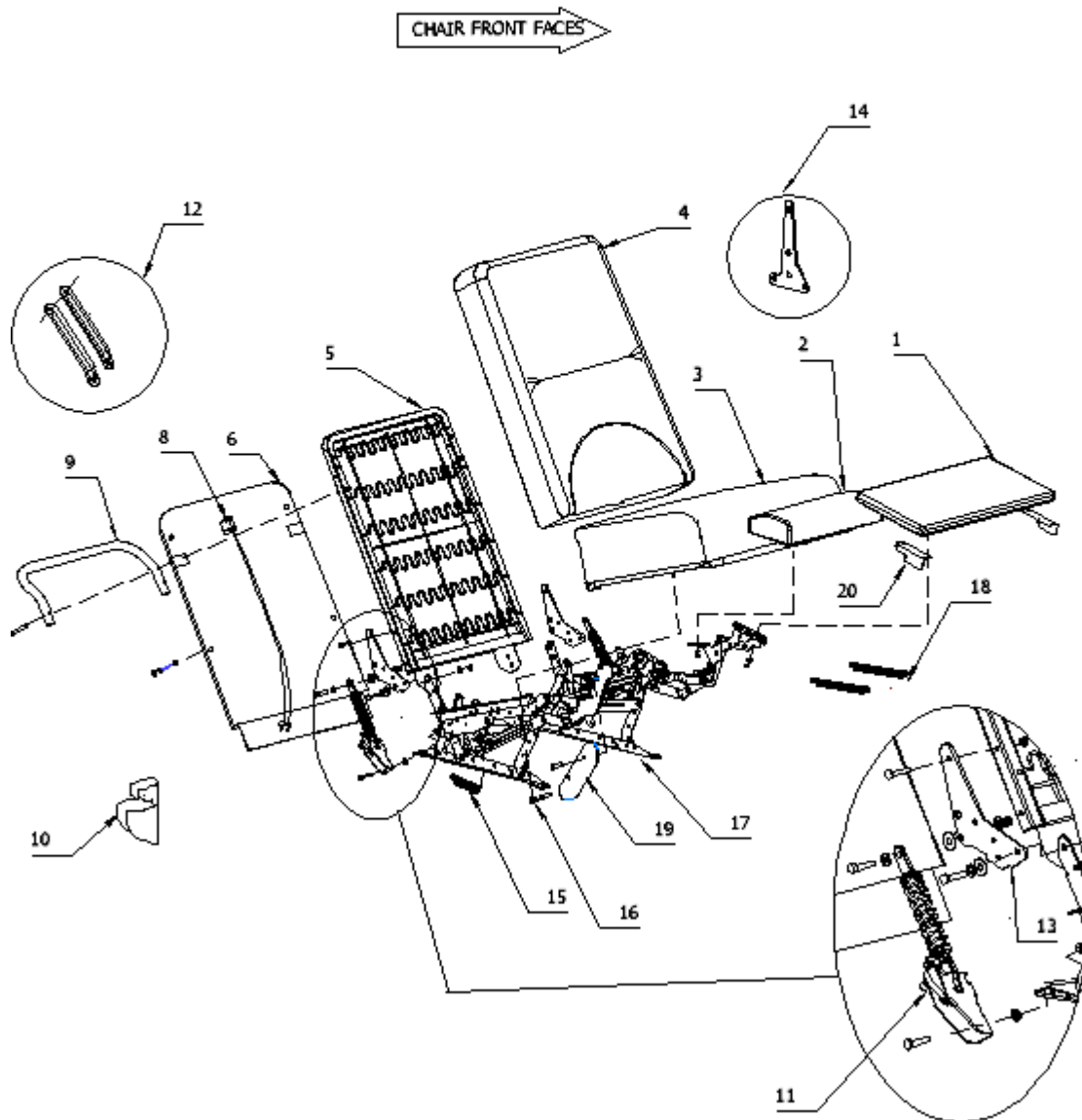

Note: Some components may have a different appearance than shown in the picture due to multiple models of chairs. The serial number of the chair informs Customer Service of the proper components for that chair.

MEDICAL RECLINER-TRANSPORTER

SCHEMATICS

FRAME BASE

FOOT TRAY

CASTERS

Exploded Base Rev REL 06/15/19

CHAIR FRONT FACES

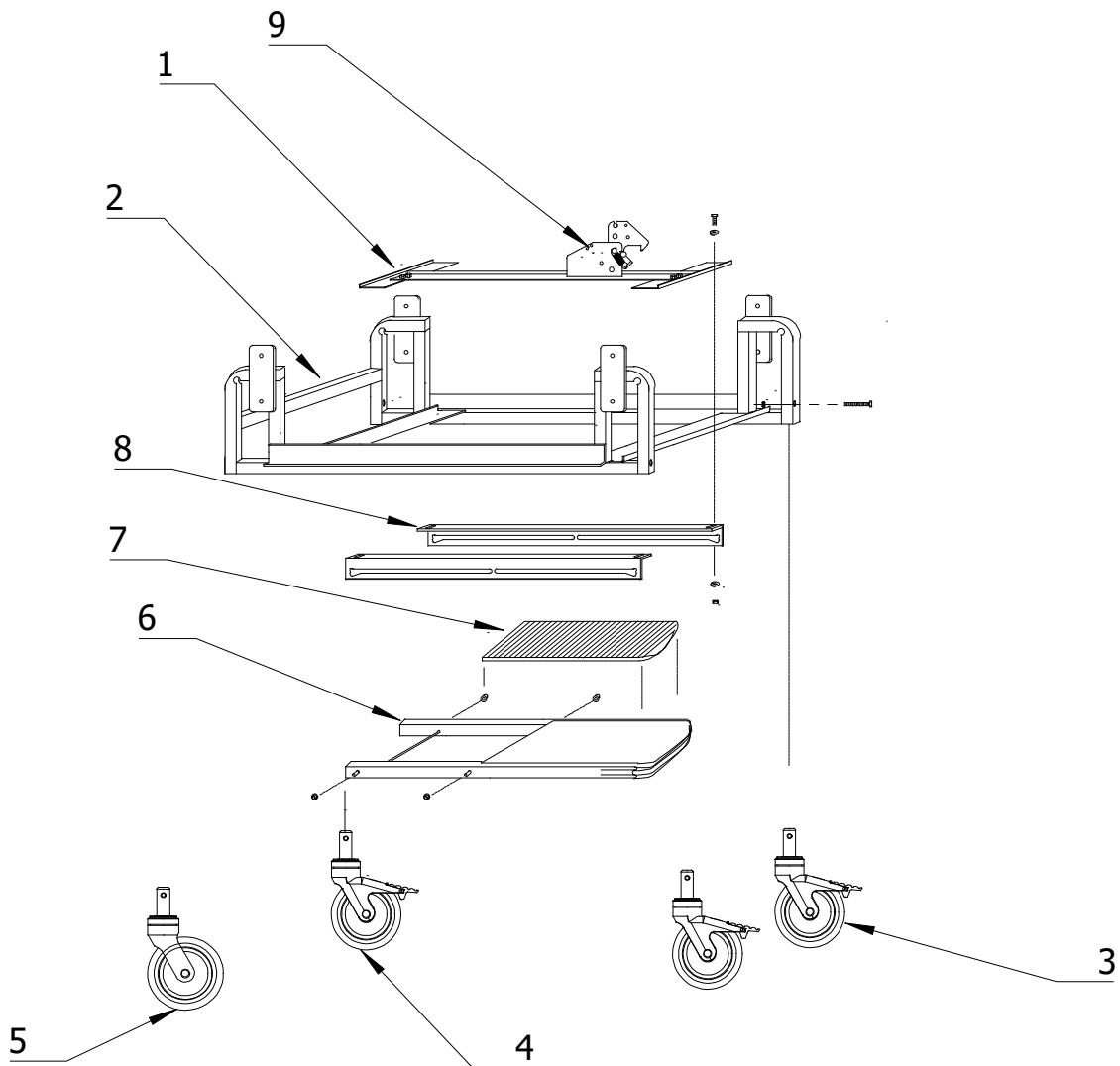

Note: Some components may have a different appearance than shown in the picture due to multiple models of chairs. The serial number of the chair informs Customer Service of the proper components for that chair.

MEDICAL RECLINER- TRANSPORTER			
PAGE-PART NUMBER	DESCRIPTION	PAGE-PART NUMBER	DESCRIPTION
26-01	COMPLETE FRAME BASE ASSEMBLY	28-01	FOOT REST UPHOLSTERED
26-02	RECLINE MECHANISMS ACTUATOR CABLE ASSEMBLY	28-02	CENTER BOARD ASSEMBLY
26-03	TABLE BRACKET SET	28-03	SEAT ASSEMBLY
26-04	TABLE TOP	28-04	BACK PILLOW ASSEMBLY
26-05	RECLINE MECHANISM ACTUATOR HANDLE ONLY	28-05	BACK FRAME (SHOWN WITH TREND)
26-6	UPHOLSTERED ARM INSERT (RIGHT WITH ACTUATOR SHOWN)	28-06	UPHOLSTERED BACK PANEL WITH TREND
26-07	ARM ASSEMBLY – FULL (WITH RIGHT ACTUATOR SHOWN)	28-07	BACK PAENT WITHOUT TREND (NOT SHOWN)
		28-08	TREND CONTROL
27-01	MECHANISM WITH ALL UPHOLSTERED PARTS ATTACHED- FOR ILLUSTRATION	28-09	PUSH HANDLE
27-02	LEFT HAND SWING ARM ASSBMELY	28-10	MECHLOK UPHOLSTERED COVERS
27-03	MECHANISM LATCH	28-11	MECHLK ASSEMBLY, RIGHT
27-04	SWING ARM FRAME BASE	28-12	LINK SET (WITH OUT TREND OPTION)
27-05	PULL OUT FOOT TRAY	28-13	BACK MOUNT BRACKET (TREND)
27-06	TREAD FOR PULL OUT FOOT TRAY	28-14	BACK MOUNT BRACKET (NO TREND)
27-07	CASTER - FRONT TOTAL LOCK	28-15	RELEASE SPRING
27-08	CASTER - STEERING	28-16	THUMB KNOB
27-09	CASTER - SWIVEL	28-17	RECLINE MECHANISM
27-10	TRACK SET FOR PULL OUT FOOT TRAY	28-18	MECHANISMS SPRING
27-11	RELEASE ASSEMBLY	28-19	MECHANISM SIDE COVER SET (1 SHOWN)
27-12	TABLE TOP	28-20	MECHANISM FRONT COVER SET (1 SHOWN)
27-13	TABLE BRACKET SET		
27-14	RECLINE ACTUATOR HANDLE ONLY	29-01	FLOOR RAIL ASSEMBLY
27-15	RIGHT HAND ARM ASSEMBLY	29-02	FRAME BASE
27-16	"C" HINGE ARM BRACKET	29-03	CASTER – TOTAL LOCK
27-17	3/8 X 16/9" HEX BOLT	29-04	CASTER – SWIVEL
27-18	"C" HINGE BASE BRACKET	29-05	CASTER – STEERING
27-19	RING COTTER	29-06	PULL OUT FOOT TRAY
27-20	CAP RELEASE HANDLE	29-07	TREAD
27-21	RELEASE HANDLE	29-08	TRACK SET FOR PULL OUT FOOT TRAY
27-22	RELEASE COVER	29-09	MECHANISM LATCH
27-23	LATCH		
27-24	LATCH ASSEMBLY MOUNT		
27-25	LATCH ASSEMBLY – RIGHT		
27-26	LATCH ASSEMBLY LEFT (NOT SHOWN)		

APPENDIX A

ACTUATION ADJUSTMENT:

TOOLS REQUIRED: 1/2" WRENCH, OPEN END/BOX END – 2

Please read all directions before making adjustment. Refer back to directions and illustrations as you make the adjustment. Call Customer Service if you have any questions or problems.



CAUTION: This adjustment requires tightening or loosening fasteners that effect the chair operation. If these components are tightened too much, the chair will be difficult to operate. If they are loosened too much, the chair may "drift" from one position to the next.



CAUTION: This chair has moving parts that may create pinch points. Work or cleaning should be performed only in the upright position with the chair latched or in the full recline position. Keep your hands clear of the mechanism when moving the chair from one position to another. Failure to install thumb knobs will cause your seat to be loose.

1. Assemble required tools.
2. Move the chair to access the back of the chair.
3. Sit in the chair and actuate it several times to become aware of the "ease of actuation". Move to the back of the chair. At the bottom of the back, locate the mechlok assemblies. If your chair is older, these may be behind a large fabric flap. If this is the case, separate the hook and loop fastener at the bottom of the flap to look behind it. Open or turn back the mechlok assembly covers. (See following illustration)
4. Locate the fastener at the top of the mechlok assembly. Use your wrenches to adjust the fastener assembly ¼ turn. (Loosen the fastener to make the chair recline more easily. Tighten the fastener to make the chair hold its position.) Locate the fastener at the bottom of the assembly and repeat the operation. Move to the opposite side of the back and repeat both operations.
5. Use the release at the side of the chair to move the chair to "TV position". Face the chair, grasp the seat bottom and pull down and back, placing the chair in the full recline position. Look between the bottom back pillow and seat for the back mount. Note that this is under a fabric cover; raise the cover to expose the fastener assembly. Adjust the fastener ¼" turn, replace the cover and repeat on the opposite side of the chair.
6. Standing at the chair front, push the seat back to return the chair to "TV position". With the chair in the "TV position", push down on the seat with one hand and use the other hand to push down on the leg rest to return the chair to the upright position. Sit in the chair and check the ease of actuation. Repeat the adjustment until the desired effect is achieved.

CHAMPION

PRODUCT: RECLINER, RECLINER-TRANSPORTER
 XXL RECLINER-TRANSPORTER
 SERVICE: ADJUST ACTUATION
 VIEW: RIGHT SIDE
 REV. B. DATE: 01/04/12 PC

DET	DESCRIPTION
A	MECHLOK ASSEMBLY
B	TOP OF MECHLOK ASSEMBLY
C	BOTTOM OF MECHLOK ASSEMBLY
D	FRONT OF BACK MOUNT
E	MECHLOK COVER
F	OPEN END BOX END WRENCH

WARNING: THIS CHAIR HAS MOVING PARTS THAT MAY CREATE PINCH POINTS. WORK OR CLEANING SHOULD BE DONE ONLY IN THE UPRIGHT POSITION WITH THE CHAIR LATCHED OR IN THE FULL RECLINE POSITION. KEEP YOUR HANDS CLEAR OF THE MECHANISM WHEN MOVING THE CHAIR FROM ONE POSITION TO ANOTHER.

NOTE: THIS ILLUSTRATION SHOWS THE CHAIR WITHOUT THE RIGHT ARM AND WITH PORTIONS OF THE BACK, MECHLOK COVER AND SEAT CUT AWAY. THIS IS TO MAKE THE ILLUSTRATION CLEARER; DO NOT REMOVE YOUR ARM TO MAKE THE ADJUSTMENT.

TOOLS: 1/2" OPEN END BOX END WRENCH -- 2
 DIRECTIONS:

1. TIGHTEN OR LOOSEN ALL FASTENERS BY 1/4 TURN. DO NOT LOOSEN FASTENER C MORE THAN 2 TIMES.
2. ACCESS FASTENERS B AND C FROM THE BACK OF THE CHAIR. TO ACCESS THE HEAD OF THE BOLT AT C, USE AN OPEN END /BOX END WRENCH WITH THE OFFSET TOWARD THE FASTENER. WORK FROM THE INSIDE OF THE CHAIR AT THE BACK. REACH OVER THE CENTER OF THE MECHLOK BRACKET WITH THE WRENCH TO ACCESS THE HEAD OF THE BOLT. (SEE BELOW.)

TO ACCESS D, PUT THE CHAIR IN FULL RECLINE AND RAISE THE COVER BETWEEN THE BOTTOM OF THE BACK PILLOW AND BACK END OF THE SEAT ASSEMBLY.

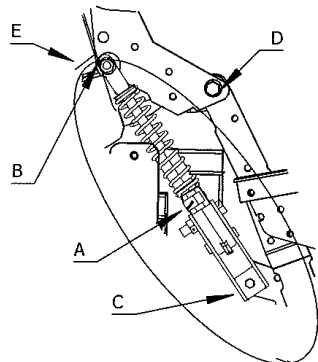

PRODUCT: RECLINER-TRANSPORTER
 OPTION: TREND

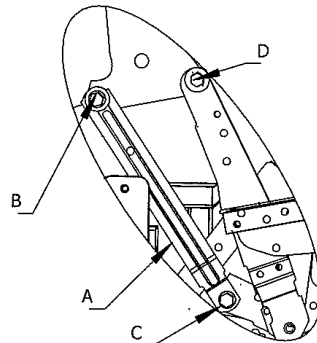

PRODUCT: RECLINER-TRANSPORTER
 OPTION: STANDARD

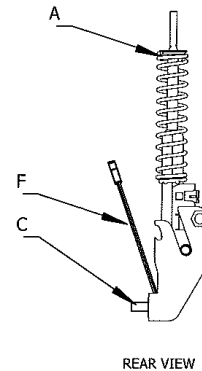

FIG. 1

Note: Some components may have a different appearance than shown in the picture due to multiple models of chairs. The serial number of the chair informs Customer Service of the proper components for that chair.

APPENDIX B – Heated and Heat/Massage Recliners

HEAT RECLINER GENERAL INFORMATION

 **WARNING:** Do not operate this product without reviewing the operating instructions along with any attachments that demonstrate proper operation of the basic functions of your chair.

 **WARNING:** The comfort item may trap heat and when the item is removed the occupant may experience elevated temperatures.

 **WARNING:** The operating range is 32-86°F, if the chairs have been recently delivered or stored in conditions outside this temperature range, the chairs should be allowed to come to ambient temperature prior to utilizing the heat function.

 **CAUTION:** No items should be placed behind the occupant's back or beneath them. Placing items (pillow, blanket, etc.) in the chair will expose the item to the heat generated by the system. Unlike the occupant's body, certain items may not absorb and dissipate the generated heat; this may expose the item to temperatures that are higher than noted here through trapped heat. This may cause damage to the chair, the item, and risk of contact with higher temperatures. Damage to the item or your chair is not covered by your warranty.

Double-Insulated Products

In a double-insulated product, two systems of insulation are provided instead of grounding. No grounding means is provided on a double-insulated product, nor is a means for grounding to be added to the product. Servicing a double-insulated product requires extreme care and knowledge of the system, and is to be done only by qualified service personnel. Replacement parts for a double-insulated product must be identical to the parts they replace. A double-insulated product is marked with the words "DOUBLE INSULATION" or "DOUBLE INSULATED". The symbol () is also able to be used to identify a double insulated product.

APPENDIX B (continued) – Heated and Heat/Massage Recliners

CHAIR SPECIFICATIONS

Please reference previous chair specification pages for all load and dimensional specifications of your heated chair. All chairs with heat are built to properly handle the specified load for that model chair. The heater option does **not** change the size or load capability of that model.

Power Requirements

Input: 100-240 VAC, 1.0 A max, 50-60 Hz

Output: 12 VDC, 3.5 A, 42 W

Average Measured Maximum Temperatures

LOW	98 °F
MEDIUM	102 °F
HIGH	105 °F

 **WARNING:** No items should be placed behind the occupant's back or beneath them. Placing items (pillow, blanket, etc.) in the chair will expose the item to the heat generated by the system. Unlike the occupant's body, certain items may not absorb and dissipate the generated heat; this may expose the item to temperatures that are higher than noted here through trapped heat. This may cause damage to the chair, the item, and risk of contact with higher temperatures. Damage to the item or your chair is not covered by your warranty.

RECEIVING NEW CHAIRS

NEW HEAT AND HEAT/MASSAGE CHAIR INSPECTION:

Reference earlier section on receiving new chairs, along with the following operational procedures.

 **WARNING:** The heat or heat/massage chair must be plugged into a properly grounded outlet and must not be modified in any way. If the three (3) blade plug does not fit your outlet, have one installed that meets your local codes by an electrician. Consult an electrician if you are unsure that the outlets are properly grounded. Do not use a three (3) blade plug to a two (2) blade adapter.

 **CAUTION:** Before plugging chair into wall outlet, it should be checked for condensation on the electrical components and dried if necessary. The chair should reach room temperature prior to plugging it in.

APPENDIX B (continued) – Heated and Heat/Massage Recliners

HEATER OPERATION

The Champion heated recliner continues to have the same occupant-controlled positioning with the added benefit of heated pads in the seat and back. The heat/massage recliner has massage motors built into the back cushion along with the heat system. This allows for additional occupant comfort at the push of a button.

⚠ WARNING: No items should be placed behind the occupant's back or beneath them. Placing items (pillow, blanket, etc.) in the chair will expose the item to the heat generated by the system. Unlike the occupant's body, certain items may not absorb and dissipate the generated heat; this may expose the item to temperatures that are higher than noted here through trapped heat. This may cause damage to the chair, the item, and risk of contact with higher temperatures. Damage to the item or your chair is not covered by your warranty.

⚠ WARNING: Please keep hands and equipment away from moving parts that can cause pinch points.

⚠ WARNING: Never operate this product if it has a damaged cord or plug, if it is not working properly, if it has been dropped or damaged, or dropped into water.

⚠ WARNING: Never insert pins or other metallic fasteners into the upholstery of this chair.

⚠ WARNING: Always check the power and handset cords are intact prior to switching the unit on.

⚠ WARNING: NEVER service this chair without unplugging the cord from the wall. Do not put your hands where you cannot see.

⚠ WARNING: Do not crush or pinch heating elements or wiring.

⚠ WARNING: The heat or heat/massage chair must be plugged into a properly grounded outlet and must not be modified in any way. If the three (3) blade plug does not fit your outlet, have one installed that meets your local codes by an electrician. Consult an electrician if you are unsure that the outlets are properly grounded. Do not use a three (3) blade plug to a two (2) blade adapter.

APPENDIX B (continued) – Heated and Heat/Massage Recliners

 **CAUTION:** Make sure all staff involved in the use of the chair has viewed the in-service instruction pages prior to operating the chair. Incorrect use can damage the chair and void your warranty.

 **CAUTION:** Prevent damage to the power cord, do not allow power cord or handset cord to end up under the wheels or other heavy objects. Do not leave power cord close to a source of heat. When removing the power cord from the wall outlet, grasp the plug not the cord.

 **CAUTION:** Do NOT pull this product by the power cord or the handset.

 **CAUTION:** Use this product only for the intended us as described in this manual. Do not use attachments not recommended by the manufacturer.

 **CAUTION:** Clean switch with a moist cloth only, do not allow liquids to pool around the switch.

 **CAUTION:** Do not use with an extension cord.

 **CAUTION:** Take care so cord cannot be pulled or tripped over.

 **CAUTION:** KEEP DRY – Do not operate in a wet condition or environment.

 **CAUTION:** Do not use heat with invalid or unconscious person or occupants who cannot feel if the seat is being too warm.

 **CAUTION:** Keep cord away from heated surfaces.

 **CAUTION:** Do not use outdoors.

 **CAUTION:** Supervision should be provided when this product is used by children, invalids, or disabled persons.

 **CAUTION:** Do not place cord under carpet or in a location where it could become worn.

APPENDIX B (continued) – Heated and Heat/Massage Recliners

POSITIONING THE CHAIR

Please reference previous operation instruction information for all operating instructions for positioning of the chair. This includes the use of the Trendelenburg option if your chair is so equipped.

OPERATING THE HEATER

Uncoil the power cord on the back of the chair and plug it into any properly grounded standard wall outlet. You will find the heater power button on the table of the chair. This will typically be the right table (while seated in the chair) unless other options require it to be on the left side.



Pressing the button the first time will start the heater at low power and all one light will come on. At this setting it will take approximately 16.5 minutes to come to full heat **with an occupant in the chair**. Pressing the button a second time will take the heater to medium power (two lights on) and a third will take it to high (three lights on). To turn the heater off, press the button a fourth time and all of the lights will be out.

NOTE: The heat system is set to turn off 30 minutes after the last button press. Repeat the above process to continue use of the heat feature.

NOTE: If the lights on the switch are flashing, **FIRST unplug the chair from the outlet and check all of the connectors of the heat system**. If a connector is unhooked reconnect it, plug in the power cord, and check the switch again. If all connections appear ok and the lights still flash, unplug your chair and contact Champion's customer service. This does not affect the basic functions of the chair.

APPENDIX B (continued) – Heated and Heat/Massage Recliners

MESSAGE OPERATION

Uncoil the power cord on the back of the chair and plug it into any standard wall outlet. You will find the message buttons on the table of the chair. This will typically be the right table (while seated in the chair) unless other options require it to be on the left side.

NOTE: The heat and massage options can be used independently of each other. Refer to previous section for instructions on how to operate the heater in the heat/massage recliner.



MESSAGE FUNCTION: The message switch function is controlled by repetitively pressing the message button. The first button push will turn on the message light, and it will remain on through the button press cycle until the massage system is off.

BUTTON PRESS SEQUENCE

1. Lower Zone, Low Intensity
2. Lower Zone, High Intensity
3. Full Back, Low Intensity
4. Full Back, High Intensity
5. System Off

NOTE: The massage system is set to turn off fifteen (15) minutes after the last button push. If the occupant wishes to continue using the massage simply repeat the above steps.

NOTE: If the lights on the switch are flashing, **FIRST unplug the chair from the outlet and check all of the connectors of the heat system.** If a connector is unhooked reconnect it, plug in the power cord, and check the switch again. If all connections appear ok and the lights still flash, unplug your chair and contact Champion's customer service. This does not affect the basic functions of the chair.

APPENDIX B (continued) – Heated and Heat/Massage Recliners

MAINTENANCE

 **WARNING:** Before performing any cleaning or maintenance to the heat or heat/massage chair make sure that it is unplugged from the outlet. This will prevent a shock hazard while working inside the chair.

 **CAUTION:** DO NOT allow moisture to pool on top of the switch.

 **CAUTION:** DO NOT pressure wash or “hose down” chairs.

 **CAUTION:** Heat or heat/massage components are fixed to the inside of the removable seat cushion. The seat can be slid forward as described on a previous diagram BUT must be flipped up and placed in the chair. This allows the seat to be moved for access to the inside of your recliner without having to remove any components.

Please reference section on General Maintenance and Care of Chairs. Please wipe up all spills as soon after they happen as possible. Use caution when cleaning around any of the cord connections in the power components.

Make sure to wipe all moisture out of switch area after all cleaning.

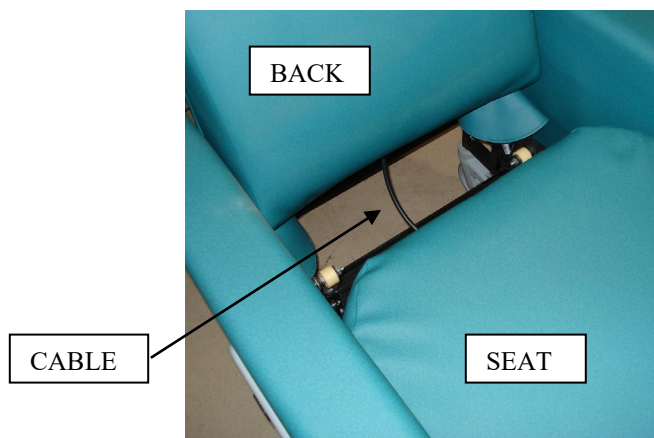

Note: Some components may have a different appearance as shown in the picture due to multiple models of chairs. The serial number of the chair informs Customer Service of the proper components for that chair.

APPENDIX B (continued)

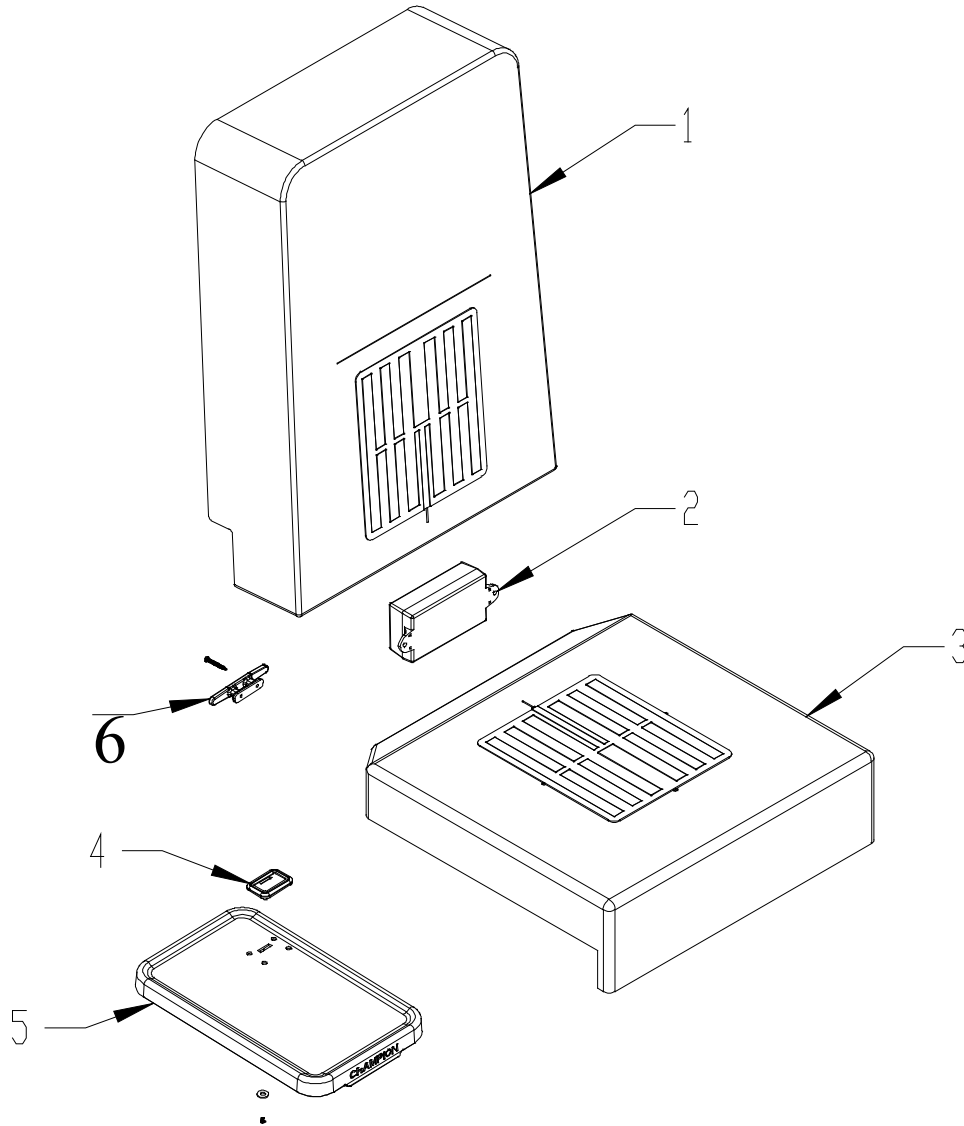

HEAT AND HEAT/MASSAGE CHAIR COMPONENTS LIST

PG/PART	DESCRIPTION	PG/PART	DESCRIPTION
40-01	BACK FOAM W/ HEAT OR HEAT & MASSAGE	40-06	CORD CLEAT
40-02	CONTROL BOX	40-11	POWER CORD (NOT SHOWN)
40-03	SEAT FOAM W/ HEAT	40-12	SWITCH CABLE (NOT SHOWN)
40-04	SWITCH ASSEMBLY	40-13	MASSAGE MOTOR EXTENSION CBL (NOT SHOWN)
40-05	PLASTIC TABLE		

Note: Some components may have a different appearance than shown in the picture due to multiple models of chairs. The serial number of the chair informs Customer Service of the proper components for that chair.