

# Operation Manual

V1.0

## AutoMATE™ 96 Microplate Pipetting Workstation

### MP9604



**This Product is for Research Use Only**



Thank you for purchasing the AutoMATE™ 96 Microplate Pipetting Workstation. This user manual details the instrument's features, specifications, as well as complete operating instructions; please read it carefully before operation. Keep this user manual for later use.

**Important:**

**Please keep the box and packaging material for this instrument. If service is required, the box will be needed to ship the instrument to our Service Department.**

**Initial Inspection**

Please inspect the instrument as well as all included accessories when you first open the packaging. If you find anything damaged or missing, please contact Benchmark Scientific or your local distributor immediately.

**BENCHMARK SCIENTIFIC / ACCURIS INSTRUMENTS**

# Safety Warnings and Guidelines

## 1. Important information for safe use

Users should understand how to use this instrument before operating. Please read this manual carefully prior to operation.



Any improper operation may cause injury. Please read this manual carefully and operate safely according to the guidelines.

## 2. Operation and Maintenance

The operation and maintenance of the instrument should comply with the basic guidelines and warnings below. Incorrect operation or maintenance will have detrimental effects on the life, performance, and safety features of the instrument.



The instrument is a normal indoor instrument which conforms to class I of the GB 4793.1 standard.



This instrument is designed for use in a laboratory environment. The device must be operated by skilled laboratory personnel with appropriate training.



To prevent injury or voiding the warranty, the operator should not attempt to repair the instrument without explicit guidance from Accuris Instruments. If service is required, please contact Accuris Instruments or your local distributor for repair.



Before powering on, confirm that the voltage used meets the electrical requirements of the instrument as stated on the rating plate. If the electric cord is damaged, replace it with the same type of cord. Hold the socket firmly before pulling the plug from an outlet. Do not pull the electric cord.



The temperature of the heating block can be high; please do not touch it while it is in use to prevent injury.



The instrument should be installed in an environment of standard room temperature, low dust, low humidity, and away from direct sunlight, electromagnetic interference, and heat sources. Do not block the vents on the instrument.



Always power off the instrument when you are finished using it. Unplug the power cord and cover the instrument with a cloth or plastic sheet to prevent excessive dust from entering the housing.



Pull the connector plug from the electrical outlet immediately and contact the vendor in the event of:

- Liquid entering the housing.
- Abnormal operation: such as any abnormal sound or smell.
- The instrument is dropped or there is any damage to the housing.
- Any malfunction.

### **3. Maintenance**

The instrument should be cleaned regularly using a soft cloth dampened with a small amount of alcohol.

### **4. Transportation and storage requirements**

Ambient temperature:  $-20^{\circ}\text{C} \sim 55^{\circ}\text{C}$

Relative humidity:  $\leq 80\%$

Place in a well-ventilated room, away from corrosive gas.

# Table of Contents

<b>Chapter 1 Introduction</b> .....	1
1. Key Features.....	1
<b>Chapter 2 Specifications</b> .....	2
1. Required Installation Environment .....	2
2. Instrument Specifications.....	2
3. Pipetting Head Specifications.....	3
<b>Chapter 3 Instrument Overview</b> .....	4
1. Structure .....	4
2. Dimensions .....	5
<b>Chapter 4 Instrument Setup</b> .....	6
1. Preparation Before Use .....	6
2. Pipette Head Installation / Replacement .....	7
3. 384-Well Microplate Pipetting.....	8
<b>Chapter 5 Programming &amp; Operation</b> .....	9
2. Software Initialization .....	9
3. App Main Interface.....	10
4. Manual Mode.....	11
5. Automated Program Mode .....	15
6. Protocol Management / Settings .....	22
7. System Settings.....	28
8. Labware Management.....	34
<b>Chapter 6 Maintenance</b> .....	36
1. Suggested Maintenance Tools .....	36
2. Daily Maintenance .....	36
3. Regular Maintenance .....	36
4. Annual Maintenance.....	37
5. Pipetting Head Replacement / Calibration .....	37
<b>Chapter 6 Troubleshooting</b> .....	38

# Chapter 1 Introduction

The **AutoMATE™ 96** from Accuris Instruments is a fully automated, high throughput liquid handling workstation that improves productivity when filling microplates. Capable of dispensing up to 96 channels simultaneously, the AutoMATE 96 significantly reduces the processing time and errors associated with manual pipetting.

The included tablet features an intuitive app for programming and operation. Unlike many 96-well pipetting stations, the AutoMATE 96 is “hands-free”, with motorized tip loading/ejection and a four position, automated, sliding platform that precisely aligns the tips with the appropriate microplate/reservoir. Once programmed, the instrument can run protocols to completion without any manual positioning or adjustment.

Three interchangeable heads allow for a pipetting range from 1.0µL to 1000µL. The AutoMATE 96 is compact enough to fit onto a standard lab bench or into a biosafety cabinet.

## 1. Key Features

- Precise pipetting - The pipetting range can be selected according to the specific requirements.
- Multiple pipetting functions - sample transfer, gradient dilution, plate replication, combining samples from multiple plates, 96/384 plate conversion and more.
- 4 position platform: Select tip, plate, and reservoir positions. Program automatic movement of the platform.
- Easy to use - Intuitive interface for manual and programmed operations.

# Chapter 2 Specifications

## 1. Required Installation Environment

Environmental Temperature: -20°C - 55°C

Operating Temperature: 10°C – 40°C

Relative Humidity: ≤ 80%

Atmospheric Pressure: 86.9 kPA – 106.0 kPA

Input Voltage: AC 100~240V, 50Hz/60Hz

## 2. Instrument Specifications

<b>Model</b>	<b>AutoMATE™ 96 (MP9604)</b>
<b>Pipetting Heads</b>	20ul, 200ul, 1000ul (interchangeable)
<b>Platform positions</b>	Four
<b>Plate positioning</b>	Automatic / motorized
<b>Operation interface</b>	Tablet, basic manual operation and programmed operation
<b>Channels</b>	8 / 96
<b>Compatible Tips</b>	Accuris AutoMATE tips
<b>Operating</b>	Android
<b>Display</b>	8 inch tablet, color display
<b>Instrument port</b>	USB B
<b>Power supply</b>	100 to 240VAC, 50/60Hz, 100W
<b>Tablet connection</b>	Bluetooth
<b>N.W.(KG)</b>	32.6 Kg
<b>Size(WxDxH)mm</b>	69.0x35.0x67.3 cm

### 3. Pipetting Head Specifications

Pipette Head	MP9600-20PH (20 $\mu$ L)	MP9600-200PH (200 $\mu$ L)	MP9600-1000PH (1000 $\mu$ L)
Number of pipetting channels	96	96	96
Pipetting range/ $\mu$ L	1~20	5~200	100~1000
Pipetting accuracy	1 $\mu$ L: $\leq\pm 12\%$	5 $\mu$ L: $\leq\pm 5\%$	100 $\mu$ L: $\leq\pm 2.5\%$
	2 $\mu$ L: $\leq\pm 5\%$	20 $\mu$ L: $\leq\pm 2\%$	500 $\mu$ L: $\leq\pm 1\%$
	10 $\mu$ L: $\leq\pm 1\%$	100 $\mu$ L: $\leq\pm 1\%$	1000 $\mu$ L: $\leq\pm 1\%$
	20 $\mu$ L: $\leq\pm 1\%$	200 $\mu$ L: $\leq\pm 1\%$	
Pipetting precision	1 $\mu$ L: $\leq 10\%$	5 $\mu$ L: $\leq 3.5\%$	100 $\mu$ L: $\leq 1.25\%$
	2 $\mu$ L: $\leq 5\%$	20 $\mu$ L: $\leq 1.5\%$	500 $\mu$ L: $\leq 0.4\%$
	10 $\mu$ L: $\leq 1\%$	100 $\mu$ L: $\leq 0.8\%$	1000 $\mu$ L: $\leq 0.4\%$
	20 $\mu$ L: $\leq 0.8\%$	200 $\mu$ L: $\leq 0.4\%$	

# Chapter 3 Instrument Overview

## 1. Structure

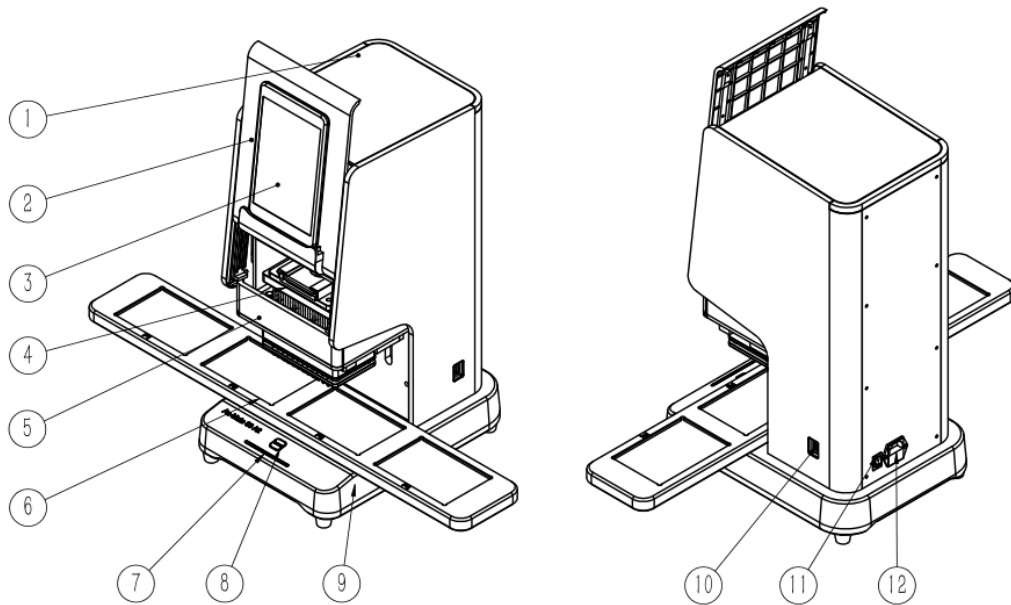


Fig 1. AutoMATE 96 Structure

- 1) Shell
- 2) Front Casing
- 3) Tablet
- 4) Pipetting Head
- 5) Front Plate
- 6) Motorized Platform
- 7) Operational LED Indicator
- 8) SWITCH (STOP) Key
- 9) Base
- 10) USB Port
- 11) Power Switch
- 12) Power Inlet

## 2. Dimensions

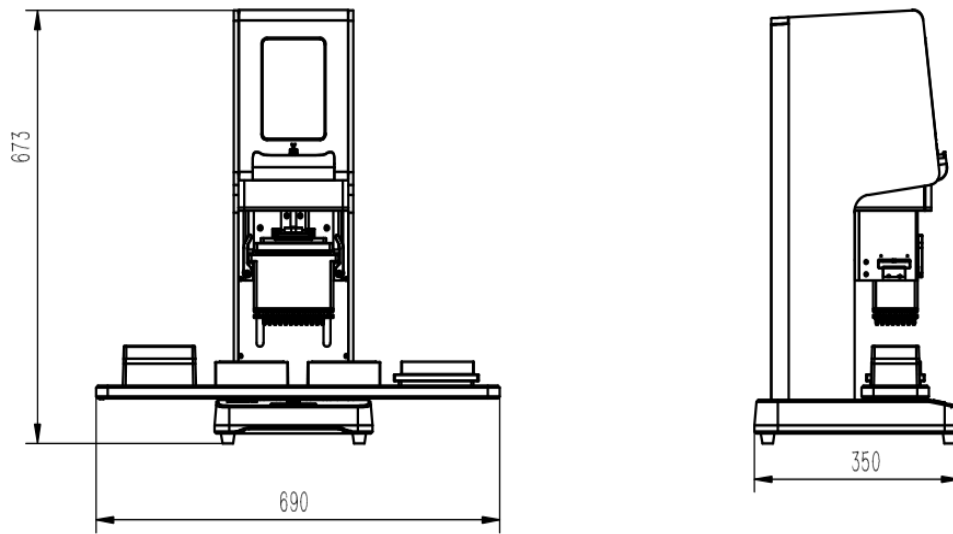


Fig 1. Dimensions

# Chapter 4 Instrument Setup

## 1. Preparation Before Use

An experienced laboratory technician, with the requisite knowledge and background, should be the one to unpack and install the instrument. The technician should thoroughly examine all items that arrive with the instrument and compare them to the Packing List. Should there be any doubts or questions about the instrument or its accompanying accessories, such should be recorded and Accuris Instruments or the relevant distributor should be contacted.

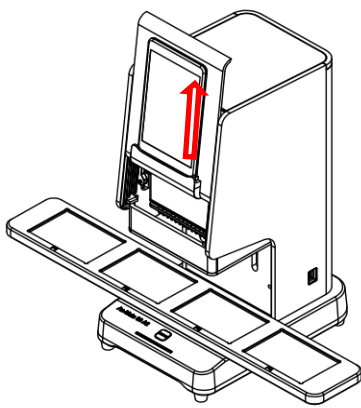
Before beginning any pipetting process, the following checklist should be completed:

- Confirm that the tablet controller is connected to the instrument.
- Ensure that there are no obstructions to the moving platform and that it moves freely to both the right and left.
- Verify that the power supply connected to the instrument is steady and meets the power supply requirements: Voltage: 100~240V ( $\pm 10\%$ ); Frequency: 50Hz/60Hz.
- Turn on the main power switch, as depicted in Figure 5, to the "I" position. Confirm that the instrument is powered on and that the Operational Indicator Light is lit.

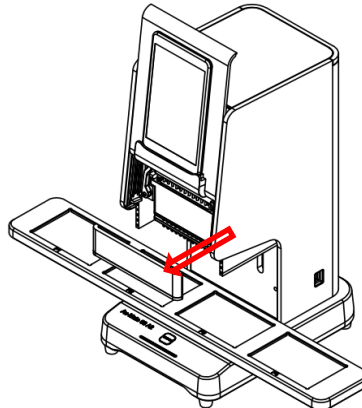


Fig 2. Power Switch

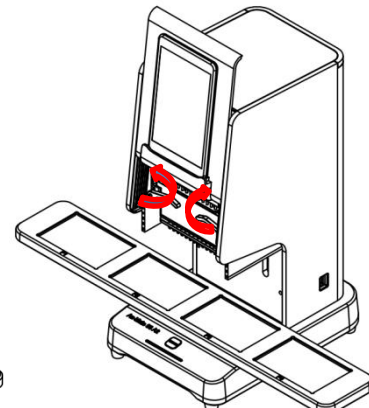
## 2. Pipette Head Installation / Replacement



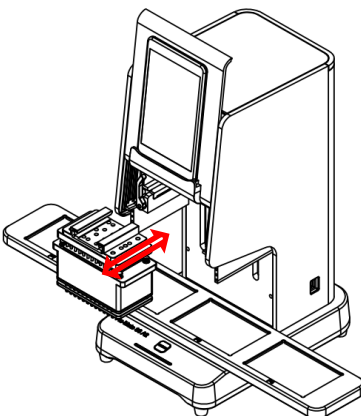
① Push front casing up



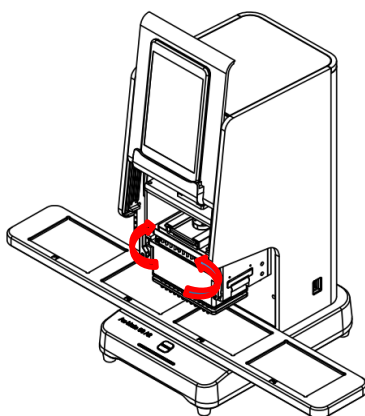
② Remove the front edge



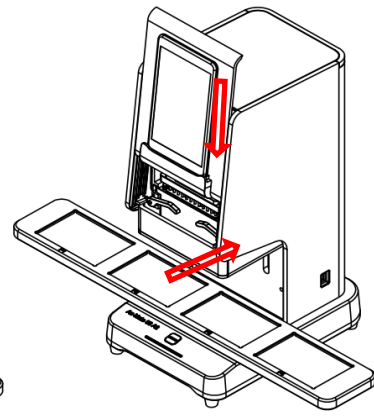
③ Loosen the locking levers



④ Replace pipetting head



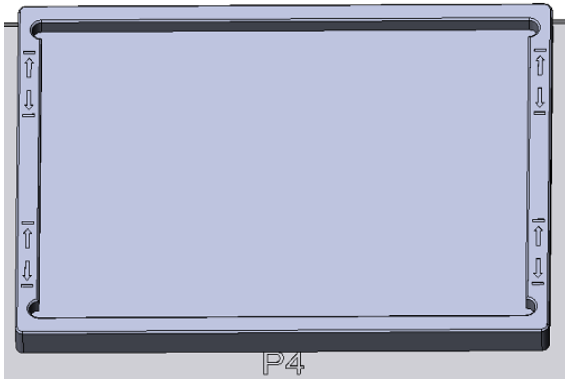
⑤ Tighten levers



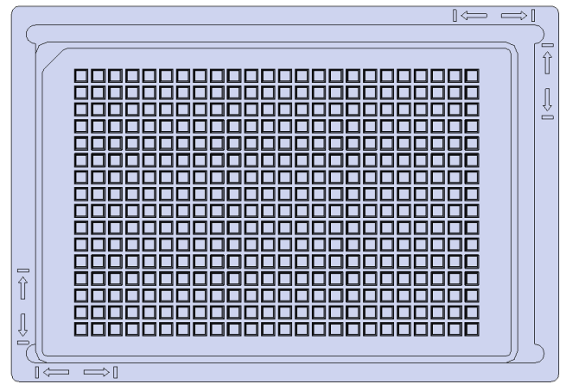
⑥ Replace front casing & front edge

Fig 3. Pipette Head Replacement

### 3. 384-Well Microplate Pipetting



384-well Microplate Adapter



384-well Microplate Positioning

Place the 384-well microplate adapter onto a platform position. Place the 384-well microplate onto the bottom left side of the adapter. During a program run, the AutoMATE 96 will dispense into two horizontal positions, and then instruct the user to move the 384-well microplate to the top left side of the adapter to dispense into the final 2 horizontal position

# Chapter 5 Programming & Operation

## 1. Software Initialization

On the included Android Tablet, select the “AutoMATE™ 96” app icon to enter the application interface.



Fig 3. AutoMATE™ 96 App Icon

Select the user (Admin or other), enter the corresponding user password, and click “Login” to enter the main interface, as shown in the figure below.

**Note:** The initial Admin account password is set to “0000”. The password can be changed via the system settings (**Chapter 5.8**).

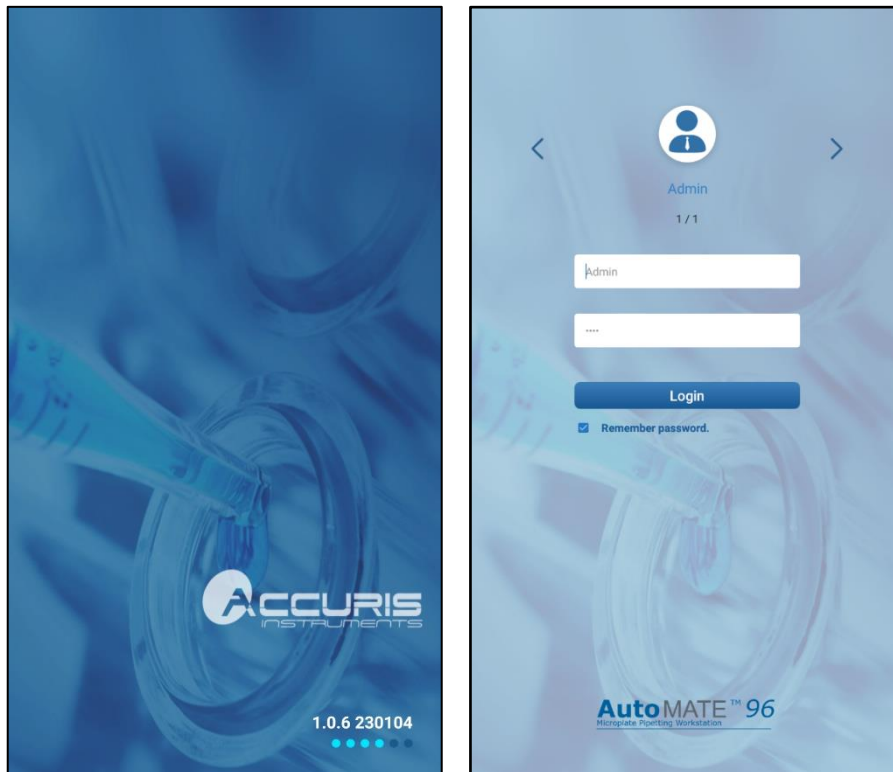
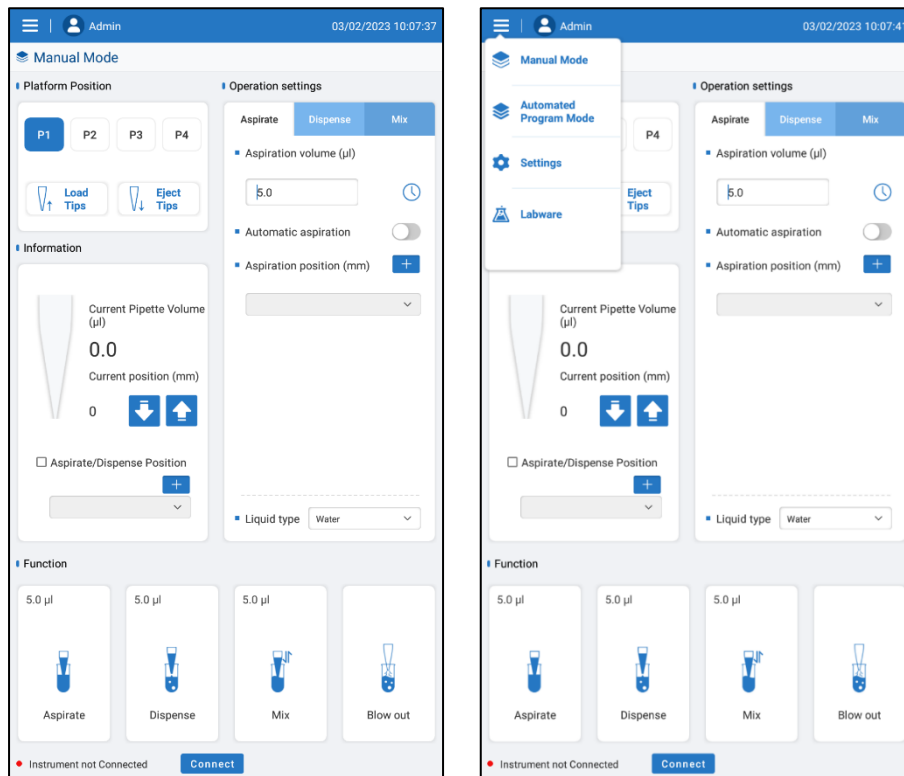


Fig 4. Login interface

## 2. App Main Interface

After logging in, the main interface will display (**Figure 8**). On the main interface, choose one of the two pipetting modes: **Manual Mode** or **Automated Program Mode**, as shown in the figure below.



**Fig. 5 AutoMATE™ 96 Application Main Interface**

### 3. Manual Mode

Choose "Manual mode" to enter the basic mode, as shown in the figure below.

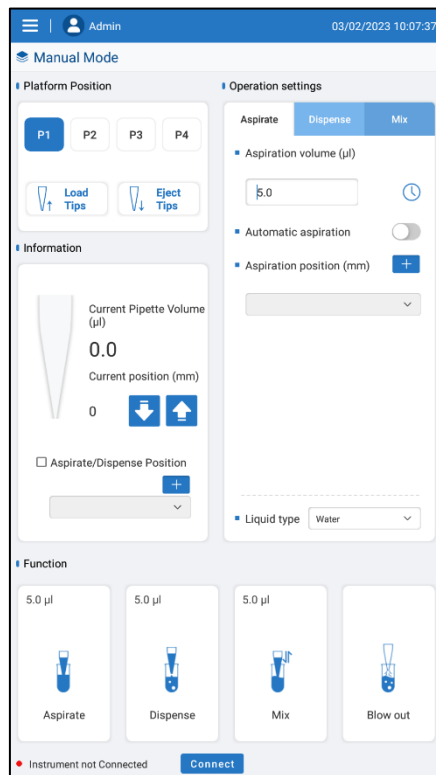


Fig. 6 Manual Mode Interface

#### Platform Positions:

The motorized platform has four positions: P1 corresponds to platform position 1, P2 corresponds to platform position 2, and so on. To change to another platform in the Manual Mode Interface, select a different platform position to highlight it blue (**Figure 10**); the instrument will automatically position itself to the platform position specified.



Fig. 7 Platform Position Selection

#### Tip Loading & Ejection

To load / eject pipette tips in the Manual Mode Interface, select the "Load Tips" or

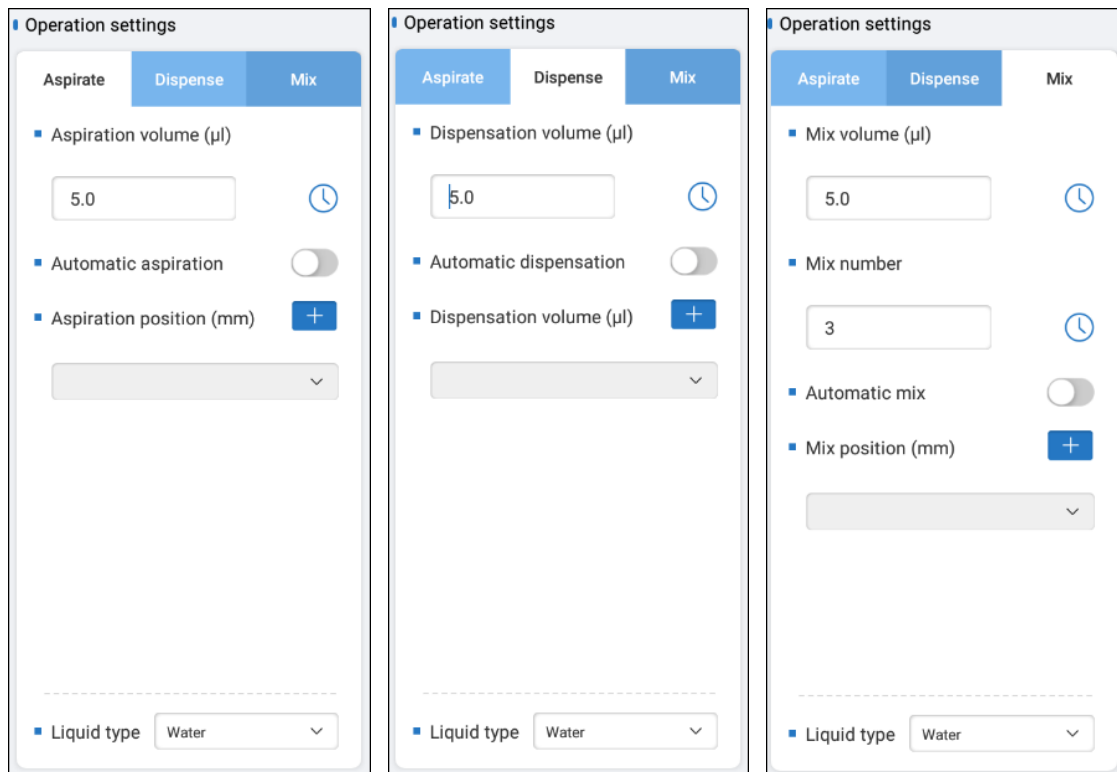
“Eject Tips” icons to highlight it blue (**Figure 11**); the instrument will automatically load / eject tips to the currently selected platform position.



**Fig. 8 Manual Mode: Tip Loading & Ejection**

## Pipetting Functions

In the Manual Mode Interface, users can toggle amongst settings for “Aspirate” , “Dispense”, and “Mix” (**Figure 12**).



**Fig 9 Manual Mode: Pipetting Functions**

**Table 1 Legend: Manual Mode Pipetting Functions**

Aspiration volume (µL)	Click the Aspirate volume text box, enter the volume of liquid to be aspirated.
Dispensation volume (µL)	Click the Dispense volume text box, enter the volume of liquid to be dispensed.
Mix volume (µL)	Click the Mix volume text box, enter the volume of liquid to be mixed.
Automatic aspiration	Click <input type="checkbox"/> on/off for the automatic aspiration function
Automatic dispensation	Click <input type="checkbox"/> on/off for the automatic dispensation function
Automatic mix	Click <input type="checkbox"/> on/off for the automatic mix function
Mix number	Click the Mix number text box, enter the # of mixing steps to be performed (Range: 0-99).
Aspiration position (mm)	Click <input type="button" value="+"/> to create a new aspirate position, or click the drop-down menu to choose an available aspiration position.
Dispensation position (mm)	Click <input type="button" value="+"/> to create a new dispense position or click the drop-down menu to choose an available dispensation position.
Mix position (mm)	Click <input type="button" value="+"/> to create a new mix position or click the drop-down menu to choose an available mix position.
Liquid type	Click the drop down to select the liquid type of the sample (Water, Alcohol, Lysis Buffer, Magnetic Beads, etc.).

Positions for aspirate, dispense and mix refer to position location of the bottom of the tip as measured vertically from the top surface of the platform. The position may need to be adjusted depending on the volume of liquid in the microplate/reservoir and the design of the microplate/reservoir. Settings for Automatic aspiration/dispensation/mix allow the user to create or select a position for the automation. Once a function key is selected with automatic aspiration turned on, the instrument will automatically perform aspiration at the specified position.

## Manual Mode: Function Keys

As shown in the figure below, there are four Function Keys available : Aspirate, dispense, Mix and Blow out. The current set volume is shown in the upper left corner of each Operation button. If the Operation Setting has been set with automatic aspiration/dispense/mix with a position (mm) set, this set position will also be displayed in the upper left corner. If there is no position setting, the position data will not be displayed.

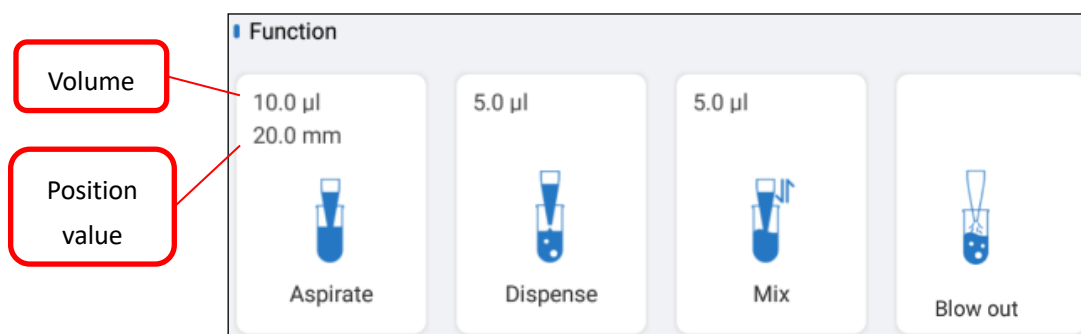





Fig. 10 Manual Mode: Function Keys

## Real Time Information

In the Manual Mode Interface, real-time information of the pipette tips, such as the volume of liquid in the tips and position of the tips, can be seen. Below   , the position of the tip can be manually adjusted according to the current position. Highlight the “Aspirate/Dispense Position” box to enable automatic aspiration / dispensation to the set descent position. To add descent position, click  of Aspirate / Dispense Position.

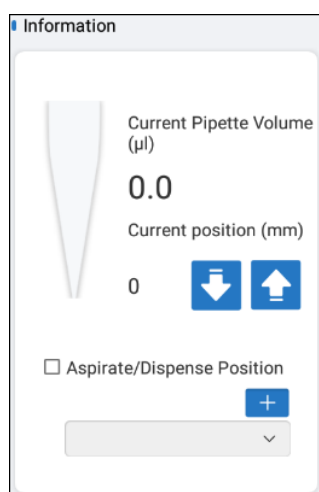
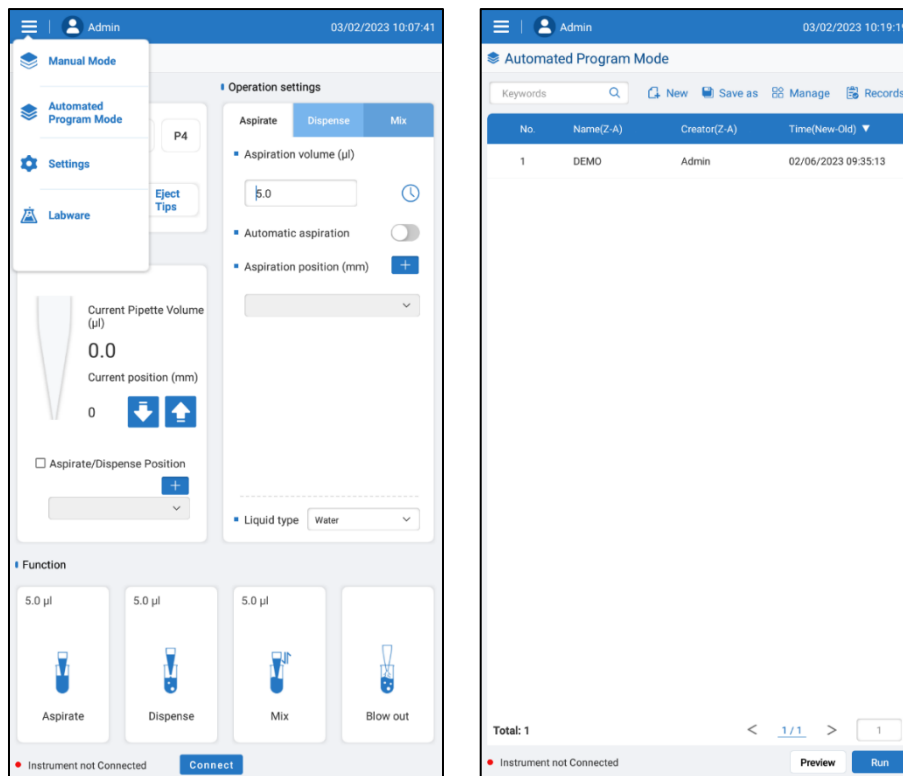


Fig. 11 Manual Mode: Real Time Information

## 4. Automated Program Mode

Choose “Automated Program Mode” from the upper left menu to enter the Automated Program Mode, as shown in the figure below.

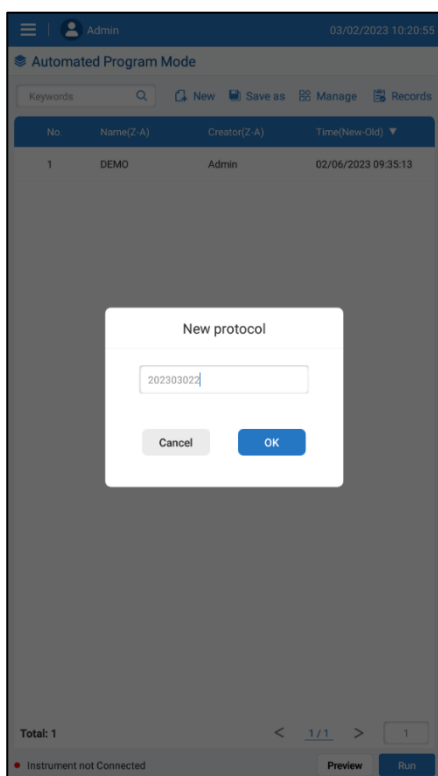


**Fig 12 Automated Program Mode Interface**

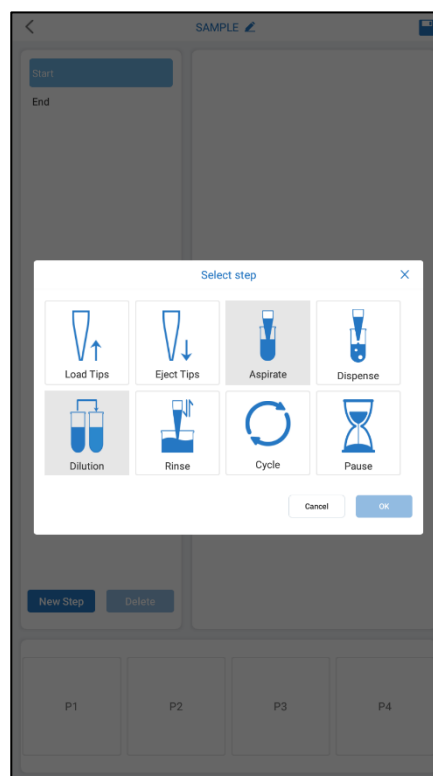
The Automated Program Mode offers four function buttons at the top right: New, Save as, Manage and Records.

### Creating a New Program

Press the “New” button to create a new program. The default program name is the numerical combination of the current date and time (see Fig 14 Select step), click on this number to change the name if desired, then press OK to start the programming. Press “New Step” at the lower left and the “Select step” window will open. Press to highlight the type of step to add to the program, and click OK.

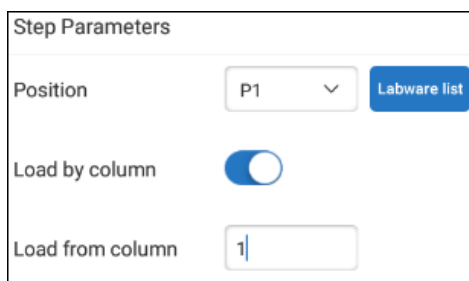


**Fig 13 New protocol**



**Fig 14 Select step**

The “Step Parameters” for the newly added step can now be set. Select a Position for the step (P1 to P4). Typically, “Load Tips” would be the first step, and for this the tips are usually positioned the at P1 (far left) position of the platform. Select the platform position P1.

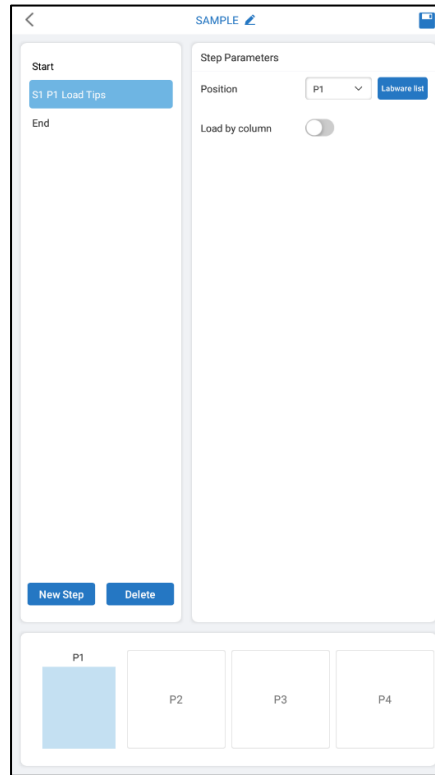


**Figure 16 Step Parameters**

Next, press the “Labware list” button to choose the appropriate tips to load, ( Fig ); Or, if pipetting with only a column of 8 tips, for a process such as serial dilution, choose “Load by column”. Choose the column of tips (1 to 12) which is to be loaded on the left most column of the pipetting head. See figure x. Unloading tips carry the same parameters as loading tips, but for tip ejection.



**Fig 17 Labware list**



**Fig 18 S1 P1 Load Tips**

After setting up the step parameters, click on “New Step” to add another step. The program can be saved by pressing the disk icon in the upper right of the screen. Steps can be modified by pressing any of the created steps in the upper left.

## Automated Program Mode: Aspirate & Dispense Settings:

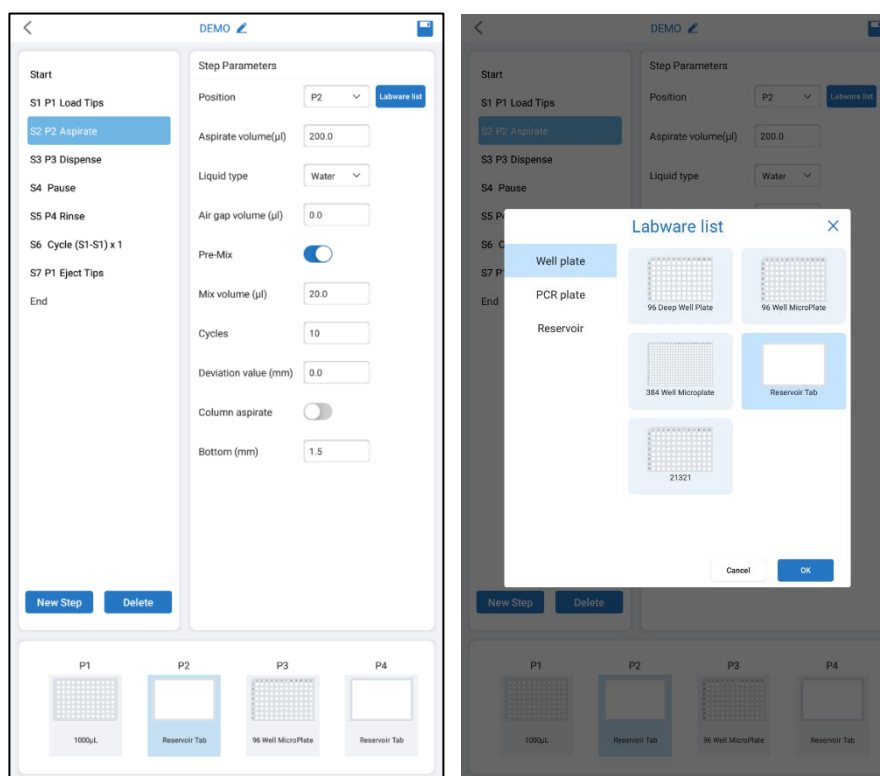


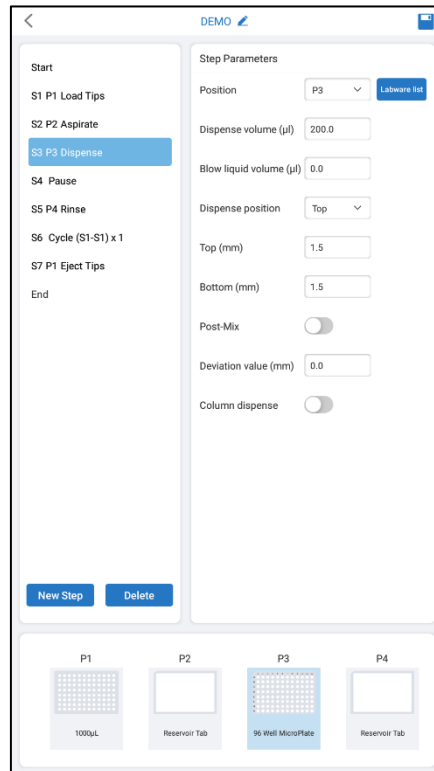
Figure 19 Aspirate & Dispense Settings

### Aspiration Step Parameters:

The following settings are available and adjustable for the aspiration steps:

- **Position:** Platform position (P1 – P4)
- **Labware List:** Select from which plate aspiration will occur (96 deep well plate, reagent reservoir, etc.)
- **Aspirate Volume (µL):** The set volume for aspiration
- **Liquid Type:** Adjust aspiration rate by selecting a pre-programmed settings (Water, alcohol, lysis buffer, magnetic beads, etc.)
- **Air Gap Volume (µL):** The volume of air aspirated after liquid aspiration
- **Pre-Mix:** Toggle to enable mixing of the reagent prior to aspiration
  - **Mix Volume (µL):** The volume of the reagent that will be mixed prior to complete aspiration
  - **Cycles:** The # of pre-mix cycles performed prior to complete aspiration
- **Deviation Value:** Adjust the vertical positioning of the point of aspiration. This feature does not require input if performing basic aspiration from the selected Labware List.
- **Column Aspirate:** Toggle to enable column aspiration. Note: this feature is only available when “Column Load” is toggled on in the Load Tips step (see **Figure 18**).

- **Bottom (mm):** Adjust how far the tips are placed from the bottom of the labware used when performing aspiration.



**Figure 20 Dispense Settings**

### Dispensation Step Parameters:

The following settings are available and adjustable for the dispensation steps:

- **Position:** Platform position (P1 – P4)
- **Labware List:** Select from which plate dispensation will occur (96 deep well plate, reagent reservoir, etc.)
- **Dispense Volume (µL):** The set volume for dispensation
- **Blow Liquid Volume (µL):** The set volume for blowing out residual liquid in the pipette tips after performing dispensation
- **Dispense Position:** Select where dispensing will occur: “Top” or “Bottom”
- **Top (mm):** Adjust How far from the top of the dispense position selected the AutoMATE 96 will dispense
- **Bottom (mm):** Adjust How far from the bottom of the dispense position selected the AutoMATE 96 will dispense
- **Post-Mix:** Toggle to enable mixing of the reagent post-dispensation
  - **Mix Volume (µL):** The volume of the reagent that will be mixed after dispensation
  - **Cycles:** The # of post-mix cycles performed after completing

dispensation

- **Deviation Value:** Adjust the vertical positioning of the point of aspiration. This feature does not require input if performing basic aspiration from the selected Labware List.
- **Column Dispense:** Toggle to enable column dispensation. Note: this feature is only available when “Column Load” and “Column Aspirate” are toggled on in the Load Tips / Aspiration steps (see **Figures 18 & 19**).

### Automated Program Mode: Pause & Rinse Settings:

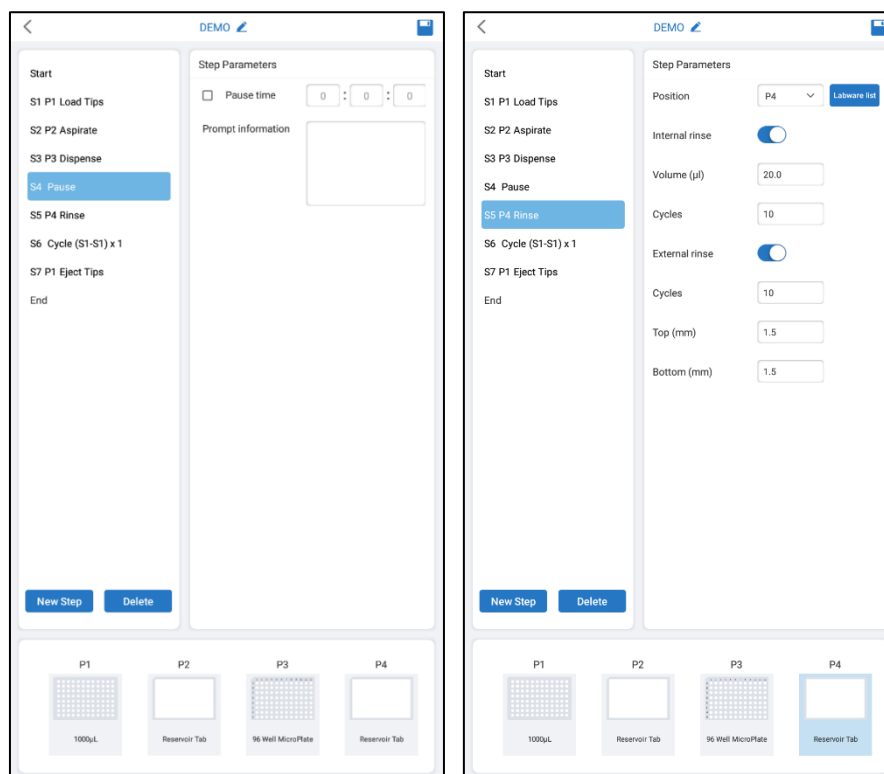


Figure 21 Pause & Rinse Settings

### Pause Step Parameters:

The following settings are available and adjustable for the pause step:

- **Pause Time:** Toggle to enable a time-based pause step. Time can be adjusted based on the following format: Hours : Minutes : Seconds (eg. 10:15:20 would correspond to a pause time of 10 hours, 15 minutes, & 20 seconds).
- **Prompt Information:** Input the set of text to display when the program has reached the Pause step

**Note: Do NOT** toggle pause time to the on position if the pause step requires user confirmation prior to proceeding to the next step(s).

## Rinse Settings:

The following settings are available and adjustable for the rinse step:

- **Position:** Platform position (P1 – P4)
- **Labware List:** Select from which plate rinsing will occur (96 deep well plate, reagent reservoir, etc.)
- **Internal Rinse:** Toggle to enable internal rinsing of the pipette tips
  - **Volume (µL):** The volume of the reagent used to perform an internal rinse
  - **Cycles:** The # of internal rinses performed
- **External Rinse:** Toggle to enable external rinsing of the pipette tips
  - **Cycles:** The # of external rinses performed
- **Top (mm):** Adjust How far from the top of the Rinse position selected the AutoMATE 96 will perform internal/external rinsing.
- **Bottom (mm):** Adjust How far from the bottom of the Rinse position selected the AutoMATE 96 will perform internal/external rinsing.

## Automated Program Mode: Cycle Settings:

The screenshot displays the 'Cycle Settings' interface. On the left, a list of steps is shown, with 'S6 Cycle (S1-S1) x 1' highlighted. On the right, the 'Step Parameters' section is visible, containing three input fields: 'From Step' (set to 2), 'To Step' (set to 5), and 'Repeat' (set to 1). At the bottom, there are four platform icons labeled P1, P2, P3, and P4. Below each icon is a labware selection: P1 is '1000µL', P2 is 'Reservoir Tub', P3 is '96 Well MicroPlate', and P4 is 'Reservoir Tub'. There are also 'New Step' and 'Delete' buttons at the bottom left of the main panel.

Figure 22 Cycle Settings

## Cycle Step Parameters

The following settings are available and adjustable for the cycle step:

**From Step:** Select from which step the cycle will begin from.

**To Step:** Select which step the cycle will end on.

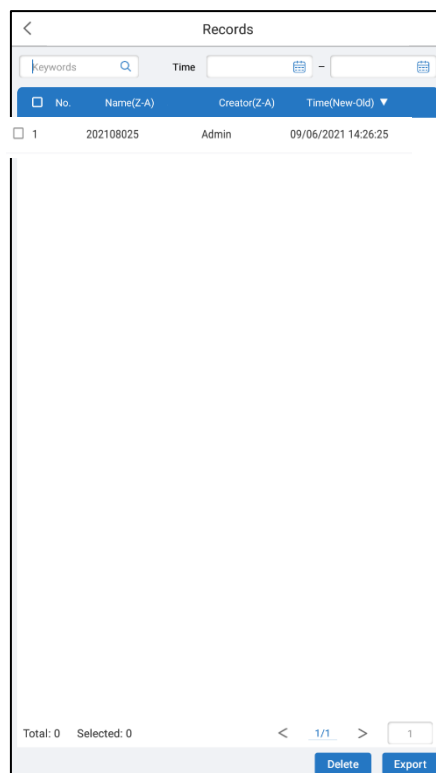
**Repeat:** Input the # of times the cycle step will perform

Example:

- From Step: 1
- To Step: 5
- Repeat: 3

Once the program reaches the cycle step, it will repeat steps 1-5 for a total of 3 times before proceeding to the next step.

## 6. Protocol Management / Settings



**Fig 25 Record interface**

## Protocol Preview

To **Preview** the detailed steps of a saved protocol, users can highlight the protocol and click the **Preview** button (as shown in Figure 37). From the preview screen, the user can click the **Run** button to start the protocol or press the < icon at the top left of the screen to return to the protocol list screen. Additionally, users may also be able to control the settings of the protocol from this screen, including the name and accessibility.

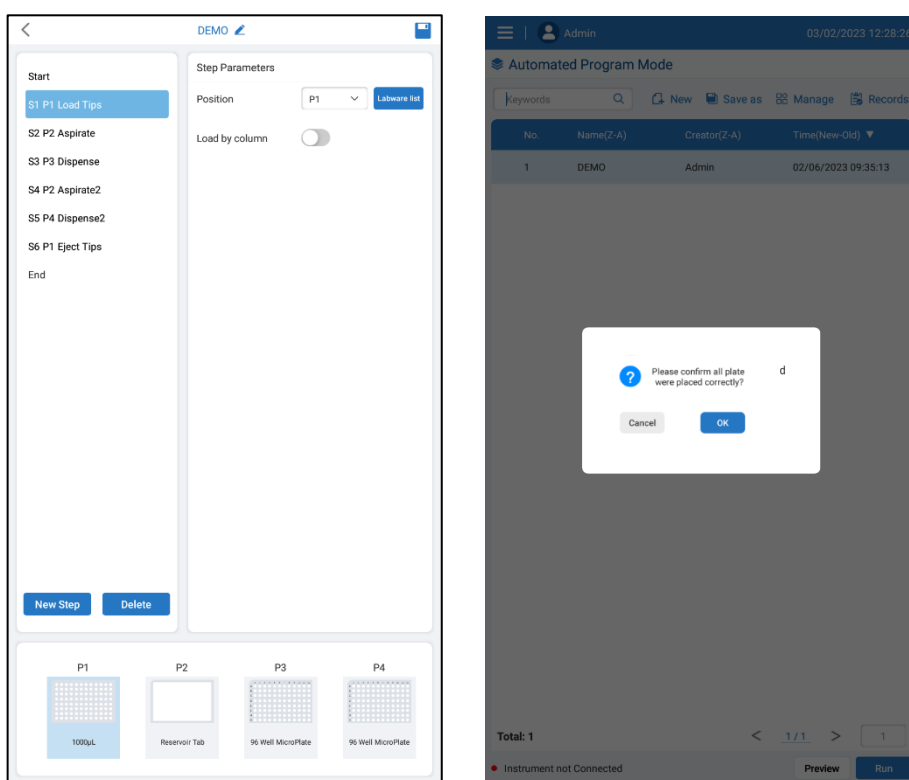
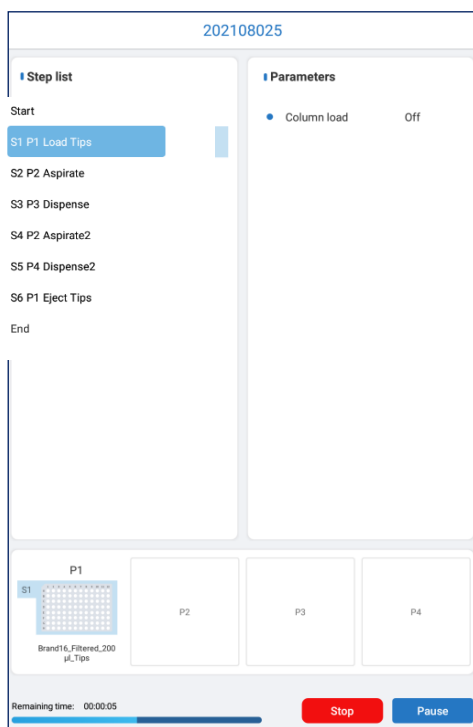


Fig 26 Preview protocol interface Fig 15 Confirm prompt box before running

## Running a Protocol

From the protocol list screen (Figure 20), click to highlight a single protocol, then click the “Run” button. A window will appear to confirm all consumables are placed properly before starting the run.



**Fig 28 Run Interface**

### **Stop / Pause a Run in Progress**

During a protocol run, the user can **Stop** the process by clicking the **Stop** button. A window will appear to confirm the stopping of the run (as shown in Figure 40) and clicking **OK** will stop the current protocol. The pipetting head and motorized platform will return to the home position. To **Pause** a run, the user can press the **Pause** button. The run can then be resumed by pressing **Continue** or stopped by pressing **Stop**. Additionally, users may also be able to view the progress of the run from this screen.



**Fig 61 SWITCH button**

The SWITCH button is located on the base of the instrument and has the following functions:

1. In Manual Mode, the switch button is used to Aspirate and Dispense. If the current

Pipette Volume is 0.0 (no liquid in the tips) then the SWITCH button will activate aspiration. If the Current Pipette Volume is >0.0 (there is liquid in the tips) then the SWITCH button will activate dispensing.

2. In Automated Program Mode, the function of the SWITCH button can be used to start a run (same as Run button), and when a program is running the SWITCH button can be used to Pause the run.

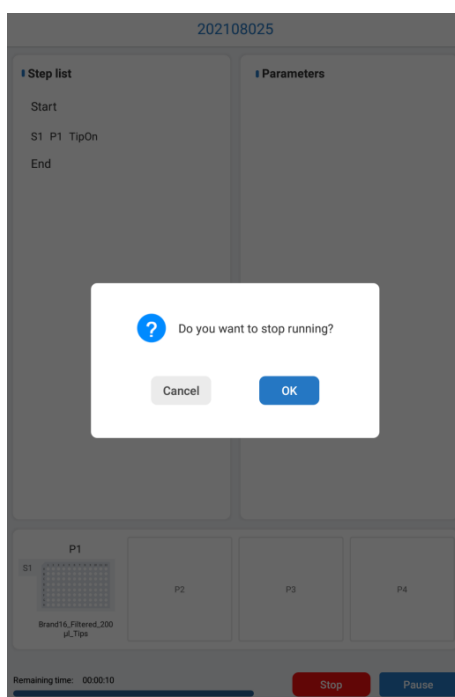


Fig 29 Stop prompt box

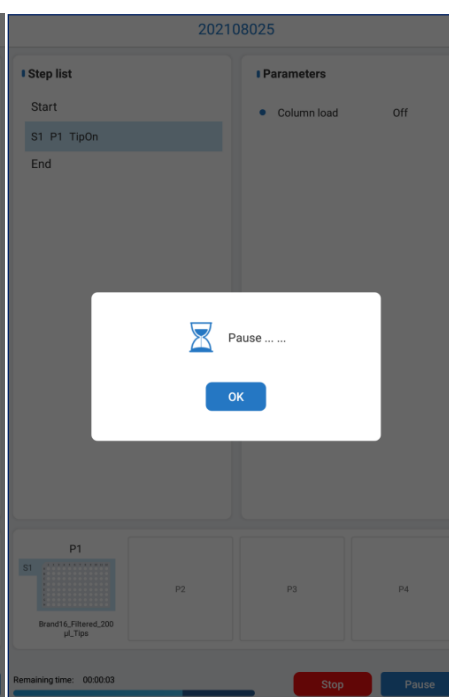
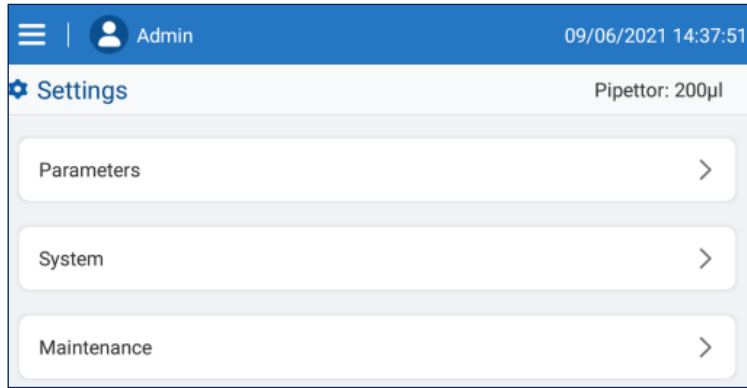


Fig 30 Pause prompt box

## 7. System Settings

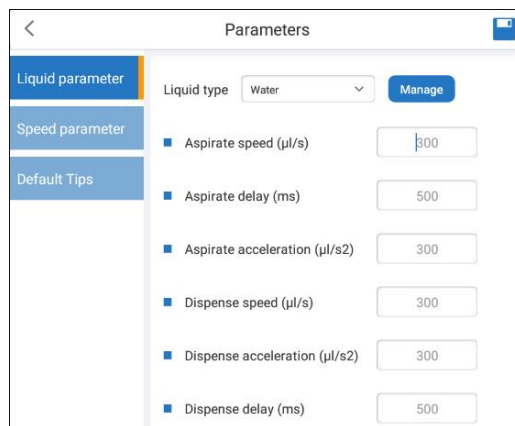
The Settings mode can be selected from the upper left menu. The settings interface includes three sections: parameter, system and maintenance.



**Fig 31 Settings**

### Parameter Settings – General Interface

Parameters setting allows adjustments to Liquid parameter, Speed parameter and Default tips, as shown in the figure below.

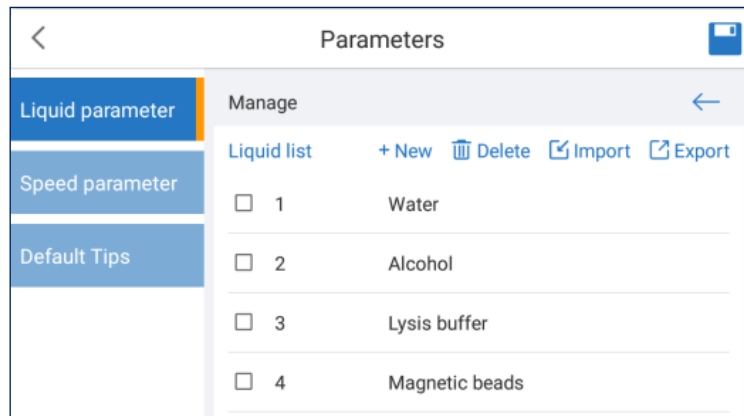


**Fig 3216 Parameter interface**

Liquid Parameter Settings:

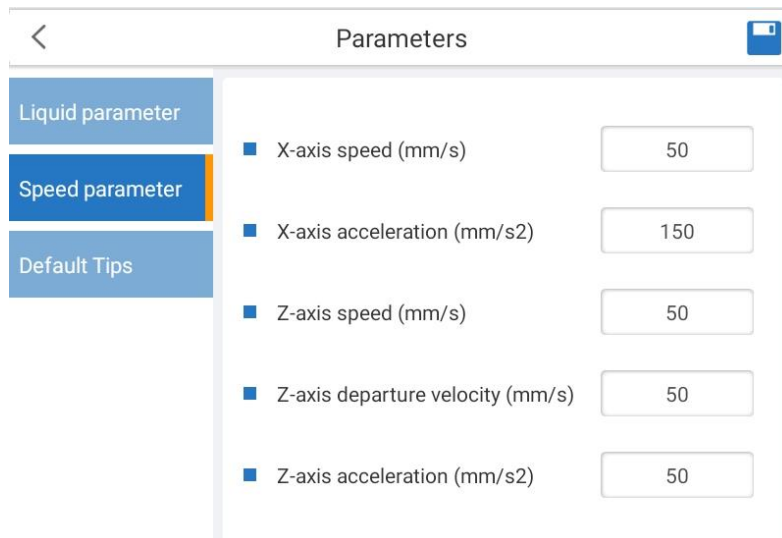


Different liquids require different pipetting parameters for accurate aspiration and dispensing. The liquid parameter management interface allows adding or removing different liquids from the selection list, and adjusting parameters for the different liquids. Liquid parameters can also be imported from or exported to a USB drive.



**Fig 33 Liquid Parameter Management Interface**

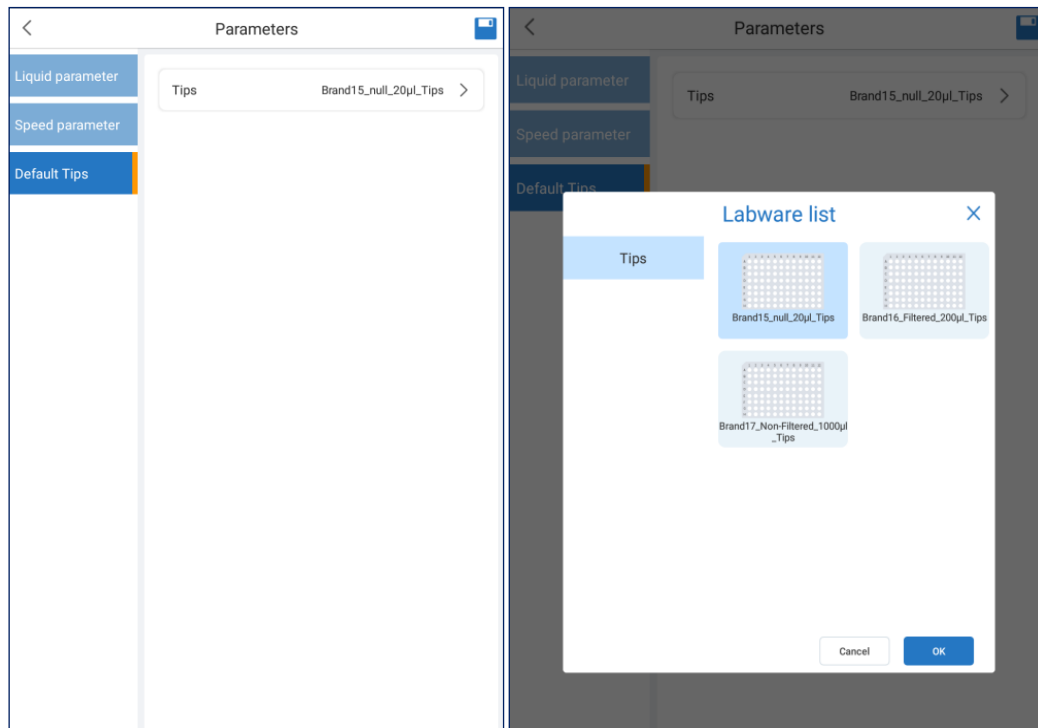
**Speed Parameter Settings:**



**Fig 34 Speed Parameter**

The speed parameter interface allows adjusting the speed and acceleration values of the X axis (motorized platform) and Z axis (pipetting head).

## Default Tips' Settings:



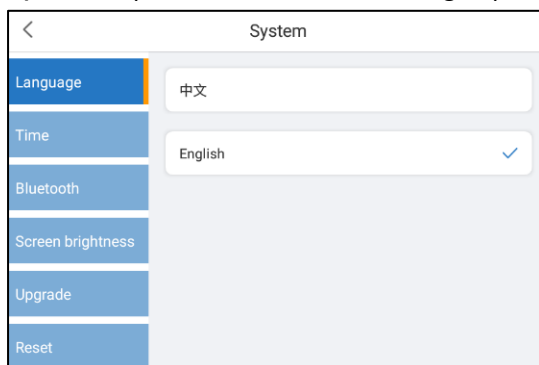
**Fig 35 Default Tips Interface**

Default tips interface can set default for tips.

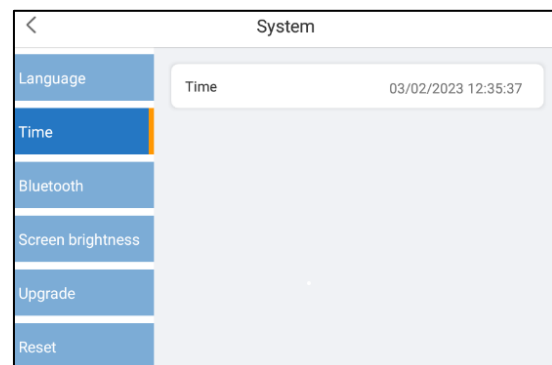
## System Settings

System settings are for selecting Language, Time, Screen brightness, Firmware Upgrades and Bluetooth options .

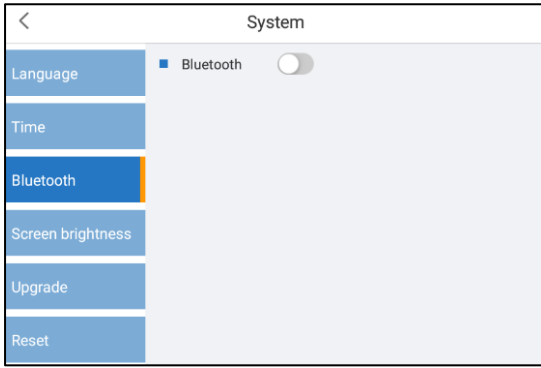
For firmware upgrades, insert a USB drive with updated firmware files to perform updates ( Fig 0.)



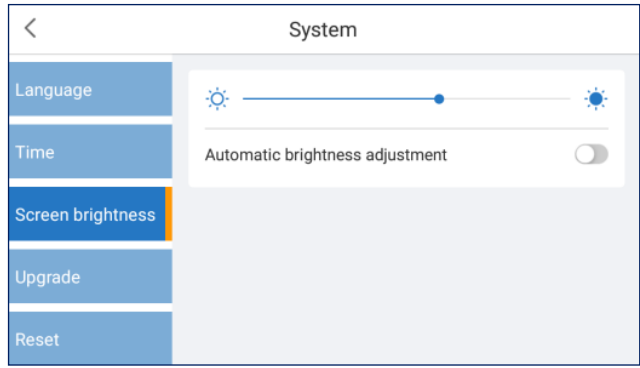
**Fig 36 System settings interface**



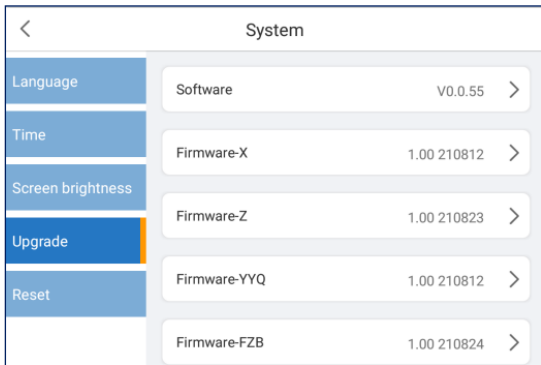
**Fig 37 Time settings**



**Fig 38 Bluetooth Settings**



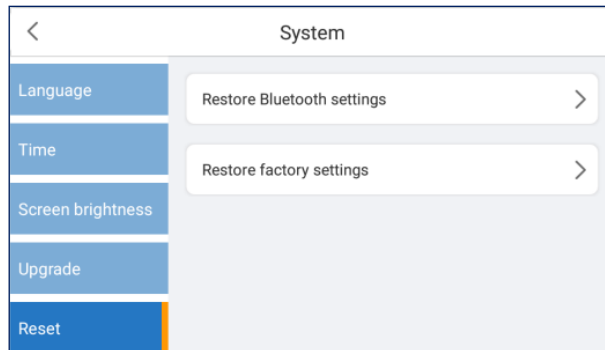
**Fig 39 Screen brightness settings**



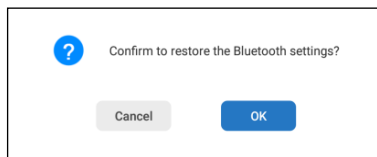
**Figure 40 System Upgrade Settings**



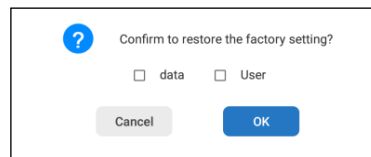
**Fig 41 Upgrade settings**



**Fig 42 Reset settings**

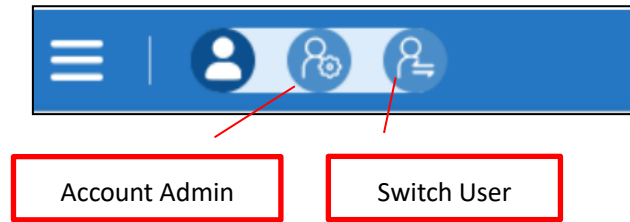


**Fig 43 Bluetooth settings**



**Fig 44 Restore the factory setting**

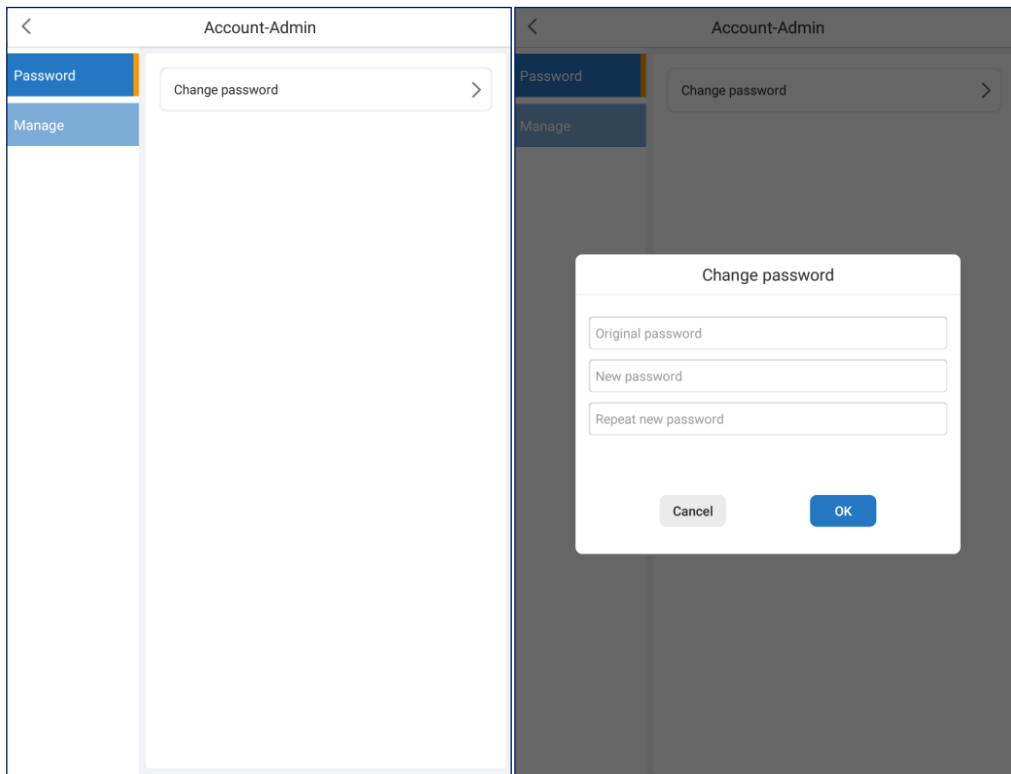
## User Settings



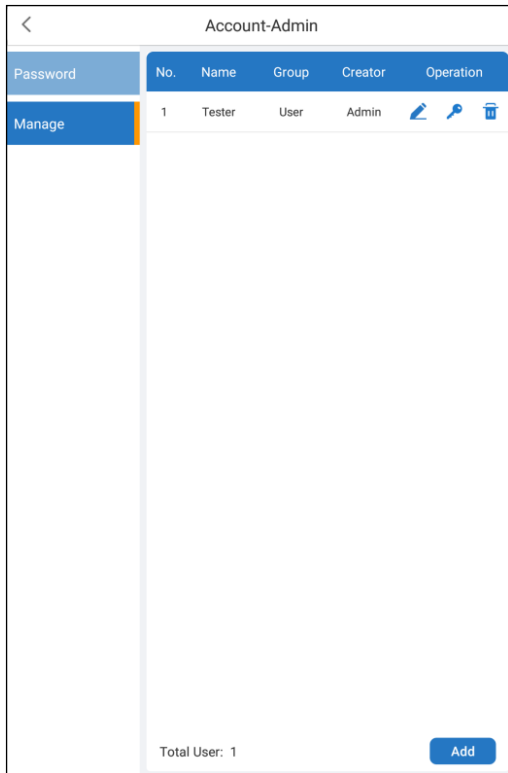
**Fig 53 User settings interface**

Clicking on the user name in the upper left corner to see user options, including Account Administration and Switch User, as shown in the image above.

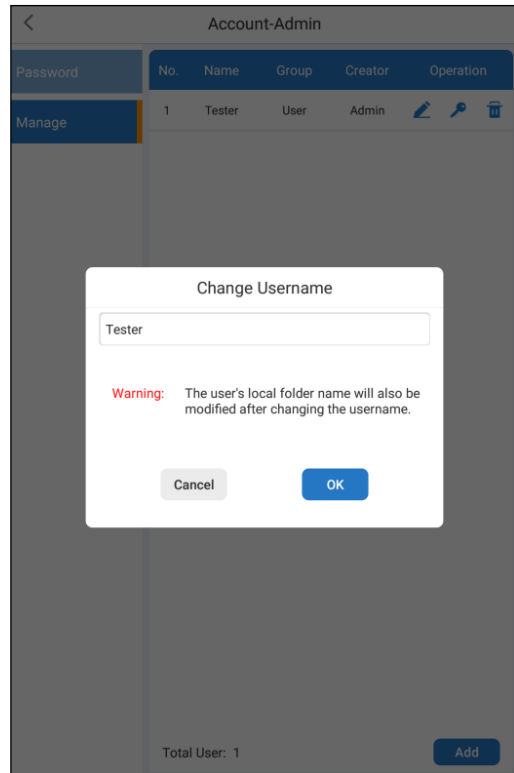
Per Fig , the Account Admin icon to enter user settings interface. Click "Password" to change the Admin password and click "Manage" to add or remove user accounts.



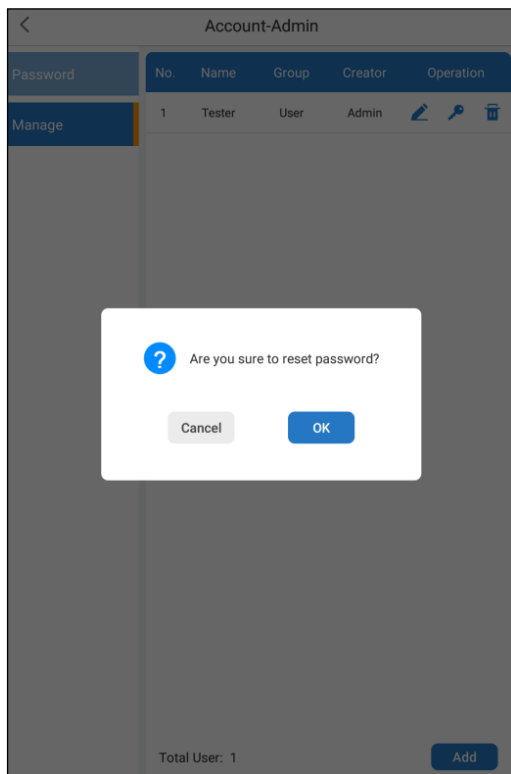
**Fig 54 Change password interface**



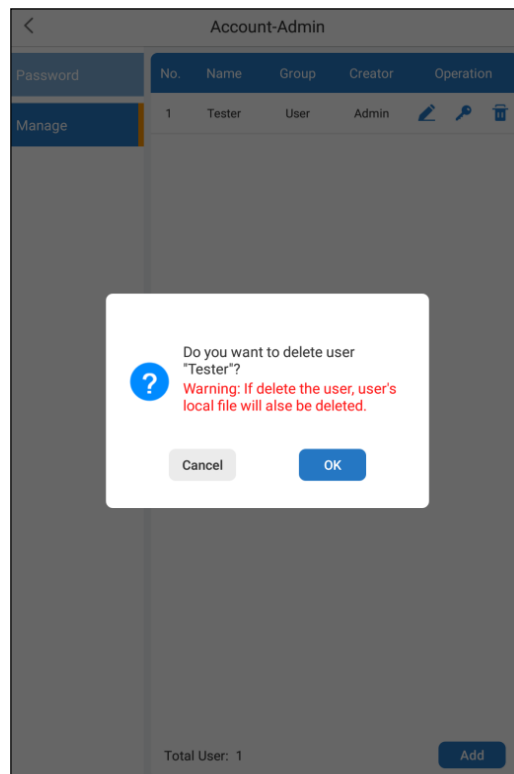
**Fig 55 User manage interface**



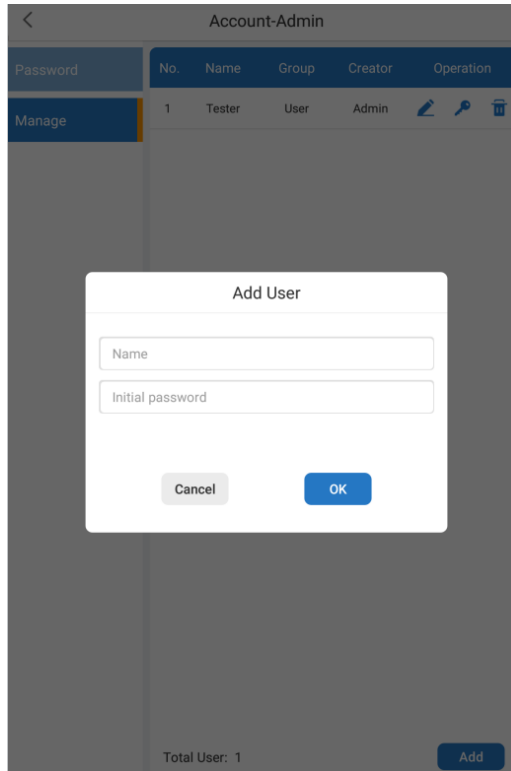
**Fig 56 Change username interface**



**Fig 57 Reset password Interface**






**Fig 58 Delete interface**



**Fig 59 Add user interface**

**Table 2 Function**

	Click to change the current user name (maximum of 16 characters can be used); See Fig
	Click to change the password for the user (maximum of 10 characters, including digits and case-sensitive letters) See Fig
	Click, to delete a user. After deleting a user, all data of the user will be deleted; See Interface <b>Fig</b>
Add	Add a new user name; See Fig

## Change User Account

Per Fig , click the “Switch user” icon to switch to a different user account.

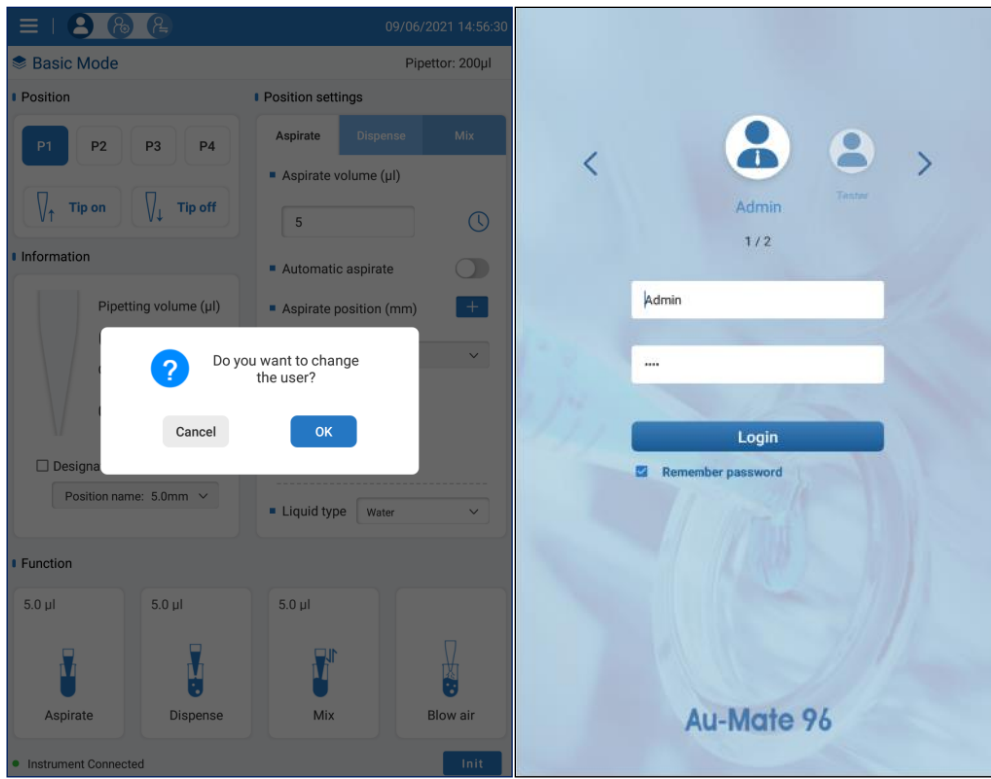


Fig 60 Change interface

## 8. Labware Management

From the main settings menu, click “Labware”, to enter labware management interface, as shown figure below.

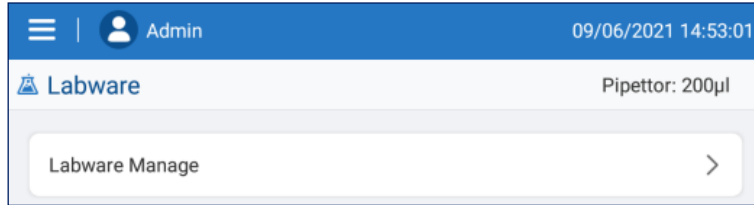


Figure 47 Labware Management

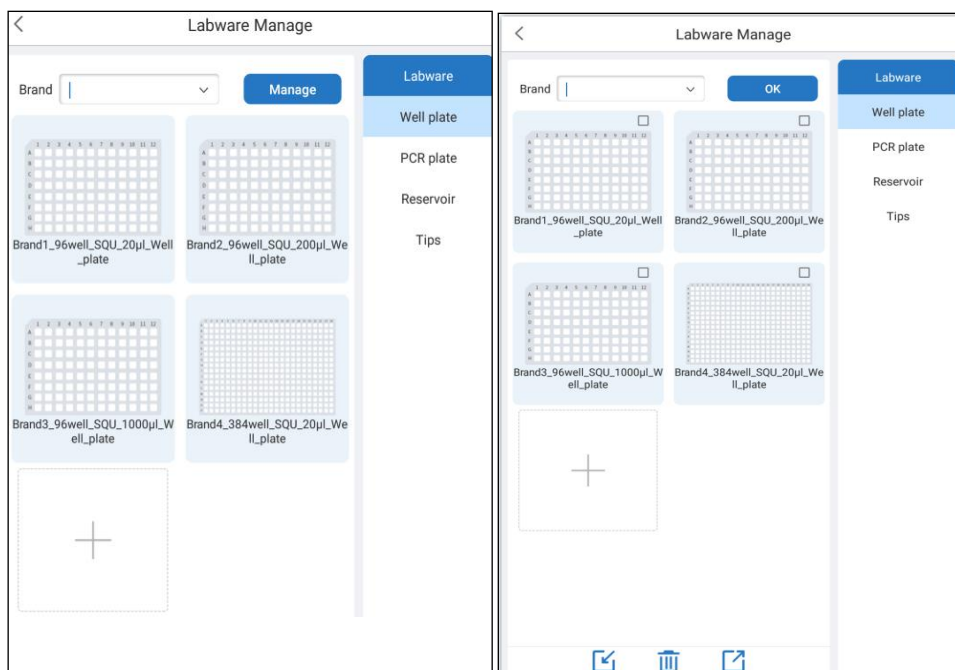


Fig 48 Labware management interface

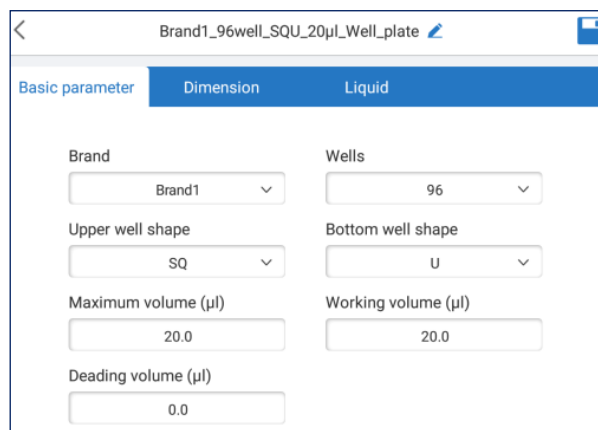
The 'New well plate' dialog box contains the following fields:

- Brand: A dropdown menu.
- Name: A text input field with 'Default' entered.
- Wells: A dropdown menu with '96' selected.
- Upper well shape: A dropdown menu with 'RD' selected.
- Bottom well shape: A dropdown menu with 'U' selected.
- Maximum volume: A text input field with '2200.0' and a 'µl' unit.
- Working volume: A text input field with '1000.0' and a 'µl' unit.
- Dead volume: A text input field with '10.0' and a 'µl' unit.

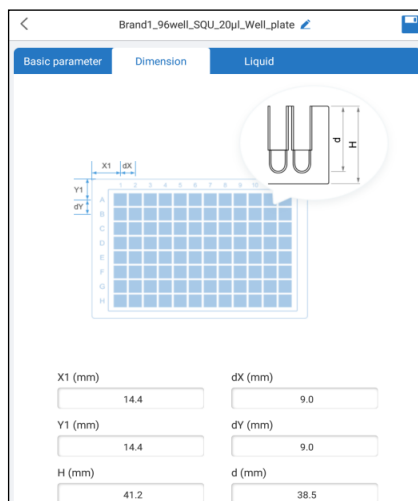
At the bottom are 'Cancel' and 'OK' buttons.

Fig 49 Labware new well plate interface

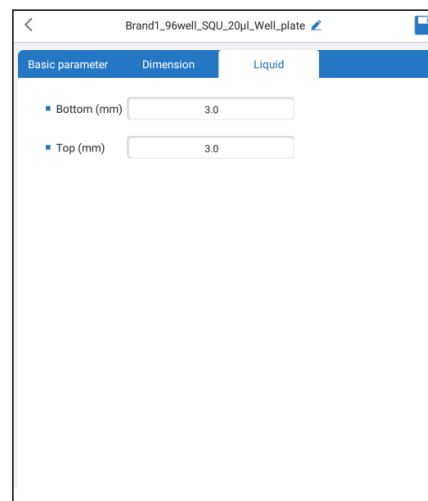
To add a new consumable that can be selected during programming, choose the type of consumable listed under "Labware", then click the "new" box which is the box with the "+" in the center (see Fig ); A brand can be selected or a new brand can be added. After entering a new brand and saving the newly created consumable, the new brand will be automatically saved as an option for future selection (see Fig ); Click the "Manage" button to delete a consumable. Or to import from or export to a USB drive. (see Fig ); Basic parameters such as well shape, well volume, dimensions, and liquid levels, can be adjusted (see Fig , Fig 0). The bottom and top of the liquid interface respectively represent the distance between the tips and the bottom when aspirating, the distance between the tips and top when dispensing.



**Fig 50 Basic parameter interface**



**Fig 51 Dimension interface**



**Fig 52 Liquid interface**

# Chapter 6 Maintenance

## 1. Suggested Maintenance Tools

The following tools are suggested for routine maintenance work:

A set of 1.5-6mm hex (Allen) keys , Phillips head screwdriver (large, medium, small), small tweezers, clean gauze, clean cotton swabs, clean brush, rubber gloves, 75% alcohol and cleaning fluid, etc.

## 2. Daily Maintenance

Daily maintenance is recommended after daily use. The specific operation steps are as follows:

- a. After daily use is completed, power off the instrument and remove the samples, reagents and consumables from the platform.
- b. Properly dispose of any used pipette tips and waste liquids, according to laboratory regulations or local regulations.
- c. Keep the platform clean. There should be no residual liquids or stains on the platform or in the rectangular indentations. If there is liquid residue, use paper towels to absorb any liquids, and then wipe and clean the platform with a clean soft cloth. Use 75% alcohol on a clean soft cloth to wipe and disinfect the platform and any other surfaces that require cleaning.
- d. When the instrument is not in operation for a long period, unplug it, and cover it with dust cover.

## 3. Regular Maintenance

In addition to daily maintenance, regular maintenance is required after the instrument has been operating for 6 months or has been in storage for a long period.

- a. Run a typical program without any consumables installed to check that the motors and tracks (X and Z axis) are operating smoothly. Check that the platform the guide rail is well lubricated and there is no dust and impurities on the guide rail. If found, please clean it up in time.
- b. Check that all the moving parts are not making any abnormal noises and that all screws are tight. If any screws have become loose, please tighten them.

## 4. Annual Maintenance


Contact the Accuris Instruments, or your authorized distributor or authorized service provider, for any necessary maintenance, including but not limited to the following items:

- a. Check that the moving platform is level and operating smoothly.
- b. Check the pistons and seals to make sure there is no leakage, and that pipetting volumes are consistent between channels.
- c. Calibrate the instrument as required to make sure it meets specifications.

## 5. Pipetting Head Replacement & Calibration

In the Settings mode, select “Maintenance” to enter the maintenance interface.

Base calibration and Pipettor calibration adjustments should be performed by authorized service personnel. Contact Accuris Technical Services or a local distributor for more information.

To switch a pipetting head, click Pipettor calibration and click the button “Replace module”. Follow the flow chart for pipettor head replacement in Section 2. Click the icon  to scan the QR code label on the pipetting module using the rear camera of the tablet. This automatically loads the specific calibration data for the pipetting module.

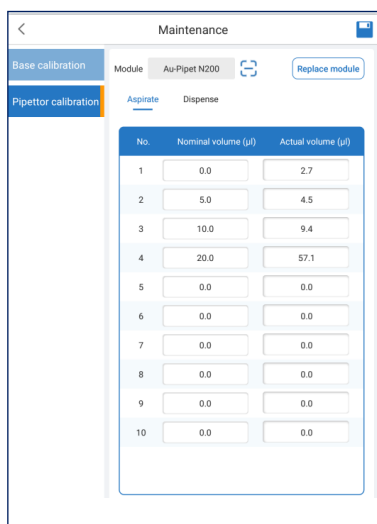


Fig 45 Pipettor calibration

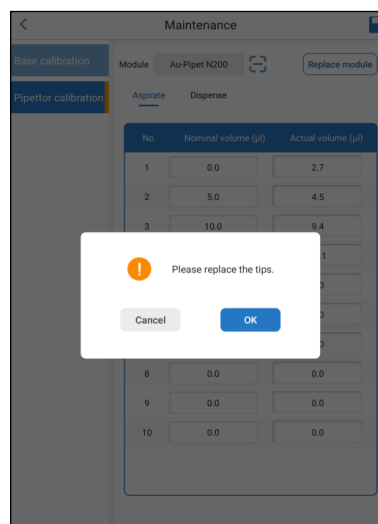


Fig 46 Prompt box for pipette head replacement

## Chapter 7 Troubleshooting

No.	Symptom	Causes Analysis	Solution
1.	Tablet not connecting to Instrument	Power cord not connected	Check power
		Power Switch failure	Replace switch
		Fuse blown	Replace fuse
		Other	Contact distributor or Accuris Service Dept.
2.	Instrument does not operate	Controller failure	Contact distributor or Accuris Service Dept.
		Motor failure	Contact distributor or Accuris Service Dept.
3.	Abnormal sound during operation	Guide rail problem	Contact distributor or Accuris Service Dept.
		Motor failure	
4. 5.	Abnormal sound during operation	Gears or screw drive is worn or damaged	Contact distributor or Accuris Service Dept.
	SWITCH button not working	Button failure	Contact distributor or Accuris Service Dept.
	Pipetting is not accurate	Calibration required	Contact distributor or Accuris Service Dept.
6.	The pipetting head not positioning correctly during operation	Calibration parameters missing	Restore factory Settings/ Contact distributor or Accuris Service Dept.

<b>Failure module</b>	<b>Failure name</b>	<b>Error</b>
X-axis	Over temperature pre-warning.	<b>E109</b>
	Over temperature.	<b>E119</b>
	Short circuit in motor.	<b>E107</b>
	Failed to leave zero.	<b>E413</b>
	Failed to move to destination.	<b>E114</b>
	Failed to return zero.	<b>E403</b>
	Memory is damaged.	<b>E713</b>
	Motor data is lost.	<b>E723</b>
	Motor data error.	<b>E733</b>
	Calibration data is lost.	<b>E743</b>
	Calibration data error.	<b>E753</b>
	Steps lost.	<b>E134</b>
Z-axis	Failed to leave zero.	<b>E413</b>
	Failed to return zero.	<b>E403</b>
	Memory is damaged.	<b>E713</b>
	Motor data is lost.	<b>E723</b>
	Motor data error.	<b>E733</b>
	Calibration data is lost.	<b>E743</b>
	Calibration data error.	<b>E753</b>
Movement module	Over temperature pre-warning.	<b>E109</b>
	Over temperature.	<b>E119</b>
	Short circuit in motor.	<b>E107</b>
	Memory is damaged.	<b>E713</b>
	Motor data is lost.	<b>E723</b>
	Motor data error.	<b>E733</b>
	Calibration data is lost.	<b>E743</b>
	Calibration data error.	<b>E753</b>
Auxiliary plate	Memory is damaged.	<b>E703</b>