



**ULTRA LOW TEMPERATURE | BENCHTOP / UNDERCOUNTER FREEZER**  
 Designed for rigorous environments needing precise temperature regulation, this exceptionally reliable compact ULT freezer ensures your critical materials are stored securely and effectively.

### ▶ RELIABLE FREEZING

ARCTIKO's unique single compressor technology guarantees superior temperature uniformity and exceptional cooling performance, allowing you to concentrate on your research without worry. This compact ultra-low temperature (ULT) freezer not only facilitates easy access to samples but also offers flexible placement options in the workplace.

### ▶ GLOBAL COMPATIBILITY

The primary cable of this device is interchangeable, allowing it to be used globally. Switch between Schuko, NEMA, and UK plugs with ease. Additionally, there's no need for a transformer; the product is compatible with any voltage from 110V to 240V. It automatically adjusts its operation based on the voltage input.

### ▶ NATURAL REFRIGERANT

This device delivers exceptional cooling performance and is eco-friendly, boasting an ultra-low Global Warming Potential (GWP) of just 4. This excellent rating is achieved through the use of natural refrigerants, underscoring its minimal impact on global warming.

### ▶ PROBE & ACCESS PORTS

As standard, the unit is equipped with two temperature probes inside the chamber. One probe monitors the air temperature in the chamber and controls the operation of the compressors, while the other probe monitors the temperature of the stored elements, simulated through the aluminum block.

### ▶ SINGLE COMPRESSOR TECHNOLOGY

ARCTIKO's single compressor system features a filterless design, which prevents malfunctions due to dust accumulation in filters. This reduces maintenance requirements for the cooling system and ensures more stable operation.

### ▶ VACUUM VALVE AND KEY LOCK

The unit enhances security and stabilizes internal conditions with a vacuum valve and a key lock on the door. The vacuum valve efficiently equalizes pressure inside the unit, allowing for immediate access without lengthy delays.



**NATURAL REFRIGERANT  
 LOWEST GWP**

ULUF P50 MV



**SINGLE COMPRESSOR SYSTEM**



**VACUUM INSULATED PANELS**



**AIRFLOW CONTROL**



**FILTERLESS CONSTRUCTION**



**NATURAL REFRIGERANT**



Heated door frame prevents ice build up around the gasket.



This unit includes a well-utilized inner compartment with room for up to 500 samples.



Direct cooling for optimized temperature stability and uniformity, even with multiple door openings.



The ARCTIKO OneGrip™ handle is designed and developed for easy and ergonomic use.

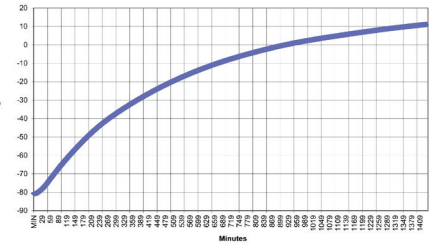
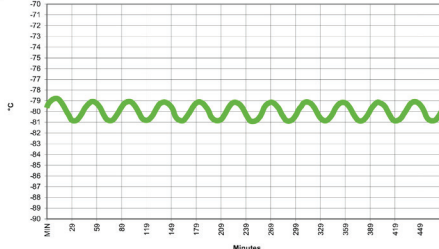
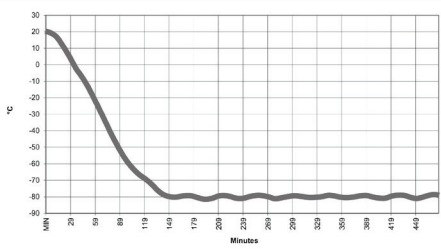

### ► IMPROVED RECOVERY TIMES

Pull-down times measures the time taken for temperature to rise, the faster the better. Hold over indication the freezers ability to keep the samples safe.

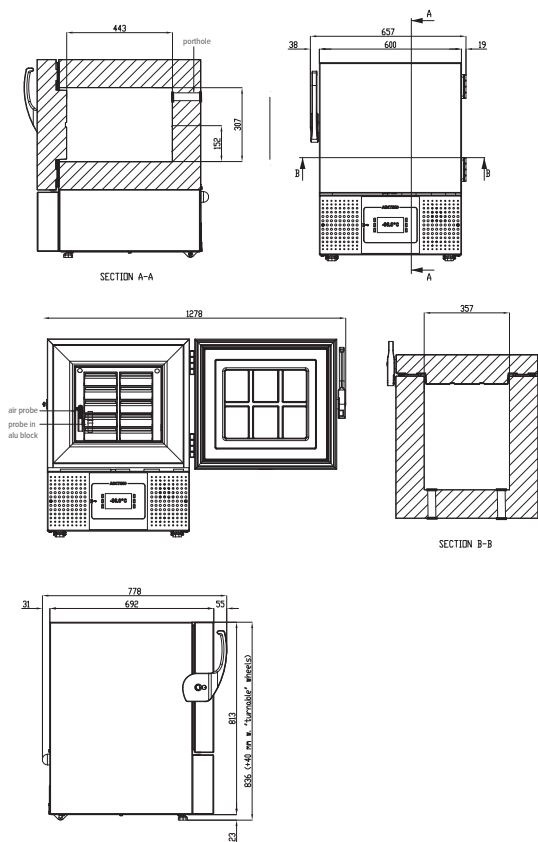

The ARCTIKO Integraline ULUF P50 MV Model supports following optional features:

- Modbus adapter for V500 controller
- Temperature chart recorder (external mounting)
- GSM alarm module
- Racks & boxes
- Cryo gloves

MODEL		ULUF P50 MV
Main specifications	Item code	1000002-01
	Temperature range (°C)	-25 / -86
	Max. ambient temperature (°C)	32
	Capacity (L)	50
	Exterior dimensions WxDxH (mm)	657x778x836
	Interior dimensions WxDxH (mm)	357x443x307
	Weight (KG)	82
	Insulation (mm)	120
	Cooling technology	Single system / Static Inverter / MV
	Controller model / probe type	V500 / PT100
Power	Power supply (V)	110 - 230
	Frequency (Hz)	50/60
	Power consumption (kWh/24h)	3.48
	AMP (A)	3,0 (110V) / 1,5A (230V)
	Power (Watt)	280
	Horsepower (HP)	3/4
Alarm functions	Alarm (displayed as text, not codes)	Yes
	Visual / acoustic alarm	Yes / Yes
	Power failure alarm	Yes
	Adjustable high / low-temperature alarm	Yes / Yes
	Open door alarm	Yes
	Probe failure alarm	Yes
	Low battery alarm	Yes
Data logging & external connection	Compressor failure alarm	Yes
	Battery backup for alarms (approx. hrs.)	72
	Voltage-free contact for remote alarm (e.g. GSM alarm module)	Yes
	Electronic data logger	Yes
	RS 485 port	Optional
Display features	USB port for software update & data download	Yes
	Temperature chart recorder	Optional (external mounting)
	Display type	5" touch screen
	Number of optional reference probes	2
Other features	Password protection for turning unit on / off	Optional
	Temperature graph on display	Yes
	Automatic defrost	No
	Antifreeze function	No
	Vacuum release port	Yes
	Access port for external probe etc. (int. diameter mm)	20
	Light	No
	Lock with key	Yes
	Castors (total pcs) / castors with brake (pcs)	2 / 0
	Fixed feet (pcs) / levelling feet (pcs)	0 / 2
	Sub lids / inner doors (pcs)	No
Refrigeration & cabinet	Reversible door(s)	No
	Total capacity of 50 mm boxes 9x9 dividers (pcs)	36
	Total capacity of 75 mm boxes 9x9 dividers (pcs)	24
	Total capacity of 96 mm boxes 9x9 dividers (pcs)	18
	Number of compressors	1
	Refrigerant	Nature R2
	Interior cabinet material	Stainless steel
Exterior cabinet material	Painted Steel	
Colour (exterior cabinet)	White	
Foam type	Polyurethane	
Shipping	VIP vacuum insulated panels	Yes
	Shipping weight (kg)	109
	Shipping dimensions WxDxH (cm)	83x75x103
	Shipping volume (m <sup>3</sup> )	0,64



IEC 61010 / EN IEC 61010 / UL 61010 / CSA C22.2 no 61010