



REACH-IN REFRIGERATORS AND FREEZERS

User Manual

Models:

Solid Door Refrigerators

ARS23ML
MLR23S
SCRR232

ARS49ML
MLR49S
SCRR492

Glass Door Refrigerators

ARG23ML
MLR23G
SCR23SSG

ARG49ML
MLR49G
SCR49SSG

Solid Door Freezers

AFS23ML
MLF23S
SCFF237

AFS49ML
MLF49S
SCFF497

BEFORE USE, PLEASE READ AND FOLLOW ALL SAFETY RULES AND OPERATING INSTRUCTIONS.

Write Model and Serial Numbers here:
Model # _____
Serial # _____

TABLE OF CONTENTS

<i>Important Safeguards</i>	3-4
<i>Installation</i>	5
<i>Maintenance and Cleaning</i>	5-6
<i>Alarm Function for Cleaning Condenser</i>	6
<i>Operating</i>	6-9
<i>Basic Operation</i>	6
<i>Electronic Controller</i>	7-9
<i>Troubleshooting</i>	10
<i>Specifications</i>	11-13
<i>Temporary Set Points and Ranges</i>	13
<i>Limited Warranty</i>	14
<i>French Version of this User Manual</i>	15-28

IMPORTANT SAFEGUARDS



Before the appliance is used, it must be properly positioned and installed as described in this manual, so read the manual carefully. To reduce the risk of fire, electrical shock or injury when using the appliance, follow basic precautions, including the following:

DANGER

- Plug into a grounded 3-prong outlet, do not remove grounding prong, do not use an adapter, and do not use an extension cord.
- Do not connect grounding wire to a gas or water pipe.
- Replace all panels before operating.
- It is recommended that a separate circuit serving only your appliance be provided. Use receptacles that cannot be turned off by a switch or pull chain.
- Never clean appliance parts with flammable fluids. These fumes can create a fire hazard or explosion. And do not store or use gasoline or other flammable vapors and liquids in the vicinity of this or any other appliance. The fumes can create a fire hazard or explosion.
- Before proceeding with cleaning and maintenance operations, make sure the power line of the unit is disconnected.
- Do not connect or disconnect the electric plug when your hands are wet.
- Unplug the appliance or disconnect power before cleaning or servicing. Failure to do so can result in electrical shock or death.
- Do not attempt to repair or replace any part of your appliance unless it is specifically recommended in this manual. All other servicing should be referred to a qualified technician.
- This appliance is CFC- and HFC-free and contains a small quantity of liquid propane (R290a) which is environmentally friendly, but flammable. It does not damage the ozone layer, nor does it increase the greenhouse effect. Care must be taken during transportation and setting up of the appliance that no parts of the cooling system are damaged. Leaking coolant can ignite and may damage the eyes. In the event of any damage:
 - Avoid open flames and anything that creates a spark,
 - Disconnect from the electrical power line,
 - Air the room in which the appliance is located for several minutes and
 - Contact the Service Department for advice.
- The more coolant there is in an appliance, the larger the room it should be installed in. In the event of a leakage, if the appliance is in a small room, there is the danger of combustible gases building up. The amount of coolant in the appliance is stated on the data plate on the appliance. It is hazardous for anyone other than an Authorized Service Person to carry out servicing or repairs to this appliance.
- Take serious care when handling, moving, and using the appliance to avoid either damaging the refrigerant tubing or increasing the risk of a leak.
- Replacing component parts and servicing shall be done by factory authorized service personnel so as to minimize the risk of possible ignition due to incorrect parts or improper service.

CALIFORNIA CARB/SNAP DISCLOSURE

This product uses eco-friendly hydrocarbon refrigerant and fully complies with California CARB regulations.

However, we are required by California Law to provide the following disclosure statement in every product sold in California.

"This equipment is prohibited from use in California with any refrigerants on the 'List of Prohibited Substances' for that specific end-use, in accordance with California Code of Regulations, title 17, section 95374. This disclosure statement has been reviewed and approved by Felix Storch, Inc. and Felix Storch, Inc. attests, under penalty of perjury, that these statements are true and accurate."

This product does **not** use any refrigerants on the 'List of Prohibited Substances'"

DANGER - Risk of fire or explosion. Flammable refrigerant used.

- Do not use mechanical devices to defrost refrigerator. Do not puncture refrigerant tubing.
- To be repaired only by trained service personnel. Do not puncture refrigerant tubing.

CAUTION - Risk of fire or explosion

- Flammable refrigerant used. Consult repair manual/owner's guide before attempting to service this product. All safety precautions must be followed.
- Dispose of properly in accordance with federal or local regulations. Flammable refrigerant used.
- Risk of fire or explosion due to puncture of refrigerant tubing. Follow handling instructions carefully. Flammable refrigerant used.

CAUTION - Avoid obstructing any ventilation openings in the appliance or in the enclosure when building-in.

 **WARNING**

FOLLOW WARNING CALLOUTS BELOW ONLY WHEN APPLICABLE TO YOUR MODEL

- Use two or more people to move and install the appliance. Failure to do so can result in back or other injury.
- To prevent overheating and fire hazard, remove all packaging before use, including the tray at the bottom of the appliance.
- When installing, leave at least 8" at the back of the unit.
- To ensure proper ventilation for your appliance, the front of the unit must be completely unobstructed. Choose a well-ventilated area with temperatures above 60°F (16°C) and below 90°F (32°C). This unit must be installed in an area protected from the elements, such as wind, rain, water spray or drips.
- The appliance should not be located next to ovens, grills or other sources of high heat.
- The appliance must be installed with all electrical, water and drain connections in accordance with state and local codes. A standard electrical supply (115 V AC only, 60 Hz), properly grounded in accordance with the National Electrical Code and local codes and ordinances, is required.
- Do not kink or pinch the power supply cord of the appliance.
- The size of the fuse (or circuit breaker) should be 15 amperes.
- It is important that the appliance be leveled in order to work properly. You may need to make several adjustments to level it.
- All installations must be in accordance with local plumbing code requirements.
- Make certain that the pipes are not pinched, kinked or damaged during installation.
- Check for leaks after connection.
- Never allow children to operate, play with or crawl inside the appliance.
- Do not use solvent-based cleaning agents or abrasives on the interior. These cleaners may damage or discolor the interior.
- Use this appliance only for its intended purpose as described in this *User's Manual*.
- Keep fingers out of the "pinch point" areas. Clearances between the doors and between the doors and cabinet are necessarily small. Be careful closing doors when children are in the area.

 **DANGER** 

Risk of child entrapment!

Child entrapment and suffocation are not problems of the past. Junked or abandoned appliances are still dangerous, even if they will "just sit in the garage a few days".

Before discarding your old refrigerator:

- *Take off the doors.*
- *Leave the shelves in place so that children may not easily climb inside.*

- SAVE THESE INSTRUCTIONS -

INSTALLATION

- This unit is intended for indoor use only.
- Electrical Connection
 - The unit should be plugged into a 115V±10% 60Hz, grounded wall receptacle.
 - Do not plug other electrical units into the same wall receptacle as this unit.
 - Do not use an extension cord.
 - Compressor warranties are void if the compressor burns out due to low voltage.
- Check points for selecting location
 - The minimum clearance between the back of the cabinet and wall should be at least 7 inches.
 - Keep the unit away from sunlight and other heat generating equipment.
 - The unit should be properly leveled to provide adequate drainage.
- Installing casters
 - Install casters in the weld nut in the bottom of the unit.
 - Make sure that casters with brakes are installed in front.
- Install shelves using shelf clips provided in the accessory pack.

CAUTION: This unit uses flammable refrigerant. Use care when handling and operating to avoid damaging the refrigerant tubing or increasing the risk of a leak.

MAINTENANCE AND CLEANING

NOTE: All service should be performed by factory-authorized personnel. All component parts will be replaced with like components to minimize the risk of possible ignition due to incorrect parts or improper service.

- The interior surface of the cabinet should be periodically cleaned with a solution of warm water and baking soda. This solution will help to remove any odors from spillage that has occurred. The exterior of the cabinet should also be cleaned frequently with a stainless steel cleaner, glass cleaner or mild soap solution. Do not use chlorinated cleaners on the stainless steel surface.
- The drain pan next to the condensing unit should be checked once every 2 weeks and emptied when necessary.
- The door gaskets should be periodically cleaned with a mild soap solution to extend their life.
- The shelving can be cleaned in a sink with a mild soap solution and soft bristled brush.

Condenser Coil

- Before cleaning the condenser coil, unplug the unit. Periodically cleaning the condenser coil will help the heat exchange of the refrigeration system and increase the efficiency. Remove the bottom grill from the cabinet to clean the condenser coil. It is located behind the grill. Use a soft bristled brush to remove any dirt particles that are on the fins of the condenser coil. After this, use a vacuum cleaner or compressed air to remove the loosened particles. Replace the bottom grill and plug in the unit to outlet. Failure to clean the condenser coil can lead to performance loss and compressor failure.
- Wait at least 5 minutes after unplugging the unit before plugging it in again.
- The pressure relief filter is in the filter bracket which is located in the top of AFS, ARS and ARG models. The filter should be checked monthly and cleaned with a soft brush when necessary. If the filter is clogged, it would take more time to open the door again.

Alarm Function for Cleaning Condenser

This function reminds the customer that the condenser cleaning time is every 6 months. Dust piled up on the condenser pin can cause poor refrigeration function and compressor overload or failure. Be sure to clean it periodically.

- Cleaning Reminder:
When the buzzer sounds continuously for 1 hour, [CL] will blink on the display.
- Releasing Alarm:
 1. Press **Mode** and **Verify** buttons together for 5 seconds.
 2. The buzzer stops and [CL] disappears.
 3. The current temperature will appear on the display.
- If no action is taken: (e.g., during absence):
 - Buzzer: Stops automatically after 1 hour of continuous alarm sound
 - Display: [CL] continues blinking until the alarm is manually released.

OPERATION

Basic Operation

- When the unit is plugged in and the power switch is turned on, the display panel will light for 2 seconds followed by a beeping sound. The current cabinet temperature will be displayed.
- If the cabinet temperature is **higher than -5°C** (freezer models), or **14°C** (refrigerator models), the panel displays [**Hi**].
- If the cabinet temperature is **lower than -40°C** (freezer models), or **-2°C** (refrigerator models), the panel displays [**Lo**].
- The power switch is located in the right side of top grille.
- Compressor operation and defrost function are controlled by the electronic controller.
- The cabinet light turns on when the door is opened.
- For glass-door models, the light switch is located next to the power switch in the right side of the top grille.

Open Door Alarm

1. When the door remains open, a [door open] warning will sound.
 - If the door remains open for more than **30 seconds**, the alarm beeps **3 times**.
 - If the door remains open for more than **60 seconds**, the alarm beeps **5 times**.
 - If the door remains open for more than **5 minutes**, the alarm will sound **continuously** until the door is closed.

NOTE: The P-sensor for the High or Low Temperature Alarm may sound at installation depending on the the cabinet temperature. To stop the alarm, press the **Mode** and **Verify** buttons together for 2 seconds. This will continue until the temperature stabilizes between Hi and Low temperature range.

Electronic Controller
Display Channel

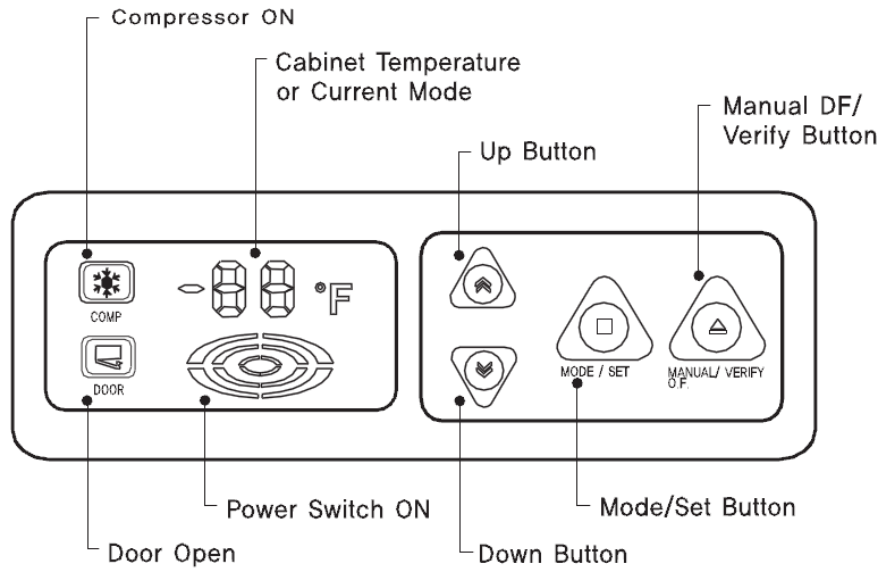

Electronic Controller Setting Mode

Display	Description
St	Temperature Setting Mode
di	Temperature Differential Setting Mode
th	Cabinet Temperature Verification Mode
dt	Defrost Frequency Setting Mode
tb	Rapid Freeze Mode (Freezers Only)
dF	Forced Defrost Mode
SE	Temperature Unit Converter mode (°F ↔ °C)
Hi	P sensor High temperature alarm setting mode
Lo	P sensor Low temperature alarm setting mode
HL	P sensor MAX temperature MIN temperature verification mode

Control Mode

Set Cabinet Temperature

1. Press **[MODE / SET]** and **[DOWN]** until **[St]** is displayed.
2. Press **[MODE / SET]** to see current temperature set point.
3. To change the set point, press **[UP]** or **[DOWN]** until the desired temperature is displayed.
4. At the end of the sequence, press **[MODE / SET]** to set the temperature.
5. To display the cabinet temperature again, press **[UP]** or **[DOWN]** until **[th]** is displayed and then press **[VERIFY]**.
The temperature set point is the value for the average cabinet. The temperature is adjustable within certain ranges. (See chart on page 13 for default temperature set points.)

Set Temperature Differential – (For Service Technician Only!)

1. Press **[MODE / SET]** and **[DOWN]** until **[di]** is displayed.
2. Press **[MODE / SET]** to see current temperature differential.
3. To change the set point, press **[UP]** or **[DOWN]** until the desired value is displayed.
4. At the end of the sequence, press **[MODE / SET]** to set the value.
5. To display the cabinet temperature again, press **[UP]** or **[DOWN]** until **[th]** is displayed and then press **[VERIFY]**.
 - The default temperature differential set point is 4°C and the valid setting range is (2°C - 10°C).
 - Compressor ON/OFF: Temperature set point ± (temperature differential/2)

Verify Cabinet Temperature

1. Press **[MODE / SET]** and **[DOWN]** until **[th]** is displayed.
2. Press **[MODE / SET]**, and you will see current T-sensor temperature after **[t-]** is displayed, current D-sensor temperature after **[d-]** is displayed, and current P-sensor temperature after **[P-]** is displayed. These values will be shown for each 1 second in sequence.
3. Press **[VERIFY]** to return to display cabinet temperature.

Run Turbo Freeze

1. Press **[MODE / SET]** and **[DOWN]** until **[tb]** is displayed.
2. Press and hold **[MODE / SET]** for 2 seconds to start turbo freeze.

Once the Turbo Freeze mode is chosen, the compressor will start running continuously for 2 hours.

Stop Turbo Freeze

1. During turbo freeze, press **[MODE / SET]** for 2 seconds to stop turbo freeze.
2. The **[tb]** will flash 5 times and then return to normal display mode.

Set Defrost Frequency

1. Press **[MODE / SET]** and **[DOWN]** until **[dt]** is displayed
2. Press **[MODE / SET]** to see current defrost frequency.
3. To change the defrost frequency, press **[UP]** or **[DOWN]** until the desired value is displayed.
4. At the end of the sequence, press **[MODE / SET]** to set the value.
5. To display the cabinet temperature again, press **[UP]** or **[DOWN]** until **[th]** is displayed and then press **[VERIFY]**.
 - The unit is preset at the factory to defrost every 12 hours. (2 defrosts per day).
 - The defrost frequency can be changed from 4 hours to 12 hours with a two hour interval.
 - During defrosting, **[dF]** is displayed instead of the cabinet temperature.

Run Force Defrost – (For Service Technicians Only!)

1. Press **[MODE / SET]** and **[DOWN]** until **[dF]** is displayed.
2. Press and hold **[MANUAL DF]** for 2 seconds to start forced defrost.

How to Stop Force Defrost – (For Service Technicians Only!)

1. During forced defrost, press and hold **[MANUAL DF]** for 2 seconds to stop forced defrost.
2. The **[dF]** will flash 5 times and then return to normal display mode.

How to Change P-sensor High Alarm Setting

1. Press **[MODE / SET]** and **[DOWN]** until **[Hi]** is displayed.
2. Press **[MODE / SET]** to see current high temperature alarm setting.
3. To change the high temperature alarm setting, press **[UP]** or **[DOWN]** until the desired value is displayed, then press **[MODE / SET]** to set the value.

How to Change P-sensor Low Alarm Setting

1. Press **[MODE / SET]** and **[DOWN]** until **[Lo]** is displayed.
2. Press **[MODE / SET]** to see current low temperature alarm setting.
3. To change the low temperature alarm setting, press **[UP]** or **[DOWN]** until the desired value is displayed, then press **[MODE / SET]** to set the value.
 - See the valid setting ranges for freezers and refrigerators in the chart on page 13.

P-sensor High Temperature and Low Temperature Verification & Reset

1. Press **[MODE / SET]** and **[DOWN]** until **[HL]** is displayed.
2. Press **[VERIFY]**. Then you will see the Highest temperature value of P-Sensor after **[H-]** is displayed and the Lowest temperature value of P-Sensor after **[L-]** is displayed. The Highest and Lowest temperature values of P-Sensor will be shown in sequence.
3. To exit this mode, press **[VERIFY]**
4. To reset to default value, press and hold **[MODE / SET]** for 2 seconds.

Convert the Temperature Mode (F↔C)

1. Press **[MODE/SET]** and **[DOWN]** until **[SE]** is displayed.
2. Then press **[MODE/SET]** and you will be able to see the current temperature set mode with blinking sign either F or C.
3. To convert the temperature mode, press **[UP]** or **[DOWN]** until the desired mode is displayed.
4. Press **[MODE/SET]** to fix the temperature mode.
5. Press **[UP]** or **[DOWN]** until **[th]** is displayed
6. Press **[VERIFY]** to exit the mode.

TROUBLESHOOTING

Problem	Possible Cause	Remedy
Compressor will not start	Power connection failure	Check power cord and plug it in
	Power switch is in 'off' position	Move it to 'on' position
The unit does not refrigerate well	Temperature set point is too high	Correct temperature set point
	The door is opened too frequently	
	Loading of too much warm or moist product	
	Not enough ventilation	Move the unit to a well ventilated place with at least 180mm(7 inches) of clearance on all sides
	Condenser is clogged	Clean it
Condensation on cabinet exterior	High humidity air can result in condensation	Wipe with cloth

If you continue to experience issues, contact Accucold's technical support department at **1-888-4- MEDLAB** or visit our website <https://www.accucold.com/support>

SPECIFICATIONS

PRODUCT		Solid Full Door Freezers		Solid Full Door Refrigerators	
MODELS		AFS23ML MLF23S SCFF237	AFS49ML MLF49S SCFF497	ARS23ML MLR23S SCRR232	ARS49ML MLR49S SCRR492
Capacity		650 ℓ (23ft ³)	1,385 ℓ (49ft ³)	650 ℓ (23ft ³)	1,385 ℓ (49ft ³)
Exterior Dimensions (including Casters, Door handles)	(W)	695mm (27.4 ft ³)	1,400mm (55.2 ft ³)	695mm (27.4 ft ³)	1,400mm (55.2 ft ³)
	(D)	838mm (33 ft ³)			
	(H)	2,127mm (83.7 ft ³)			
Swing Doors		1	2	1	2
Shelves		4	8	4	8
Compressor		3/5HP	3/4HP	3/8HP	3/8HP
Power Voltage		115V / 60Hz			
Plug In-Installation		NEMA 5-15P		NEMA 5-15P	
Amps		8.0A	10.5A	7.5A	7.5A
Refrigerant		R-290			
		100g (3.5 oz)	130g (4.6oz)	70g (2.5oz)	90g (3.2 oz)
Product Weight		124kg (273 lb)	194kg (428 lb)	121kg (267lb)	186kg (410lb)

PRODUCT		Glass Door Refrigerators		
MODELS		ARG23ML MLR23G SCR23SSG	ARG49ML MLR49G SCR49SSG	
Capacity		650 l (23ft ³)	1,385 l (49ft ³)	
Exterior Dimensions (including Casters, Door handles)	(W)	695mm (27.4 ft ³)	1,400mm (55.2 ft ³)	
	(D)	838mm (33 ft ³)		
	(H)	2,127mm (83.7 ft ³)		
Swing Doors		1	2	
Shelves		4	8	
Compressor		3/8HP	3/8HP	
Power Voltage		115V / 60Hz		
Plug In-Installation		NEMA 5-15P		
Amps		7.5A	7.5A	
Refrigerant		R-290		
		70g (2.5oz)	90g (3.2 oz)	
Product Weight		126kg (278lb)	200kg (441lb)	

Temperature Set Points and Ranges

Model	Suggested Set Point	Temperature Range
FREEZERS		
AFS23ML, AFS49ML, MLF23S, MLF49S	-25°C	-30 to -15°C
SCFF237, SCFF497	-5°F	-10 to 25°F
SOLID DOOR REFRIGERATORS		
ARS23ML, ARS49ML, MLR23S, MLR49S	4°C	2 to 8°C
SCRR232, SCRR492	36°F	33 to 41°F
GLASS DOOR REFRIGERATORS		
ARG23ML, ARG49ML, MLR23G, MLR49G	4°C	2 to 8°C
SCR23SSG, SCR49SSG	36°F	33 to 41°F

LIMITED WARRANTY

TWO-YEAR LIMITED WARRANTY

Warranty coverage is available within the 48 contiguous United States, along with select areas of Alaska, Hawaii, and Canada. For locations not covered, consumers can either contact a local provider or coordinate with Felix Storch, Inc. to find nearby service options, which may qualify for partial reimbursement.

The warranty for this appliance is valid for two years from the date of purchase, provided the appliance is operated and maintained according to the instructions included with the product. The warrantor will cover the cost of factory-specified parts and repair labor needed to correct defects in materials or workmanship. Service must be performed by a designated service company.

All parts, except the compressor, are warranted for two years against manufacturing defects. Plastic parts, shelves, and cabinets are produced to commercially acceptable standards but are not covered for damages incurred during handling or for breakage.

5-YEAR COMPRESSOR WARRANTY

1. The compressor is covered for 5 years.
2. Replacement does not include labor.

ITEMS WARRANTOR WILL NOT PAY FOR:

1. Service calls to correct the installation of your appliance, to instruct you how to use your appliance, to replace or repair fuses or to correct wiring or plumbing.
2. Service calls to repair or replace appliance light bulbs or broken shelves. Consumable parts (such as filters) are excluded from warranty coverage.
3. Damage resulting from accident, alteration, misuse, abuse, fire, flood, acts of God, improper installation, installation not in accordance with electrical or plumbing codes, or use of products not approved by warrantor.
4. Replacement parts or repair labor costs for units operated outside the 48 contiguous United States, along with select areas of Alaska, Hawaii, and Canada.
5. Repairs to parts or systems resulting from unauthorized modifications made to the appliance.
6. Expenses for travel and transportation for product service in remote locations.
7. The removal and reinstallation of your appliance if it is installed in an inaccessible location or is not installed in accordance with published installation instructions.

DISCLAIMER OF IMPLIED WARRANTIES; LIMITATION OF REMEDIES

CUSTOMER'S SOLE AND EXCLUSIVE REMEDY UNDER THIS LIMITED WARRANTY SHALL BE PRODUCT REPAIR AS PROVIDED HEREIN. IMPLIED WARRANTIES, INCLUDING WARRANTIES OF MERCHANTABILITY OR FITNESS FOR A PARTICULAR PURPOSE, ARE LIMITED TO TWO YEARS. WARRANTOR SHALL NOT BE LIABLE FOR INCIDENTAL OR CONSEQUENTIAL DAMAGES. SOME STATES DO NOT ALLOW THE EXCLUSION OR LIMITATION OF INCIDENTAL OR CONSEQUENTIAL DAMAGES, OR LIMITATIONS ON THE DURATION OF IMPLIED WARRANTIES OF MERCHANTABILITY OR FITNESS, SO THESE EXCLUSIONS OR LIMITATIONS MAY NOT APPLY TO YOU. THIS WARRANTY GIVES YOU SPECIFIC LEGAL RIGHTS AND YOU MAY ALSO HAVE OTHER RIGHTS, WHICH VARY FROM STATE TO STATE.



WARNING: This product can expose you to chemicals including Nickel (Metallic) which is known to the State of California to cause cancer.

For more information go to www.P65Warnings.ca.gov

Note: Nickel is a component in all stainless steel and some other metallic compositions.

SUMMIT
COMMERCIAL

accucold

Revised: 2025-08-12