

NEST®

PRODUCT CATALOGUE

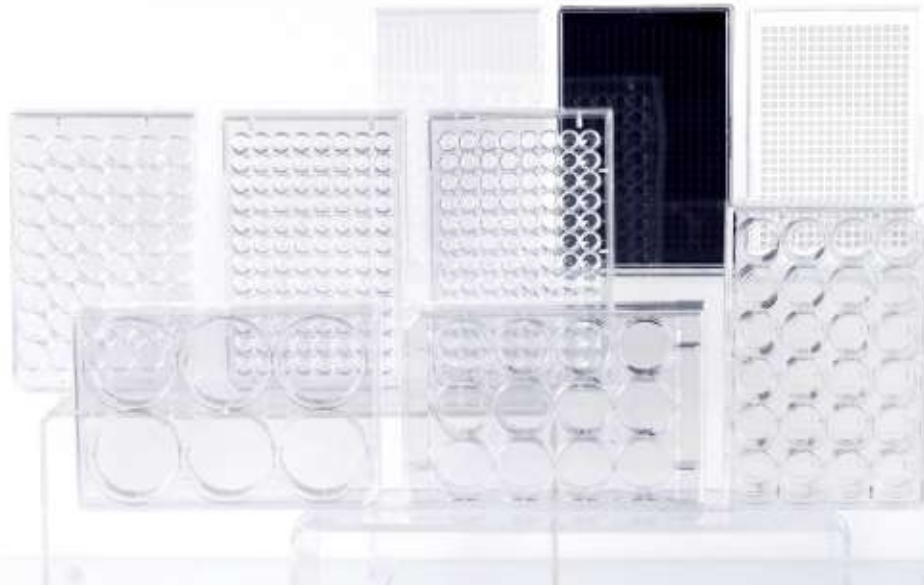

Cell Culture Plate



- Sterilized by E-beam, SAL=10⁻⁶.
- High clarity, 100% virgin polystyrene.
- The configuration complies with the ANSI-SBS format.
- The plate lid is designed with cut corners and a condensation ring, reducing the risk of contamination.
- Non-Pyrogenic, DNase/Rnase free.

- The bottom is flat and clear, with each hole labeled for easy differentiation.
- The plate features a non-slip ridge on the side for easy gripping, while the protruding points on the bottom help to prevent noise during transfer.

*The TC-treated ones are intended for adherent cell culture, while the non-treated ones are suitable for suspension cell culture.

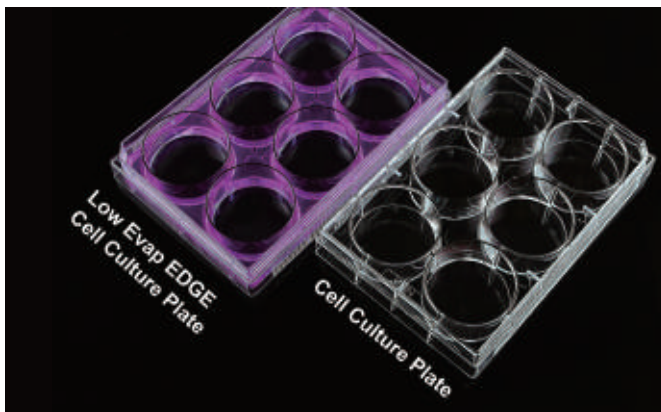

Low Evap EDGE Cell Culture Plate

Grooves are designed at the edge of the culture plate to help cells maintain their optimal state during cell culture. They provide a stable temperature and balanced humidity environment for the plate, which reduces or eliminates edge effects and ensures uniformity in cell growth.



Black/White Clear Bottom Cell Culture Plate

- The bottom of the wells is made of high-transparency PS material, ensuring uniform thickness and excellent light transmission performance. This material avoids optical distortion even under high magnification microscopy. On the other hand, the well walls are made of light-shielding PS material to prevent cross-contamination.
- Plates with a black frame are commonly used for fluorescence detection, while plates with a white frame are typically used for luminescence detection. Occasionally, white-framed plates are also used to enhance fluorescence signal intensity.

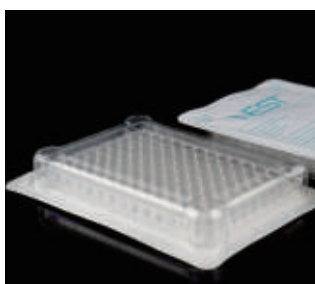

Individually Packaged



Plastic Bag Package

Product	Recommendation Experiment-Bottom Reading	Notes
White, transparent bottom	<ul style="list-style-type: none"> • Colorimetric Assay/ Absorbance • Chemiluminescence Method 	Cellular visualization operations permitted in cell detection and analysis and confocal microscopy experiments.
Black, transparent bottom	<ul style="list-style-type: none"> • Fluorescence Intensity Method (FI) • Fluorescence Resonance Energy Transfer (FRET) 	

Cell Culture Plate

Well Number	Cell Growth Area (cm ²)	Recommended Medium Volume (mL)	Bottom Type	Colour	Packaging	/Pack	/Case	Cat. No.			
								TC Treated	Non-Treated		
6 Well	9.5	1.9-2.9	□	Clear	Individually Packaged	1	50	703001	703011		
					Plastic Bag Package	10	50	703002	703012		
6 Well Low Evap EDGE Plate	Individually Packaged	1			50	714011	714001				
12 Well	3.6	0.76-1.14			□	Clear	Individually Packaged	1	50	712001	712011
							Plastic Bag Package	10	50	712002	712012
24 Well	1.9	0.38-0.57			□	Clear	Individually Packaged	1	50	702001	702011
							Plastic Bag Package	10	50	702002	702012
48 Well	0.88	0.19-0.285			□	Clear	Individually Packaged	1	50	748001	748011
							Plastic Bag Package	10	50	748002	748012
96 Well	0.32	0.1-0.2			□	Clear	Individually Packaged	1	100	701001	701011
							Plastic Bag Package	10	100	701002	701012
					U		Individually Packaged	1	100	701101	701111
			V	Individually Packaged			1	100	701201	701211	
			□	White	Individually Packaged		1	100	701301	701311	
				Black	Individually Packaged		/	/	/	/	
96 Well Clear PS Bottom	0.32	0.1-0.2	□	White, transparent bottom	Individually Packaged	1	30	701701	/		
				Black, transparent bottom	Individually Packaged	1	30	701401	/		
96 Well Low Evap EDGE Plate	0.32	0.1-0.2	□	Clear	Individually Packaged	1	100	713011	713001		
384 Well	0.11	0.025-0.05	□	Clear	Individually Packaged	1	100	761001	761011		
					Plastic Bag Package	10	100	761002	761012		
					Black	Individually Packaged	1	100	761301	761311	
					White	Individually Packaged	1	100	761601	761611	
					White, transparent bottom	Individually Packaged	1	30	/	/	
					Black, transparent bottom	Individually Packaged	1	30	/	/	

Technical Drawing of Cell Culture Plates

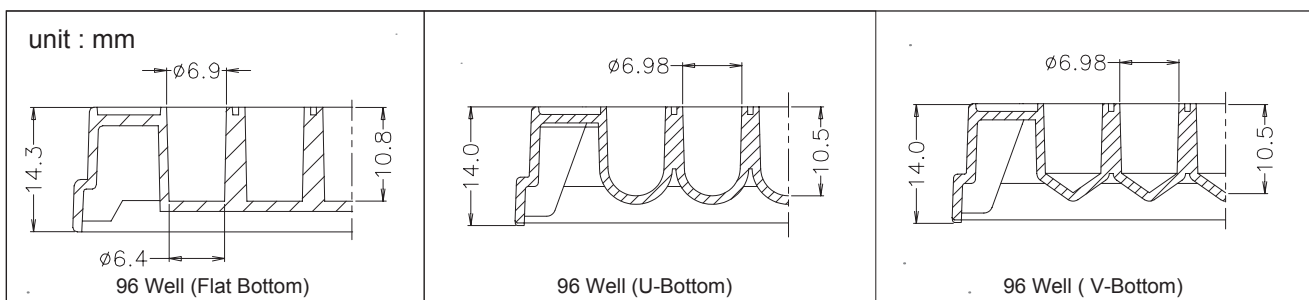
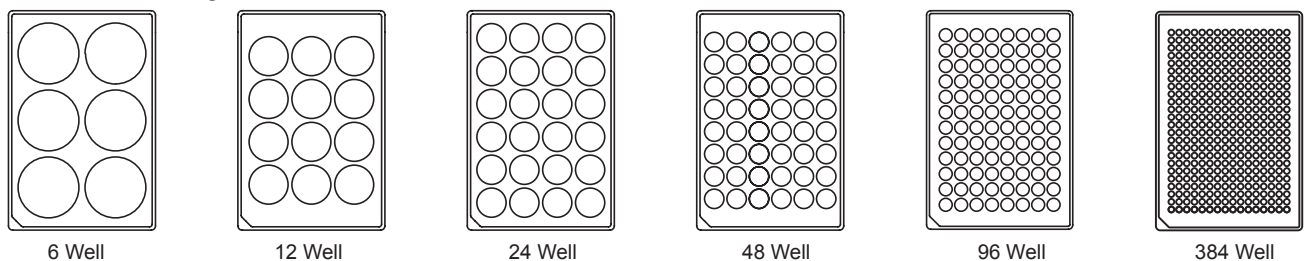

Cell Culture Insert

Cell and tissue culture technologies have an increasing importance in the fields of basic and applied life science. New culture vessels and new surfaces for cell adsorption are continuously emerging, in order to simulate the internal environment as much as possible for culture of some special cell lines. Logically, using permeable supports with a microporous membrane becomes the basic method for culturing these cells. Permeable supports may effectively improve the culture of polar cells, because these supports allow cells to secrete on and absorb molecules from their basal and apical surfaces to metabolize in a more natural way, as well as to stimulate the in vivo environment to the maximum extent for culturing of some special cell lines.

Features

- Sterilized by E-beam, SAL=10⁻⁶.
- Vacuum Plasma tissue culture treatment.
- Non-Pyrogenic, DNase/Rnase free.
- A rich selection of matching plates: 6-well, 12-well, 24-well.
- Passed the USP VI toxicity test.
- Cell culture plates are made of high clarity, 100% virgin polystyrene.
- Clear lot number for batch traceability.
- Innovative edge design for convenient sample loading.
- Low protein binding to ensure accurate results.
- Compatible with most solvents used for fixing and staining.

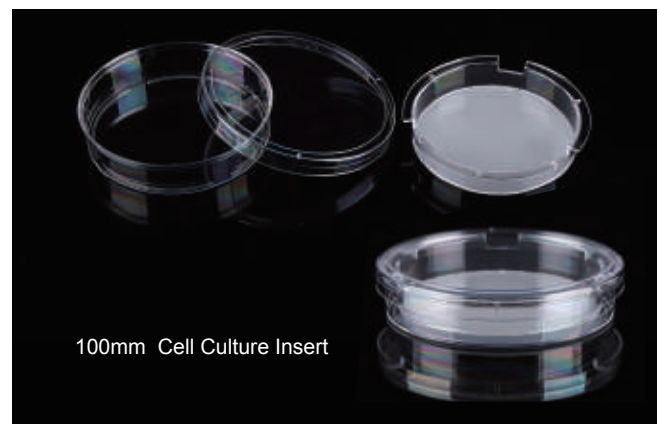
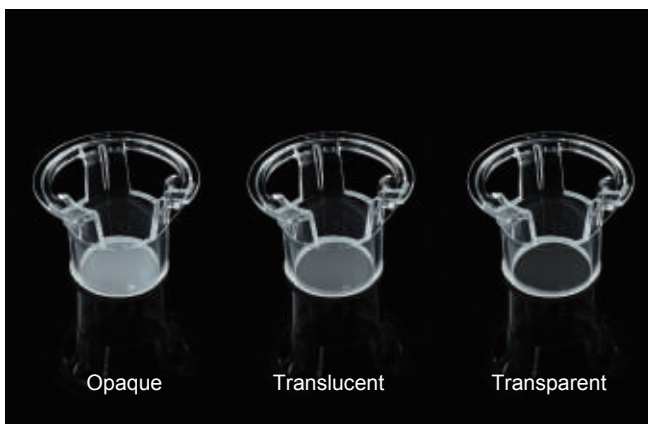
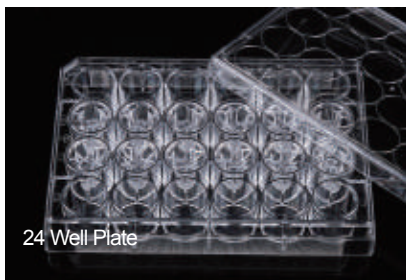
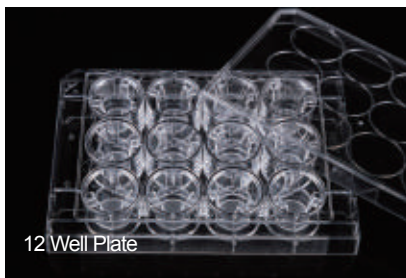
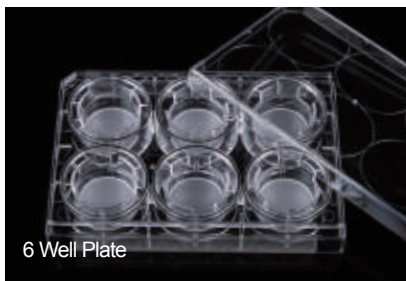

Application Directions and Types

Applications	Cells	Pore size of Membrane
ADME (transport and permeation of compounds through the enterocyte barrier)	Caco-2, MDCK	0.4 µm
Co-culture and cell differentiation, cell imaging	Primary cells, tumor, stem cells	0.4 µm, 1.0 µm
Cell migration and invasion (angiogenesis)	Endothelial cells	3.0 µm
Cyto-chemotaxis (migration) or endothelial migration	Leukocytes	
Axonal hyperplasia	Neurons	
Tumor cell migration and invasion	Tumor-derived cells	8.0 µm
Hematostasis or migration through endothelial cells	Leukocytes	
Co-culture	Tumor stem cells	
Transport and secretion of macromolecules or viruses		1.0 µm, 3.0 µm

Product Specification

Specifications	Insert (Pcs/Plate)	Insert Diameter (mm)	Volume of Each Well (mL)	Inner Volume of Insert (mL)	Membrane Growth Area of Insert (cm ²)	
						6 Well Plate
12 Well Plate	12	12	1.5	0.5	1.12	
24 Well Plate	12	6.5	0.6	0.1	0.33	
100mm Dish	1	75	13	9	44	
Pore Size of Membrane (µm)		0.4	1.0	3.0	5.0	8.0
Membrane Density (Well/cm ²)		1x10 ⁸	2x10 ⁷	2x10 ⁶	4x10 ⁵	1x10 ⁵



Cell Culture Insert

Order Information (Insert+Plate Configuration) Note: The inserts are TC-treated. Please refer to the table below to check if the plates are also TC-treated.

Pore Size (µm)	Description	Packaging		PC Membrane			PET Membrane		
		/Pack	/Case	Transparence	TC Treated	Non-Treated	Transparence	TC Treated	Non-Treated
0.4	6 Cell Culture Inserts + 6 Well Plate	6	24	Opaque	723101	723111	Opaque	723121	723131
	12 Cell Culture Inserts + 12 Well Plate	12	48	Opaque	724101	724111	Opaque	724121	724131
	12 Cell Culture Inserts + 24 Well Plate	12	48	Opaque	725101	725111	Opaque	725121	725131
1	6 Cell Culture Inserts + 6 Well Plate	6	24	Opaque	/	/	Opaque	723421	723431
	12 Cell Culture Inserts + 12 Well Plate	12	48	Opaque	/	/	Opaque	724421	724431
	12 Cell Culture Inserts + 24 Well Plate	12	48	Opaque	/	/	Opaque	725421	725431
3	6 Cell Culture Inserts + 6 Well Plate	6	24	Translucent	723001	723011	Translucent	723021	723031
	12 Cell Culture Inserts + 12 Well Plate	12	48	Translucent	724001	724011	Translucent	724021	724031
	12 Cell Culture Inserts + 24 Well Plate	12	48	Translucent	725001	725011	Translucent	725021	725031
	100 mm Cell Culture Insert-Dish	1	10	Translucent	726001	/	Translucent	/	/
5	12 Cell Culture Inserts + 12 Well Plate	12	48	Translucent	724201	724211	Translucent	/	/
	12 Cell Culture Inserts + 24 Well Plate	12	48	Translucent	725201	725211	Translucent	/	/
8	6 Cell Culture Inserts + 6 Well Plate	6	24	Translucent	723301	723311	Transparent	723321	723331
	12 Cell Culture Inserts + 12 Well Plate	12	48	Translucent	724301	724311	Transparent	724321	724331
	12 Cell Culture Inserts + 24 Well Plate	12	48	Translucent	725301	725311	Transparent	725321	725331

Cell Culture Inserts (Individual Blister Package)

Pore Size (µm)	Specification	Description	Packaging	PC Membrane		PET Membrane	
				Transparence	TC Treated	Transparence	TC Treated
0.4	6 well	Cell Culture Inserts	1 pc/blister, 8 pcs/plate, 48 pcs/case	/	/	Opaque	723122
	12 well	Cell Culture Inserts	1 pc/blister, 8 pcs/plate, 48 pcs/case	/	/	Opaque	724122
	24 well	Cell Culture Inserts	1 pc/blister, 8 pcs/plate, 48 pcs/case	/	/	Opaque	725122
8	24 well	Cell Culture Inserts	1 pc/blister, 8 pcs/plate, 48 pcs/case	Translucent	725302	/	/

Glass Bottom Cell Culture Dish & Plate

NEST glass bottom series are applied in confocal microscope, high resolution microscope, differential interference contrast microscope, polarized light microscope and phase contrast microscope for cell observation.

Features

- Can be used for live cell observation.
- Special bottom design for easy grip.
- Round cover glass inserts for good appearance.
- Medical adhesive glue to guarantee non-cytotoxicity.
- Sterilized by E-beam, SAL=10⁻⁶.
- Made of high clarity, 100% virgin polystyrene and high clarity glass as bottoms.
- High quality cover glass of standard thickness.

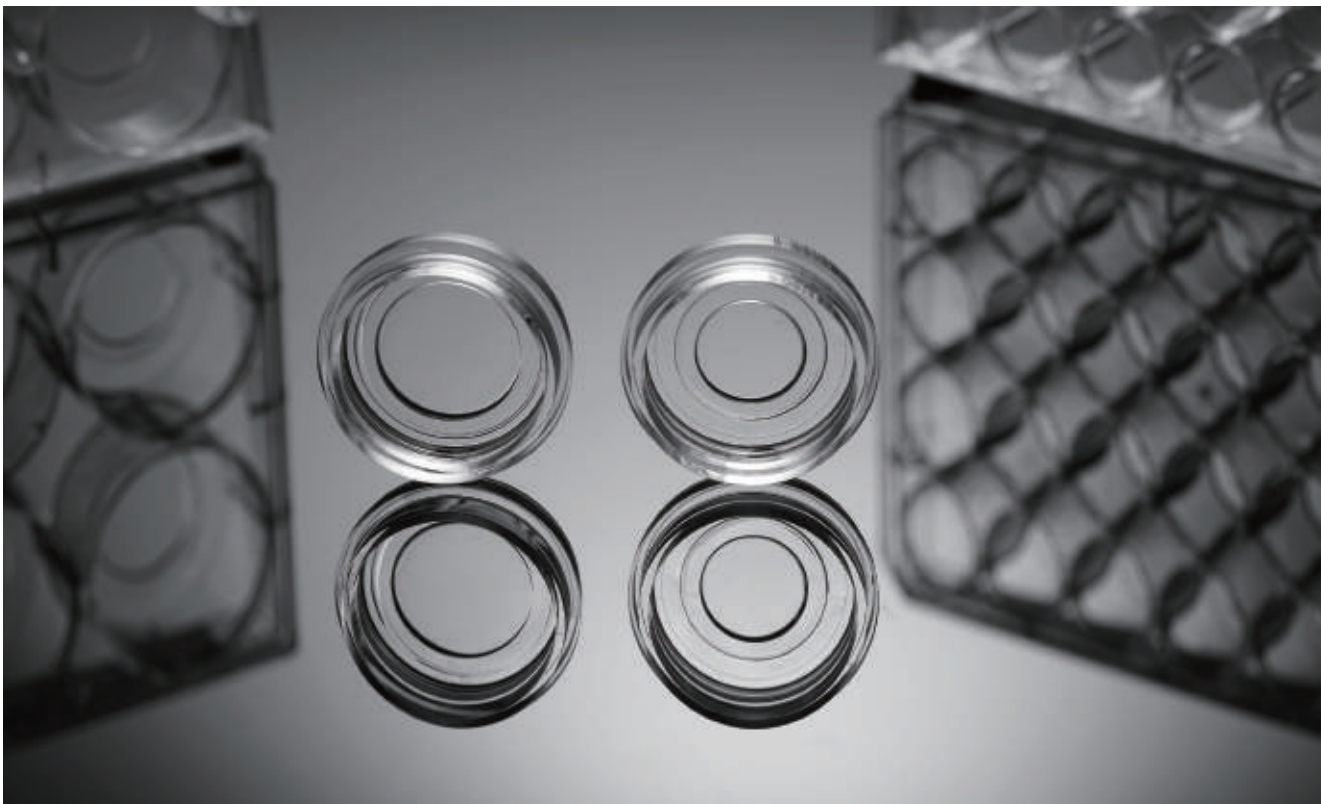
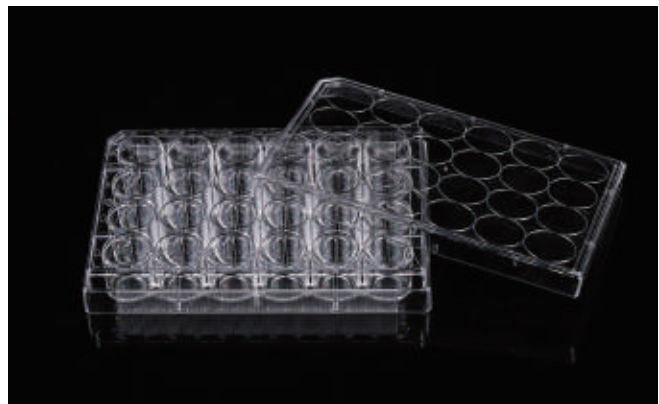
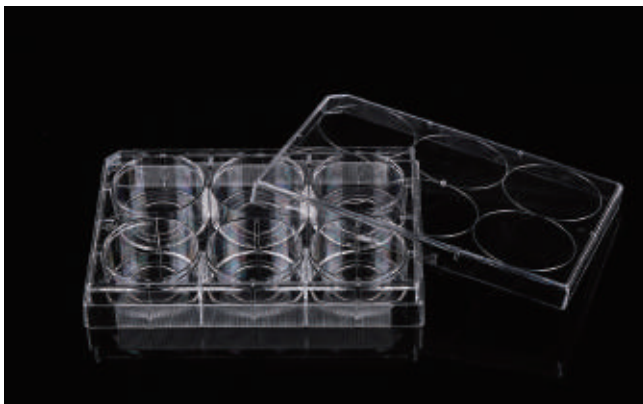

Glass Bottom Culture Dish

Type (mm)	Glass Diameter (mm)	Cultivation Area (cm ²)	TC	/Pack	/Case	Cat.No.
28.2	15	6.2	Yes	10	200	801002
28.2	20	6.2	Yes	10	200	801001
28.2	20	6.2	Yes	1	20	801021
28.2	15	6.2	Yes	1	20	801022

Blister package



Glass Bottom Culture Plate

Spec (Well)	Glass Diameter (mm)	Cultivation Area (cm ²)	TC	/Pack	/Case	Cat.No.
6	34.8	9.5	Yes	1	10	801004
24	15.6	1.9	Yes	1	10	801006

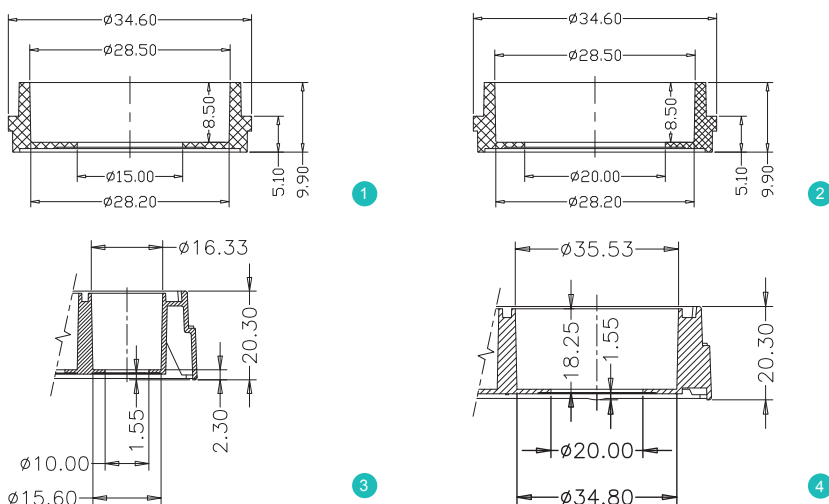

Unit: mm

- ① Φ 15 Glass Bottom Dish
- ② Φ 20 Glass Bottom Dish
- ③ 24 Well Glass Bottom Plate
- ④ 6 Well Glass Bottom Plate

Cover Glass

Features

- High quality glass, non-cytotoxic.
- Sterile, non-treated.
- Manufactured in class 100,000 clean room.
- Resistant to organic solvent.
- Autoclavable.
- Suitable for used in confocal experiment.



Glass Diameter (mm)	Thickness (mm)	/Pack	Application	Cat.No.
14	0.17	100	24 Well Cell Culture Plate	801010
15	0.17	100	24 Well Cell Culture Plate	801007
18	0.17	100	12 Well Cell Culture Plate	801011
20	0.17	100	12 Well Cell Culture Plate	801008
25	0.17	100	6 Well Cell Culture Plate	801009

Tips:

sterilization: If the glass needs to be sterilized after a long period of non-use, it is recommended to wrap it in tin foil and sterilization it at 180°C in a metal container for two hours.

Coating: Coating can be done with polylysine, collagen, extracellular matrix, and some commercially available reagents containing layer adhesive protein, fibronectin, and proteoglycan, which can improve cell adhesion.



Cell Culture Dish

NEST cell culture dishes are ideal for all types of culturing where microscopic examination is required. Numeric indicators on the bottom of each plate allow users to identify the location of cells.

Features

- High clarity, 100% virgin polystyrene.
- Flat transparent surface for distortion-free observation.
- Vacuum plasma TC treatment, excellent cell adsorption.
- Stackable for easy storage and handling.
- Sterilized by E-beam, SAL=10⁻⁶.
- Non-Pyrogenic, DNase/Rnase free.

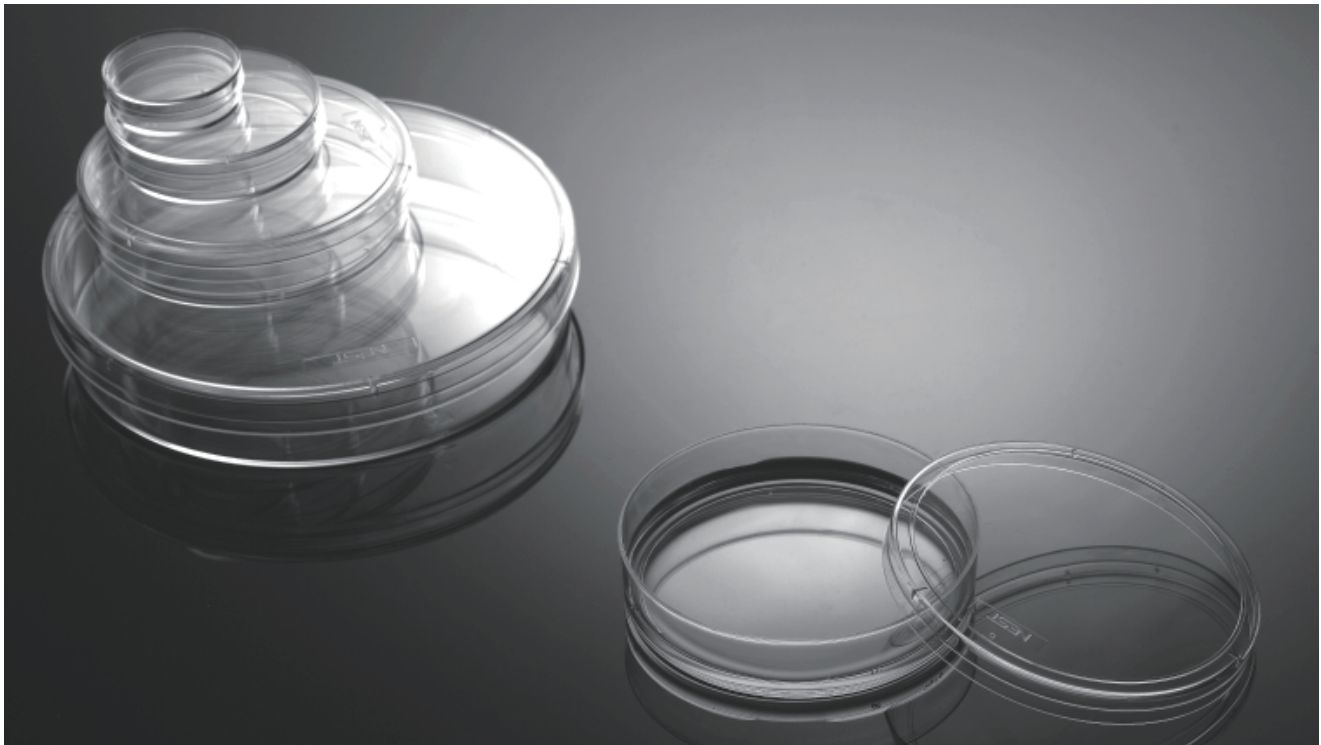

Sterilized Packing

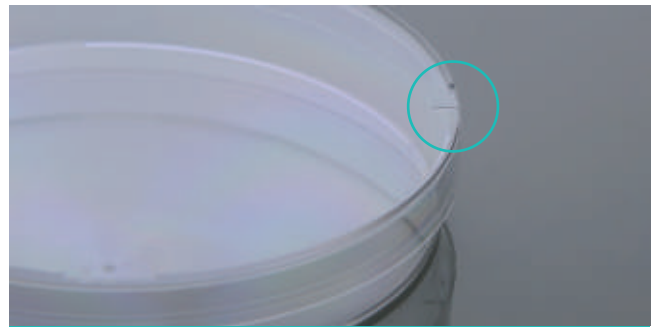

Vent points for Gas Exchange

Feature

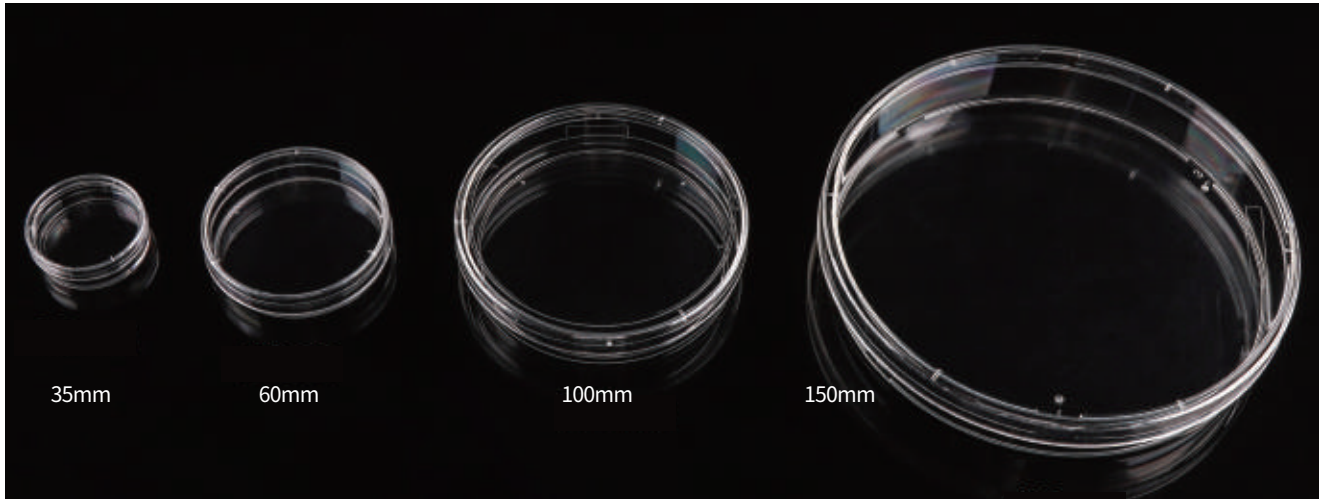

35 mm Dish with Gripping Ring

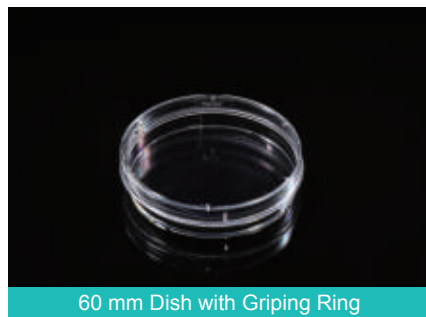

60 mm Dish with Gripping Ring



100 mm Dish with Gripping Ring

Cell Culture Dish

Specification (mm)	Height (mm)	Cell Growth Area (cm ²)	Rcommended Medium Volume (mL)	Types	Packing		Cat.No.
					/Pack	/Case	
35	12	8.5	1.8-2.7	Regular	20	25	706001
				Easy Grip	20	25	706201
60	15	22.9	4.2-6.3	Regular	20	25	705001
				Easy Grip	20	25	705201
100	20	57.6	11-16.5	Regular	5	60	704004
					10	30	704002
					20	15	704001
		Easy Grip		10	30	704202	
				20	15	704201	
				5	20	715001	

Actual diameter is smaller than the indicated
 35 mm dish bottom inner diameter: 35.0 mm
 60 mm dish bottom inner diameter: 54.0 mm
 100 mm dish bottom inner diameter: 85.6 mm
 150 mm dish bottom inner diameter: 138.2 mm
 100 mm easy grip dish bottom inner diameter: 86.9 mm

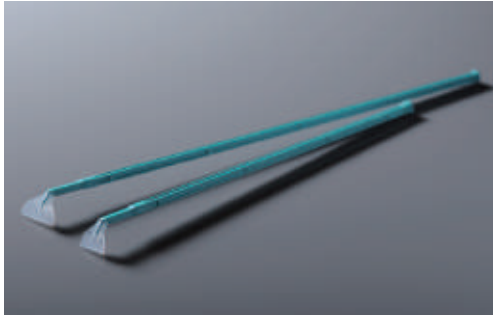

Cell Scraper

Features

- Free rotating blade, makes the blade twist to the right direction.
- Two sizes are available.
- Easy-tear sterile packing.
- Sterilized by E-beam, SAL=10⁻⁶.
- Non-Pyrogenic, DNase/Rnase free.
- Individually packaged.

Spec(mm)		Colour	Sterile	/Case	Cat.No.
Total Length	Blade Width				
220	13	Blue handle + transparent blade	Yes	100	710001
280	20	Blue handle + transparent blade	Yes	100	710011
