



NEXTVEIN

Projection Vein Finder

User Manual

CE

IMPORTANT

Prior to installation and use of the Projection Vein Finder (device), read all instructions in this user manual and the manuals for the hands-free stands.

The device is intended for qualified or trained medical personnel only. Please follow these instructions to use the device.

Note that the device is not a substitute for professional clinical judgments. It is only for assistance in the observation of veins and use in medical training.

CONTENTS

Product Overview	2
Intended Use	3
Warnings and Cautions	4
Appearance and Components	8
Items Included With Device	9
Indicators and Buttons	10
Charging the Device.....	13
Using The Vein Visualization Device.....	14
About the always-on mode.....	14
About The Hands Free Stands	15
Maintenance & Troubleshooting	16
Storage	19
Warranty	21
Technical Specifications.....	22
Manufacturing Information.....	27

PRODUCT OVERVIEW

The NextVein Projection Vein Finder is a hand-held, vein scanning and projection device that assists trained medical personnel to locate a suitable position for venipuncture and other medical procedures requiring the location of superficial veins.

The device is equipped with a CMOS camera. As hemoglobin has a stronger absorption of near-infrared light than surrounding tissue, the camera can detect the intensity of infrared light and display the position of veins on patients' skin using advanced digital image processing.

The device can help clinicians locate and observe the veins for intravenous injection, blood-draw and vein avoidance.

The device can reduce the pain of repeated venipuncture by accurately locating the veins of patients, especially those of children and people with high BMIs. These patients may often have difficult venous access (DVA) with veins that are hard to locate. This is stressful for both clinicians and patients.

This device can:

- Demonstrate the location of veins in medical training;
- Assist clinicians in locating and observing veins of patients;
- Help clinicians with the evaluation of veins;
- Help clinicians with venipuncture for blood draw;
- Reduce patients' anxiety caused by repeated attempts.

The device only serves as an assistance in locating veins and for training medical personnel. Please note that it is NOT a substitute for visual and tactile judgment which is based on professional medical knowledge.

INTENDED USE

The Projection Vein Finder is used for observing and locating superficial veins to assist medical personnel in performing venipuncture procedures such as intravenous vein access and blood draw.

WARNINGS AND CAUTIONS

PRECAUTIONS

- Read this User Manual before the first use and strictly follow our instructions.
- Before the first use or after shipment, check the projection accuracy by using the Accuracy Test Card.
- Check that the accessories are intact before using. If the accessories are damaged, do not use them and contact your distributor or customer service.
- Do not treat the device as a substitute for professional clinical judgment. The device is only for assistance in locating and observing veins.
- Keep the device away from children.
- The device is a Class I medical apparatus, which is safe and can be operated continuously.
- Scars, tattoos, hair and some skin conditions may interfere with the ability of the device to accurately observe veins.
- Portable or mobile Radio Frequency equipment may affect the performance of the device. While using it, keep it away from intense EMI (Electromagnetic Interference), such as mobile phones, microwaves and similar equipment.
- Use the device with a stand. This will help reduce the amount of time you hold the device and avoid patient contact.
- Place the adapter in a place that allows it to be easily plugged in and unplugged.

CAUTIONS

- The device will not perform accurately if the environmental conditions do not meet the requirements.
- Use only the accessories provided along with the device. Using third-party accessories may damage components and lead to hazards.

- The device contains a replaceable battery. Please strictly follow our instructions on battery storage, transportation and operation.
- The battery provided is a lithium ion battery. If you are going to store the device for an extended period please fully charge the battery and properly store it. The storage life of a battery is one year.
- Do not immerse any part of the device or the accessories into liquid, or splash liquid on the device or the accessories. If any liquid is splashed on the device when it is operating or being charged, stop using it and power it off immediately.
- Do not puncture, disassemble or modify any part of the device. We do not take any legal responsibility for the consequences resulting from unauthorized modifications.
- Do not improperly discard the device. As the device contains a battery, it must be disposed of in accordance with the regulations in your country.



WARNINGS

- Do not use the device in inflammable and explosive environments, or environments where there are inflammable and explosive goods.
- Do not keep the device close to or stack with other equipment. Electromagnetic Interference may result in the malfunction of device. If needed, verify and insure that it performs accurately.
- The device is intended to be used in industrial environments. Due to the conducted and radiated emissions of the device, there are potential Electromagnetic Compatibility hazards in other environments.
- To avoid the risk of electric shock, the device must only be connected to a supply main with protective earth.
- Under some SINGLE FAULT CONDITIONS, the temperature of device's projection area could get hot and there is possible RISK of a burn if touched.



CONTRAINDICATIONS

- The infrared light of device is safe for eyes according to “GB/T 20145-2006/CIE S 009/E:2002 Photo-biological Safety Of Lamps And Lamp Systems” but we highly recommend that you do NOT shine the infrared light on eyes.
- The device is effective in the identification of veins. It is not for identification of arteries.
- Do not use the product as a diagnostic device or for any therapeutic purpose.

Symbol	Description	Symbol	Description
	Date of Manufacture		General Warning Sign
	Manufacturer		Caution
	Use-by Date		Serial Number
	Refer to Instruction Manual/Booklet		Waste Electrical and Electronic Equipment
	Stacking Limit by Number		Keep Away from Rain
	This Way Up		Fragile Handle with Care
	Keep Away from Sunlight		Atmospheric Pressure Limitation
	Humidity Limitation		Temperature Limits
	Authorized Representative in the European Community		Protective Earth (Ground)

APPEARANCE AND COMPONENTS

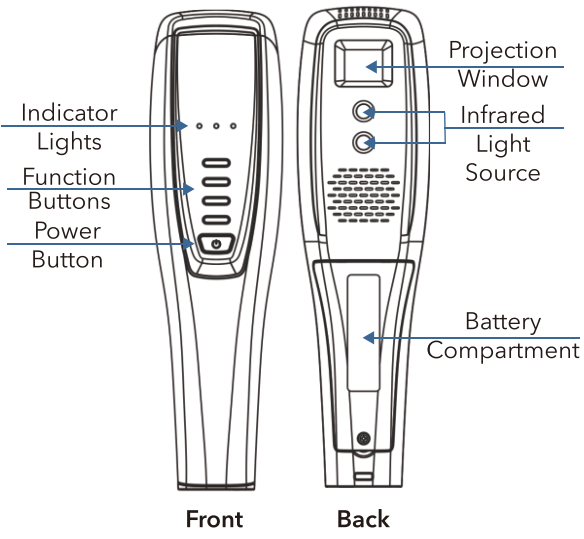
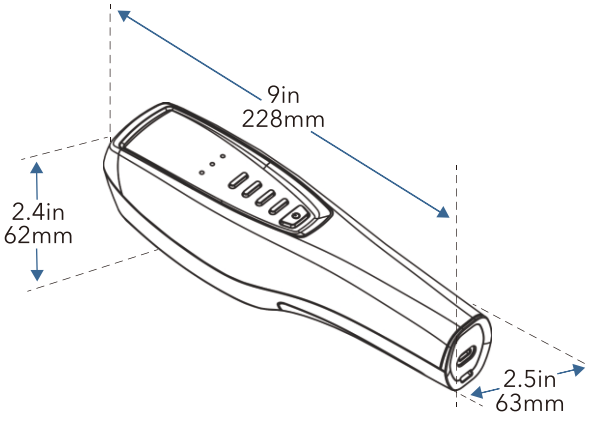



Side

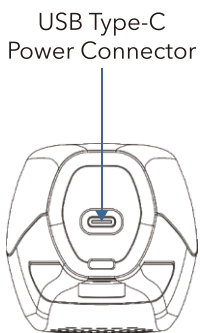



Bottom

ITEMS INCLUDED WITH DEVICE



- Projection Vein Finder device
- Power Adapter
- AC Cable
- This User Manual
- Accuracy Test Card
- Qualification Certificate

INDICATORS AND BUTTONS

The device has three green lights on the front panel.

Indicator	Status	Meaning
	On	The device is turned on.
	Off	The device is turned off.
	Fast-Blinking	The device is in standby mode and the vein projection is off. Pressing the power button turns the vein projection back on.
	Slow-Blinking	The device is in always-on mode. To exit always-on mode, disconnect external power.
	On	Connected to external power and charging.
	Off	Either fully charged or unit is not connected to external power.
	Slow blink	Operating on battery; Charge level is good.
	Fast blink	Operating on Battery; Charge immediately. Note: the status bar in the projection provides additional information about the battery level.
	On	Connected to power supply.
	Off	Not connected to power supply.

The device has five buttons on the front panel.

Button	Purpose
A	Change projection to dark vein lines on a white background.
B	Change projection to green lines on a dark background.
C	Change projection to green lines on a dark background with a small projection size.
	Pressing this button for three seconds places the device in always-on mode. This mode is only available while connected to an external power.
	<p>This button turns the power on. Subsequent presses toggle standby mode.</p> <ul style="list-style-type: none">• Hold the button for 1 seconds to turn on. This prevents accidentally turning on the device and draining the battery.• It will take less than 8 seconds for the device to turn on.• While the device is on, a short press enters standby mode and turns off the projection [the  indicator starts blinking].• Another short press turns the projection back on.• When in always-on mode this button is not active. To exit always-on mode, disconnect external power.• Note: When the device is in standby mode, it will automatically turn off after 5 minutes.

PROJECTION INFORMATION DISPLAY

In addition to the vein pattern, the projection includes useful information about the status of the device.

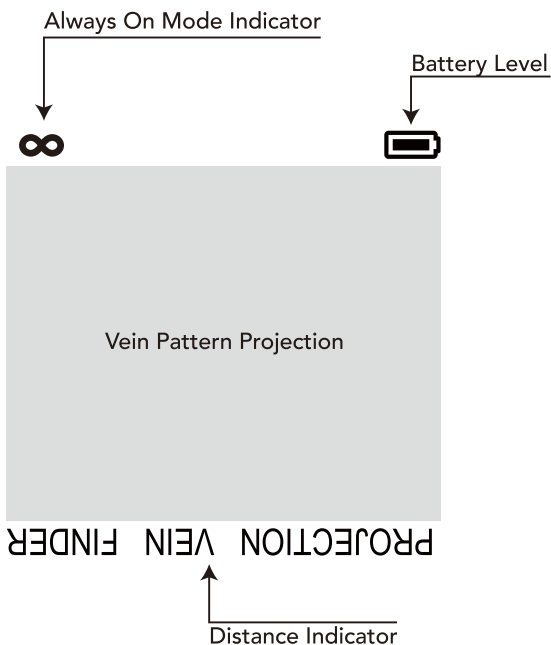

Battery Level	The battery indicator provides four levels. When four bars are seen, the device is fully charged. When one bar is shown, it is time to charge the battery.
Always On	When displayed the device is in always on mode.
Distance Indicator	The text "PROJECTION VEIN FINDER" is always shown. When this text is in focus, the device is the proper distance from the patient's skin.

CHARGING THE DEVICE

The supplied power adapter can be used to charge the battery and to operate the device.

To use the power supply:

- Plug the connector into the socket on the bottom of the device;
- Plug the mains connector in;
- Ensure that all connections are secure;
- Verify that the indicator  is on.



WARNING

- Use only the accessories provided along with the device. Using third-party accessories will damage the components and lead to hazards.

ABOUT THE BATTERY

- The device uses a high performance 6800mAh rechargeable lithium ion battery.
- As with all rechargeable batteries, as it ages, it will provide less run time. Change the battery if the run time becomes too short.
- If will not be using the device for an extended period, please fully charge the battery and properly store it.

USING THE VEIN VISUALIZATION DEVICE

To project the image of veins:

- Hold the device over the surface of the skin at approximately 8" (21cm) plus or minus 1" (3cm) away from the body;
- The device is 9" (23cm) tall so the height of the device is a helpful tool for determining distance;
- Adjust the distance until the words on the bottom bar of the projection are in focus;
- Project the image on the area of interest;
- Once a vein is selected, return the device to its hand free stand and perform the procedure.

ABOUT THE ALWAYS-ON MODE

The always-on mode is designed for uses where it is desirable for the device to remain on for a long time such as aesthetics procedures. It is not intended for shorter procedures such as IV starts.

The always-on mode is only available while the device is connected to external power.

To enter always-on mode, press the infinity button (∞) for three seconds. The  indicator will begin blinking slowly.

To exit the always-on mode, disconnect from external power.

ABOUT THE HANDS FREE STANDS

The device is able to quickly convert from hand-held for rapid patient assessment to hands-free using one of the optional accessory stands.

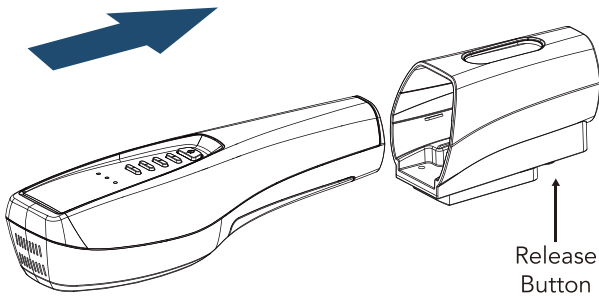

At the end of the arm is a quick-attach cup which allows the device to be quickly converted to and from hands free. Ensure that the device is securely fastened into the cup and press the release button on the bottom of the cup to remove the device.

Please refer to the Stand Installation Instructions for specifics on the device you have selected.

MAINTENANCE & TROUBLESHOOTING

CLEANING

Always follow the cleaning protocols for your facility. To keep the device in good condition and prolong its service life, regularly clean the device.

To clean the device:

- Power off the device;
- Gently clean the body of device with a pre-moistened wipe with 75% alcohol or Benzalkonium bromide;
- Additional cleaning materials may be approved. Please visit www.nextvein.com/service for more information.
- To clean the projection window use an a non-abrasive 100% alcohol (ethanol) wipe.

CAUTIONS

- The device must be powered off when being cleaned;
- Do not immerse any part of the device or the adapter into liquid, or splash liquid on the device or the adapter.
- The wipes used on the device should be wet, but not dripping.

CHECKING PROJECTION ACCURACY

As the device is a medical apparatus, use the Accuracy Test Card to check the projection accuracy before the first use or after assembly or shipping.

To check the accuracy:

- Press the button and hold for 1 seconds to power on the device; The device will start to project in less than 8 seconds;
- Place the device in a stand, if available;
- Project the output image to the Accuracy Test Card;

- Adjust the distance between the projection window and the Accuracy Test Card to an optimum (the words on the bottom bar are clear);
- Observe whether there is deviation between the projection and the card;

If the deviation is less than 1mm (0.04"), the device is in good condition; if the deviation is greater than 1mm (0.04"), stop using the device and contact customer service.

STATEMENT

The manufacturer will make available on request circuit diagrams, component part lists, descriptions, calibration instructions, or other information that will assist service personal to repair those parts of the device that are designated by manufacturer as repairable by service personal.

TROUBLESHOOTING

Issue	Possible Reason(s)	Action
The device is powered on but no image is displayed	The battery is discharged.	Charge the battery for at least 1 hour and make sure the indicator lights are correct
The indicator lights do not indicate power when plugged in.	The power adapter isn't properly connected or is not working.	Check the connection or try a different power adapter.
There are spots in the projection that move when the device is moved.	The projection window is dirty.	Clean the projection window.
The battery life is less than expected.	The battery is not being fully charged or has had excessive charge-discharge cycles.	Charge the unit for at least 5 hours and try again. Contact NextVein if this does not help for battery replacement options.
The device is not working or the projection has frozen.	The device may be too hot.	Turn the unit off for 1/2 hour or until the device cools down

STORAGE

To keep the device in good condition and for a longer service life, please store the device according to the environmental requirements below.

In Use	Temperature	5°C to 40°C 5°F to 104°F
	Humidity	≤ 80% RH non-condensing
	Atmospheric pressure	70~106 kPa to 10,000ft
Storage & Transportation	Temperature	-20°C to 55°C -4°F to 131°F
	Humidity	≤ 80% RH non-condensing
	Atmospheric pressure	70~106 kPa to 10,000ft



WARNING

- The device is a medical apparatus. To ensure its service life and its accuracy, please store and transport it properly;
- Note that high humidity will cause malfunctions of the device;
- Excessive vibration will damage the components of the device and reduce its accuracy.

BATTERY MAINTENANCE & STORAGE

- The battery is replaceable by a qualified biomedical technician. Instructions for changing the battery are included with the replacement battery.
- The device must be powered off when changing the battery.
- Like all rechargeable batteries, the capacity of the battery will decline based on the number of charge and recharge cycles.
- You can order a replacement battery when the run time reduces to an unacceptable level.
- If you plan on storing the device for an extended period, please fully charge the battery prior to storage. The battery will discharge over time and if it is allowed to completely discharge it may need to be replaced.
- The battery must be collected, recycled or disposed of in an environmentally sound manner in accordance with the regulations in your country.



WARNING

- Incorrect replacement of battery will lead to leakage and other hazards.

WARRANTY

The system comes with a one year limited manufacturers warranty. Additional service entitlements may be available based on your location. Please see nextvein.com/warranty or contact your distributor for more information.

LIMITATION OF LIABILITY

We shall not be liable for any event in the following:

- The device has not been used for intended use;
- The device has been operated by unqualified or untrained personnel
- You have failed to follow our instructions when operating the device;
- The device has been disassembled or modified without authorization;
- Any malfunction that is resulted from misuse, abnormal storage or operating environments, or deliberate damage.

TECHNICAL SPECIFICATIONS

Product Model	V800NV
Electric Shock Proof Classification	Class I
Weight	350g 12oz
Size	228 x 63 x 62 mm 9" x 2.5" x 2.4"
Power Adapter	Input: AC 100-240V 50/60Hz Output: DC 12V
Battery	DC 3.7V 6800mAh
Battery Life on Full	4.5 hours (maximum)
Charge Time	3.5 hours (minimum)
Water Ingress	IPx0 No ingress protection
Optimal Projection Distance	210±30mm 8.3"±1.2"
Light Source	Near infrared light
Infrared Wavelength	850 nm
Infrared Radiation Energy	≤0.6mW/cm ²

- Software Version:V107.0
- Fuse : 4A ,45V AC, $I_{interrupting}=50A$

CAUTION

- The EMC of the device is complied with IEC 60601-1-2:2014/EN60601-1-2:2015.
- Use the device according to EMC information provided in this user manual.
- Portable or mobile RF (Radio Frequency) equipment may affect the performance of the device. When using the device, keep it away from intense EMI (Electromagnetic Interference), such as mobile phones, microwave and other equipment.

 **WARNING**

- Do not keep the device close to or stack with other equipment.
- If you have to, verify and insure that it performs accurately.
- The device is intended to be used in industrial environments. Due to the conducted disturbance and the radiation disturbance of the device, there are potential EMC (Electromagnetic Compatibility) hazards in other environments.
- Except the transducer and the cable sold as internal components by the manufacturer of the device or the system, using other transducers, cables or other accessories may result in increased electromagnetic emissions or decreased electromagnetic immunity of the device or the system.
- Using transducers, cables or other accessories unspecified in this user manual may result in increased electromagnetic emissions or decreased electromagnetic immunity of the device or the system.

Guidance and Manufacturer's Declaration Electromagnetic Emissions The device is intended for use in the electromagnetic environment specified below. Users should assure that it is used in such an environment.		
Emissions test	Compliance	Electromagnetic Environment - Guidance
RF emissions CISPR 11	Group 1	The device uses RF energy only for its internal function. Therefore, its RF emissions are very low and are not likely to cause any interference in nearby electronics.
RF emissions CISPR 11	Class A	The device is suitable for use in all establishments other than domestic and those directly connected to the public low-voltage power supply network that supplies buildings used for domestic purposes.
Harmonic emissions IEC 61000-3-2	Class A	
Voltage Fluctuations IEC 61000-3-3	Complies	

Guidance and Manufacturer's Declaration Electromagnetic Immunity The device is intended for use in the electromagnetic environment specified below. Users should assure that it is used in such an environment.			
Immunity Test	IEC60601 Test Level	Compliance	Electromagnetic Environment - Guidance
Electrostatic discharge (ESD) IEC 61000-4-2	± 8 kV contact ± 15 kV air	± 8 kV contact ± 15 kV air	Floors should be wood, concrete, or ceramic tile. If floors are covered with synthetic material, the relative humidity should be at least 30 %.

Electrical fast transient/burst IEC 61000-4-4	+2 kV for power supply lines ±1 kV for input/output lines	± 2 kV for power supply lines ± 1 kV for input output lines.	Mains power quality should be that of a typical commercial or hospital environment.
Surge IEC 61000-4-5	±1kV line(s) to line(s) ± 2 kV line(s) to earth	±1kV line(s) to line(s) ± 2 kV line(s) to earth	Mains power quality should be that of a typical commercial or hospital environment.
Voltage dips, short interruptions and voltage variations on power supply input lines IEC 61000-4-11	0% U_T (100% dip in U_T) for 0.5 cycle, at 0°, 45°, 90°, 135°, 180°, 225°, 270° and 315° 0% U_T (100% dip in U_T), for 1 cycle, at 0° 70% U_T (30% dip in U_T), for 25 cycle, at 0° 0% U_T (100% dip in U_T), for 5 s	0% U_T (100% dip in U_T) for 0.5 cycle, at 0°, 45°, 90°, 135°, 180°, 225°, 270° and 315° 0% U_T (100% dip in U_T), for 1 cycle, at 0° 70% U_T (30% dip in U_T), for 25 cycle, at 0° 0% U_T (100% dip in U_T), for 5 s	Mains power quality should be that of a typical commercial or hospital environment. If the user of the device requires continued operation during power mains interruptions, it is recommended that the device be powered from an uninterruptible power supply or a battery.
Power frequency (50/60Hz) magnetic field IEC 61000-4 -8	30A/m	30A/m	Power frequency magnetic fields should be at levels characteristic of a typical location in a typical commercial or hospital environment.
NOTE: U_T is the A.C. mains voltage prior to application of the test level.			

Recommended separation distances between portable and mobile RF communications equipment and the Projection Vein Finder
 The device is intended for using in an electromagnetic environment in which radiated RF disturbances are controlled. The customer or the user of the device can help prevent electromagnetic interference by maintaining a minimum distance between portable and mobile RF communications equipment (transmitters) and the device as recommended below, according to the maximum output power of the communications equipment.

Rated Maximum Output power of transmitter/ W	Separation distance according to frequency of transmitter/m		
	150 kHz~80 MHz $d=1.2\sqrt{P}$	80 MHz~800 MHz $d=1.2\sqrt{P}$	800 MHz ~ 2.5 GHz $d=2.3\sqrt{P}$
0.01	0.12	0.12	0.23
0.1	0.38	0.38	0.73
1	1.2	1.2	2.3
10	3.8	3.8	7.3
100	12	12	23

For transmitters rated at a maximum output power not listed above the recommended separation distance in meters (m) can be estimated and identified using the equation applicable to the frequency of the transmitter, where P is the maximum output power rating or the transmitter in watts (W) according to the transmitter manufacturer.

NOTE 1 : At 80 MHz and 800 MHz the higher frequency range applies.

NOTE 2: These guidelines may not apply in all situations. Electromagnetic propagation is affected by absorption and reflection from structures, objects and people.

NEXTVEIN

L1002C