

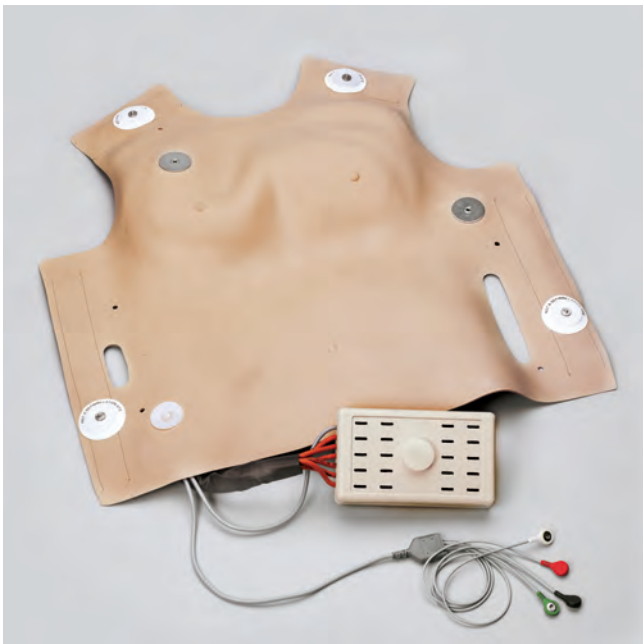

CRISIS™ System
Defibrillation Chest Skin
LF03652U
INSTRUCTION MANUAL



5-Year Warranty

ABOUT THE SIMULATOR

The **CRISIS™** System Defibrillation Chest Skin has been designed to be placed on the **CPARLENE®** brand of CPR manikins (full body “Airway Larry” manikins as well as Adult Airway Management Trainer Torso and both Advanced and “Airway Larry” Airway Management Torso Trainers) to enable you, the customer, to safely defibrillate.

The **CRISIS™** System Defibrillation Chest Skin will enable you to practice defibrillation using manual, semiautomatic, and automatic external defibrillators (AEDs). When using any one of the above listed types of defibrillators in training, always follow the recommended operating procedures for that particular defibrillator. The Defibrillation Chest Skin has been designed to absorb a maximum of 360 joules of energy**. Although capable of absorbing 360 joules, we recommend that the smallest energy level possible be used while training with the skin. In addition, the Defibrillation Chest Skin also includes 4 ECG sites and the ability to connect to the **Life/form®** Interactive ECG Simulator (LF03670U), sold separately. The Interactive ECG Simulator allows for pacing and wave form practice. The Interactive ECG Simulator products 17 adult/pediatric rhythms.

Note: Prior to removing the upper compression plate, you may need to disconnect the lung airway/stomach system, depending on which **Life/form®** manikin you are updating.

LIST OF COMPONENTS

- Defibrillation ECG Chest Skin with Load Box
- Four Lead Snap Cable Connected
- Set of Large Thread Screws
- Set of Bolts with Washers
- Self-adhesive foam pieces

****Note:** 360 joules is the maximum energy level that Nasco recommends administering to the defibrillation chest skin. Energy levels in excess of 360 joules may cause irreparable damage to the chest skin, circuitry, and patient simulator being used — thus voiding Nasco’s warranty and endangering your equipment. Nasco assumes no liability for damage or injury that may be caused by the use and/or misuse of this equipment. All normal safety precautions for defibrillation training should be followed and energy levels should be minimized. Nasco did not design nor intend this defibrillation chest skin to be used as anything other than a training apparatus for defibrillation.



SET UP

The **CRISIS™** System Defibrillation Chest Skin has been designed to replace the standard outer chest skin on **Life/form®** brand Full Body and Torso CPR and Airway Training manikins, thus enabling you to safely defibrillate.

Please follow the setup procedures for the type of manikin (torso with or without legs) on which you wish to place the **CRISIS™** System Defibrillation Chest Skin.

INSTALLATION INSTRUCTIONS

The load box for the **CRISIS™** System Defibrillation Chest Skin is installed the same way in every version of **Life/form®** manikins, regardless of when you purchased it or the version you purchased.

REMOVING THE REGULAR CHEST SKIN

In order to install the Defibrillation Chest Skin, the outer chest skin currently in place on the manikin must be removed.

INSTALLING THE LOAD BOX

The next step is to install the load box for the Defibrillation Chest Skin. The load box is attached to the skin via one large cable. This is the device that will absorb the energy being administered to the chest skin while defibrillating. **Note: It is very important that this load box is installed properly!**

Once you have the chest skin removed, you must next remove the rib plate and the upper compression plate. **Note:** The next step is to attach the self-adhesive foam pieces to the back plate of the manikin. (See figure 1).

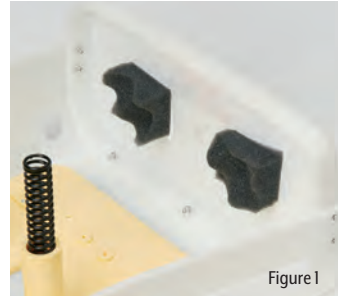

Figure 1

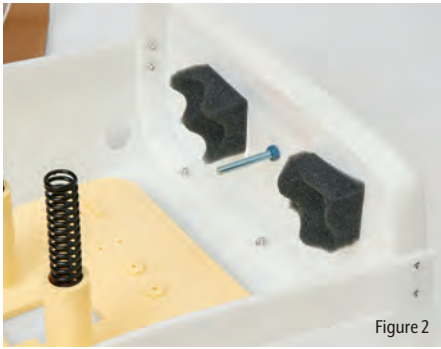

Figure 2



Figure 3

If you have a manikin with legs attached to it, you will already have four screws with washers and wing nuts holding the legs on. To attach the load box in this situation, just adhere the self-adhesive foam pieces to the back plate inside.

SECURING THE LOAD BOX

Now that the foam pieces are in place, screw the load box onto the single screw. (See figure 2).

REPLACING THE SKIN

Now that you have secured the load box, uncoil the smaller cable that has the four lead snaps attached. These four lead snaps will eventually be attached to your arrhythmia generator or patient simulator cable. For now, simply uncoil the cable and allow it to hang freely from the manikin.

Next, replace the chest plates that you removed earlier and lay the **CRISIS™** System Defibrillation Chest Skin on top of the chest of the manikin.

The hook-and-loop fastener has already been sewn onto the skin. Simply line up the hook-and-loop fastener and you are all set. (See figure 3).

Actual product may vary slightly from photo. Nasco reserves the right to change product color, materials, supplies, or function as needed.

DEFIBRILLATING THE MANIKIN

DEFIBRILLATING WITH PADDLES OR GEL PADS

1. Defibrillate the manikin by placing paddles or gel pads on the round, metal defibrillation sites on the manikin's chest. (See *figure 4.*) As with a real patient, extreme care should be taken to make complete contact with the sternum and apex defibrillation site.
2. The equipment is now ready for defibrillation practice. Follow all normal safety precautions indicated for use and training.

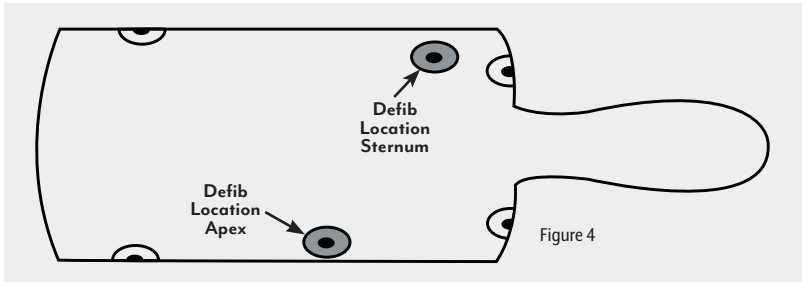

Note: In an effort to help you save money, Nasco offers sets of defibrillation training cables and chest post adapters, sold separately, to be used in place of defibrillator paddles or gel pads. Nasco does not sell defibrillators or monitors.

DEFIBRILLATING WITH SNAP-ON CABLES

Adapter posts, sold separately, are available to fit a variety of defibrillator brands' snap-on cable heads. Be sure to identify your brand of defibrillator before selecting an adapter post set. (See the Supplies and Replacement Parts section of this manual for more information.)

1. Feed the banana clip through the protective disc and screw the adapter post specific to your snap-on cable head to the banana clip. (See *figures 5 & 6.*)
2. Insert the banana clip end into the manikin's chest skin defibrillation location and snap the cable to the adapter post. (See *figures 7 & 8.*)

Note: Cables must be placed in the appropriate defibrillation location, sternum, or apex.

3. The equipment is now ready for defibrillation practice. Follow all normal safety precautions indicated for use and training.

DEFIBRILLATING WITH TRAINING CABLES

Training cables purchased from Nasco have snap-on heads assembled with the standard Training Cable Defib Adapter Post shown. Brand specific adapter posts are only needed if you are using your own snap-on defib cables with unique heads. Nasco training cables have unique plug-ins for use with your own defibrillator's specific brand. Custom training cables can be made for brands not seen below; contact Nasco for information. **IMPORTANT:** Training cables are **NOT** recommended for use with battery operated AEDs with non-rechargeable lithium batteries.

1. Insert the cable plug into your defibrillator.
2. Insert the banana clip end into the manikin defibrillation location.
3. The equipment is now ready for defibrillation practice. Follow all normal safety precautions indicated for use and training.

Note: The simulator can accept a maximum energy level of 360 joules. Nasco recommends administering the lowest possible shock in order to extend the life of your simulator.



Zoll Training Cable with Assembled Training Cable Adapter Posts (LF03961U)

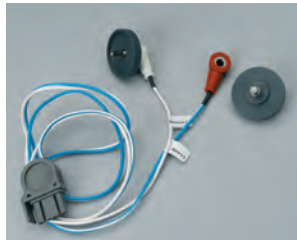

Physio Control Training Cable with Assembled Training Cable Adapter Posts (LF03962U)



Phillips Training Cables (175-0-Z13U)

CONNECTING YOUR MANIKIN TO AN ARRHYTHMIA SIMULATOR, OR LIFE/FORM® INTERACTIVE ECG SIMULATOR (LF03670U) AND DEFIB/MONITOR (SOLD SEPARATELY)



- **ON/OFF** – Press to power on and off.
- **LOW BAT** – Red indicator illuminates when battery needs replacement.
- **DEFIB DISCHG** – Green indicator illuminates for two seconds when defib discharge is sensed. **If defibrillating Nasco manikin, set defib to 2J or more. If defibrillating directly into ECG Simulator, set defib to 50J or more.**
- **convert** – Simulate cardioversion by activating convert feature. Simulator responds to defib discharge.
- **Adult Ped** – Yellow indicators tell which rhythm set is being simulated – adult or pediatric.
- **age group** – Press to select adult or pediatric rhythm set.
- **PACER PULSE** – Green indicator flashes when external pacer pulse is sensed. (Captured beat is simulated too.) Sensing occurs when external pacer current set to 60mA – 70mA or more.

1. Snap the colored ends of the four-lead cable coming from the manikin to the appropriate locations on the ECG Simulator. (See figure 9.)

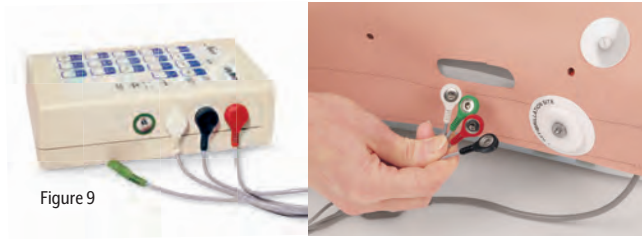

Figure 9

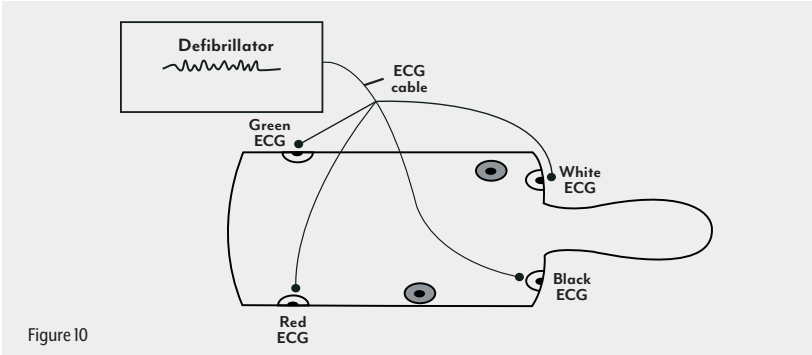

Figure 10

2. Connect your defibrillator's colored limb-lead snaps to the appropriate locations on the manikin's chest skin. (See figure 10.)
3. You should now be able to select rhythms on the ECG Simulator and view them on your monitor.
4. Change rhythm selected from waiting rhythm to running rhythm automatically using the Convert button and applying a shock to the manikin.
Note: The running rhythm indicator light is solid while the waiting rhythm blinks on and off. After the shock is applied to the manikin, the blinking rhythm indicator light turns solid and the original solid light turns off.
5. Apply paddles, gel pads, defibrillator cables with adapter posts, or training cables to the appropriate defibrillation location on the manikin. (See figure 11.)

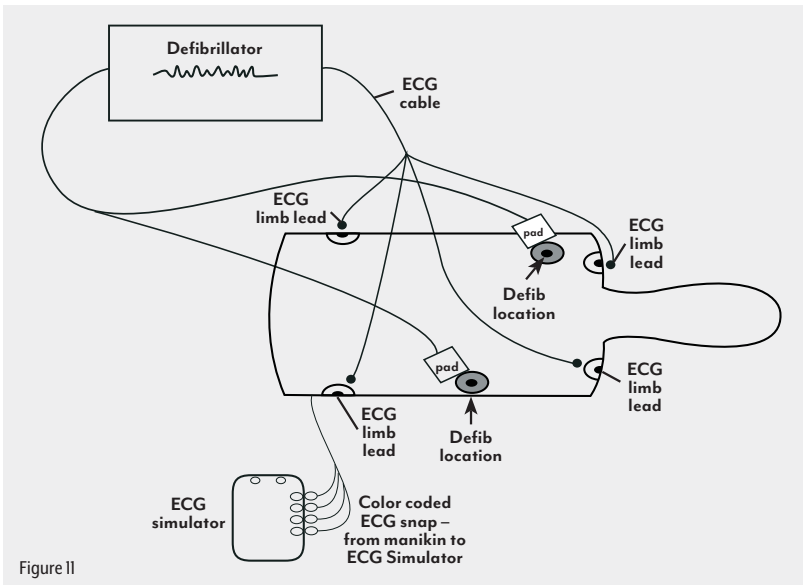

Figure 11

To change the age group, select the age group key, then the rhythm you want.

Note: At Power On the adult age group is automatically selected.

ADULT DEFIBRILLATION TRAINING

- **VF** Ventricular Fibrillation
- **VT fast** Ventricular Tachycardia. Wide QRS. Rate: 185
- **VT slow** Ventricular Tachycardia. Wide QRS. Rate: 140
- **VT poly** Ventricular Tachycardia. Fluctuating QRS axis.
- **AFIB** Atrial Fibrillation. Ventricular rate: 120-160
- **AFLTR** Atrial Flutter (2:1). Ventricular rate: 150
- **SVT** SVT alternates with NSR, then remains in SVT. SVT rate: 216
- **S TACH** Sinus Tachycardia. Rate: 120
- **NSR** Normal Sinus Rhythm. Rate: 72
- **ASYS** Asystole
- **SINUS PVC** Sinus Rhythm with PVCs. Sinus rate: 72

ADULT EXTERNAL PACER TRAINING

- **S BRDY** Sinus Bradycardia. Rate: 40
- **J BRDY** Junctional Bradycardia. Rate: 42
- **2nd I** 2nd deg. type I AV Block (4:3). Atrial rate: 60
- **2nd II PVC** 2nd deg. type II AV Block (4:3). PVCs. Wide QRS. Atrial rate: 60
- **2nd II** 2nd deg. type II AV Block (4:3). Wide QRS. Atrial rate: 60
- **3rd** 3rd deg. AV Block. Wide QRS. Ventricular rate: 37

PEDIATRIC DEFIBRILLATION TRAINING

- **VF** Ventricular Fibrillation
- **VT fast** Ventricular Tachycardia. Wide QRS. Visible P wave, Rate: 180
- **VT slow** Ventricular Tachycardia. Wide QRS. Rate: 148
- **VT poly** Ventricular Tachycardia. Fluctuating QRS axis. Short runs.
- **AFIB** Atrial Fibrillation. Small R waves. Ventricular rate: 135-160
- **AFLTR** Atrial Flutter (2:1). Ventricular rate: 150
- **SVT** Supraventricular Tachycardia. Inverted P follows QRS. rate: 216
- **S TACH** Sinus Tachycardia. Rate: 165
- **NSR** Normal Sinus Rhythm. Rate: 90
- **ASYS** Asystole
- **SINUS PVC** Sinus Rhythm with PVCs. Sinus rate: 90

PEDIATRIC EXTERNAL PACER TRAINING

- **S BRDY** Sinus Bradycardia. Rate: 50
- **J BRDY** Junctional Bradycardia. Rate: 60
- **2nd I** 2nd deg. type I AV Block (5:4). Atrial rate: 60
- **2nd II PVC** 2nd deg. type II AV Block (5:4) with PVCs. Atrial rate: 60
- **2nd II** 2nd deg. type II AV Block (5:4). Atrial rate: 60
- **3rd** 3rd deg. AV Block. Ventricular rate: 60

ACCESSORIES

LF03656U Physio Control Training Pad Adapters and Patient Simulator Adapters for LifePak 10 and LifePak 20

LF03657U Marquette Electronics Training Pad Adapters and Patient Simulator Adapters

LF03658U Space Labs/Laerdal/ Heartstart/First Medic Training Pad Adapters and Patient Simulator Adapters

LF03961U Zoll Training Cables with Adapters

LF03962U Physio Control Training Cables with Adapters for LifePak 12

Note: If you need help selecting the training pad adapters that correspond to your AED unit, please feel free to call us at 1.800.431.4310 for assistance.



Other Available *Life/form* Simulators

LF03616U Child *CRiSis*™ Manikin

LF03617U Deluxe Child *CRiSis*™ Manikin with Arrhythmia Tutor

LF03620U PALS Update Kit

LF03623U Infant Airway Management Trainer with Stand

LF03632U Child Intraosseous Infusion/Femoral Access Leg on a Stand

LF03633U Child Airway Management Trainer Torso

