

SAVE THESE INSTRUCTIONS
Yes, you can.

NOTE: Check ALL parts for shipping damage. If shipping damage is noted, DO NOT use. Contact carrier/dealer for further instruction.

⚠ WARNING

- **DO NOT** use this product or any available optional equipment without first completely reading and understanding these instructions and any additional instructional material such as owner's manuals, service manuals or instruction sheets supplied with this product or optional equipment. If you are unable to understand the warnings, cautions or instructions, contact a healthcare professional, dealer or technical personnel before attempting to use this equipment - otherwise, injury or damage may occur.
- You should **ALWAYS** consult with your physician or therapist to determine proper adjustment and usage.
- **ALWAYS** use caution when using the walker, especially on wet or icy surfaces.
- If the walker is exposed to extreme temperature (above 100°F or below 32°F), high humidity and/or becomes wet, prior to use, ensure handgrips **DO NOT** twist on side frame otherwise damage or injury may occur. The handgrips **MUST** be tight.
- Ensure that the rubber tips and/or plastic glide tips are not ripped, worn or missing. Replace the tips as necessary before using walker. **DO NOT** use rubber tips on rear leg extensions when using wheels on the front legs.
- All leg extensions **MUST** be adjusted to the same height so the walker is level. When using wheeled attachments on the front legs, the rear leg extensions **MUST** be adjusted to make the side frames level.
- Rear extension legs with rubber tips or plastic glide tips **MUST** be in contact with floor surface at all times. If an even height cannot be achieved, adjust the leg extensions so that the rear of the walker is no more than one inch lower than the front.
- Glide tips are used on rear leg extensions **ONLY** to allow walker to roll easily over indoor carpeted areas without lifting the walker off the ground. Glide tips are not recommended for use on rough surfaces (concrete, gravel, etc).
- Glide tips on rear leg extensions should only be used with front wheel attachments. **DO NOT** use glide tips on all four leg extensions at once. **DO NOT** use glide tips and rubber tips at the same time.
- When using glide tips on walker, short steps should be take. Make sure that the patient's weight is distributed evenly and directly over the walker legs. These precautions will prevent uncontrollable movement of walker.
- **ALWAYS** observe the weight limit on the labeling of your walker. The walker is not intended to support the full weight of the user. Check that all labels are present and legible. Replace if necessary.
- After unfolding or assembling walker, make sure the walker is securely locked in the **OPEN** position and level to the ground before using.
- **DO NOT** hang anything other than the manufacturer's recommended accessories on the front of the walker. This may depress the release mechanisms and prevent walker from locking into place when fully opened. **DO NOT** use a walker if the locking mechanisms do not function properly.
- **DO NOT** hang anything on either the left or right side frames (area that includes dual-release paddles) or the left and right slide tubes (area that includes palm release button). This will cause side frames or slide tubes to bend and prevent the walker from locking when fully opened. This may also cause walker to tip, resulting in injury or damage.
- Wheeled Accessories are only to be used on the front walker legs with the exception of Model Nos. 6264 - 10-inch Rear Wheel Brakes and 6265 - 13-inch Rear Wheel Brakes.
- **ALWAYS** test to see that the walker and attachments are properly and securely locked in place before using.

⚠ ACCESSORIES WARNING

- Invacare products are specifically designed and manufactured for use in conjunction with Invacare accessories. Accessories designed by other manufacturers have not been tested by Invacare and are not recommended for use with Invacare products.

Patient Height Specifications

NOTE: For models not listed, refer to labeling on product.

MODEL	PATIENT HEIGHT MIN. / MAX
6281-A, 6291-A, 6291-3F	5'3" - 6'4"
6281-JR, 6291-JR, 6240-JR, 6291-JR3F	4'4" - 5'7"
6240-A	5'4" - 6'6"
6291-5F, 6291-HDA	5'3" - 6'4" (WITH 13" EXTENSIONS)
6240-5F	5'4" - 6'6"
6240-JR5F	4'4" - 5'7"
6291-JR5F	4'4" - 5'6"
6441-A, 6441A-I	5'3" - 6'10"

Care and Maintenance

1. Make sure that all attaching hardware is in place and secure at all times.
2. Replace all broken, damaged or worn items **IMMEDIATELY**.
3. Make sure that the locking mechanisms function properly.
4. Lubricate with 3-in-1[®] oil as necessary or if wheels begin to squeak.

Using the Walker

Opening Walker

1. Swing the side frames outward until an audible "click" is heard.

NOTE: On some models, the palm release button on the front will pop up when the click is heard.

NOTE: On some models, the dual-release paddles will engage upward when the click is heard.

2. Test walker by grasping the side frames and, with some force, attempt to fold them inward.

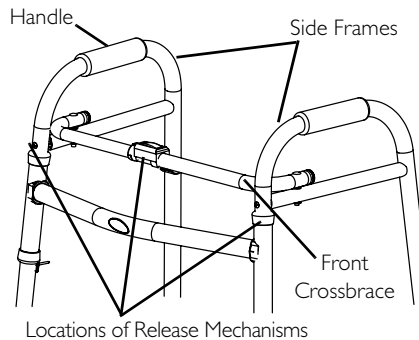

NOTE: The walker will remain locked in the open position when it is engaged properly.

Folding Walker

1. Press the release mechanism(s) and pivot the corresponding side frame inward toward the front crossbrace

NOTE: A release mechanism can either be located on the side frames, such as paddles, or on the front, such as a palm release button.

2. Repeat the same procedure for the remaining side frame.

Installing/Adjusting Leg Extensions

1. Press the snap buttons on the lower legs of the walker and insert the leg extension.
2. Press the snap button and slide the leg up or down to the proper height.

⚠ WARNING

Ensure that the snap button protrudes through the appropriate adjustment hole on the leg extension.

3. Repeat STEPS 1 and 2 for each leg extension.
4. Adjust leg extensions to ensure that the walker is level and when the user's arm is extended downward the handle is at wrist height.

NOTE: Model No. 6291-3F, 6291-3E, 6291-5F, 6291-JR3F, 6240-5F, 6291-JR5F and 6240-JR5F: Ensure that fixed wheel attachments are positioned to the outside of the walker to help maintain stability.

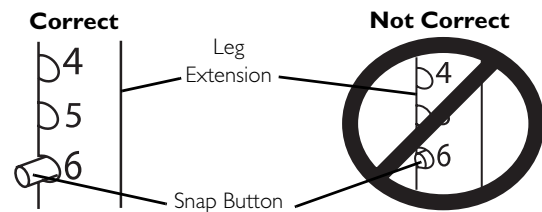

Limited Warranty

Invacare warrants this product to be free from defects in materials and workmanship.

PLEASE NOTE: THE WARRANTY BELOW HAS BEEN DRAFTED TO COMPLY WITH FEDERAL LAW APPLICABLE TO PRODUCTS MANUFACTURED AFTER JULY 4, 1975.

This warranty is extended only to the original purchaser/user of our products.

This warranty gives you specific legal rights and you may also have other legal rights which vary from state to state.

Invacare warrants all walker models to be free from defects in materials and workmanship for five years for the original purchaser. If within such warranty period any such product shall be proven to be defective, such product shall be repaired or replaced, at Invacare's option. This warranty does not include any labor or shipping charges incurred in replacement part installation or repair of any such product. Invacare's sole obligation and your exclusive remedy under this warranty shall be limited to such repair and/or replacement.

For warranty service, please contact the dealer from whom you purchased your Invacare product. In the event you do not receive satisfactory warranty service, please write directly to Invacare at the address on the back page. Provide dealer's name, address, model number, date of purchase, indicate nature of the defect and, if the product is serialized, indicate the serial number.

Invacare Corporation will use a return authorization. The defective unit or parts must be returned for warranty inspection using the serial number, when applicable, as identification within thirty days of return authorization date. **DO NOT** return products to our factory without our prior consent. C.O.D. shipments will be refused; please prepay shipping charges.

LIMITATIONS AND EXCLUSIONS: THE WARRANTY SHALL NOT APPLY TO PROBLEMS ARISING FROM NORMAL WEAR OR FAILURE TO ADHERE TO THE ENCLOSED INSTRUCTIONS. IN ADDITION, THE FOREGOING WARRANTY SHALL NOT APPLY TO SERIAL NUMBERED PRODUCTS IF THE SERIAL NUMBER HAS BEEN REMOVED OR DEFACED; PRODUCTS SUBJECT TO NEGLIGENCE, ACCIDENT, IMPROPER OPERATION, MAINTENANCE OR STORAGE; OR PRODUCTS MODIFIED WITHOUT INVACARE'S EXPRESS WRITTEN CONSENT INCLUDING, BUT NOT LIMITED TO: MODIFICATION THROUGH THE USE OF UNAUTHORIZED PARTS OR ATTACHMENTS; PRODUCTS DAMAGED BY REASON OF REPAIRS MADE TO ANY COMPONENT WITHOUT THE SPECIFIC CONSENT OF INVACARE; PRODUCTS DAMAGED BY CIRCUMSTANCES BEYOND INVACARE'S CONTROL; PRODUCTS REPAIRED BY ANYONE OTHER THAN AN INVACARE DEALER, SUCH EVALUATION SHALL BE SOLELY DETERMINED BY INVACARE.

THE FOREGOING EXPRESS WARRANTY IS EXCLUSIVE AND IN LIEU OF ANY OTHER EXPRESS WARRANTIES WHATSOEVER, WHETHER EXPRESS OR IMPLIED, INCLUDING THE IMPLIED WARRANTIES OF MERCHANTABILITY AND FITNESS FOR A PARTICULAR PURPOSE AND THE SOLE REMEDY FOR VIOLATIONS OF ANY WARRANTY WHATSOEVER, SHALL BE LIMITED TO REPAIR OR REPLACEMENT OF THE DEFECTIVE PRODUCT PURSUANT TO THE TERMS CONTAINED HEREIN. THE APPLICATION OF ANY IMPLIED WARRANTY WHATSOEVER SHALL NOT EXTEND BEYOND THE DURATION OF THE EXPRESS WARRANTY PROVIDED HEREIN. INVACARE SHALL NOT BE LIABLE FOR ANY CONSEQUENTIAL OR INCIDENTAL DAMAGES WHATSOEVER.

THIS WARRANTY SHALL BE EXTENDED TO COMPLY WITH STATE/PROVINCIAL LAWS AND REQUIREMENTS.