

SAVE THESE INSTRUCTIONS

Yes, you can.®

NOTE: Check ALL parts for shipping damage. If shipping damage is noted, DO NOT use. Contact carrier/dealer for further instruction.

⚠ WARNING

- **DO NOT** install or use this equipment without first reading and understanding these instructions. If you are unable to understand the Warnings, Cautions or Instructions, contact a healthcare professional, dealer or technical personnel before attempting to install this equipment - otherwise, injury or damage may occur.
- Each individual should always consult with their physician or therapist to determine proper adjustment and usage.
- Invacare products are specifically designed and manufactured for use in conjunction with Invacare accessories. Accessories designed by other manufacturers have not been tested by Invacare and are not recommended for use with Invacare products.
- Proper height adjustments must be made to both the leg extension and the crutch handle. A dealer or therapist should aid in the proper placement for maximum balance and support.
- Be sure that snap buttons are fully protruding through the same respective adjustment hole of each leg extension. This ensures that the adjustable legs are securely locked into position and an even height adjustment is obtained.
- Wing nuts **MUST** be tight at all times.
- Ensure that rubber crutch tips are not ripped, worn or missing. Replace before using the crutches.
- **ALWAYS** observe the weight limit on the labeling of this product. Check that all labels are present and legible. Replace if necessary.

Patient Height Specification

NOTE: For models not listed, please check labeling on product.

MODEL	PATIENT HEIGHT MIN./MAX
8115-J, 8120-J, 8130-J	4'6" - 5'2"
8115-A, 8120-A, 8130 -A	5'2" - 5'10"

MODEL	PATIENT HEIGHT MIN./MAX
8115-T, 8120-T, 8130-T	5'10" - 6'6"

Adjusting Handle Position

1. Do one of the following:
 - Remove the wing nut and bolt securing the handle to the crutch (Detail "A").
 - Push both handle locks IN (direction of arrow stamped on side of handle lock) (Detail "B").
2. Align the handle with the desired set of adjustment holes.

NOTE: Quick Adjust Crutch - There will be an audible click when handle locks are fully engaged and secure.

3. If necessary, secure with wing nut and bolt.
4. Repeat for other crutch.

Adjust the Leg Extension

Depress both snap buttons on the leg extension and allow them to snap through the desired adjustment holes on the crutch leg frame. Repeat for other crutch (Detail "C").

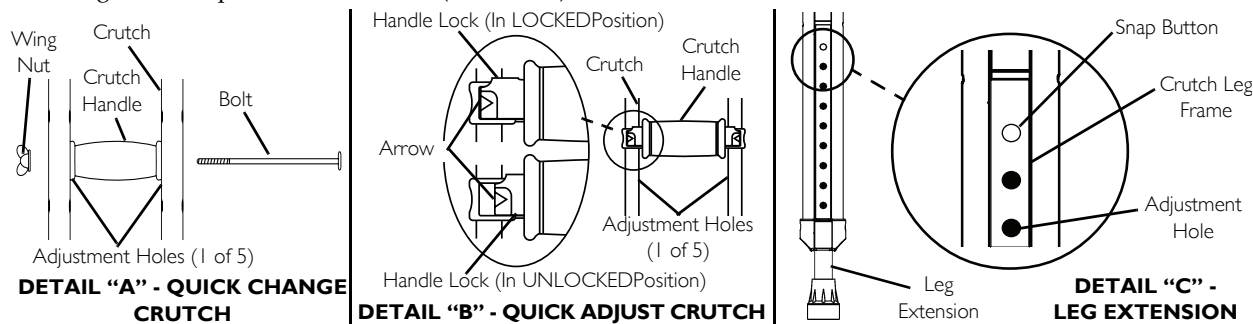

Limited Warranty

PLEASE NOTE: THE WARRANTY BELOW HAS BEEN DRAFTED TO COMPLY WITH FEDERAL LAW APPLICABLE TO PRODUCTS MANUFACTURED AFTER JULY 4, 1975.

This warranty is extended only to the original purchaser/user of our products.

This warranty gives you specific legal rights and you may also have other legal rights which vary from state to state.

Invacare warrants its product to be free from defects in material and workmanship for 3 years of use by original purchaser. If within such warranty period any such product shall be proven to be defective, such product shall be repaired or replaced, at Invacare's option. This warranty does not include any labor or shipping charges incurred in replacement part installation or repair of any such product. Invacare's sole obligation and your exclusive remedy under this warranty shall be limited to such repair and/or replacement.

For warranty service, please contact the dealer from whom you purchased your Invacare product. In the event you do not receive satisfactory warranty service, please write directly to Invacare at the address on the back page. Provide dealer's name, address, model number, date of purchase, indicate nature of the defect and, if the product is serialized, indicate the serial number.

Invacare Corporation will use a return authorization. The defective unit or parts must be returned for warranty inspection using the serial number, when applicable, as identification within thirty (30) days of return authorization date. **DO NOT** return products to our factory without our prior consent. C.O.D. shipments will be refused; please prepay shipping charges.

LIMITATIONS AND EXCLUSIONS: THE WARRANTY SHALL NOT APPLY TO PROBLEMS ARISING FROM NORMAL WEAR OR FAILURE TO ADHERE TO THE ENCLOSED INSTRUCTIONS. IN ADDITION, THE FOREGOING WARRANTY SHALL NOT APPLY TO SERIAL NUMBERED PRODUCTS IF THE SERIAL NUMBER HAS BEEN REMOVED OR DEFACED; PRODUCTS SUBJECT TO NEGLIGENCE, ACCIDENT, IMPROPER OPERATION, MAINTENANCE OR STORAGE; OR PRODUCTS MODIFIED WITHOUT INVACARE'S EXPRESS WRITTEN CONSENT (INCLUDING, BUT NOT LIMITED TO MODIFICATION THROUGH THE USE OF UNAUTHORIZED PARTS OR ATTACHMENTS, PRODUCTS DAMAGED BY REASON OF REPAIRS MADE TO ANY COMPONENT WITHOUT THE SPECIFIC CONSENT OF INVACARE; PRODUCTS DAMAGED BY CIRCUMSTANCES BEYOND INVACARE'S CONTROL; PRODUCTS REPAIRED BY ANYONE OTHER THAN AN AUTHORIZED INVACARE DEALER). SUCH EVALUATION SHALL BE SOLELY DETERMINED BY INVACARE. THE FOREGOING EXPRESS WARRANTY IS EXCLUSIVE AND IN LIEU OF ANY OTHER WARRANTIES WHATSOEVER, WHETHER EXPRESS OR IMPLIED, INCLUDING THE IMPLIED WARRANTIES OF MERCHANTABILITY AND FITNESS FOR A PARTICULAR PURPOSE, AND THE SOLE REMEDY FOR VIOLATIONS OF ANY WARRANTY WHATSOEVER, SHALL BE LIMITED TO REPAIR OR REPLACEMENT OF THE DEFECTIVE PRODUCT PURSUANT TO THE TERMS CONTAINED HEREIN. THE APPLICATION OF ANY IMPLIED WARRANTY WHATSOEVER SHALL NOT EXTEND BEYOND THE DURATION OF THE EXPRESS WARRANTY PROVIDED HEREIN. INVACARE SHALL NOT BE LIABLE FOR ANY CONSEQUENTIAL OR INCIDENTAL DAMAGES WHATSOEVER. THIS WARRANTY SHALL BE EXTENDED TO COMPLY WITH STATE/PROVINCIAL LAWS AND REQUIREMENTS.